

RLL^{PLUS}

Stage Programming

In This Chapter. . . .

- Introduction to Stage Programming
 - Learning to Draw State Transition Diagrams
 - Using the Stage Jump Instruction for State Transitions
 - Stage Program Example: Toggle On/Off Lamp Controller
 - Four Steps to Writing a Stage Program
 - Stage Program Example: A Garage Door Opener
 - Stage Program Design Considerations
 - RLL^{PLUS} Stage Instructions
 - Questions and Answers about Stage Programs
-

Introduction to Stage Programming

Stage Programming provides a way to organize and program complex applications with relative ease, when compared to purely relay ladder logic (RLL) solutions. Stage programming does not replace or negate the use of traditional boolean ladder programming. This is why Stage Programming is also called RLL^{PLUS}. You won't have to discard any training or experience you already have. Stage programming simply allows you to divide and organize a RLL program into groups of ladder instructions called stages. This allows quicker and more intuitive ladder program development than traditional RLL alone provides.

Overcoming "Stage Fright"

Many PLC programmers in the industry have become comfortable using RLL for every PLC program they write... but often remain skeptical or even fearful of learning new techniques such as stage programming. While RLL is great at solving boolean logic relationships, it has disadvantages as well:

- Large programs can become almost unmanageable, because of a lack of structure.
- In RLL, latches must be tediously created from self-latching relays.
- When a process gets stuck, it is difficult to find the rung where the error occurred.
- Programs become difficult to modify later, because they do not intuitively resemble the application problem they are solving.

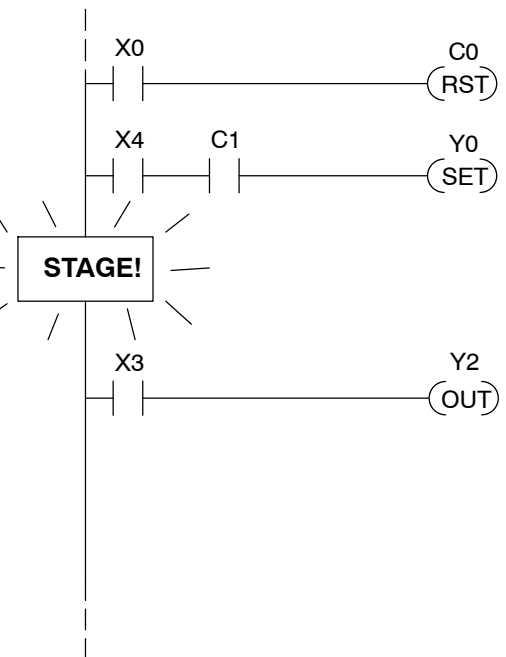

It's easy to see that these inefficiencies consume a lot of additional time, and time is money. *Stage programming overcomes these obstacles!* We believe a few moments of studying the stage concept is one of the greatest investments in programming speed and efficiency a PLC programmer can make!

So, we encourage you to study stage programming and add it to your "toolbox" of programming techniques. This chapter is designed as a self-paced tutorial on stage programming. For best results:

- Start at the beginning and do not skip over any sections.
- Study each stage programming concept by working through each example. The examples build progressively on each other.
- Read the stage Questions and Answers at the end of the chapter for a quick review.

Learning to Draw State Transition Diagrams

Introduction to Process States

Those familiar with ladder program execution know that the CPU must scan the ladder program repeatedly, over and over. Its three basic steps are:

1. Read the inputs
2. Execute the ladder program
3. Write the outputs

The benefit is that a change at the inputs can affect the outputs in just a few milliseconds.



PLC Scan

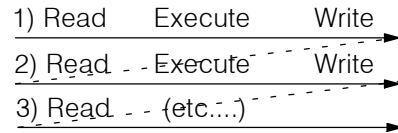

Most manufacturing processes consist of a series of activities or conditions, each lasting for several seconds, minutes, or even hours. We might call these “process states”, which are either active or inactive at any particular time. A challenge for RLL programs is that a particular input event may last for just a brief instant. We typically create latching relays in RLL to preserve the input event in order to maintain a process state for the required duration.

We can organize and divide ladder logic into sections called “stages”, representing process states. But before we describe stages in detail, we will reveal **the secret to understanding stage programming**: state transition diagrams.

The Need for State Diagrams

Sometimes we need to forget about the scan nature of PLCs, and focus our thinking toward the states of the process we need to identify. Clear thinking and concise analysis of an application gives us the best chance at writing efficient, bug-free programs. *State diagrams are just a tool to help us draw a picture of our process!* You’ll discover that if we can get the picture right, **our program will also be right!**

A 2-State Process

Consider the simple process shown to the right, which controls an industrial motor. We will use a green momentary SPST pushbutton to turn the motor on, and a red one to turn it off. The machine operator will press the appropriate pushbutton for just a second or so. The two states of our process are ON and OFF.

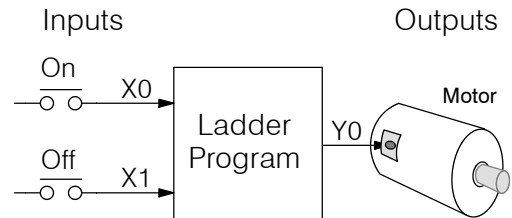

The next step is to draw a *state transition diagram*, as shown to the right. It shows the two states OFF and ON, with two transition lines in-between. When the event X0 is true, we transition from OFF to ON. When X1 is true, we transition from ON to OFF.

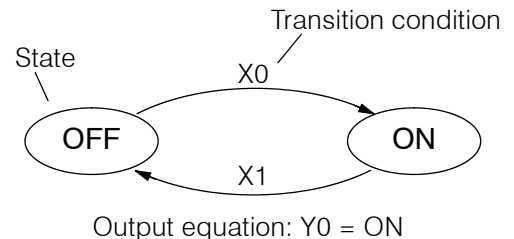

If you’re following along, you are very close to grasping the concept and the problem-solving power of state transition diagrams. The output of our controller is Y0, which is true any time we are in the ON state. In a boolean sense, $Y0 = ON$ state. Next, we will implement the state diagram first as RLL, then as a stage program. This will help you see the relationship between the two methods in problem solving.

The state transition diagram to the right is a picture of the solution we need to create. The beauty of it is this: it expresses the problem independently of the programming language we may use to realize it. In other words, *by drawing the diagram we have already solved the control problem!*

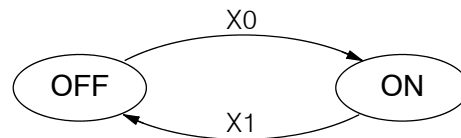

Output equation: $Y0 = ON$

First, we'll translate the state diagram to traditional RLL. Then we'll show how easy it is to translate the diagram into a stage programming solution.

RLL Equivalent

The RLL solution is shown to the right. It consists of a self-latching control relay, C0. When the On pushbutton (X0) is pressed, output coil C0 turns on and the C0 contact on the second row latches itself on. So, X0 **sets the latch** C0 on, and it remains on after the X0 contact opens. The motor output Y0 also has power flow, so the motor is now on.

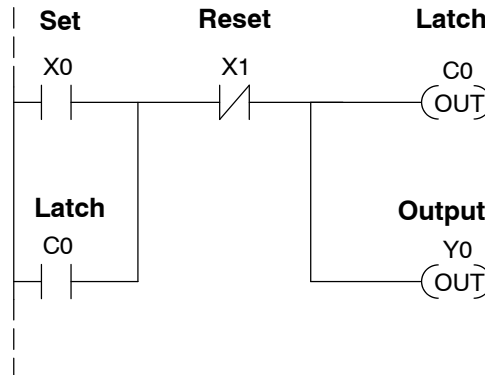

When the Off pushbutton (X1) is pressed, it opens the normally-closed X1 contact, which **resets the latch**. Motor output Y0 turns off when the latch coil C0 goes off.

Stage Equivalent

The stage program solution is shown to the right. The two inline stage boxes S0 and S1 correspond to the two states OFF and ON. The ladder rung(s) below each stage box belong to each respective stage. This means that the PLC only has to scan those rungs when the corresponding stage is active!

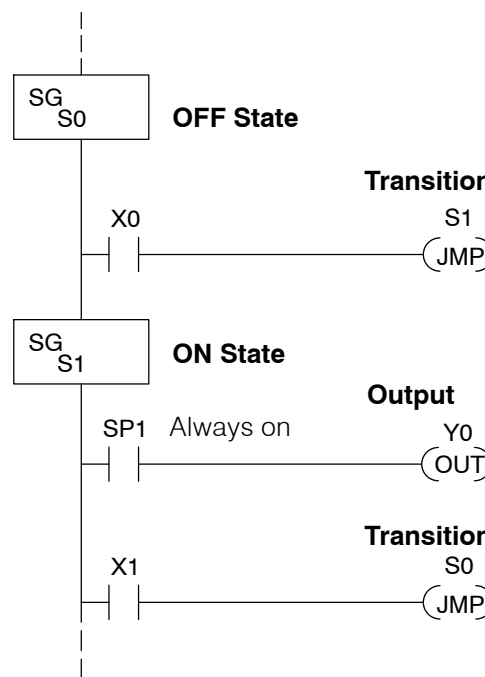

For now, let's assume we begin in the OFF State, so stage S0 is active. When the On pushbutton (X0) is pressed, a stage transition occurs. The JMP S1 instruction executes, which simply turns off the stage bit S0 and turns on stage bit S1. So on the next PLC scan, the CPU will not execute stage S0, but will execute stage S1!

In the On State (stage S1), we want the motor to always be on. The special relay contact SP1 is defined as always on, so Y0 turns the motor on.

When the Off pushbutton (X1) is pressed, a transition back to the Off State occurs. The JMP S0 instruction executes, which simply turns off the stage bit S1 and turns on stage bit S0. On the next PLC scan, the CPU will not execute stage S1, so the motor output Y0 will turn off. The Off state (stage 0) will be ready for the next cycle.

Let's Compare

Right now, you may be thinking "I don't see the big advantage to Stage Programming... in fact, the stage program is longer than the plain RLL program". Well, now is the time to exercise a bit of faith. As control problems grow in complexity, stage programming quickly out-performs RLL in simplicity, program size, etc.

For example, consider the diagram below. Notice how easy it is to correlate the OFF and ON states of the state transition diagram below to the stage program at the right. Now, we challenge anyone to easily identify the same states in the RLL program on the previous page!

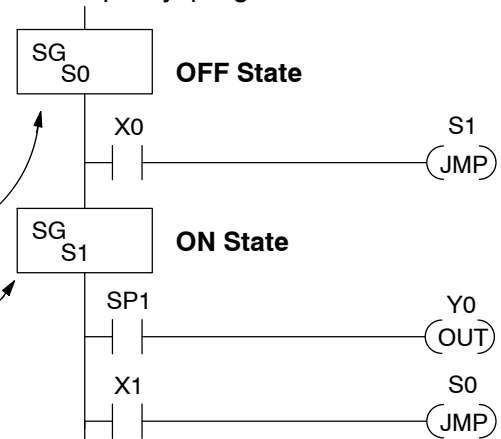
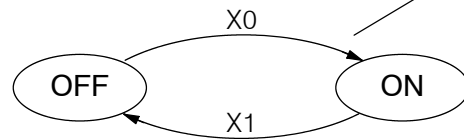

Initial Stages

At powerup and Program-to-Run Mode transitions, the PLC always begins with all normal stages (SG) off. So, the stage programs shown so far have actually had no way to get started (because rungs are not scanned unless their stage is active).

Assume that we want to always begin in the Off state (motor off), which is how the RLL program works. The Initial Stage (ISG) is defined to be active at powerup. In the modified program to the right, we have changed stage S0 to the ISG type. This ensures the PLC will scan contact X0 after powerup, because Stage S0 is active. **After powerup, an Initial Stage (ISG) works just like any other stage!**

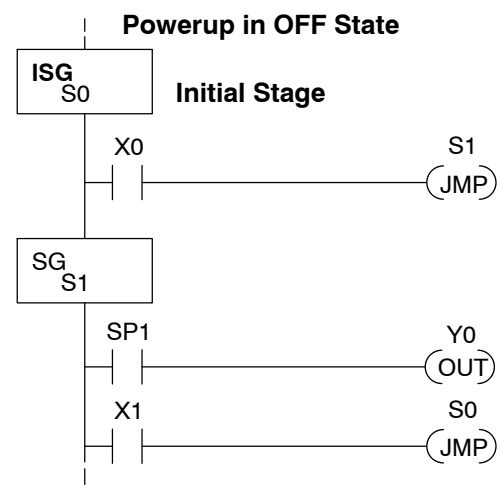

We can change both programs so that the motor is ON at powerup. In the RLL below, we must add a first scan relay SP0, latching C0 on. In the stage example to the right, we simply make Stage S1 an initial stage (ISG) instead of S0.

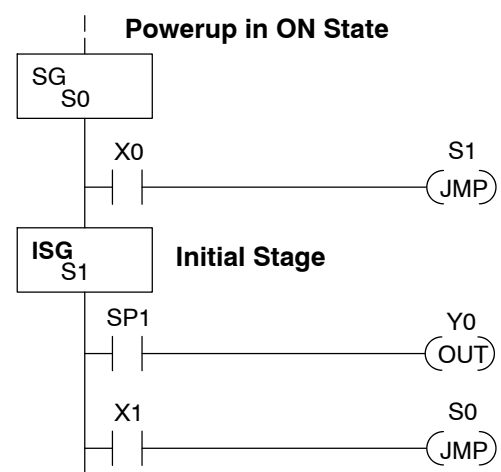
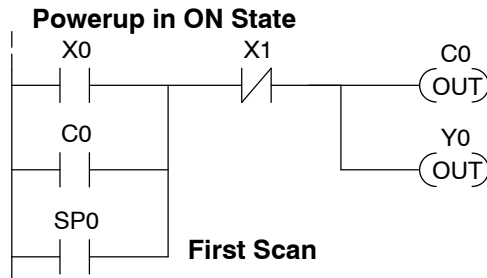

NOTE: If the ISG is within the retentive range for stages, the ISG will remain in the state it was in before power down and will NOT turn itself on during the first scan.



We can mark our desired powerup state as shown to the right, which helps us remember to use the appropriate Initial Stages when creating a stage program. It is permissible to have as many initial stages as the process requires.

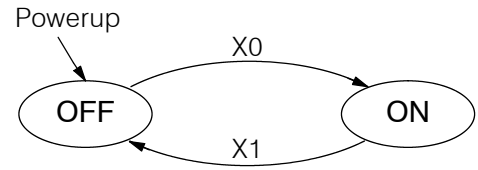

What Stage Bits Do You may recall that a stage is just a section of ladder program which is either active or inactive at a given moment. All stage bits (S0 to S77) reside in the PLC's image register as individual status bits. Each stage bit is either a boolean 0 or 1 at any time. Program execution always reads ladder rungs from top to bottom, and from left to right. The drawing below shows the effect of stage bit status. The ladder rungs below the stage instruction continuing until the next stage instruction or the end of program belong to stage 0. Its equivalent operation is shown on the right. When S0 is true, the two rungs have power flow.

- If Stage bit S0 = 0, its ladder rungs *are not* scanned (executed).
- If stage bit S0 = 1, its ladder rungs *are* scanned (executed).

Actual Program Appearance

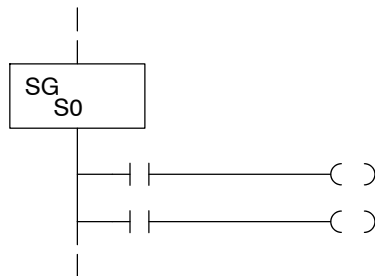

Functionally Equivalent Ladder

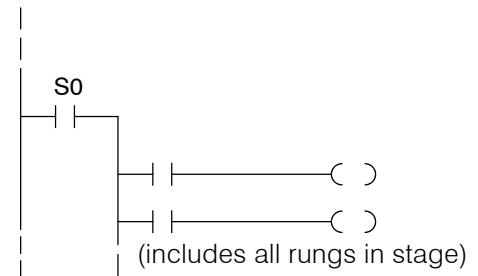

Stage Instruction Characteristics

The inline stage boxes on the left power rail divide the ladder program rungs into stages. Some stage rules are:

- **Execution** - Only logic in active stages are executed on any scan.
- **Transitions** - Stage transition instructions take effect on the next occurrence of the stages involved.
- **Octal numbering** - Stages are numbered in octal, like I/O points, etc. So "S8" is not valid.
- **Total Stages** - The DL105 offers up to 256 stages (S0 to S377 in octal).
- **No duplicates** - Each stage number is unique and can be used just once.
- **Any order** - You can skip numbers and sequence the stage numbers in any order.
- **Last Stage** - the last stage in the ladder program includes all rungs from its stage box until the end coil.

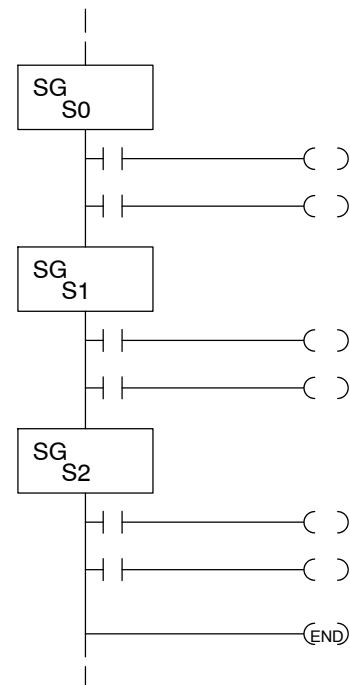

Using the Stage Jump Instruction for State Transitions

Stage Jump, Set, and Reset Instructions

The stage JMP instruction we have used deactivates the stage in which the instruction occurs, while activating the stage in the JMP instruction. Refer to the state transition shown below. When contact X0 energizes, the state transition from S0 to S1 occurs. The two stage examples shown below are equivalent. So, the stage Jump instruction is equal to a Stage Reset of the current stage, plus a Stage Set instruction for the stage to which we want to transition.

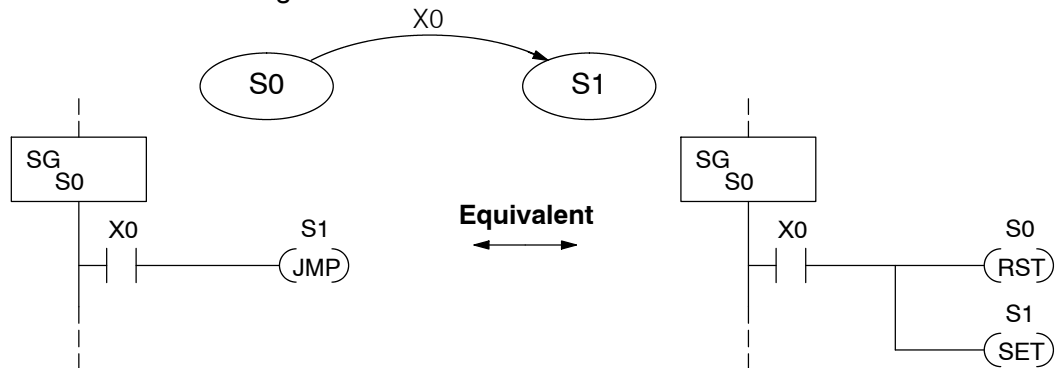

Please Read Carefully - The jump instruction is easily misunderstood. The “jump” does not occur immediately like a GOTO or GOSUB program control instruction when executed. Here’s how it works:

- The jump instruction resets the stage bit of the stage in which it occurs. All rungs in the stage still finish executing during the current scan, *even if there are other rungs in the stage below the jump instruction!*
- The reset will be in effect on the following scan, so the stage that executed the jump instruction previously will be inactive and bypassed.
- The stage bit of the stage named in the Jump instruction will be set immediately, so the stage will be executed on its next occurrence. In the left program shown below, stage S1 executes during the *same scan* as the JMP S1 occurs in S0. In the example on the right, Stage S1 executes on the *next scan* after the JMP S1 executes, because stage S1 is located *above* stage S0.

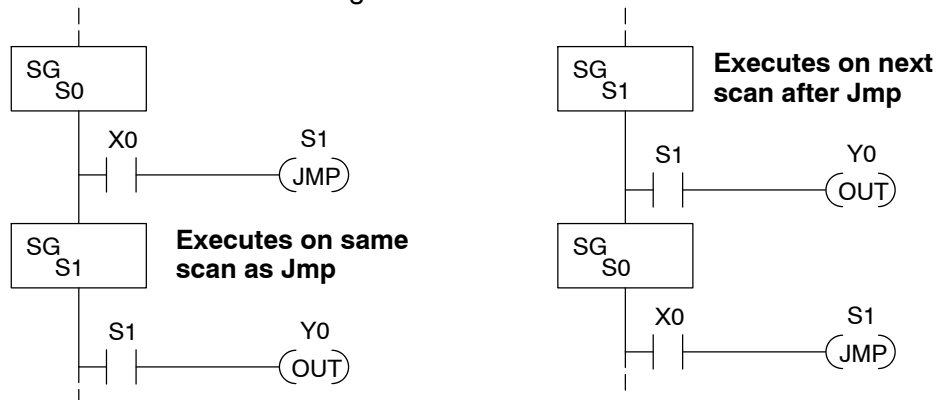

NOTE: Assume we start with Stage 0 active and Stage 1 inactive for both examples.



Stage Program Example: Toggle On/Off Lamp Controller

A 4-State Process In the process shown to the right, we use an ordinary momentary pushbutton to control a light bulb. The ladder program will latch the switch input, so that we will push and release to turn on the light, push and release again to turn it off (sometimes called toggle function). Sure, we could just buy a mechanical switch with the alternate on/off action built in... However, this example is educational and also fun!

Next we draw the state transition diagram. A typical first approach is to use X0 for both transitions (like the example shown to the right). However, *this is incorrect* (please keep reading).

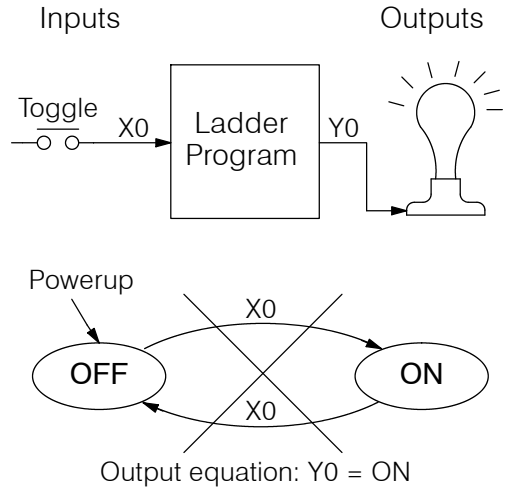

Note that this example differs from the motor example, because now we have just one pushbutton. When we press the pushbutton, both transition conditions are met. We would just transition around the state diagram at top speed. If implemented in stage, this solution would flash the light on or off each scan (obviously undesirable)!

The solution is to make the the push and the release of the pushbutton separate events. Refer to the new state transition diagram below. At powerup we enter the OFF state. When switch X0 is pressed, we enter the Press-ON state. When it is released, we enter the ON state. Note that X0 with the bar above it denotes X0 NOT.

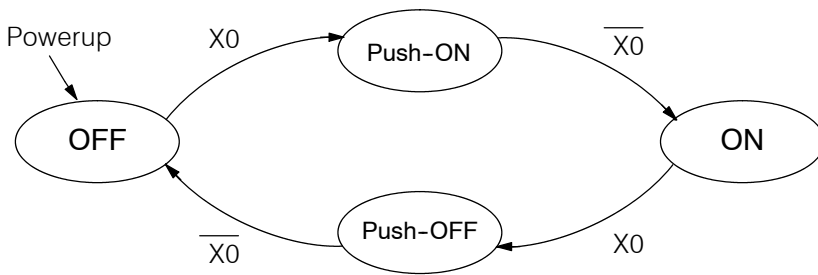

Output equation: Y0 = ON

When in the ON state, another push and release cycle similarly takes us back to the OFF state. Now we have two unique states (OFF and ON) used when the pushbutton is released, which is what was required to solve the control problem.

The equivalent stage program is shown to the right. The desired powerup state is OFF, so we make S0 an initial stage (ISG). In the ON state, we add special relay contact SP1, which is always on.

Note that even as our programs grow more complex, it is still easy to correlate the state transition diagram with the stage program!

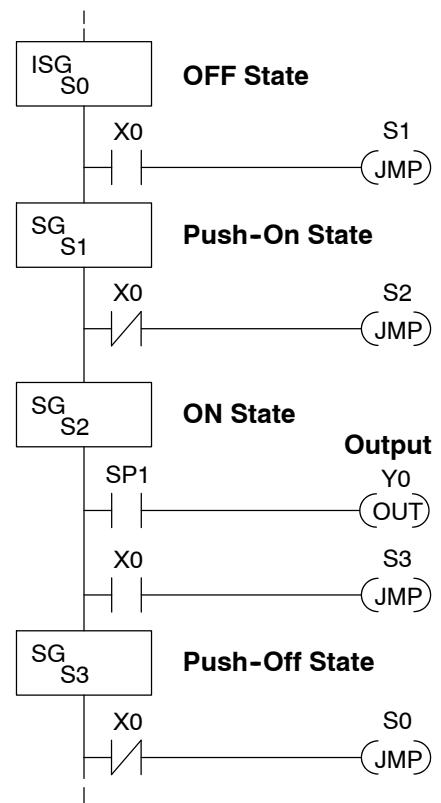

RLL PLUS Stage Programming

Four Steps to Writing a Stage Program

By now, you've probably noticed that we follow the same steps to solve each example problem. The steps will probably come to you automatically if you work through all the examples in this chapter. It's helpful to have a checklist to guide us through the problem solving. The following steps summarize the stage program design procedure:

1. Write a Word Description of the application.

Describe all functions of the process in your own words. Start by listing what happens first, then next, etc. If you find there are too many things happening at once, try dividing the problem into more than one process. Remember, you can still have the processes communicate with each other to coordinate their overall activity.

2. Draw the Block Diagram.

Inputs represent all the information the process needs for decisions, and outputs connect to all devices controlled by the process.

- Make lists of inputs and outputs for the process.
- Assign I/O point numbers (X and Y) to physical inputs and outputs.

3. Draw the State Transition Diagram.

The state transition diagram describes the central function of the block diagram, reading inputs and generating outputs.

- Identify and name the states of the process.
- Identify the event(s) required for each transition between states.
- Ensure the process has a way to re-start itself, or is cyclical.
- Choose the powerup state for your process.
- Write the output equations.

4. Write the Stage Program.

Translate the state transition diagram into a stage program.

- Make each state a stage. Remember to number stages in octal. Up to 256 total stages are available in the DL105, numbered 0 to 377 in octal.
- Put transition logic inside the stage which originates each transition (the stage each arrow points away from).
- Use an initial stage (ISG) for any states that must be active at powerup.
- Place the outputs or actions in the appropriate stages.

You'll notice that Steps 1 through 3 just *prepare* us to write the stage program in Step 4. However, the program virtually writes itself because of the preparation beforehand. Soon you'll be able to start with a word description of an application and create a stage program in one easy session!

Stage Program Example: A Garage Door Opener

Garage Door Opener Example

In this next stage programming example we'll create a garage door opener controller. Hopefully most readers are familiar with this application, and we can have fun besides!

The first step we must take is to describe how the door opener works. We will start by achieving the basic operation, waiting to add extra features later. Stage programs are very easy to modify.

Our garage door controller has a motor which raises or lowers the door on command. The garage owner pushes and releases a momentary pushbutton once to raise the door. After the door is up, another push-release cycle will lower the door.

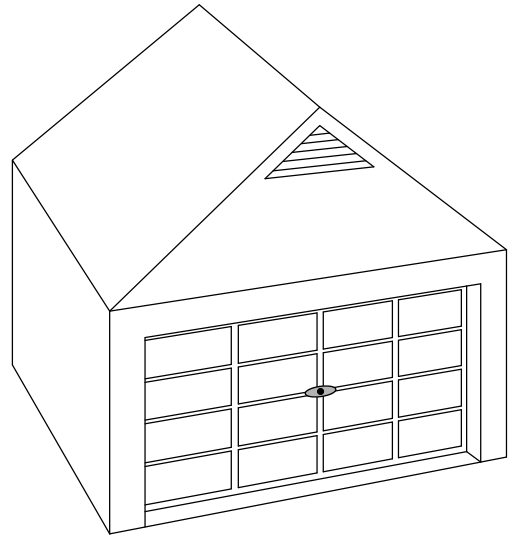

In order to identify the inputs and outputs of the system, it's sometimes helpful to sketch its main components, as shown in the door side view to the right. The door has an up limit and a down limit switch. Each limit switch closes only when the door has reach the end of travel in the corresponding direction. In the middle of travel, neither limit switch is closed.

The motor has two command inputs: raise and lower. When neither input is active, the motor is stopped.

The door command is just a simple pushbutton. Whether wall-mounted as shown, or a radio-remote control, all door control commands logical OR together as one pair of switch contacts.

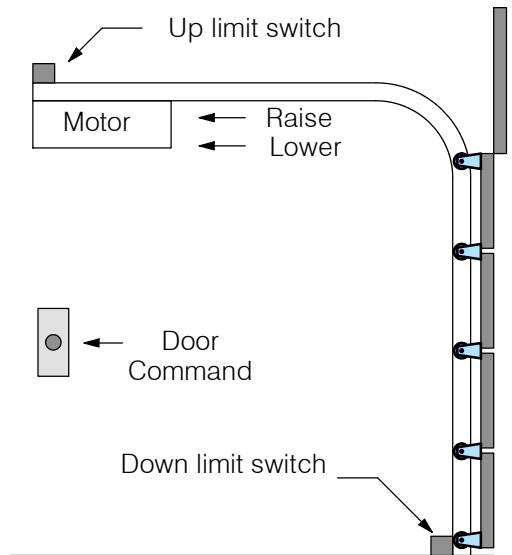

Draw the Block Diagram

The block diagram of the controller is shown to the right. Input X0 is from the pushbutton door control. Input X1 energizes when the door reaches the full up position. Input X2 energizes when the door reaches the full down position. When the door is positioned between fully up or down, both limit switches are open.

The controller has two outputs to drive the motor. Y1 is the up (raise the door) command, and Y2 is the down (lower the door) command.

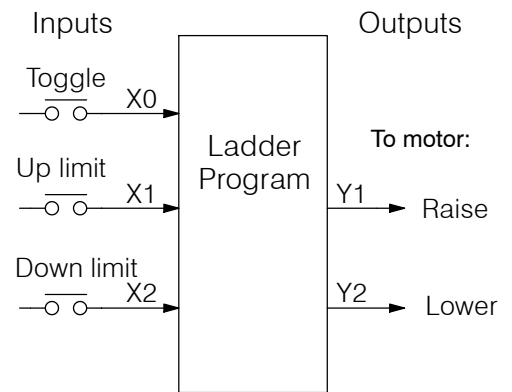

Draw the State Diagram

Now we are ready to draw the state transition diagram. Like the previous light bulb controller example, this application also has just one switch for the command input. Refer to the figure below.

- When the door is down (DOWN state), nothing happens until X0 energizes. Its push and release brings us to the RAISE state, where output Y1 turns on and causes the motor to raise the door.
- We transition to the UP state when the up limit switch (X1) energizes, and turns off the motor.
- Then nothing happens until another X0 press-release cycle occurs. That takes us to the LOWER state, turning on output Y2 to command the motor to lower the door. We transition back to the DOWN state when the down limit switch (X2) energizes.

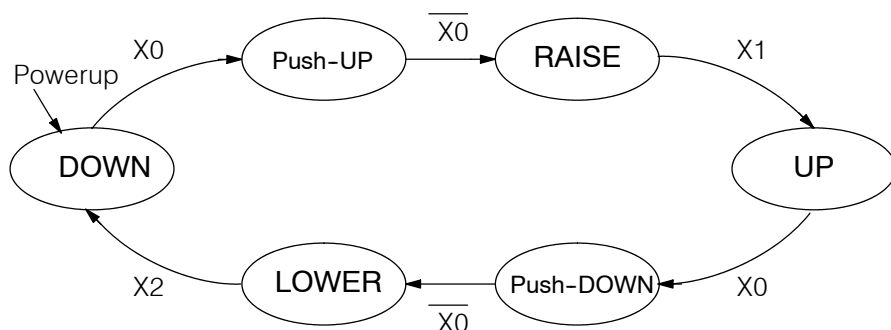

Output equations: Y1 = RAISE Y2 = LOWER

The equivalent stage program is shown to the right. For now, we will assume the door is down at powerup, so the desired powerup state is DOWN. We make S0 an initial stage (ISG). Stage S0 remains active until the door control pushbutton activates. Then we transition (JMP) to Push-UP stage, S1.

A push-release cycle of the pushbutton takes us through stage S1 to the RAISE stage, S2. We use the always-on contact SP1 to energize the motor's raise command, Y1. When the door reaches the fully-raised position, the up limit switch X1 activates. This takes us to the UP Stage S3, where we wait until another door control command occurs.

In the UP Stage S3, a push-release cycle of the pushbutton will take us to the LOWER Stage S5, where we activate Y2 to command the motor to lower the door. This continues until the door reaches the down limit switch, X2. When X2 closes, we transition from Stage S5 to the DOWN stage S0, where we began.

NOTE: The only special thing about an initial stage (ISG) is that it is automatically active at powerup. Afterwards, it is just like any other.

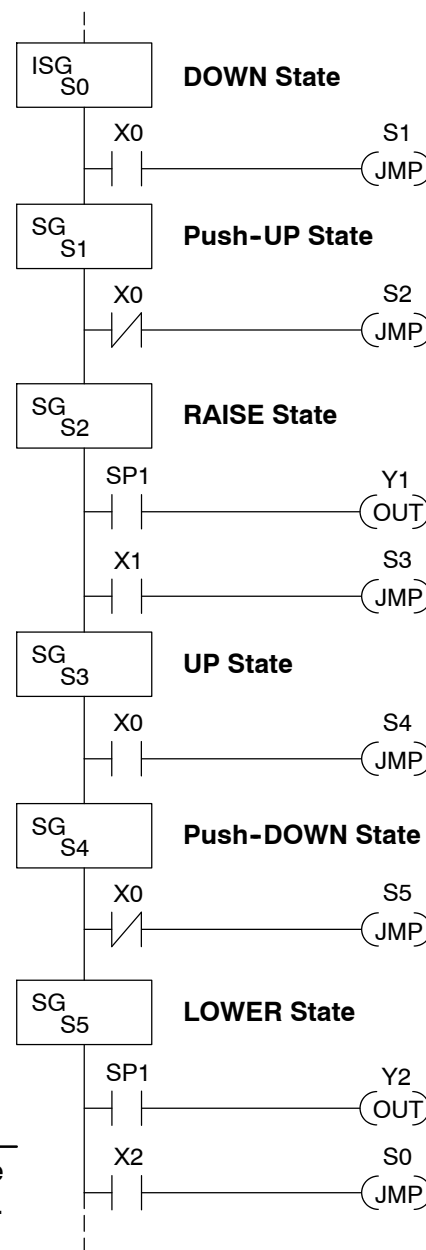

Add Safety Light Feature

Next we will add a safety light feature to the door opener system. It's best to get the main function working first as we have done, then adding the secondary features.

The safety light is standard on many commercially-available garage door openers. It is shown to the right, mounted on the motor housing. The light turns on upon any door activity, remaining on for approximately 3 minutes afterwards.

This part of the exercise will demonstrate the use of parallel states in our state diagram. Instead of using the JMP instruction, we'll use the set and reset commands.

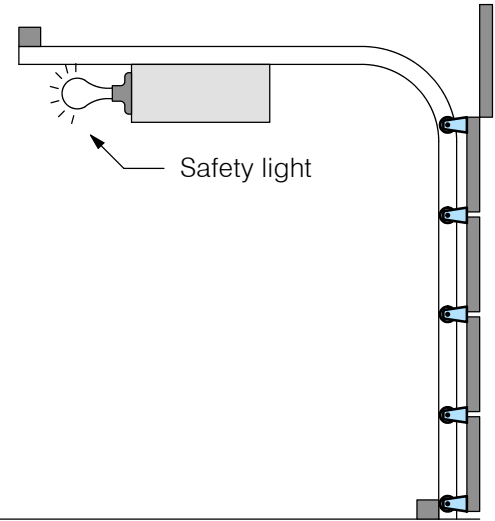

Modify the Block Diagram and State Diagram

To control the light bulb, we add an output to our controller block diagram, shown to the right, Y3 is the light control output.

In the diagram below, we add an additional state called "LIGHT". Whenever the garage owner presses the door control switch and releases, the RAISE or LOWER state is active *and the LIGHT state is simultaneously active*. The line to the Light state is dashed, because it is not the primary path.

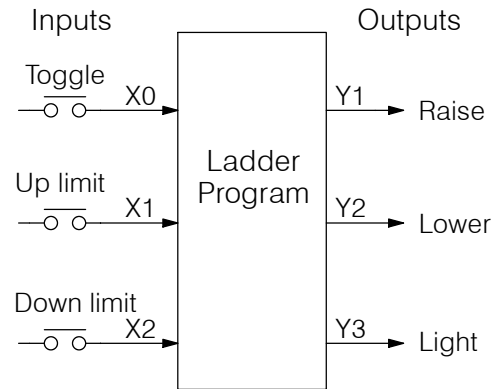

We can think of the Light state as a parallel process to the raise and lower state. The paths to the Light state are not a transition (Stage JMP), but a State Set command. In the logic of the Light stage, we will place a three-minute timer. When it expires, timer bit T0 turns on and resets the Light stage. The path out of the Light stage goes nowhere, indicating the Light stage just becomes inactive, and the light goes out!

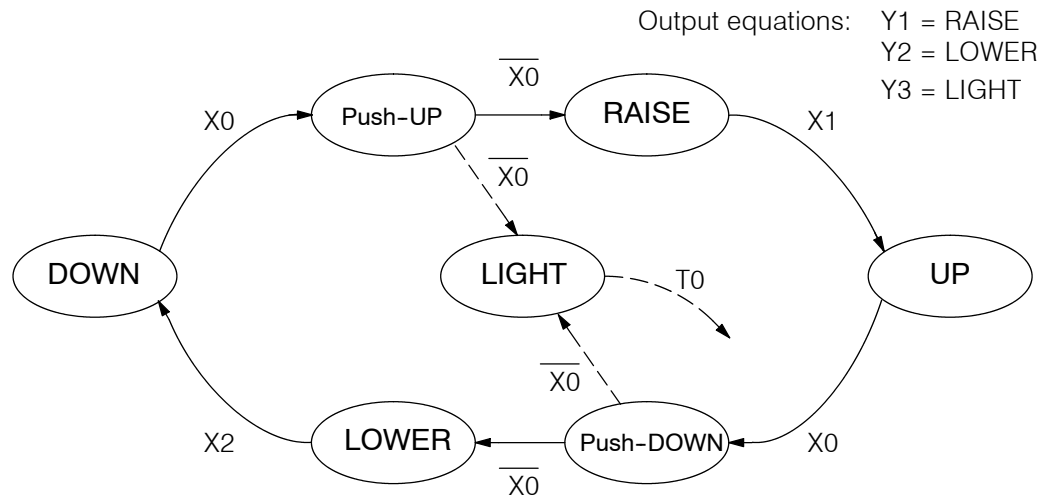

Using a Timer Inside a Stage

The finished modified program is shown to the right. The shaded areas indicate the program additions.

In the Push-UP stage S1, we add the Set Stage Bit S6 instruction. When contact X0 opens, we transition from S1 and go to two new active states: S2 and S6. In the Push-DOWN state S4, we make the same additions. So, any time someone presses the door control pushbutton, the light turns on.

Most new stage programmers would be concerned about where to place the Light Stage in the ladder, and how to number it. The good news is that it doesn't matter!

- Just choose an unused stage number, and use it for the new stage and as the reference from other stages.
- Placement in the program is not critical, so we place it at the end.

You might think that each stage has to be directly under the stage that transitions to it. While it is good practice, it is not required (that's good, because our two locations for the Set S6 instruction make that impossible). Stage numbers and how they are used determines the transition paths.

In stage S6, we turn on the safety light by energizing Y3. Special relay contact SP1 is always on. Timer T0 times at 0.1 second per count. To achieve 3 minutes time period, we calculate:

$$K = \frac{3 \text{ min.} \times 60 \text{ sec/min}}{0.1 \text{ sec/count}}$$

$$K = 1800 \text{ counts}$$

The timer has power flow whenever stage S6 is active. The corresponding timer bit T0 is set when the timer expires. So three minutes later, T0=1 and the instruction Reset S6 causes the stage to be inactive.

While Stage S6 is active and the light is on, stage transitions in the primary path continue normally and independently of Stage 6. That is, the door can go up, down, or whatever, but the light will be on for precisely 3 minutes.

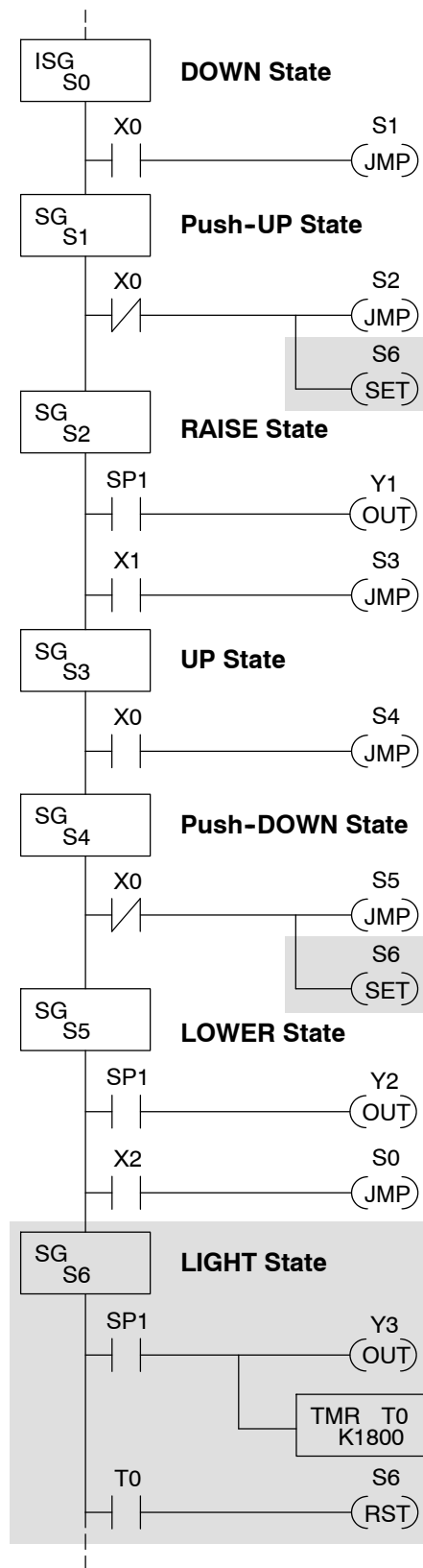

Add Emergency Stop Feature

Some garage door openers today will detect an object under the door. This halts further lowering of the door. Usually implemented with a photocell (“electric-eye”), a door in the process of being lowered will halt and begin raising. We will define our safety feature to work in this way, adding the input from the photocell to the block diagram as shown to the right. X3 will be on if an object is in the path of the door.

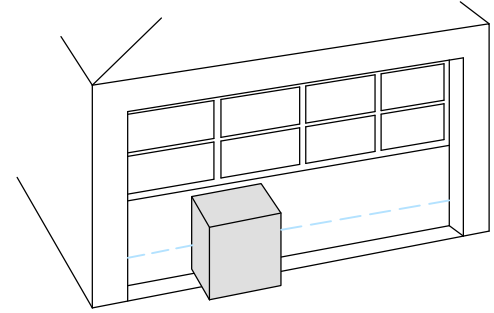

Next, we make a simple addition to the state transition diagram, shown in shaded areas in the figure below. Note the new transition path at the top of the LOWER state. If we are lowering the door and detect an obstruction (X3), we then jump to the Push-UP State. We do this instead of jumping directly to the RAISE state, to give the Lower output Y2 one scan to turn off, before the Raise output Y1 energizes.

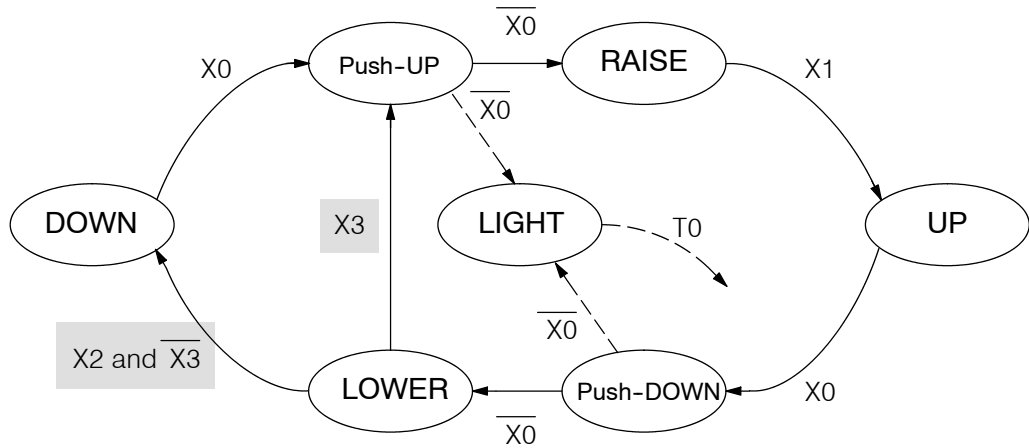
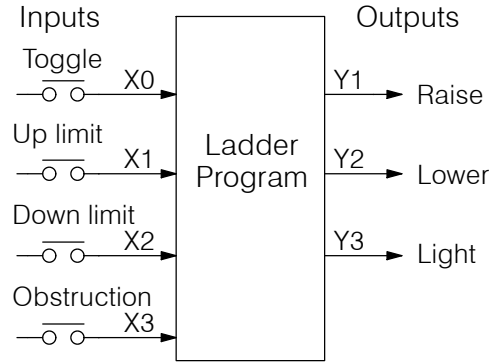

Exclusive Transitions

It is theoretically possible that the down limit (X2) and the obstruction input (X3) could energize at the same moment. In that case, we would “jump” to the Push-UP and DOWN states simultaneously, which does not make sense.

Instead, we give priority to the obstruction by changing the transition condition to the DOWN state to [X2 AND NOT X3]. This ensures the obstruction event has the priority. The modifications we must make to the LOWER stage (S5) logic are shown to the right. The first rung remains unchanged. The second and third rungs implement the transitions we need. Note the opposite relay contact usage for X3, which ensures the stage will execute only one of the JMP instructions.

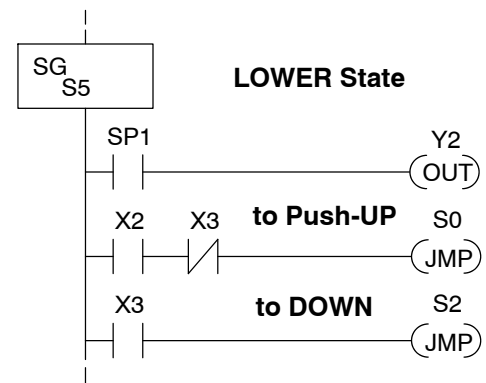

Stage Program Design Considerations

Stage Program Organization

The examples so far in this chapter used one self-contained state diagram to represent the main process. However, we can have multiple processes implemented in stages, all in the same ladder program. New stage programmers sometimes try to turn a stage on and off each scan, based on the false assumption that only one stage can be on at a time. For ladder rungs that you want to execute each scan, just put them in a stage that is always on.

The following figure shows a typical application. During operation, the primary manufacturing activity Main Process, Powerup Initialization, E-Stop and Alarm Monitoring, and Operator Interface are all running. At powerup, three initial stages shown begin operation.

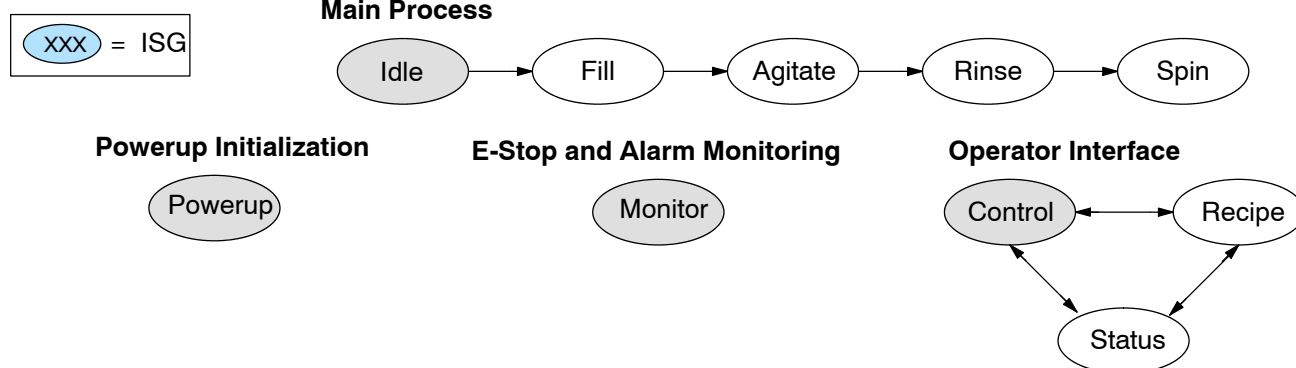

In a typical application, the separate stage sequences above operate as follows:

- **Powerup Initialization** - This stage contains ladder rung tasks done just once at powerup. Its last rung resets the stage, so this stage is only active for one scan (or only as many scans that are required).
- **Main Process** - this stage sequence controls the heart of the process or machine. One pass through the sequence represents one part cycle of the machine, or one batch in the process.
- **E-Stop and Alarm Monitoring** - This stage is always active because it is watching for errors that could indicate an alarm condition or require an emergency stop. It is common for this stage to reset stages in the main process or elsewhere, in order to initialize them after an error condition.
- **Operator Interface** - this is another task that must always be active and ready to respond to an operator. It allows an operator interface to change modes, etc. independently of the current main process step.

Although we have separate processes, there can be coordination among them. For example, in an error condition, the Status Stage may want to automatically switch the operator interface to the status mode to show error information as shown to the right. The monitor stage could set the stage bit for Status and Reset the stages Control and Recipe.

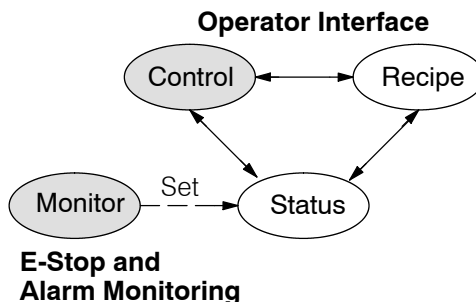

How Instructions Work Inside Stages

We can think of states or stages as simply dividing up our ladder program as depicted in the figure below. Each stage contains only the ladder rungs which are needed for the corresponding state of the process. The logic for transitioning out of a stage is contained within that stage. It's easy to choose which ladder rungs are active at powerup by using an "initial" stage type (ISG).

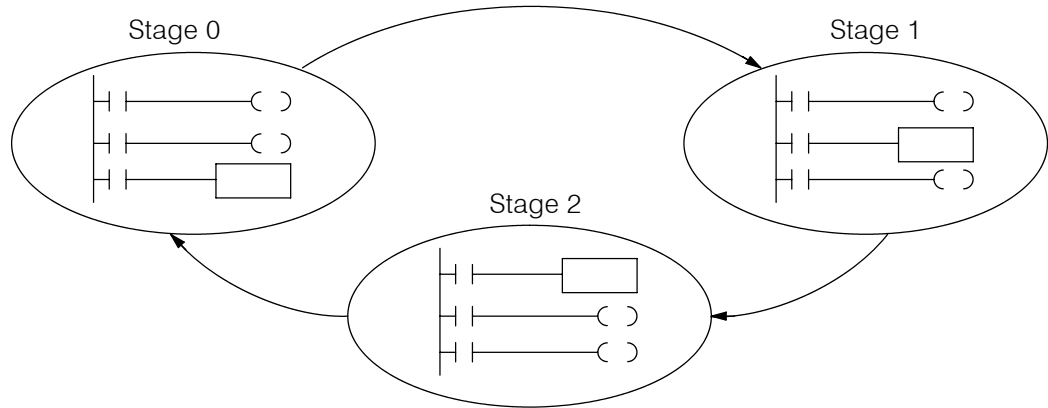

Most all instructions work just like they do in standard RLL. You can think of a stage just like a miniature RLL program which is either active or inactive.

Output Coils - As expected, output coils in active stages will turn on or off outputs according to power flow into the coil. However, note the following:

- Outputs work as usual, provided each output reference (such as "Y3") is used in only one stage.
- An output can be referenced from more than one stage, as long as only one of the stages is active at a time.
- If an output coil is controlled by more than one stage simultaneously, the active stage nearest the bottom of the program determines the final output status during each scan. Therefore, use the OROUT instruction instead when you want multiple stages to have a logical OR control of an output.

One-Shot or PD coils - Use care if you must use a Positive Differential coil in a stage. Remember that the input to the coil must make a 0-1 transition. If the coil is already energized on the first scan when the stage becomes active, the PD coil will not work. This is because the 0-1 transition did not occur.

PD coil alternative: If there is a task which you want to do only once (on 1 scan), it can be placed in a stage which transitions to the next stage on the same scan.

Counter - In using a counter inside a stage, the stage must be active for one scan before the input to the counter makes a 0-1 transition. Otherwise, there is no real transition and the counter will not count.

The ordinary Counter instruction does have a restriction inside stages: it may not be reset from other stages using the RST instruction for the counter bit. However, the special Stage Counter provides a solution (see next paragraph).

Stage Counter - The Stage Counter has the benefit that its count may be globally reset from other stages by using the RST instruction. It has a count input, but no reset input. This is the only difference from a standard counter.

Drum - Realize that the drum sequencer is its own process, and is a different programming method than stage programming. If you need to use a drum with stages, be sure to place the drum instruction in an ISG stage that is always active.

Using a Stage as a Supervisory Process

You may recall the light bulb on-off controller example from earlier in this chapter. For the purpose of illustration, suppose we want to monitor the “productivity” of the lamp process, by counting the number of on-off cycles which occurs. This application will require the addition of a simple counter, but the key decision is in where to put the counter.

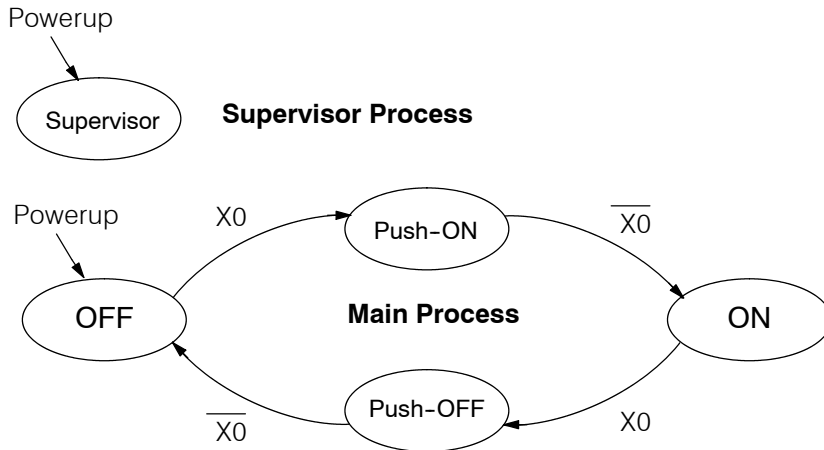
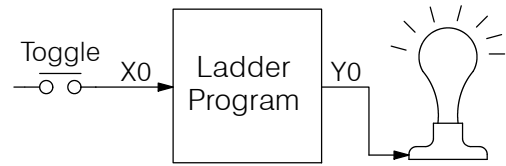

New stage programming students will typically try to place the counter inside one of the stages of the process they are trying to monitor. The problem with this approach is that the stage is active only part of the time. In order for the counter to count, the count input must transition from off to on at least one scan after its stage activates. Ensuring this requires extra logic that can be tricky.

In this case, we only need to add another supervisory stage as shown above, to “watch” the main process. The counter inside the supervisor stage uses the stage bit S1 of the main process as its count input. *Stage bits used as a contact let us monitor a process!*

Note that both the Supervisor stage and the OFF stage are initial stages. The supervisor stage remains active indefinitely.

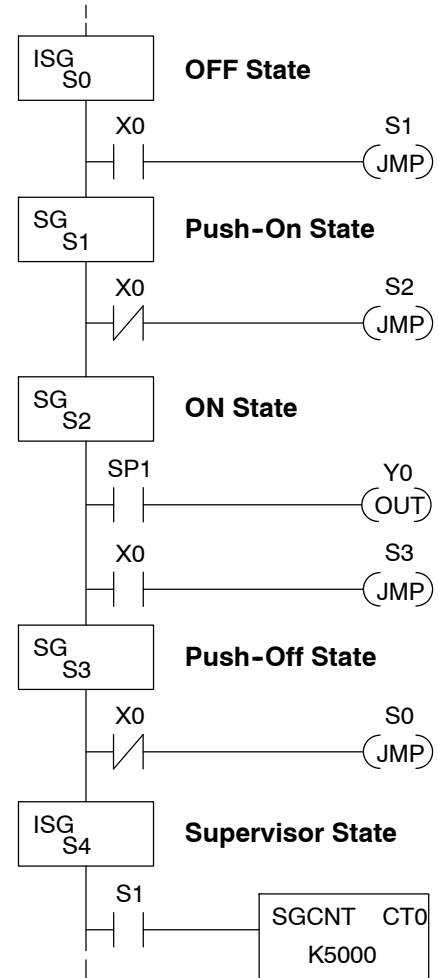

RLL^{PLUS} Stage Programming

Stage Counter

The counter in the above example is a special Stage Counter. Note that it does not have a reset input. The count is reset by executing a Reset instruction, naming the counter bit (CT0 in this case). The Stage Counter has the benefit that its count may be globally reset from other stages. The standard Counter instruction does not have this global reset capability. You may still use a regular Counter instruction inside a stage... however, the reset input to the counter is the only way to reset it.

Power Flow Transition Technique

Our discussion of state transitions has shown how the stage JMP instruction makes the current stage inactive and the next stage (named in the JMP) active. As an alternative way to enter this in *DirectSOFT*, you may use the power flow method for stage transitions.

The main requirement is that the current stage be located directly above the next (jump-to) stage in the ladder program. This arrangement is shown in the diagram below, by stages S0 and S1, respectively.

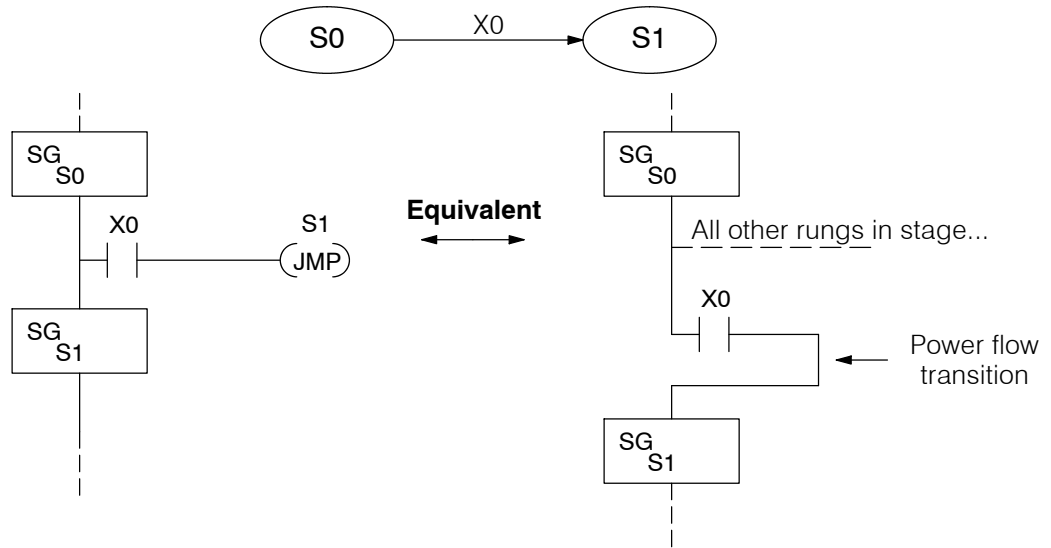

Recall that the stage JMP instruction may occur anywhere in the current stage, and the result is the same. However, power flow transitions (shown above) must occur as the last rung in a stage. All other rungs in the stage will precede it. The power flow transition method is also achievable on the handheld programmer, by simply following the transition condition with the stage instruction for the next stage.

The power flow transition method does eliminate one stage JMP instruction, its only advantage. However, it is not as easy to make program changes as using the stage JMP. Therefore, we advise using stage JMP transitions for most programmers.

Stage View in DirectSOFT

The stage View option in *DirectSOFT* will let you view the ladder program as a flow chart. The figure below shows the symbol convention used in the diagrams. You may find the stage view useful as a tool to verify that your stage program has faithfully reproduced the logic of the state transition diagram you intend to realize.

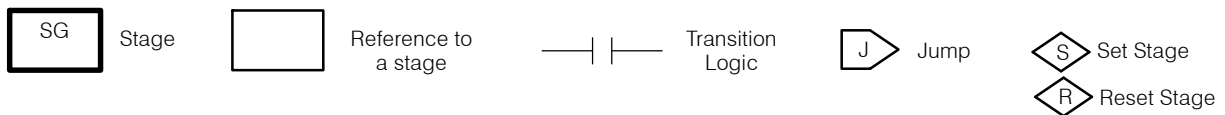

The following diagram is a typical stage view of a ladder program containing stages. Note the left-to-right direction of the flow chart.

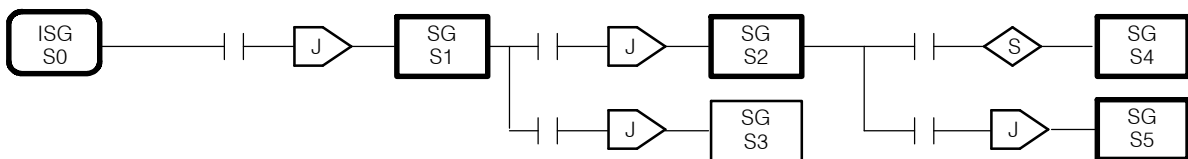

RLL^{PLUS} Stage Instructions

Stage (SG)

The Stage instructions are used to create structured RLL^{PLUS} programs. Stages are program segments which can be activated by transitional logic, a jump or a set stage that is executed from an active stage. Stages are deactivated one scan after transitional logic, a jump, or a reset stage instruction is executed.

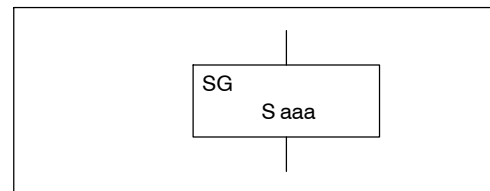

Operand Data Type	DL130 Range
	aaa
Stage S	0-377

The following example is a simple RLL^{PLUS} Stage program. This program utilizes an initial stage, and jump instructions to create a structured program.

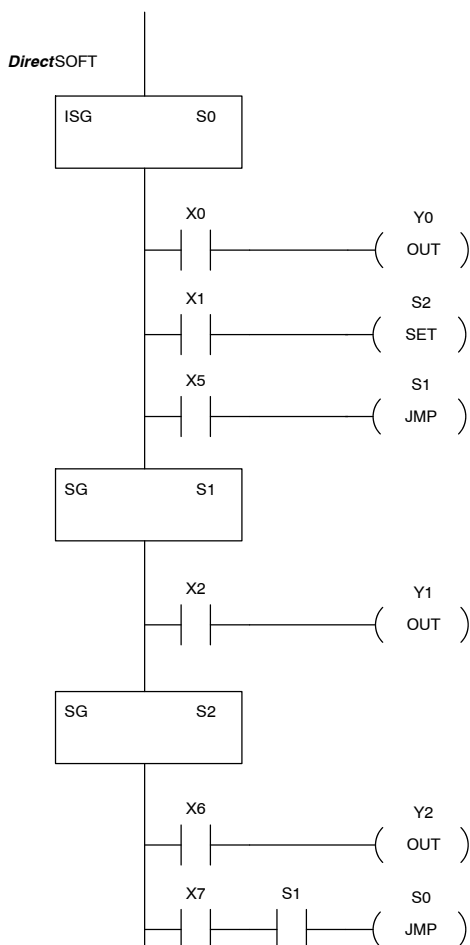

Handheld Programmer Keystrokes

U ISG	→	A 0	ENT
\$ STR	→	A 0	ENT
GX OUT	→	A 0	ENT
\$ STR	→	B 1	ENT
X SET	→	SHFT S RST	C 2 ENT
\$ STR	→	F 5	ENT
K JMP	→	B 1	ENT
2 SG	→	B 1	ENT
\$ STR	→	C 2	ENT
GX OUT	→	B 1	ENT
2 SG	→	C 2	ENT
\$ STR	→	G 6	ENT
GX OUT	→	C 2	ENT
\$ STR	→	H 7	ENT
V AND	→	SHFT S RST	B 1 ENT
K JMP	→	A 0	ENT

Initial Stage (ISG)

The Initial Stage instruction is normally used as the first segment of an RLL^{PLUS} Stage program. Multiple Initial Stages are allowed in a program. They will be active when the CPU enters the Run mode allowing for a starting point in the program. Initial Stages are also activated by transitional logic, a jump or a set stage executed from an active stage.

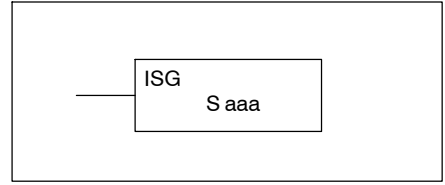

Operand Data Type		DL130 Range
		aaa
Stage	S	0-377

NOTE: If the ISG is within the retentive range for stages, the ISG will remain in the state it was in before power down and will NOT turn itself on during the first scan.



JUMP (JMP)

The Jump instruction allows the program to transition from an active stage containing the jump instruction to another stage (specified in the instruction). The jump occurs when the input logic is true. The active stage containing the Jump will deactivate 1 scan later.

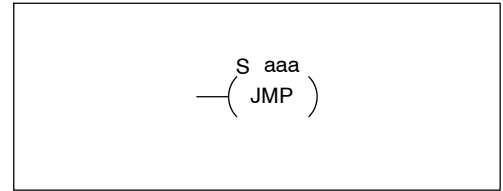

Operand Data Type		DL130 Range
		aaa
Stage	S	0-377

In the following example, only stage ISG0 will be active when program execution begins. When X1 is on, program execution will jump from Initial Stage 0 to Stage 1.

DirectSOFT

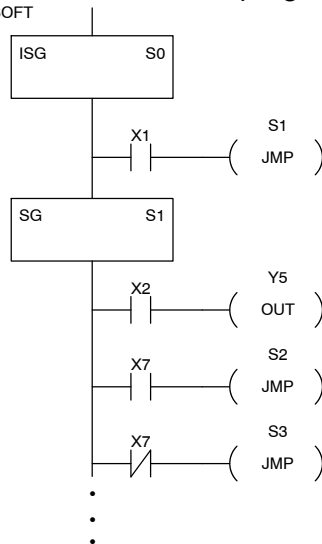

Handheld Programmer Keystrokes

U	ISG	→	A	0	ENT				
\$	STR	→	B	1	ENT				
K	JMP	→	B	1	ENT				
2	SG	→	B	1	ENT				
\$	STR	→	C	2	ENT				
GX	OUT	→	F	5	ENT				
\$	STR	→	H	7	ENT				
K	JMP	→	C	2	ENT				
SHFT	N	TMR	SHFT	K	JMP	→	D	3	ENT



NOTE: The F1-130 CPU does not have the Not Jump instruction (as does other PLC families). You may still achieve the same result by using the Jump instruction, while inverting the sense of contact logic that activates that instruction.

Questions and Answers about Stage Programming

We include the following commonly-asked questions about Stage Programming as an aid to new students. All question topics are covered in more detail in this chapter.

Q. What does stage programming do that I can't do with regular RLL programs?

A. Stages allow you to identify all the states of your process before you begin programming. This approach is more organized, because you divide up a ladder program into sections. As stages, these program sections are active only when they are actually needed by the process. Most processes can be organized into a sequence of stages, connected by event-based transitions.

Q. Isn't a stage really just like a software subroutine?

A. No, it is very different. A subroutine is called by a main program when needed, and executes just once before returning to the point from which it was called. A stage, however, is part of the main program. It represents a state of the process, so an active stage executes on every scan of the CPU until it becomes inactive.

Q. What are Stage Bits?

A. A stage bit is just a single bit in the CPU's image register, representing the active/inactive status of the stage in real time. For example, the bit for Stage 0 is referenced as "S0". If S0 = 0, then the ladder rungs in Stage 0 are bypassed (not executed) on each CPU scan. If S0 = 1, then the ladder rungs in Stage 0 are executed on each CPU scan. Stage bits, when used as contacts, allow one part of your program to monitor another part by detecting stage active/inactive status.

Q. How does a stage become active?

A. There are three ways:

- If the Stage is an initial stage (ISG), it is automatically active at powerup.
- Another stage can execute a stage JMP instruction naming this stage, which makes it active upon its next occurrence in the program.
- A program rung can execute a Set Stage Bit instruction (such as Set S0).

Q. How does a stage become inactive?

A. There are three ways:

- Standard Stages (SG) are automatically inactive at powerup.
- A stage can execute a stage JMP instruction, resetting its Stage Bit to 0.
- Any rung in the program can execute a Reset Stage Bit instruction (such as Reset S0).

Q. What about the power flow technique of stage transitions?

A. The power flow method of connecting adjacent stages (directly above or below in the program) actually is the same as the stage Jump instruction executed in the stage above, naming the stage below. Power flow transitions are more difficult to edit in *DirectSOFT*, we list them separately from two preceding questions.

Q. Can I have a stage which is active for only one scan?

A. Yes, but this is not the intended use for a stage. Instead, just make a ladder rung active for 1 scan by including a stage Jump instruction at the bottom of the rung. Then the ladder will execute on the last scan before its stage jumps to a new one.

Q. Isn't a stage JMP just like a regular GOTO instruction used in software?

A. No, it is very different. A GOTO instruction sends the program execution immediately to the code location named by the GOTO. A stage JMP simply resets the stage Bit of the current stage, while setting the stage Bit of the stage named in the JMP instruction. Stage bits are 0 or 1, determining the inactive/active status of the corresponding stages. A stage JMP has the following results:

- When the JMP is executed, the remainder of the current stage's rungs are executed, even if they reside past (under) the JMP instruction. On the following scan, that stage is not executed, because it is inactive.
- The stage named in the stage JMP instruction will be executed upon its next occurrence. If located past (under) the current stage, it will be executed on the same scan. If located before (above) the current stage, it will be executed on the following scan.

Q. How can I know when to use stage JMP, versus a Set Stage Bit or Reset Stage Bit?

A. These instructions are used according to the state diagram topology you have derived:

- Use a stage JMP instruction for a state transition... moving from one state to another.
- Use a Set Stage Bit instruction when the current state is spawning a new parallel state or stage sequence, or when a supervisory state is starting a state sequence under its command.
- Use a Reset Bit instruction when the current state is the last state in a sequence and its task is complete, or when a supervisory state is ending a state sequence under its command.

Q. What is an initial stage, and when do I use it?

A. An initial stage (ISG) is automatically active at powerup. Afterwards, it works just like any other stage. You can have multiple initial stages, if required. Use an initial stage for ladder that must always be active, or as a starting point.

Q. Can I have place program ladder rungs outside of the stages, so they are always on?

A. It is possible, but it's not good software design practice. Place ladder that must always be active in an initial stage, and do not reset that stage or use a stage JMP instruction inside it. It can start other stage sequences at the proper time by setting the appropriate stage Bit(s).

Q. Can I have more than one active stage at a time?

A. Yes, and this is a normal occurrence for many programs. However, it is important to organize your application into separate processes, each made up of stages. And a good process design will be mostly sequential, with only one stage on at a time. However, all the processes in the program may be active simultaneously.