

cod. 5807172

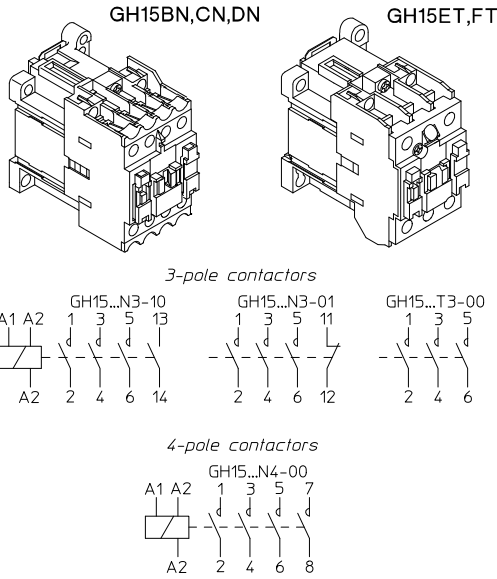

PERFORMANCE ACCORDING TO cULus

Contactor type		GH15BN	GH15CN	GH15DN	GH15ET	GH15FT
Insulation voltage	AC V	600				
General use current	A	20	20	25	40	45
Max. power of three-phase motors 60Hz	200V HP	2	3	3	7.5	7.5
	230V HP	3	3	5	7.5	10
	460V HP	5	7.5	10	15	20
	575V HP	7.5	10	15	20	25
Max. power of single-phase motors 60Hz	115V HP	0.5	0.5	1	2	2
	230V HP	1	2	3	3	5
Auxiliary contacts		Rated voltage: 600V AC    Switching capacity: A600				

PERFORMANCE ACCORDING TO IEC

Contactor type		GH15BN	GH15CN	GH15DN	GH15ET	GH15FT
Insulation voltage	AC V	690				
Resistive loads AC-1 cat. (open)	A	30	30	30	45	50
Max. power of 50-60Hz three-phase motors	230V kW	2.2	3	4	6.5	7.5
	400V kW	4	5.5	7.5	11	15
AC-3 category	440V kW	4.7	6.4	9	12.5	16.5
	500V kW	5.5	7.5	10	11	15
	690V kW	5.5	7.5	7.5	11	15

Overall dimensions and mounting specifications in mm (inches)

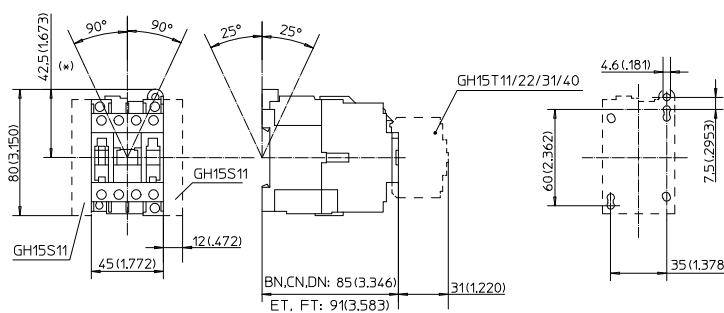

(\*) When DIN rail is not mounted horizontal, use an End Bracket (DN-EB35) or equivalent to secure contactor(s).

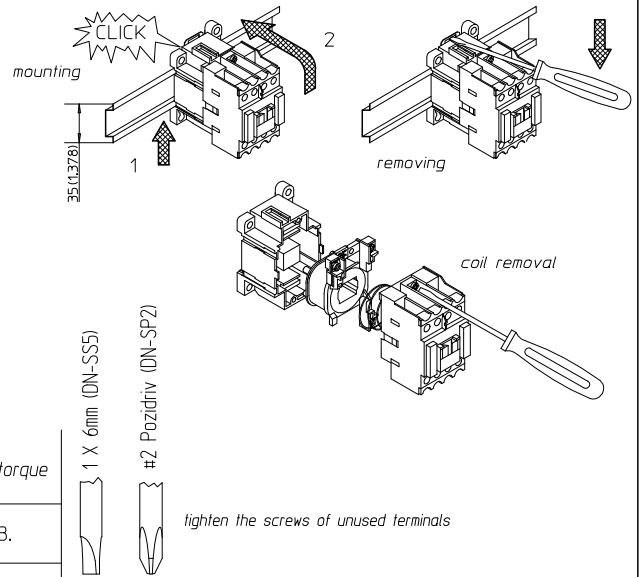

Main circuit connections Use 75°C copper wire only	Size of cable (AWG)		Tightening torque
	Stranded	Solid	
GH15BN,CN,DN	10 - 14	-	12 IN LB.
GH15ET,FT	8 - 14	-	20 IN LB.
Auxiliary circuit connections	12 - 16	12 - 14	7 IN LB.

		<p><b>WARNING:</b>                  Electrical Shock Hazard                  Installation and maintenance by qualified personnel only.                  Remove power before servicing. Follow the operating instructions.</p>
--	--	---

**MOUNTING**

- Do not mount or remove contactor with power connected.
- Provide adequate circuit protection (fuses, circuit breakers) on the supply side of the contactor.
- Working position in the vertical plane: As shown in the drawings.
- Minimum spacing between contactors mounted in a row: 5mm.
- Installation: Check for unrestricted make/break action by manually actuating contactor (POWER OFF) after installation.
- Ensure that control voltage remains within 85%-110% of rated coil voltage.
- Ensure that components driving the coil (switches, control relays, output modules) do not cause unsteady operation of the coil resulting in erratic make/break action of the contactor.

**MAINTENANCE**

- Noise from the coil indicates that debris has entered the contactor coil area. (Pieces of wire, insulation, iron filings, etc.), to remove debris, remove disconnect the contactor, disassemble the contactor and clean the actuator surfaces.
  - GH15BN-GH15DN Contactors  
 If light contact welding occurs, break the weld by opening the contactor and pressing the movable core.
  - GH15ET and GH15FT Contactors  
 1.Periodically check for contact wear. The ET and FT contactors can be disassembled down to the contacts.  
 2.If light contact welding occurs, separate the contacts with a screwdriver.
- CONTACT WELDING OCCURS WITH HIGH CURRENT CONDITIONS. INVESTIGATE THE CAUSE OF CONTACT WELDING.**

ACCESSORIES

SIDE MOUNTING  
 AUXILIARY CONTACT  
 BLOCKS  
 (maximum 2 per contactor)

Part Number    Contact Types  
 GH15S11        1NO-1NC

MECHANICAL  
 INTERLOCK  
 Part Number  
 BMOH

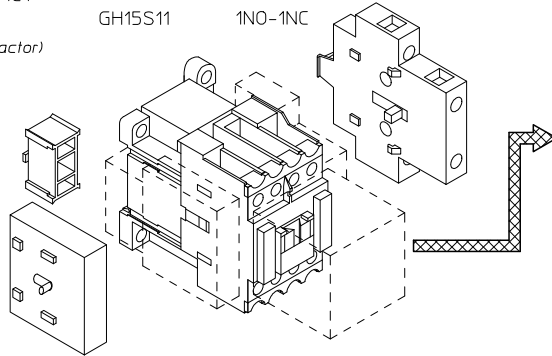

TOP MOUNTING  
 AUXILIARY CONTACT BLOCKS

Part Number    Contact Types  
 GH15T40        4NO  
 GH15T31        3NO-1NC  
 GH15T22        2NO-2NC  
 GH15T11        1NO-1NC

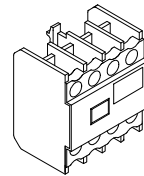

*BMOH mechanical interlock assembly instructions*

1. Fit the mechanical interlock 1 on one side of the contactor, as shown, by inserting the driving pin into the notch of the movable part of the contactor
  2. Connect the second contactor by repeating the above
  3. Join the contactors by inserting the block 2
  4. Check the interlock by driving the contactors manually
- \* This procedure requires a "feel" for the process. **PRATICE & PATIENCE** is the key.

