



C-MORE CM5-RHMI SERIES HARDWARE USER MANUAL

CM5-RHMI-USER-M



**BLANK
PAGE**

Warnings and Trademarks

~ WARNING ~

Thank you for purchasing automation equipment from Automationdirect.com®, doing business as AutomationDirect. We want your new automation equipment to operate safely. Anyone who installs or uses this equipment should read this publication (and any other relevant publications) before installing or operating the equipment.

To minimize the risk of potential safety problems, you should follow all applicable local and national codes that regulate the installation and operation of your equipment. These codes vary from area to area and usually change with time. It is your responsibility to determine which codes should be followed, and to verify that the equipment, installation, and operation is in compliance with the latest revision of these codes.

At a minimum, you should follow all applicable sections of the National Fire Code, National Electrical Code, and the codes of the National Electrical Manufacturer's Association (NEMA). There may be local regulatory or government offices that can also help determine which codes and standards are necessary for safe installation and operation.

Equipment damage or serious injury to personnel can result from the failure to follow all applicable codes and standards. We do not guarantee the products described in this publication are suitable for your particular application, nor do we assume any responsibility for your product design, installation, or operation.

Our products are not fault-tolerant and are not designed, manufactured or intended for use or resale as on-line control equipment in hazardous environments requiring fail-safe performance, such as in the operation of nuclear facilities, aircraft navigation or communication systems, air traffic control, direct life support machines, or weapons systems, in which the failure of the product could lead directly to death, personal injury, or severe physical or environmental damage ("High Risk Activities"). AutomationDirect specifically disclaims any expressed or implied warranty of fitness for High Risk Activities.

For additional warranty and safety information, see the Terms and Conditions section of our catalog. If you have any questions concerning the installation or operation of this equipment, or if you need additional information, please call us at **770-844-4200**.

This publication is based on information that was available at the time it was printed. At AutomationDirect we constantly strive to improve our products and services, so we reserve the right to make changes to the products and/or publications at any time without notice and without any obligation. This publication may also discuss features that may not be available in certain revisions of the product.

Trademarks

This publication may contain references to products produced and/or offered by other companies. The product and company names may be trademarked and are the sole property of their respective owners. AutomationDirect disclaims any proprietary interest in the marks and names of others.

**Copyright 2023 Automationdirect.com® Incorporated
All Rights Reserved**

No part of this manual shall be copied, reproduced, or transmitted in any way without the prior, written consent of Automationdirect.com® Incorporated. AutomationDirect retains the exclusive rights to all information included in this document.

~ ADVERTENCIA ~

Gracias por comprar equipo de automatización de Automationdirect.com®. Deseamos que su nuevo equipo de automatización opere de manera segura. Cualquier persona que instale o use este equipo debe leer esta publicación (y cualquier otra publicación pertinente) antes de instalar u operar el equipo.

Para reducir al mínimo el riesgo debido a problemas de seguridad, debe seguir todos los códigos de seguridad locales o nacionales aplicables que regulan la instalación y operación de su equipo. Estos códigos varían de área en área y usualmente cambian con el tiempo. Es su responsabilidad determinar cuales códigos deben ser seguidos y verificar que el equipo, instalación y operación estén en cumplimiento con la revisión más reciente de estos códigos.

Como mínimo, debe seguir las secciones aplicables del Código Nacional de Incendio, Código Nacional Eléctrico, y los códigos de (NEMA) la Asociación Nacional de Fabricantes Eléctricos de USA. Puede haber oficinas de normas locales o del gobierno que pueden ayudar a determinar cuales códigos y normas son necesarios para una instalación y operación segura.

Si no se siguen todos los códigos y normas aplicables, puede resultar en daños al equipo o lesiones serias a personas. No garantizamos los productos descritos en esta publicación para ser adecuados para su aplicación en particular, ni asumimos ninguna responsabilidad por el diseño de su producto, la instalación u operación.

Nuestros productos no son tolerantes a fallas y no han sido diseñados, fabricados o intencionados para uso o reventa como equipo de control en línea en ambientes peligrosos que requieren una ejecución sin fallas, tales como operación en instalaciones nucleares, sistemas de navegación aérea, o de comunicación, control de tráfico aéreo, máquinas de soporte de vida o sistemas de armamentos en las cuales la falla del producto puede resultar directamente en muerte, heridas personales, o daños físicos o ambientales severos (“Actividades de Alto Riesgo”). **Automationdirect.com** específicamente rechaza cualquier garantía ya sea expresada o implicada para actividades de alto riesgo.

Para información adicional acerca de garantía e información de seguridad, vea la sección de Términos y Condiciones de nuestro catálogo. Si tiene alguna pregunta sobre instalación u operación de este equipo, o si necesita información adicional, por favor llámenos al número 770-844-4200 en Estados Unidos.

Esta publicación está basada en la información disponible al momento de impresión. En **Automationdirect.com** nos esforzamos constantemente para mejorar nuestros productos y servicios, así que nos reservamos el derecho de hacer cambios al producto y/o a las publicaciones en cualquier momento sin notificación y sin ninguna obligación. Esta publicación también puede discutir características que no estén disponibles en ciertas revisiones del producto.

Marcas Registradas

Esta publicación puede contener referencias a productos producidos y/u ofrecidos por otras compañías. Los nombres de las compañías y productos pueden tener marcas registradas y son propiedad única de sus respectivos dueños. Automationdirect.com, renuncia cualquier interés propietario en las marcas y nombres de otros.

Propiedad Literaria 2023, Automationdirect.com® Incorporated

Todos los derechos reservados

No se permite copiar, reproducir, o transmitir de ninguna forma ninguna parte de este manual sin previo consentimiento por escrito de **Automationdirect.com® Incorporated. Automationdirect.com** retiene los derechos exclusivos a toda la información incluida en este documento. Los usuarios de este equipo pueden copiar este documento solamente para instalar, configurar y mantener el equipo correspondiente. También las instituciones de enseñanza pueden usar este manual para propósitos educativos.

~ AVERTISSEMENT ~

Nous vous remercions d'avoir acheté l'équipement d'automatisation de Automationdirect.com®, en faisant des affaires comme AutomationDirect. Nous tenons à ce que votre nouvel équipement d'automatisation fonctionne en toute sécurité. Toute personne qui installe ou utilise cet équipement doit lire la présente publication (et toutes les autres publications pertinentes) avant de l'installer ou de l'utiliser.

Afin de réduire au minimum le risque d'éventuels problèmes de sécurité, vous devez respecter tous les codes locaux et nationaux applicables régissant l'installation et le fonctionnement de votre équipement. Ces codes diffèrent d'une région à l'autre et, habituellement, évoluent au fil du temps. Il vous incombe de déterminer les codes à respecter et de vous assurer que l'équipement, l'installation et le fonctionnement sont conformes aux exigences de la version la plus récente de ces codes.

Vous devez, à tout le moins, respecter toutes les sections applicables du Code national de prévention des incendies, du Code national de l'électricité et des codes de la National Electrical Manufacturer's Association (NEMA). Des organismes de réglementation ou des services gouvernementaux locaux peuvent également vous aider à déterminer les codes ainsi que les normes à respecter pour assurer une installation et un fonctionnement sûrs.

L'omission de respecter la totalité des codes et des normes applicables peut entraîner des dommages à l'équipement ou causer de graves blessures au personnel. Nous ne garantissons pas que les produits décrits dans cette publication conviennent à votre application particulière et nous n'assumons aucune responsabilité à l'égard de la conception, de l'installation ou du fonctionnement de votre produit.

Nos produits ne sont pas insensibles aux défaillances et ne sont ni conçus ni fabriqués pour l'utilisation ou la revente en tant qu'équipement de commande en ligne dans des environnements dangereux nécessitant une sécurité absolue, par exemple, l'exploitation d'installations nucléaires, les systèmes de navigation aérienne ou de communication, le contrôle de la circulation aérienne, les équipements de survie ou les systèmes d'armes, pour lesquels la défaillance du produit peut provoquer la mort, des blessures corporelles ou de graves dommages matériels ou environnementaux («activités à risque élevé»). La société AutomationDirect nie toute garantie expresse ou implicite d'aptitude à l'emploi en ce qui a trait aux activités à risque élevé.

Pour des renseignements additionnels touchant la garantie et la sécurité, veuillez consulter la section Modalités et conditions de notre documentation. Si vous avez des questions au sujet de l'installation ou du fonctionnement de cet équipement, ou encore si vous avez besoin de renseignements supplémentaires, n'hésitez pas à nous téléphoner au **770-844-4200**.

Cette publication s'appuie sur l'information qui était disponible au moment de l'impression. À la société AutomationDirect, nous nous efforçons constamment d'améliorer nos produits et services. C'est pourquoi nous nous réservons le droit d'apporter des modifications aux produits ou aux publications en tout temps, sans préavis ni quelque obligation que ce soit. La présente publication peut aussi porter sur des caractéristiques susceptibles de ne pas être offertes dans certaines versions révisées du produit.

Marques de commerce

La présente publication peut contenir des références à des produits fabriqués ou offerts par d'autres entreprises. Les désignations des produits et des entreprises peuvent être des marques de commerce et appartiennent exclusivement à leurs propriétaires respectifs. AutomationDirect nie tout intérêt dans les autres marques et désignations.

*Copyright 2023 Automationdirect.com® Incorporated
Tous droits réservés*

Nulle partie de ce manuel ne doit être copiée, reproduite ou transmise de quelque façon que ce soit sans le consentement préalable écrit de la société Automationdirect.com® Incorporated. AutomationDirect conserve les droits exclusifs à l'égard de tous les renseignements contenus dans le présent document.

**BLANK
PAGE**



MANUAL REVISION HISTORY

Please include the Manual Number and the Manual Issue, both shown below, when communicating with Technical Support regarding this publication.

Manual Number: CM5-RHMI-USER-M
Issue: 1st Edition
Issue Date: 07/2024

Publication History		
<i>Issue</i>	<i>Date</i>	<i>Description of Changes</i>
First Edition	07/2024	Original

**BLANK
PAGE**



USER MANUAL TABLE OF CONTENTS

- Chapter 1: Getting Started..... 1-1**
 - Introduction..... 1-2
 - Supplemental Manuals..... 1-2
 - Technical Support 1-2
 - Conventions Used 1-3
 - Product Overview 1-4
 - Quick Start Steps 1-5
 - C-more** LED Status Indicators..... 1-11

- Chapter 2: Specifications..... 2-1**
 - Specifications 2-2
 - Communication Ports and Memory Expansion 2-5
 - Communication Ports 2-6
 - User Defined LED..... 2-8
 - Compatible Touch Screen Monitors..... 2-9
 - Handling External Memory Devices 2-10
 - Writing to External Memory devices 2-10
 - Minimizing Data Errors 2-11
 - Monitoring Available Memory..... 2-12
 - Power Loss Retention..... 2-12
 - Watchdog Timeout..... 2-13

- Chapter 3: Accessories..... 3-1**
 - Accessories Overview 3-2
 - D-SUB 15-pin to Terminal Block Adapter 3-3
 - SD Card 3-4
 - USB FLASH Drive 3-4

- Chapter 4: Installation and Wiring 4-1**
 - Safety Guidelines 4-2
 - Introduction..... 4-3
 - Mounting 4-4
 - Wiring Guidelines 4-6
 - Agency Approvals..... 4-6
 - Providing Power to the HMI 4-7
 - C-more** LED Status Indicators..... 4-8

Chapter 5: System Setup Screens	5-1
Introduction.....	5-4
Information	5-4
Settings.....	5-4
Test Menu.....	5-4
Memory.....	5-4
Accessing the System Setup Screens (no project loaded).....	5-5
Accessing the System Setup Screens (with project loaded).....	5-6
Using RHMI USB Remote	5-7
System Setup Screens	5-9
Password Protecting System Screen Access.....	5-9
System Setup Screens - Enable Password in Software	5-10
System Setup Screens Flowchart	5-16
Main Menu	5-17
Information Screen	5-18
Information - Ethernet Tab	5-20
Settings Screen	5-23
Settings - Options	5-30
Test Menu	5-31
Test Menu - Test Touch Panel.....	5-32
Test Menu - Test Beep/Audio	5-33
Test Menu - Test Serial Port	5-34
Test Menu - PLC Serial Comm Port - Loop back test.....	5-35
Memory Screen	5-42
Memory - Backup.....	5-44
Memory - Restore.....	5-49
Memory - Clear Memory	5-53
Memory - Reset to Factory Default	5-57
Chapter 6: PLC Communications	6-1
Introduction.....	6-2
DirectLOGIC PLCs Password Protection	6-2
PLC Protocols.....	6-3
PLC Communication Cables & Wiring Diagrams	6-5
AutomationDirect PLCs RS-232C Serial Cables Wiring Diagrams	6-7
AutomationDirect PLCs PLCs RS-422A/RS-485A Cables Wiring Diagrams.....	6-9
Allen-Bradley PLCs RS-232C/RS-485A Serial Cables Wiring Diagrams	6-19
GE PLCs RS-422/RS-232C Serial Cables Wiring Diagrams.....	6-22
Mitsubishi PLCs RS-422/RS-232C Serial Cables Wiring Diagrams	6-23
Omron PLCs RS-232C Serial Cables Wiring Diagrams.....	6-25
Modicon PLCs RS-232C Serial Cables Wiring Diagrams.....	6-26
Siemens PLCs RS-485A Serial Cables Wiring Diagrams	6-27

Chapter 7: Maintenance	7-1
Maintenance	7-2
Project Backup.....	7-2
Check Operating Environment.....	7-2
Check Operating Voltage.....	7-2
Check Status Indicators.....	7-2
Check Physical Conditions.....	7-2
Run Tests under System Setup Screens.....	7-3
Check Memory Usage	7-4
Check Error Log.....	7-4
Check Project Functionality.....	7-5
Checks from <i>C-more</i> Programming Software	7-5
Chapter 8: Troubleshooting	8-1
Common Problems	8-2
Troubleshooting Flow Chart	8-3
HMI Does Not Power Up	8-4
<i>C-more</i> LED Status Indicators	8-5
General Errors and Warnings	8-6
No User Program	8-8
Select Touch Panel Driver	8-10
Safe Mode Recovery	8-14
Safe Mode (ERR-202-5)	8-15
USB Driver Troubleshooting	8-16
No Communications between Panel and PC (Personal Computer)	8-17
No Communications Between Panel and PC (Personal Computer) via USB	8-23
No Communications Between Panel and PC (Personal Computer) via Ethernet	8-25
No Communications between Panel and PLC	8-26
IP Address in System Setup Screens Displays 0.0.0.0.....	8-30
Difficulty Connecting to the Panel over the Internet (Web Server and Remote Access Features)	8-31
PLC Protocol Error Codes	8-32
HMI Runtime Errors	8-33
Panel Constantly Displays “Initializing” when Powering Up	8-34
Data Not Logging Problems	8-34
Electrical Noise Problems	8-35
Touch Screen Not Working	8-35
Chapter 9: Replacement Parts	9-1
Replacement Parts Overview	9-2
3-wire Communications Terminal Block – EA9-3TB	9-3
DC Power Connector Replacement – C0-4TB	9-3

Appendix A: Panel and PLC Error Code tables A-1

- Introduction.....A-2
- C-more* Touch Panel Error Code TableA-3
- Direct*LOGIC – Panel Error Code PLC-499 ExplanationA-5
- Direct*LOGIC K-Sequence Protocol - PLC Error Code TableA-5
- Direct*LOGIC DirectNET Protocol – PLC Error Codes.....A-5
- Modbus Protocols Error Code P499 ExplanationA-6
- Direct*LOGIC ECOM Protocol – PLC Error CodesA-7
- AutomationDirect Do-More Error CodesA-8
- Allen-Bradley – Panel Error Code PLC-499 Explanation.....A-9
- Allen-Bradley DF1 Protocol – PLC Error Code Tables.....A-10
- Allen-Bradley EtherNet/IP Protocol – Panel Error Code PLC-496, 497 and 498 ExplanationA-12
- Allen-Bradley – EtherNet/IP Protocol – PLC Error Code Tables ControlLogix, CompactLogix, & FlexLogixA-13
- Allen-Bradley – Micro800 Serial and EtherNet/IP Tag Based PLC Error Code TablesA-17
- Allen-Bradley – EtherNet/IP Protocol – PLC Error Code Tables.....A-21
- Generic EtherNet IP Protocol – PLC Error CodesA-25
- GE 90-30 – Panel Error Code PLC-499 ExplanationA-26
- GE 90-30 SNPX Protocol – PLC Error Code Tables.....A-27
- Mitsubishi FX Protocol – PLC Error CodesA-35
- Omron – Panel Error Code PLC-499 ExplanationA-35
- Omron Host Link Protocol – PLC Error Code Table.....A-36
- Omron FINS Protocol – PLC Error Code TableA-37
- Omron – Panel Error Code PLC-495 ExplanationA-39
- Omron CS/CJ FINS Ethernet Protocol – PLC Error Code Table.....A-40
- Siemens – Panel Error Code P499 Explanation.....A-41
- Siemens PPI Protocol – PLC Error Code Table.....A-42
- Siemens ISO over TCP Protocol – PLC Error Code TableA-43

Appendix B: Touch Panel Runtime Errors..... B-1

- Introduction..... B-2
- Runtime Errors..... B-3

Appendix C: System Screen Error Codek C-1

- C-more* Touch Panel System Screen Error Code Table.....C-2

Appendix D: Security Considerations for Control Systems Networks..... D-1

- Security Considerations for Control Systems Networks..... D-2

GETTING STARTED



CHAPTER

1

In This Chapter...

Introduction	1-2
The Purpose of This Manual.....	1-2
Supplemental Manuals.....	1-2
Technical Support	1-2
Conventions Used	1-3
Key Topics for Each Chapter	1-3
Product Overview	1-4
Quick Start Steps	1-5
Optional Accessories	1-5
C-more LED Status Indicators.....	1-11
CM5-RHMI Beep.....	1-12
Reset Button	1-12
RUN / STOP switch.....	1-12
User Defined LED	1-12

Introduction

The Purpose of This Manual

Thank you for purchasing our **C-more**® human-machine interface (HMI) family of products. This manual describes AutomationDirect.com's **C-more** headless HMI, its specifications, included components and available accessories and provides you with important information for installation, connectivity and setup. The manual shows you how to install, wire and use the product. It also helps you understand how to interface the HMI to other devices in a control system.

This user manual contains important information for personnel who will install the HMI and accessories and for the personnel who will be programming the HMI. If you understand control systems that make use of operating interfaces such as the **C-more** RHMI, our user manuals will provide all the information you need to get and keep your system up and running.

Supplemental Manuals

If you are familiar with industrial control type devices, you may be able to get up and running with just the aid of the Quick Start Guide that is available for download. You should also refer to the On-line help that is available in the **C-more** programming software for more information about programming the panel.

Technical Support

We strive to make our manuals the best in the industry. We rely on your feedback to let us know if we are reaching our goal. If you cannot find the solution to your particular application, or, if for any reason you need technical assistance, please call us at:

770-844-4200

Our technical support group will work with you to answer your questions. They are available Monday through Friday from 9:00 A.M. to 6:00 P.M. Eastern Time. We also encourage you to visit our web site where you can find technical and non-technical information about our products and our company.

<http://c-more.automationdirect.com>

Conventions Used



When you see the “notepad” icon in the left-hand margin, the paragraph to its immediate right will be a special note. The word **NOTE:** in boldface will mark the beginning of the text.



When you see the “exclamation mark” icon in the left-hand margin, the paragraph to its immediate right will be a warning. This information could prevent injury, loss of property, or even death (in extreme cases). The word **Warning:** will mark the beginning of the text.

Key Topics for Each Chapter

The beginning of each chapter will list the key topics that can be found in that chapter.

Getting Started	CHAPTER 1
In This Chapter...	
General Information	1-2
Specifications	1-4

Product Overview

Some of the features designed into the product to provide excellent hardware and software are listed below.

- HID touch screen driver works with most pCap and Resistive touchscreen monitors
- Plenty of memory and methods to get data in/out of the panel
- Overlapping active devices onscreen
- 16.7 million colors for enhanced graphics
- HDMI Video Output supporting several resolutions including 1080p (60Hz) and Audio
- Built-in FTP client/server, E-mail client, Web server, and MQTT Client
- User-configurable LED on the front of the unit
- Built-in project simulation; test on PC while developing
- Two Ethernet 10/100 Base-T ports
- 15-pin serial port with RS-232, RS422/485
- 3-wire terminal block RS-485 port
- Program via USB or Ethernet
- Object and bitmap animation
- Thousands of built-in symbols and Windows fonts
- PID face plate, trending, alarming, and a recipe database
- Trend Data Logging
- Event Manager to trigger actions based on assigned state changes, schedules, PLC tag names, set up in a database environment, trigger a sound byte, initiate a screen capture, send a data file (FTP), send an E-mail, etc.
- Internet Remote Access
- Network time server/client
- JPEG and JPG graphic object support (to reduce project size)
- 4 USB Type A ports for data logging, project transfer, audio adapter, mouse, and other HID compatible devices

Quick Start Steps

Step 1 – Unpack and Inspect

a.) Unpack the **C-more** RHMI from its shipping carton.



b.) Unpack any accessories that have been ordered, such as programming cable, communications cable, etc.

c.) Inspect all equipment for completeness. If anything is missing or damaged, immediately call the AutomationDirect® returns department @ 1-800-633-0405.

Optional Accessories

SD Memory Card
EA-SD-CARD



USB Pen Drive
USB-FLASH



DSUB Port Adapter
EA-COMCON-3A



Step 2 – Install Optional Hardware Accessories

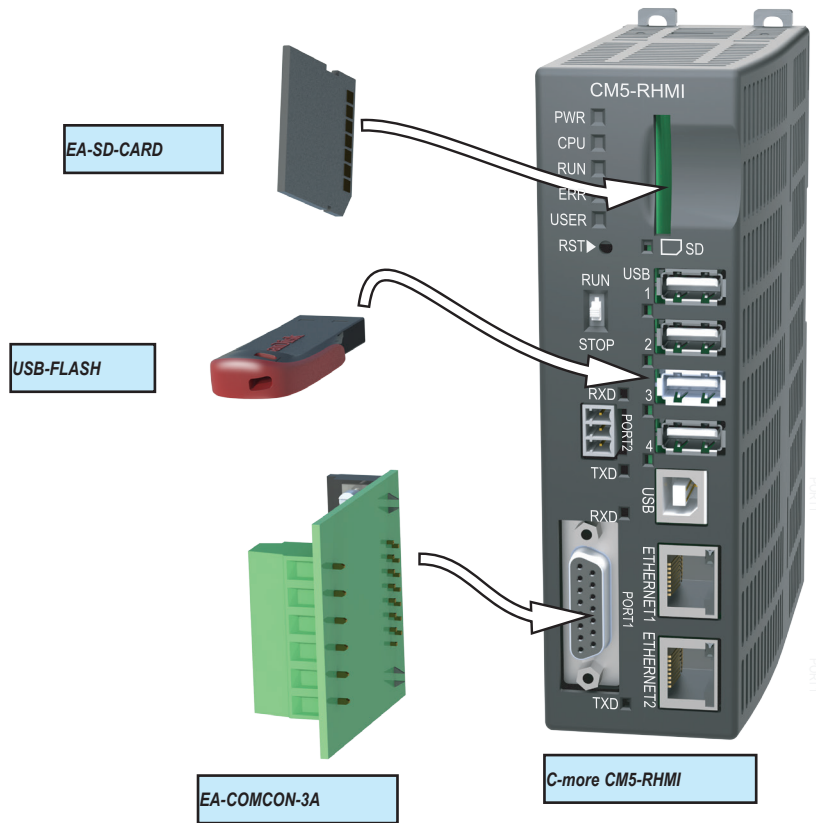

Step 3 – Become Familiar with Available Communication Ports

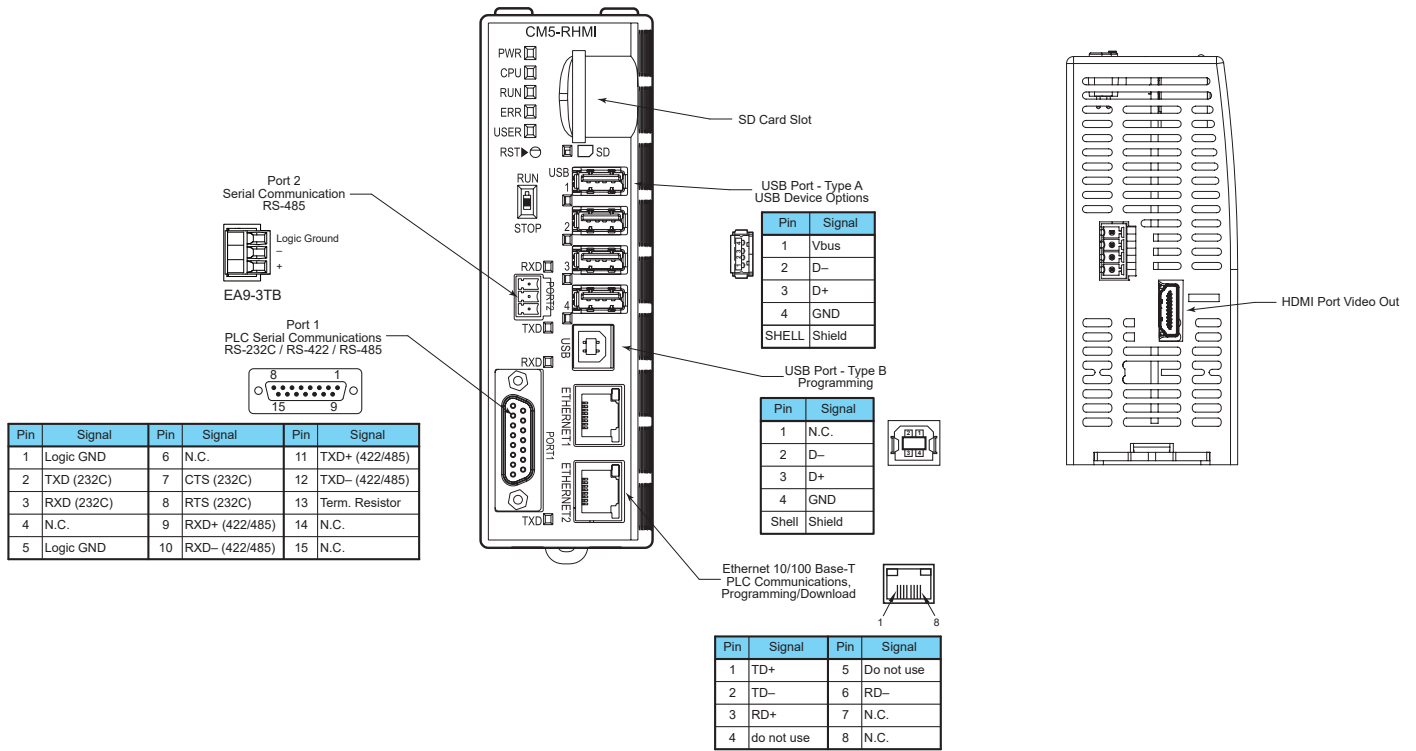

NOTE: See Chapter 6: PLC Communications for additional details on the available communication ports, protocols and cables.

Step 4 – Install the Programming Software and Develop a Project

Download the latest version of the **C-more** Programming Software, p/n CM5-PGMSW, from the Automationdirect website. Alternately, if the **C-more** Programming Software USB is available, you may install from the software USB. Refer to the AutomationDirect website for current minimum system requirements for installation.

For software download installation, follow the screen prompts to download and install the **C-more** Programming Software.

For USB installation, insert the supplied USB into the PC's USB port and navigate to the USB drive location on the PC. Double-click on *EA_Setup.exe* and follow the instructions. If you need assistance during the software installation, call the AutomationDirect Technical Support team @ 770-844-4200.



NOTES: Regarding Ethernet access to a C-more panel.

If you intend to take advantage of the methods of remote access to the panel, including the web server, PC remote access, FTP, iOS or Android app, you need to consider the security exposure in order to minimize the risks to your process and your C-more panel.

Security measures may include password protection, changing the ports exposed on your network, including a VPN in your network, and other methods. Security should always be carefully evaluated for each installation. Refer to Appendix C - Security Considerations for Control Systems Networks.

Step 5 – Connect HMI to Computer

- Connect a USB Programming Cable, such as p/n USB-CBL-AB15, from a USB type A port on the PC to the USB type B programming port on the **C-more** HMI.
- Or connect the **C-more** CM5-RHMI and PC together either directly or via an Ethernet switch and CAT5 Ethernet cables

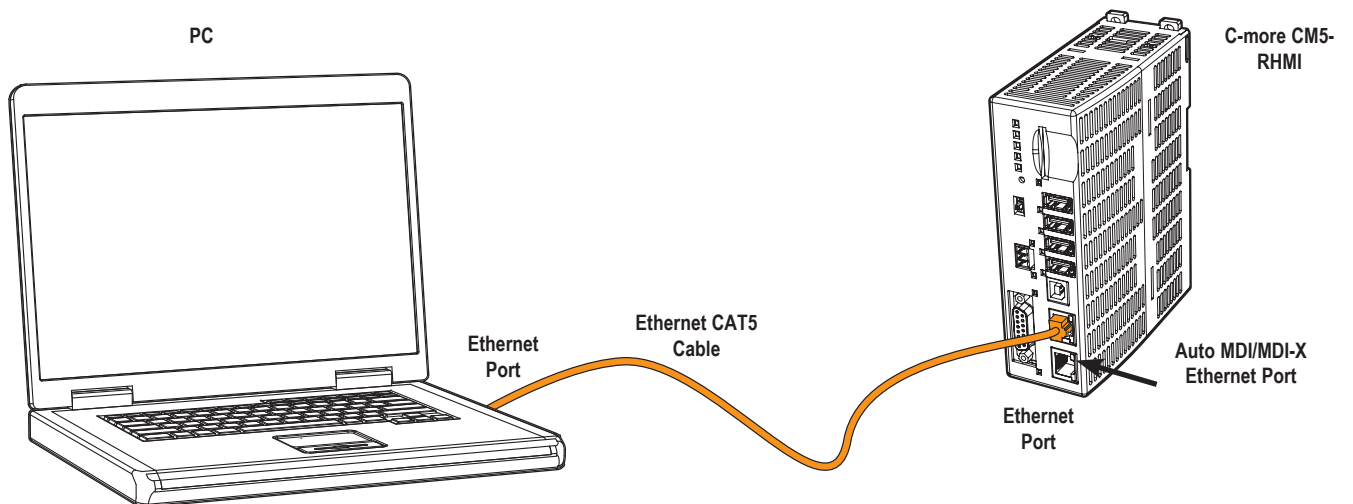
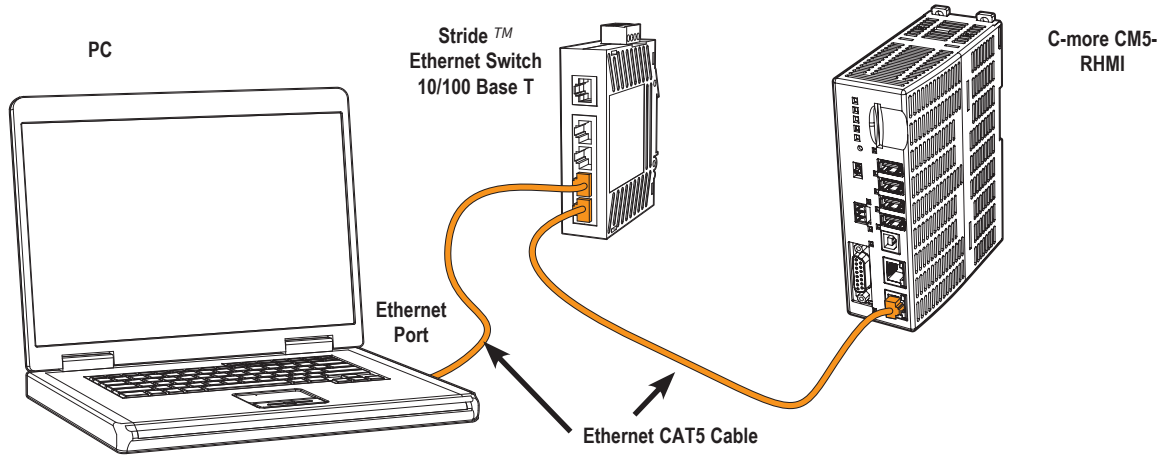
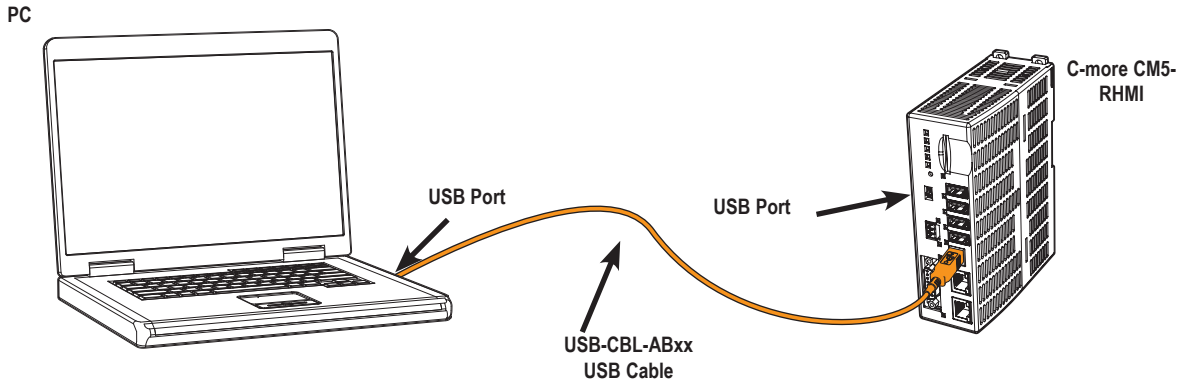

Step 6 – Provide Power to the HMI

- **Connect a dedicated** 12-24 VDC Class 2 power supply to the DC connector on the front of the **C-more** CM5-RHMI. Make sure to connect the ground terminal to a proper equipment ground.
- **Then** turn on the power source and check the LED status indicators on the front of the **C-more** CM5-RHMI for proper indication (see next page).



NOTE: A dedicated power supply is recommended. If the power supply also feeds inductive loads such as solenoids or relays, the transients caused by these loads can affect the operation of or cause damage to HMI components.

DC Power Wiring

Recommended Fuse	
Rating	ADC part number
5 A	MDL-5

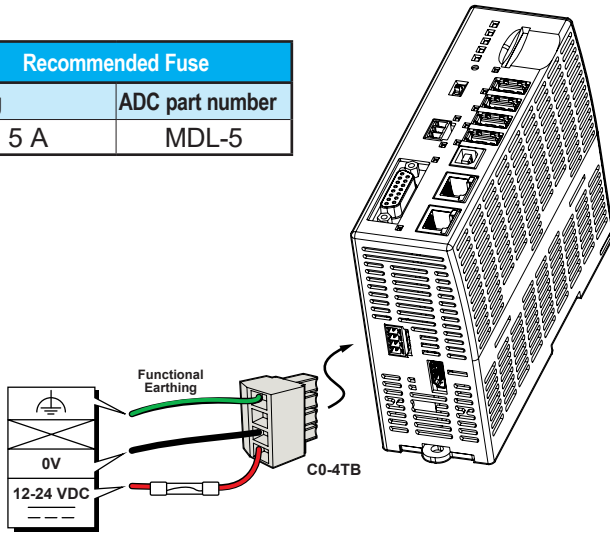

Tightening Torque	
Power supply cable torque	35 oz-in (0.25 Nm)



Warning: Use 60/75°C copper conductors only.

Step 6 – Provide Power to the HMI (cont'd)

C-more LED Status Indicators

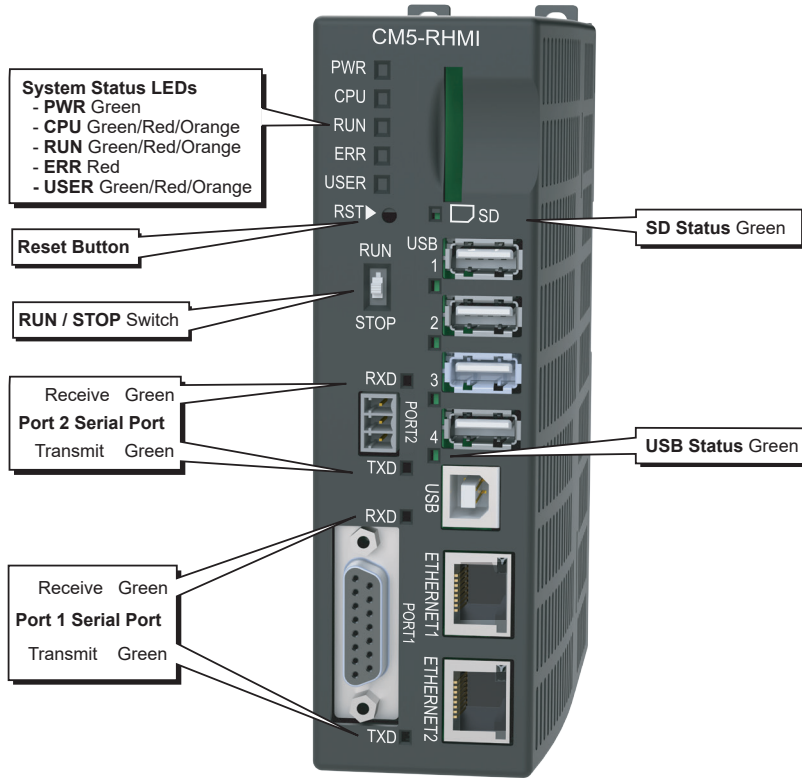

System Status LEDs				
	LED	CPU	RUN	ERR
State	Loading Project	–	Blinking Green (0.2s)	–
	Loading OS	Blinking Green (0.5s)	–	OFF
	CPU Running Normally	Green	–	OFF
	Project Loaded and Running	–	Green	–
	No User Project	–	Orange	–
	Reset to Factory Default	Blinking Green (0.5s)	Blinking Green (0.5s)	Blinking Red (0.5s)
	System Screen	–	OFF	–
	Password Required	–	Blinking Orange (0.5s)	Blinking Red (0.5s)
	Errors	Power Loss Detection	Blinking Orange (0.2s)	–
Memory Error		Red	OFF	Red
OS Error		Blinking Orange (0.5s)	OFF	Red
No Log Storage Found		–	Blinking Orange (0.5s)	Blinking Red (0.5s)
General Error*		–	Red	Blinking Red (0.5s)
Warning*		–	Blinking Orange (0.5s)	Blinking Red (0.5s)
Safe Mode		Orange	OFF	Red

*Note - See Chapter 8 – Troubleshooting for General Error and Warning explanations.

CM5-RHMI Beep

Beep Functions

Function	Beep Pattern
Boot	1-long, 2-short
Boot Error*	3-long
HDMI Connected	3-short
Reset to Factory Defaults	14 short beeps progressively closer together followed by 1-long beep.
Blink Screen	5-long
*Boot Errors Multiple Projects Write Protected SD Card No Log Storage Found Password Protected	

Reset Button

Reset Button

Push Action	Behavior	Note
Push for <15 seconds	Reboot the CM5-RHMI	
Push for >15 seconds	Reset to factory default	The project is cleared and all settings are initialized.
While holding down the reset button, power on the CM5-RHMI and continue holding the button for >15 seconds	Safe mode	The CPU LED will blink ORANGE. See “No System Found” in Chapter 8 - Troubleshooting

RUN / STOP switch

RUN / STOP Switch

Position	Behavior	Note
RUN	Project will run if present and the RUN LED will be green	If no project is loaded in the HMI, the message “No User Program” will be displayed on a connected display. The RUN LED will be orange.
STOP	The project and any logging stops and the System Screen is displayed.	If a password has been set up for the System Screen, the RUN LED will blink orange.
Power on the CM5-RHMI while in the STOP position	The System Screen is displayed	A System Screen password is ignored.

User Defined LED

The user defined LED on the CM5-RHMI can be controlled from the project to illuminate red, green or orange. It can also be configured to blink these colors. Refer to the online help file provided with the programming software for details.

Step 7 – Access the CM5-RHMI Setup Screens

- Access the Main Menu of the CM5-RHMI System Setup Screens by changing the selector switch on the front of the unit to STOP.
- Adjust the time and date for the panel by pressing the Setting button on the Main Menu. Then press the Adjust Clock button on the Setting screen.
- Use the right-pointing arrows for the time or date display to select the unit to change. Use the up and down arrows to increment or decrement the value for the selected unit.
- Press OK when done to accept the changes to the time and date in the HMI or press Cancel to exit the Adjust Clock setup screen without making any changes.
- Press the Main Menu button on the Setting screen and then the Exit button on the Main Menu screen to return to the application screen.
- Change the selector switch on the front of the unit to RUN.

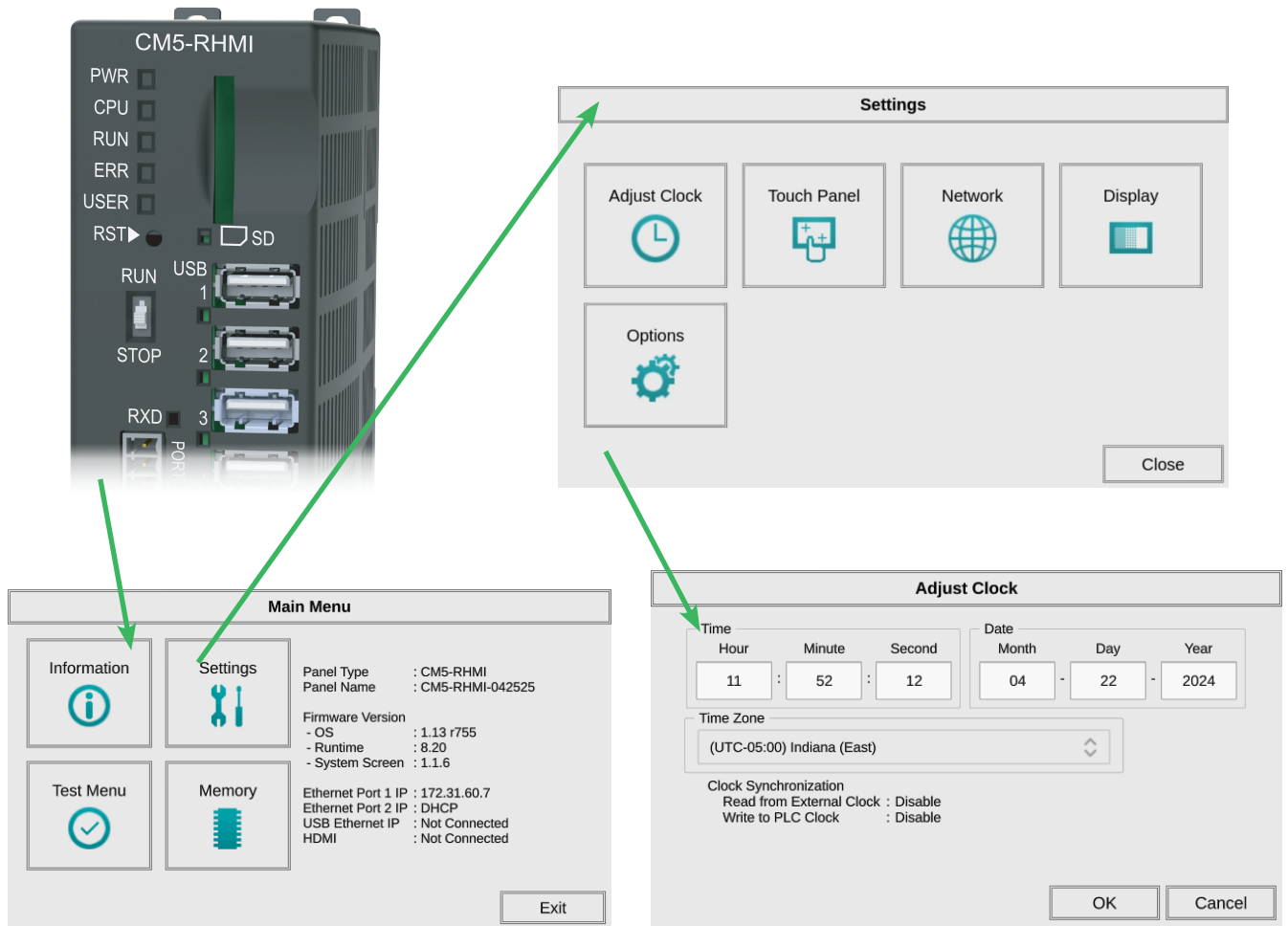

NOTE: For more information on CM5-RHMI setup screens, see Chapter 5 - System Setup Screens.

Step 8 – Choose HMI to Device Cable

The table below shows the PLCs, controllers and protocols supported by the CM5-RHMI. Ensure your controller and protocol are supported.

PLC Protocol Table

Model		Protocols	
AutomationDirect	Productivity Series		
		Productivity Serial Productivity Ethernet	
	Do-more (BRX)	All	Do-more Serial Do-more Ethernet
	CLICK	All	CLICK Serial
		C0-1x series	CLICK Ethernet
	CLICK PLUS	C2-01CPU-x, C2-03CPU-x, All with C2-DCM	CLICK Serial
		All	CLICK Ethernet
	DL05/DL06	all	K-Sequence
			<i>Direct</i> NET
			Modbus (Koyo addressing)
		H0-ECOM/H0-ECOM100	<i>Direct</i> LOGIC Ethernet
	DL105	all	K-Sequence
	DL205	D2-230	K-Sequence
		D2-240	K-Sequence <i>Direct</i> NET
		D2-250/D2-250-1/D2-260/D2-262	K-Sequence
			<i>Direct</i> NET
			Modbus (Koyo addressing)
		D2-240/D2-250-1/D2-260 Using DCM	<i>Direct</i> NET Modbus (Koyo addressing)
		H2-ECOM/H2-ECOM100	<i>Direct</i> LOGIC Ethernet
	DL305	D3-330/330P (Requires the use of a Data Communications Unit)	
		D3-340	<i>Direct</i> NET
		D3-350	K-Sequence
			<i>Direct</i> NET
			Modbus (Koyo addressing)
		D3-350 DCM	<i>Direct</i> NET Modbus (Koyo addressing)
	DL405	D4-430	K-Sequence <i>Direct</i> NET
		D4-440	K-Sequence <i>Direct</i> NET
D4-450/D4-454		K-Sequence	
		<i>Direct</i> NET	
		Modbus (Koyo addressing)	
All with DCM		<i>Direct</i> NET Modbus (Koyo addressing)	
H4-ECOM/H4-ECOM100		<i>Direct</i> LOGIC Ethernet	
H2-WinPLC (Think & Do) Live V5.2 or later and Studio any version		Think & Do Modbus RTU (serial port)	
H2-WinPLC (Think & Do) Live V5.5.1 or later and Studio V7.2.1 or later		Think & Do Modbus TCP/IP (Ethernet port)	
GS Drives		GS Drives Serial	
		GS Drives TCP/IP (GS-EDRV)	
SOLO Temperature Controllers (models with serial communications)		SOLO Temperature Controller	

Step 8 – Choose HMI to Device Cable (cont'd)

PLC Protocol Table (cont'd)		
Model		Protocols
	MicroLogix 1000, 1100, 1200, 1400 and 1500	DF1 Half Duplex; DF1 Full Duplex
	SLC 5-03/04/05	
	ControlLogix™, CompactLogix™, FlexLogix™	DF1 Full Duplex
	PLC-5	
	ControlLogix, CompactLogix, FlexLogix - Tag Based	DF1 Half Duplex; DF1 Full Duplex
	ControlLogix, CompactLogix, FlexLogix - Generic I/O Messaging	EtherNet/IP Server
	ControlLogix, CompactLogix, FlexLogix - Tag Based	EtherNet/IP Client
	MicroLogix 1100, 1400 and SLC 5/05, via native Ethernet port	
	MicroLogix 1000, 1100, 1200, 1400, 1500, SLC 5-03/04/05, all via ENI adapter	
	Micro 800 Series	Modbus RTU
Modbus TCP		
Micro 800 Series - Tag Based	DF1 Full Duplex	
	EtherNet/IP Client	
Modbus RTU	Modbus RTU devices	Modbus RTU
Modbus TCP/IP	Modbus TCP/IP devices	Modbus TCP/IP
GE	90/30, 90/70, Micro 90, VersaMax Micro	SNPX
	90/30, Rx3i	S RTP Ethernet
Mitsubishi	FX Series	FX Direct
	Q02, Q02H, Q06H, Q12H, Q25H	Q CPU
	Q, QnA Serial	QnA Serial
	Q, QnA Ethernet	QnA Ethernet
Modicon	984 CPU, Quantum 113 CPU, AEG Modicon Micro Series 110 CPU: 311-xx, 411-xx, 512-xx, 612-xx	Modbus RTU
	Other devices using Modicon Modbus addressing	Modbus RTU TUModbus TCP/IP
Omron	C200 Adapter, C500	Host Link
	CJ1/CS1 Serial	FINS
	CJ1/CS1 Ethernet	
Siemens	S7-200 CPU, RS-485 Serial	PPI
	S7-200 CPU, S7-300 CPU, S7-400, S7-1200 CPU Ethernet	Ethernet ISO over TCP

Step 9 – Connect HMI to PLC

- Connect the serial communications cable between the **C-more** CM5-RHMI and the PLC
- **Or** connect the **C-more** CM5-RHMI and PLC together either directly or via an Ethernet switch and CAT5 Ethernet cables.

For further information on setting up communications between the CM5-RHMI and a PLC, see the **C-more** programming help file topic *CM129: Creating a New Project*.

Cable Description	Cable Part Number
Communication cable, 15-pin D-shell male to 6-pin RJ12, 9.8ft/3m cable length. For use with C-more or C-more Micro panel and AutomationDirect PLCs with RJ12 ports.	EA-2CBL
Communication cable, 15-pin D-shell male to 15-pin D-sub HD15 male, 3m/9.8ft cable length. For use with C-more or C-more Micro panel and a DL06, D2-250(-1), D2-260 or D2-262 (bottom port) CPU.	EA-2CBL-1
Communication cable, 15-pin D-shell male to 6-pin RJ11, 3m/9.8ft cable length. For use with C-more or C-more Micro panel and a D3-340 CPU top or bottom port.	EA-3CBL
Communication cable, 15-pin D-shell male to 15-pin D-shell male, 3m/9.8ft cable length. For use with C-more or C-more Micro panel and a DL405 (top port) CPU.	EA-4CBL-1
Communication cable, 15-pin D-shell male to 25-pin D-shell male, 3m/9.8ft cable length. For use with C-more or C-more Micro panel and a D2-DCM, D3-232-DCU, D3-350 (bottom port) or DL405 (bottom port) CPU.	EA-4CBL-2
Communication cable, 15-pin D-shell male to 8-pin mini DIN male, 3m/9.8ft cable length. For use with C-more or C-more Micro panel and an Allen-Bradley Micrologix CPU.	EA-MLOGIX-CBL
Communication cable, 15-pin D-shell male to 9-pin D-shell female, 3m/9.8ft cable length. For use with C-more or C-more Micro panel and an Allen-Bradley SLC 5/03, 5/04 or 5/05 CPU with DF-1 port.	EA-SLC-232-CBL
Communication cable, 15-pin D-shell male to 25-pin D-shell male, 3m/9.8ft cable length. For use with C-more or C-more Micro panel and an Allen-Bradley PLC-5 CPU with a DF1 port.	EA-PLC5-232-CBL
Communication cable, 15-pin D-shell male to 15-pin D-shell male, 3m/9.8ft cable length. For use with C-more or C-more Micro and GE Fanuc Series 90/30 or 90/70 serial port.	EA-90-30-CBL
Communication cable, 15-pin D-shell male to 25-pin D-shell male, 3m/9.8ft cable length. For use with C-more or C-more Micro panel and a Mitsubishi FX Series CPU.	EA-MITSU-CBL
Communication cable, 15-pin D-shell male to 8-pin mini DIN male, 3m/9.8ft cable length. For use with C-more or C-more Micro panel and a Mitsubishi FX Series CPU.	EA-MITSU-CBL-1
Communication cable, 15-pin D-shell male to 25-pin D-shell male, 3m/9.8ft cable length. For use with C-more or C-more Micro panel and an Omron C200 or C500 CPU.	EA-OMRON-CBL



NOTE: The above list of pre-made communications cables may be purchased. See Chapter 6: PLC Communications for wiring diagrams of additional user constructed cables. Chapter 6 also includes wiring diagrams for the pre-made cables.

EA-2CBL

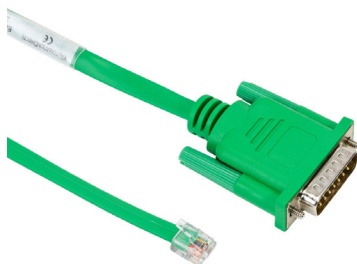

EA-2CBL-1

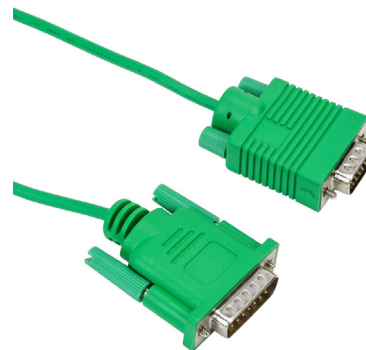

Serial

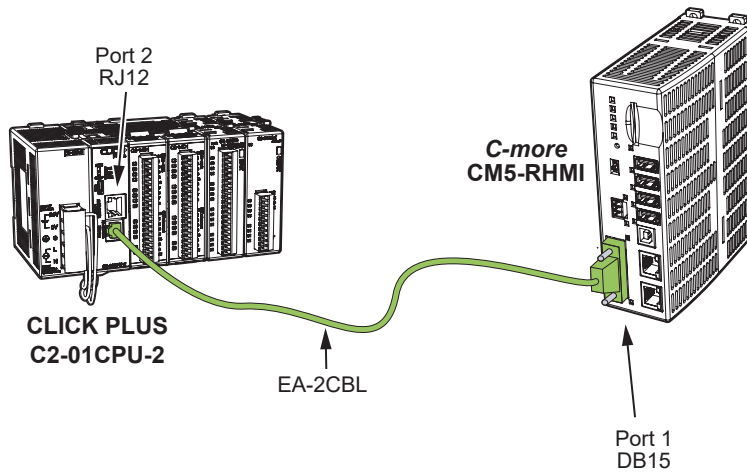

Ethernet via Switch

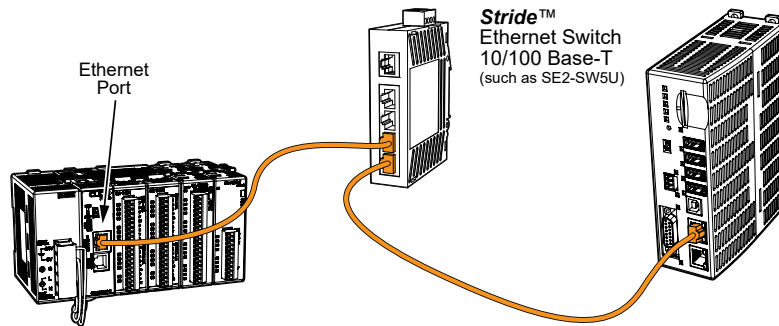

Ethernet

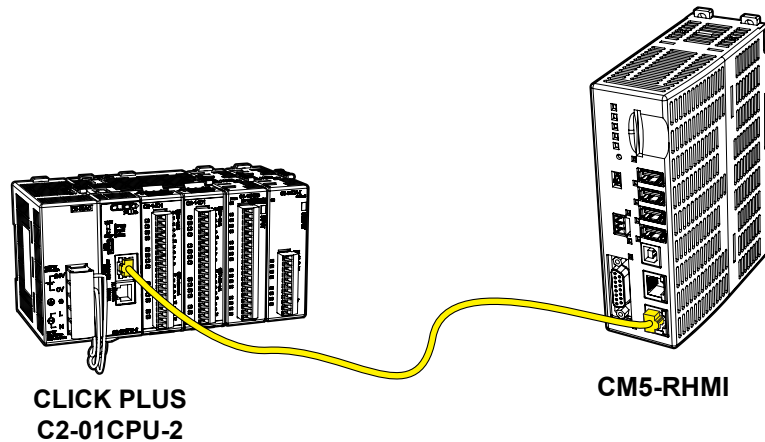

BLANK
PAGE

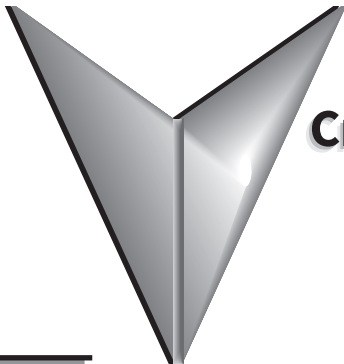

CHAPTER

2

SPECIFICATIONS

In This Chapter...

Specifications	2-2
Dimensions.....	2-4
Communication Ports and Memory Expansion	2-5
HDMI Port Video Out.....	2-5
Communication Ports	2-6
Ethernet Port.....	2-6
USB Type B Port.....	2-6
USB Type A Port.....	2-7
Serial Communication Ports	2-7
Port 1	2-7
Port 2	2-8
User Defined LED.....	2-8
Compatible Touch Screen Monitors.....	2-9
Handling External Memory Devices	2-10
Writing to External Memory devices	2-10
Memory Device Formatting.....	2-10
Minimizing Data Errors.....	2-11
Monitoring Available Memory.....	2-12
Power Loss Retention.....	2-12
Watchdog Timeout.....	2-13
Overview.....	2-13

Specifications

The **C-more®** RHMI Operator Interface is the next generation of HMI brought to you by AutomationDirect. It has been designed to display and interchange graphical data from a PLC by connecting a monitor and USB mouse or compatible touch screen or accessing screens remotely from a PC or smart device app.

CM5-RHMI Specifications	
Operating Temperature	0 to 50°C (32 to 122°F) Maximum surrounding air temperature rating: 50°C (122°F) IEC 60068-2-14 (Test Nb, Thermal Shock)
Altitude	Up to 2000m (6562ft)
Storage Temperature	-20 to +60°C (-4 to +140°F) IEC 60068-2-1 (Test Ab, Cold) IEC 60068-2-2 (Test Bb, Dry Heat) IEC 60068-2-14 (Test Na, Thermal Shock)
Humidity	5–95% RH (non-condensing)
Environment	For use in Pollution Degree 2 environment, no corrosive gases permitted
Noise Immunity	(EN61131-2) EN61000-4-2 (ESD): 2kV/4kV (Contact Discharge) 2kV/4kV/8kV (Air Discharge) EN61000-4-3 (RFI): 10V/m (80MHz-1GHz), 3V/m (1.4GHz-2.0GHz) 1V/m (2.0GHz-2.7GHz) EN61000-4-4 (FTB): 2kV, positive/negative, 5kHz (DC power port) EN61000-4-5 (Surge): 0.5kV/1kV line to line 0.5kV/2kV line to earth EN61000-4-6 (Conducted): 10V, 0.15–80MHz EN61000-4-8 (Power frequency magnetic field immunity): 30A/m (Local test) RFI, (145MHz, 440MHz 10W @10cm) Impulse 1000V @ 1µs pulse
Withstand Voltage	1000VAC, 1 min. (FG to power supply)
Insulation Resistance	> 10M ohm @ 500VDC (FG to power supply)
Vibration	IEC60068-2-6 (Test Fc) 5-9Hz: 3.5 mm amplitude, 9-150Hz 1.0G 10 sweep cycles per axis on each of 3 mutually perpendicular axes
Shock	IEC60068-2-27 (Test Ea) 15G peak, 11ms duration, 3 shocks in each direction per axis, on 3 mutually perpendicular axes
Specifications continued on next page	



NOTE: The touch screen driver is designed to respond to a single touch. If it is touched at multiple points at the same time, an unexpected object may be activated.

Specifications (cont'd)

CM5-RHMI Specifications (continued)	
Emission	EN55011 Class A (Radiated RF emission)
Supply Power	10.2-26.4 VDC Class2 or SELV (Safety Extra-Low Voltage) Circuit or Limited Energy Circuit (LEC), Reverse Polarity Protected
Weight	1.06 lb (480g)
Color Scale	16.7 million colors
Project Memory	90MB
Number of Screens	Up to 999 screens – limited by project memory
Realtime Clock	Realtime Clock built into unit, backed up for 30 days at 25°C after power has been applied for 24 hours
Calendar - Month / Day / Year	Yes - monthly deviation 60 sec at 25°C
Serial Port 1	15-pin D-sub – RS-232, RS-422/485
Serial Port 2	3-wire terminal block – RS-485
USB Port - Type B	USB 2.0 High speed (480 Mbps) Type B – Download/Program Max cable length - 15 ft.
USB Port - Type A	USB 2.0 High speed (480 Mbps) Type A – for USB device options Max cable length – 15ft Bus Power – Less than 500mA at 5VDC
Supported Touch Screen	HID touch screen driver works with most pCap and Resistive touchscreen monitors
Ethernet Ports	Ethernet Ports 10/100 Base-T, auto MDI/MDI-X
SD Card Slot	1 slot. Supports max 2GB (SD,) Max.2TB (SDXC)
HDMI Video Out	HDMI Type A Port
Power Consumption	18.0 W 1.5 A @ 12VDC 0.75 A @ 24VDC
Maximum Inrush Current	4.0 A @ 9.5 ms
Recommended Fuse	5 A (part no. MDL-5)
Internal Fuse (non-replaceable)	12 A
Agency Approvals	UL61010 (E157382), CE (EN61131-2), cUL Canadian C22.2, RoHS (2011/65/EU)

Dimensions

Inches [mm]

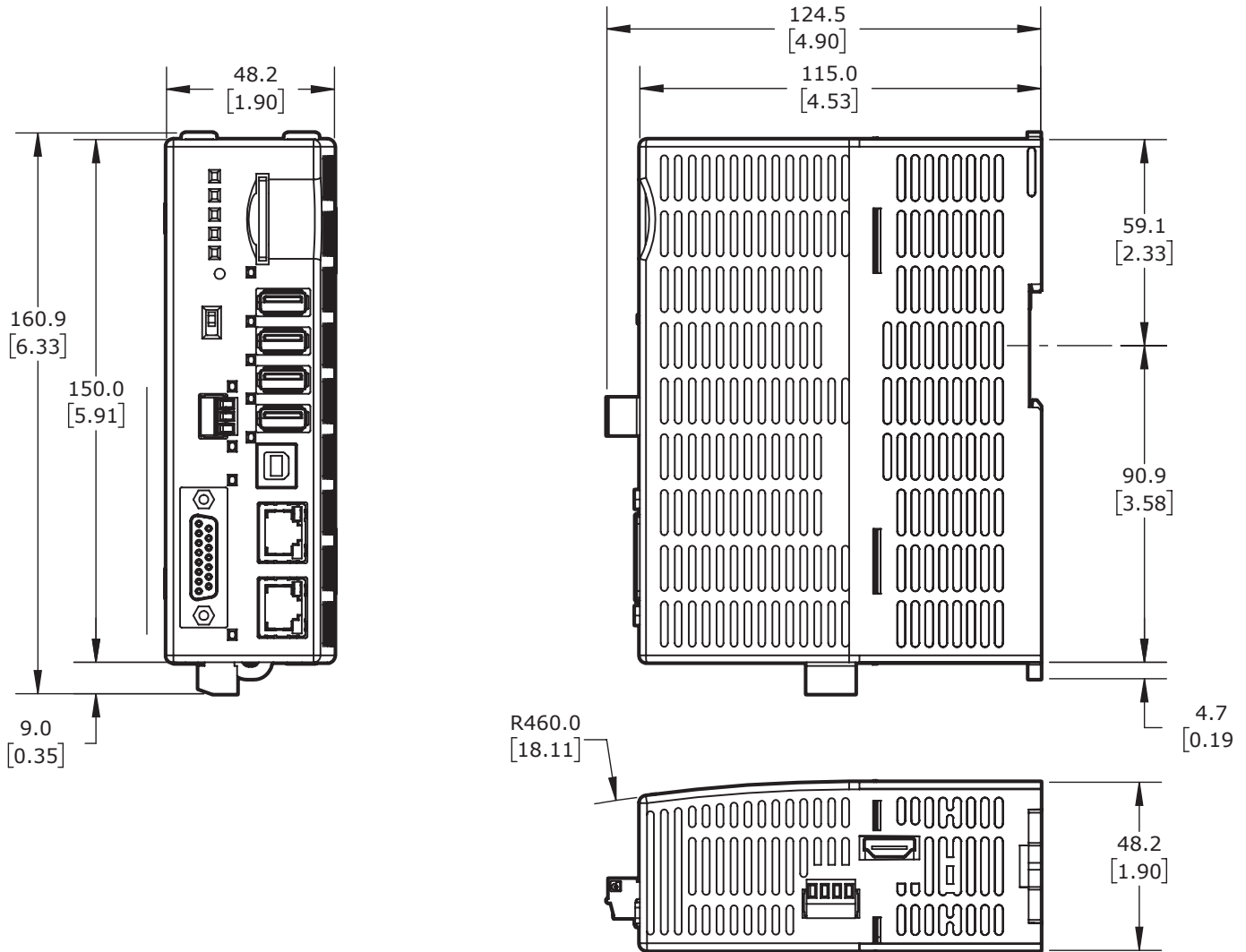

Communication Ports and Memory Expansion

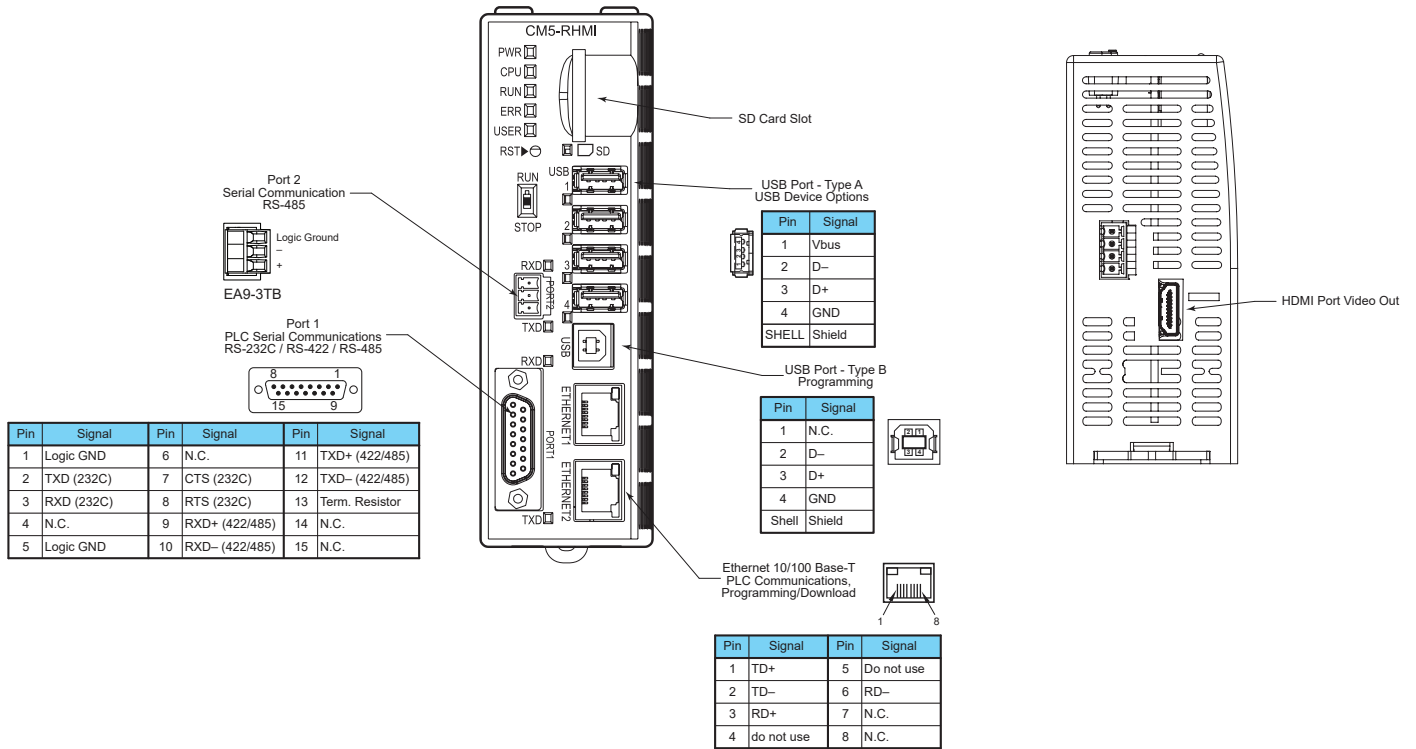

HDMI Port Video Out

CM5-RHMI Video Out Specifications	
Resolution	SD – 720 x 480 HD – 1280 x 720 VGA – 640 x 480 XGA – 1024 x 768 FHD – 1080 x 1290
Output	Video Data - Same Screen as Panel
Sound Pass Through	Does not support Mic sound Pass Through

Communication Ports

Ethernet Port

Either Ethernet port can be used several ways: for programming the panel (downloading a project), for PLC communication, and for the advanced features, such as sending e-mail, web server, FTP access, and allowing users to access and control the panel remotely.

The Ethernet connector is an RJ-45 Module jack.

Ethernet 10/100 Base-T
PLC Communications,
Programming/Download

Pin	Signal	Pin	Signal
1	TD+	5	do not use
2	TD-	6	RD-
3	RD+	7	N.C.
4	do not use	8	N.C.

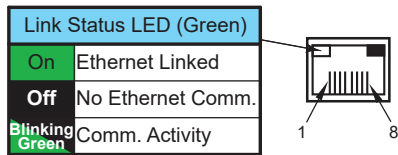

See AutomationDirect.com for the latest driver information.

USB Type B Port

Program **C-more** via the USB programming port. It's fast and easy, with no baud rate settings, parity, or stop bits to worry about. We stock standard USB cables for your convenience, such as part no.

USB Port - Type B
Programming

Pin	Signal
1	N.C.
2	D-
3	D+
4	GND
Shell	Shield

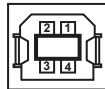

USB-CBL-AB15. The USB type B port can be used to upload or download projects to and from a PC (personal computer).

USB Type A Port

The USB type A port is a standard feature for all models and can be used to connect various USB 2.0 HID (Human Input Device) devices to the panel, such as:

- Industrial Monitor with a compatible touch screen or Mouse
- USB pen drives, (ADC p/n USB-FLASH)
- USB keyboards
- USB barcode scanners
- USB card scanners

C-more can log data to the USB pen drive as well as restore projects to the panel from the pen drive. You can also back up project files and panel firmware.

USB Port - Type A
USB Device Options

Pin	Signal
1	Vbus
2	D-
3	D+
4	GND
SHELL	Shield



NOTE: Output current is less than 500mA @ 5VDC.

Serial Communication Ports

Port 1

Connect to your serial controller network via Port 1. Port 1 is a 15-pin port that supports RS-232 and RS-422/485.

Port 1
PLC Serial Communications
RS-232C / RS-422 / RS-485

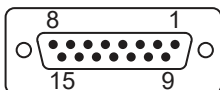

Pin	Signal	Pin	Signal	Pin	Signal
1	Logic GND	6	N.C.	11	TXD+ (422/485)
2	TXD (232C)	7	CTS (232C)	12	TXD- (422/485)
3	RXD (232C)	8	RTS (232C)	13	Term. Resistor
4	Do Not Connect	9	RXD+ (422/485)	14	N.C.
5	Logic GND	10	RXD- (422/485)	15	N.C.

Port 2

Connect your RS-485 network via Port 2. Port 2 is provided with a 3-wire removable terminal block.

Port 2
Serial Communication
RS-485

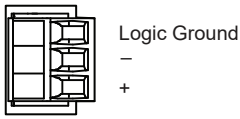

User Defined LED

The user defined LED on the panel front bezel can be controlled from the project to illuminate red, green or orange. It can also be configured to blink these colors. Refer to the online help file provided with the programming software for details.

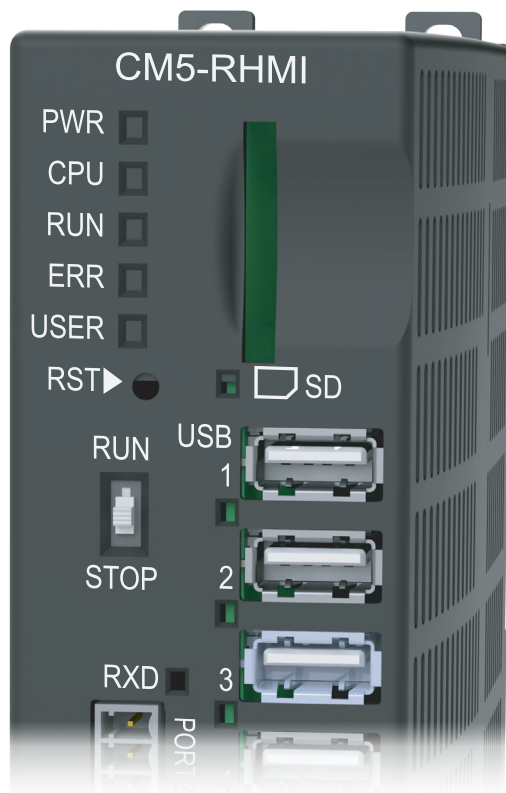

Compatible Touch Screen Monitors

The **C-more** CM5-RHMI supports most HID compatible Resistive and pCap touchscreens.

The manufacturers and models that have been tested at the time of firmware version 8.20 release are:

Please contact the touch screen monitor supplier to confirm it uses a supported driver.

CM5-RHMI Compatible Touch Screen Monitors		
Manufacturer / Distributor	Models	Touchscreen Type
Adlink	OM-215	pCap
Advantech	FPM-221W	pCap
Advantech	IDS-3215	Resistive
Atlas	ATM1500T	Resistive
Atlas	ATM1700T	Resistive
Atlas	ATM1900T	Resistive
Dynics	FX15PTUMAD	Resistive
ELO	E382790	SAW
ELO	ET1593L	pCap
Hope	HIS-ML15CTBH	Resistive
Hope	HIS-ML19.5CTBA	Resistive
Hope	HIS-ML19.5FPVB	pCap
Hope	HIS-ML19CTBH	Resistive
Hope	HIS-ML23-CTBD	pCap
HP	E24T G5	pCap
TruVu	VMTR-15C	Resistive
TruVu	ZBMT-18.5R	Resistive
ViewSonic	TD2465	pCap



NOTE: The USB standard requires all powered USB devices to prevent power from feeding back through the USB ports to connected devices. If a powered USB Hub, Bar Code Reader, or other powered device does not follow this standard, power may feed back into the CM5-RHMI USB A-port and cause the CM5-RHMI to remain powered on and operational even though power is removed from the CM5-RHMI.

One example is a touchscreen monitor with a built-in USB Hub. The USB-A port on the monitor may feed power back to the CM5-RHMI if the manufacturer did not follow the USB standard.

To protect against this event, make sure the power to the connected device and the CM5-RHMI are both powered down. Another alternative is to use an USB Power Blocker.

Handling External Memory Devices

Writing to External Memory devices

Different types of numeric and text data from the **C-more** touch panel can be stored on an SD card or a USB memory device. Numeric data from Line Trend Graph and PID Faceplate Trend Graph objects may be stored. Text data from Lookup Text and Multi-state Text Indicator objects can also be stored.

Up to 16 Line Trend or PID Trend objects may be configured in the **C-more** programming software to log data. Along with the 16 object limit, available storage on the external memory device is subject to the memory capacity of the SD card or USB memory device. One log file is created in a 24 hour period for each object. Additionally logging data is initially stored in the buffer in the panel SRAM and data is written to the external memory device:

- When 2kB of data is cached,
- When 20 records have been stored,
- Periodically, once every 1 minute,
- When one of the “SYS Copy LogTo %device%” or “SYS %device% Eject” tags is turned on.
- When there is an email or FTP action
- When the System Screen is called
- When the panel date is changed

Memory Device Formatting

Memory Devices should be formatted according to the following guidelines to insure best performance and integrity of logged data.

Item		Capacity	Supported Resolution	Supported
USB Memory Device		up to 2GB	FAT	Yes
		4GB to 32GB	FAT 32	Yes
		64GB or larger	exFAT	Yes
SD Card	Type			
	SD	up to 2GB	FAT	Yes
	SDHC	4GB to 32GB	FAT 32	Yes
	SDXC	32GB or larger	exFAT	Yes

SD cards must be formatted using the SD formatter provided by the SD Association at www.sdcard.org using the standard allocation unit size for best performance.

Minimizing Data Errors

To minimize data errors when logging data to external memory, consider the following:

- Do not turn off power to the **C-more** touch panel while the external memory device is being accessed.
- Do not remove any external memory device with the device is being accessed by the **C-more** panel.

The following internal tags should be used to monitor, access and safely remove external memory devices:

SYS SD1 WriteStatus	SYS Copy LogToUSB2	SYS USB4 Eject
SYS USB1 WriteStatus	SYS Copy LogToUSB3	SYS SD1 ReadyToUse
SYS USB2 WriteStatus	SYS Copy LogToUSB4	SYS USB1 ReadyToUse
SYS USB3 WriteStatus	SYS SD1 Eject	SYS USB2 ReadyToUse
SYS USB4 WriteStatus	SYS USB1 Eject	SYS USB3 ReadyToUse
SYS Copy LogToSD1	SYS USB2 Eject	SYS USB4 ReadyToUse
SYS Copy LogToUSB1	SYS USB3 Eject	

- Be sure to backup the memory device at regular intervals.
- If you suspect the memory device is bad, you may want to use a PC to re-format the device, or use a known good memory device.
- The number of times the memory device can be written to is limited. Consequently, logging frequently will may shorten the service life of the memory device. Using slower sample rates will increase the life of the device.

Monitoring Available Memory

Each external memory device can be monitored and events can be configured to alert the user when available memory is approaching the maximum capacity of the external memory device. The following internal tags allow external memory devices data to be monitored:

SYS SD1 TotalMemory	SYS USB1 UsedMemory	SYS USB3 FreeMemory
SYS SD1 FreeMemory	SYS USB2 TotalMemory	SYS USB3 UsedMemory
SYS SD1 UsedMemory	SYS USB2 FreeMemory	SYS USB4 TotalMemory
SYS USB1 TotalMemory	SYS USB2 UsedMemory	SYS USB4 FreeMemory
SYS USB1 FreeMemory	SYS USB3 TotalMemory	SYS USB4 UsedMemory

Refer to the **C-more** programming software online help files for additional information on system tags and managing data logging devices.

Power Loss Retention

When a power loss is detected, the panel will attempt to complete all data logging operations safely.

The power retention while using a DC power is not long enough to complete writes to an SD Card or USB device. An Uninterruptable Power Supply (UPS) should be considered.

Power Loss Detection (at 25°C)		
Power Supply	Detect Loss	Resume Operation
DC (Panel Only)	8.3 VDC	9.4VDC

Watchdog Timeout

Overview

The watchdog timer operates after product startup. Therefore, it will not operate in the event of a catastrophic hardware failure or if the CM5-RHMI fails to boot.

When Watchdog timeout occurs, the CM5-RHMI automatically reboots as part of the recovery process.

In this case, the Watchdog timer is processed with the highest priority, so other functions are inoperable.

CM5-RHMI Compatible Touch Screen Monitors			
Timing	CM5-RHMI Status	Supported Functions	Processing
At Startup	Hardware failure(*1)	Status LED control	OS Error, Memory Error
At Startup	Software startup failure(*2)	Software recovery	Shift to Safe Mode and manual Firmware Update
During operation	System runaway	Watchdog timeout	Automatic restart
During operation	Project froze(*3)	—	Restart by Power ON/OFF

(*1) If a hardware failure is suspected, check the status LED indications.

(*2) If there is a software error and the product fails to start, the CM5 will automatically reboot and enter Safe Mode. The user should update the product to the latest version firmware with the **C-more** Software.

(*3) If for some unforeseen reason the product freezes during operation, the user should cycle the power.

BLANK
PAGE

ACCESSORIES



CHAPTER

3

In This Chapter...

Accessories Overview	3-2
D-SUB 15-pin to Terminal Block Adapter	3-3
EA-COMCON-3A	3-3
SD Card	3-4
EA-SD-CARD	3-4
USB FLASH Drive	3-4
USB-FLASH	3-4

Accessories Overview

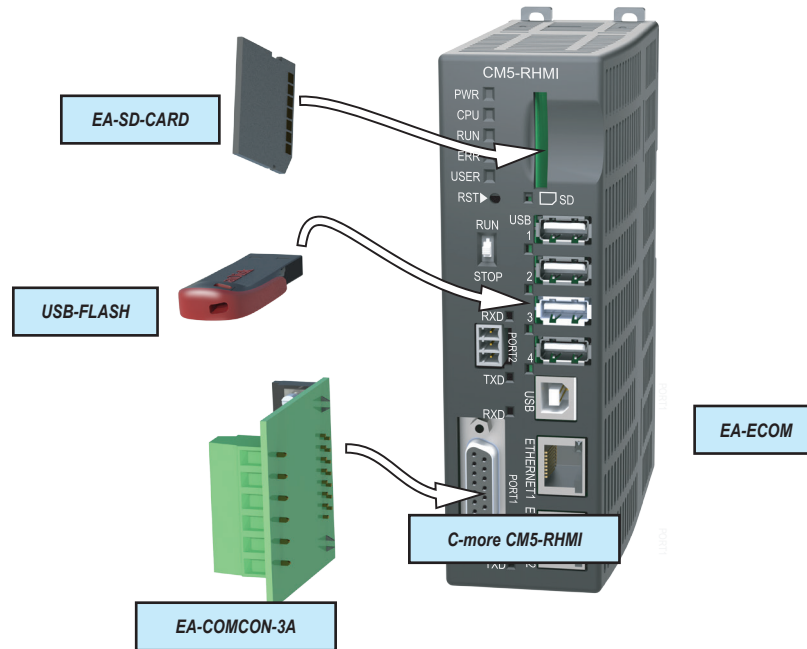

Part Number	Description
EA-SD-CARD	SD memory card for non-volatile storage, 2GB industrial grade. 85°C maximum operating temperature makes it suitable for data logging in industrial applications.
USB-FLASH	USB Flash drive, SanDisk, 32GB
EA-COMCON-3A	DSUB port adapter, 15-pin male to 6-pole RS-422/485 terminal block, straight cable entry

D-SUB 15-pin to Terminal Block Adapter

The EA-COMCON-3A adapter is plugged into the 15-pin serial port on the front of the CM5-RHMI to allow wire terminal connections for RS-422/485 PLC communication cables.

EA-COMCON-3A is NOT UL Recognized or Listed.

EA-COMCON-3A

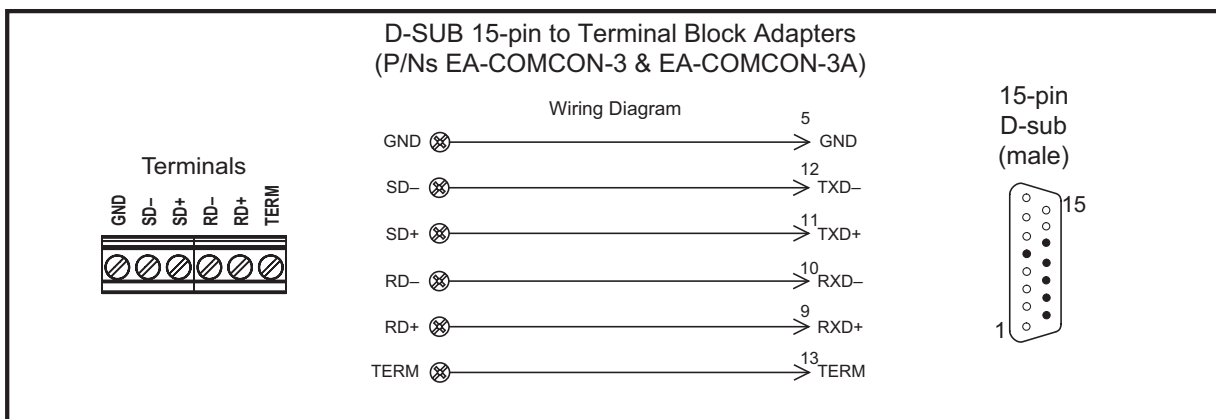
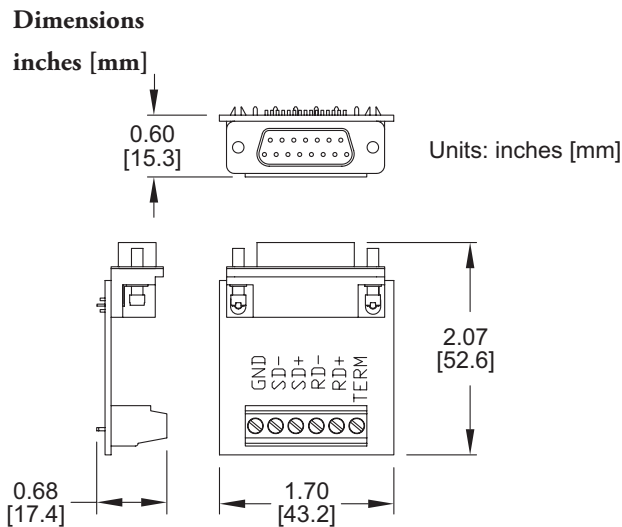

SD Card

SD memory card for non-volatile storage, 2GB industrial grade. 85° C maximum operating temperature makes it suitable for data logging in industrial applications. Recommended for **C-more** CM5 series. The EA-SD-CARD utilizes SLC technology so it is the fastest option for writing and storing data. If logged data is saved to external memory, AutomationDirect recommends using an EA-SD-CARD.

EA-SD-CARD

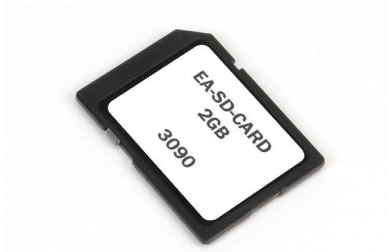

NOTE: SLC Flash memory utilized by EA-SD-CARD has the advantage of being the most accurate flash memory type when reading and writing data. SLC flash has the longest lifespan of flash types and can operate in a broader temperature range than other types.

EA-SD-CARD with SLC Flash memory is recommended for industrial workloads that require heavy read/write cycles.

USB FLASH Drive

USB-FLASH sold by AutomationDirect has been tested with **C-more** HMIs and is Hi-Speed USB 2.0 certified. The EA-SD-CARD is the best option for logging data, but the USB-FLASH is a high quality flash drive perfect for transferring log files, capturing screens, backing up and restoring projects and storing images for the Image Viewer object.

USB-FLASH





INSTALLATION AND WIRING

CHAPTER

4

In This Chapter...

Safety Guidelines	4-2
Plan for Safety.....	4-2
Introduction	4-3
Mounting	4-4
DIN Rail Mounting.....	4-4
Panel Mounting.....	4-4
Mounting Clearances.....	4-5
Wiring Guidelines	4-6
Agency Approvals.....	4-6
Providing Power to the HMI	4-7
C-more LED Status Indicators.....	4-8
Reset Button	4-9
RUN/STOP switch	4-9
User Defined LED	4-9
CM5-RHMI Beep.....	4-9

Safety Guidelines



NOTE: *Products with CE marks perform their required functions safely and adhere to relevant standards as specified by CE directives provided they are used according to their intended purpose and that the instructions in this manual are adhered to. The protection provided by the equipment may be impaired if this equipment is used in a manner not specified in this manual. A listing of our international affiliates is available on our website: <http://www.automationdirect.com>*



WARNING: Providing a safe operating environment for personnel and equipment is your responsibility and should be your primary goal during system planning and installation. Automation systems can fail and may result in situations that can cause serious injury to personnel or damage to equipment. Do not rely on the automation system alone to provide a safe operating environment. You should use external electromechanical devices, such as relays or limit switches, that are independent of the PLC application to provide protection for any part of the system that may cause personal injury or damage. Every automation application is different, so there may be special requirements for your particular application. Make sure you follow all national, state, and local government requirements for the proper installation and use of your equipment.

Plan for Safety

The best way to provide a safe operating environment is to make personnel and equipment safety part of the planning process. You should examine every aspect of the system to determine which areas are critical to operator or machine safety. If you are not familiar with control system installation practices, or your company does not have established installation guidelines, you should obtain additional information from the following sources.

- NEMA — The National Electrical Manufacturers Association, located in Washington, D.C. publishes many different documents that discuss standards for industrial control systems. You can order these publications directly from NEMA. Some of these include:
 - ICS 1, General Standards for Industrial Control and Systems
 - ICS 3, Industrial Systems
 - ICS 6, Enclosures for Industrial Control Systems
- NEC — The National Electrical Code provides regulations concerning the installation and use of various types of electrical equipment. Copies of the NEC Handbook can often be obtained from your local electrical equipment distributor or your local library.
- Local and State Agencies — many local governments and state governments have additional requirements above and beyond those described in the NEC Handbook. Check with your local Electrical Inspector or Fire Marshall office for information.

Introduction

The installation and wiring of the **C-more**® CM5-RHMI requires selecting an appropriate location for the HMI in the control cabinet that it will be mounted in, securing the unit to the DIN Rail or mounting it to the back panel of the enclosure with screws, and connecting the appropriate power source to the HMI.

This chapter covers the proper mounting of the CM5-RHMI and connecting power. Once power is applied to the unit, the user will want to read Chapter 5, System Setup Screens, in order to set the internal time and date for the unit, become familiar with the HMI test features, and check memory options.

Mounting

DIN Rail Mounting

CM5-RHMI can be mounted vertically on a standard 35mm x 7.5mm height DIN rail (Standard: CENELEC EN50022).

1. Pull the bottom retaining tab of the CM5-RHMI down.
2. Position the CM5-RHMI on the DIN rail.
3. Push the retaining tab up until it clicks to secure the CM5-RHMI on the DIN rail.

Panel Mounting

CM5-RHMI can be mounted vertically on a panel using the tabs located on the back of the unit.

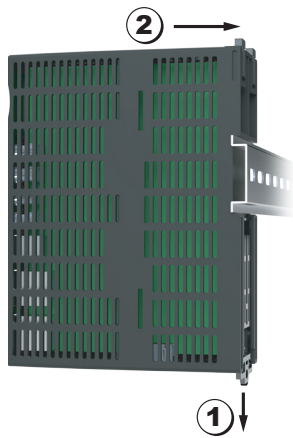

1. Fully extend the three mounting tabs located on the top and bottom of the unit.



2. Secure to a panel using three #8 standard or M4 metric screws and appropriate hardware.

Mounting Clearances

The following drawing shows the mounting clearances for the **C-more** RHMI. There should be a minimum of 2 inches of space on top and sides and 3 inches on the bottom from the nearest object or obstruction. There should also be a minimum of 1.75 inches of space in front of the unit to allow for the bend radius of any cables attached.

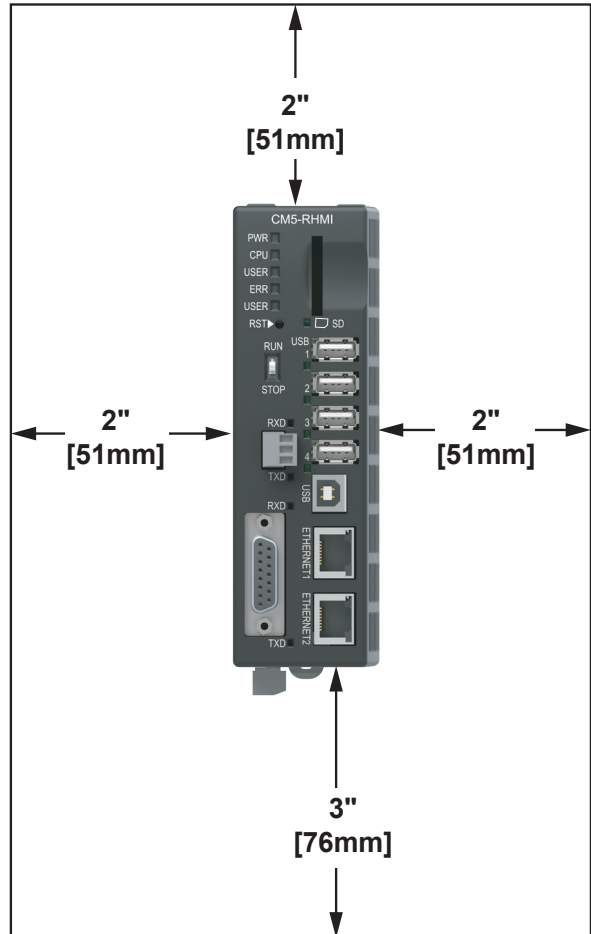
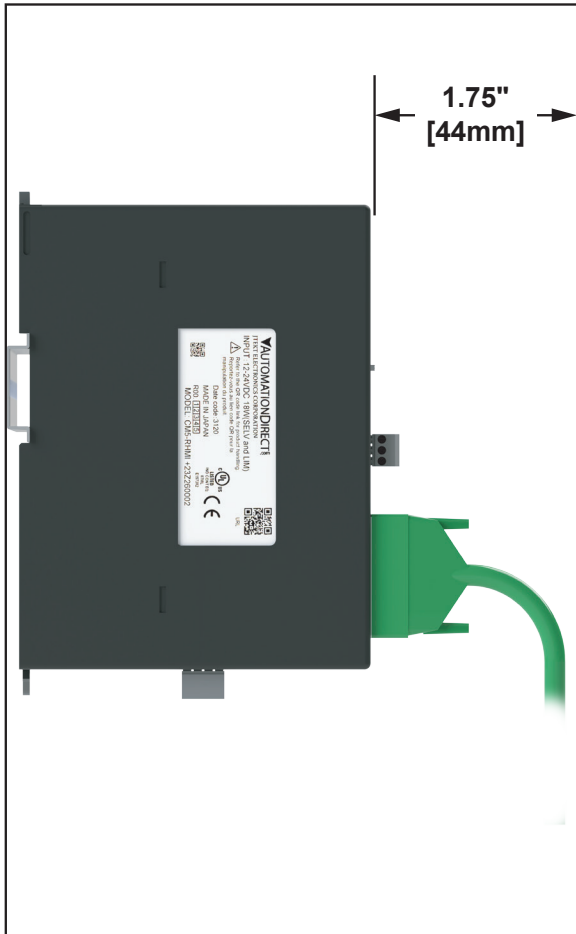

Wiring Guidelines



WARNING: To minimize the risk of potential safety problems, you should follow all applicable local and national codes that regulate the installation and operation of your equipment. These codes vary from area to area and it is your responsibility to determine which codes should be followed, and to verify that the equipment, installation, and operation are in compliance with the latest revision of these codes.

Equipment damage or serious injury to personnel can result from the failure to follow all applicable codes and standards. We do not guarantee the products described in this publication are suitable for your particular application, nor do we assume any responsibility for your product design, installation, or operation.

If you have any questions concerning the installation or operation of this equipment, or if you need additional information, please call technical support at 1-800-633-0405 or 770-844-4200.

This publication is based on information that was available at the time it was printed. At Automationdirect.com® we constantly strive to improve our products and services, so we reserve the right to make changes to the products and/or publications at any time without notice and without obligation. This publication may also discuss features that may not be available in certain revisions of the product.

Agency Approvals

Some applications require agency approvals for particular components. **C-more** agency approvals are listed below:

- UL (Underwriters' Laboratories, Inc.)
- cUL (Canadian Underwriters' Laboratories, Inc.)
- CE (European Economic Union)

Wiring Guidelines (cont'd)

Providing Power to the HMI

- **Connect a dedicated** 12-24 VDC Class 2 power supply to the DC connector on the front of the **C-more** CM5-RHMI, include wiring the ground terminal to a proper equipment ground
- **Then** turn on the power **source** and check the LED status indicators on the front of the **C-more** CM5-RHMI for proper indication (see next page)



NOTE: A dedicated power supply is recommended. If the power supply also feeds inductive loads such as solenoids or relays, the transients caused by these loads can affect the operation of the unit or damage HMI components.

DC Power Wiring

Recommended Fuse	
Rating	ADC part number
5 A	MDL-5

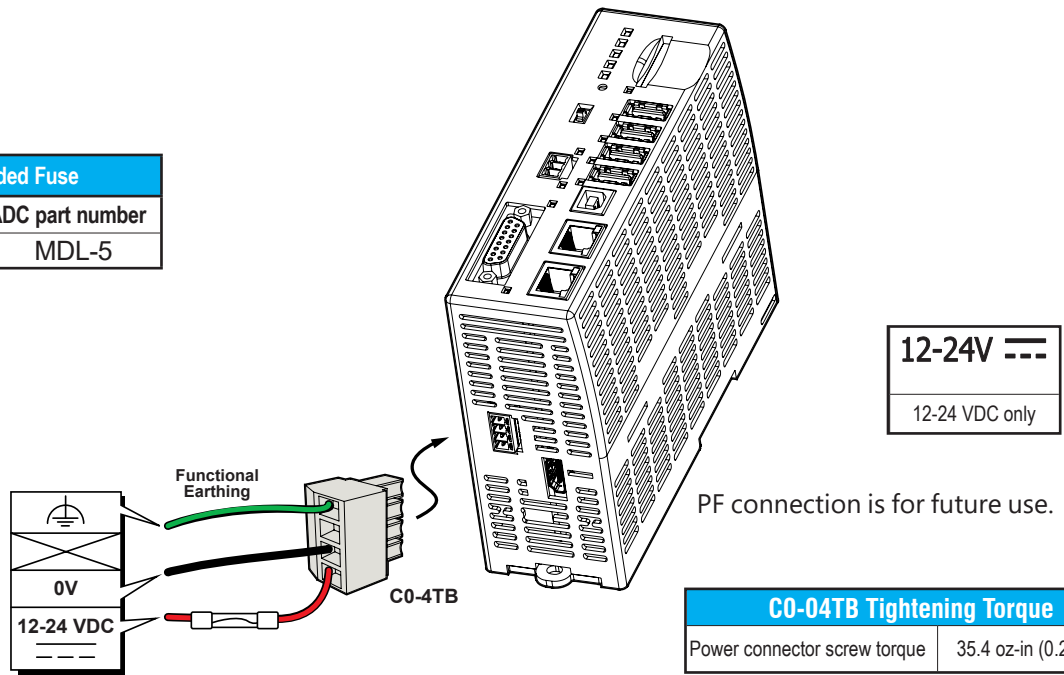

C0-04TB Tightening Torque	
Power connector screw torque	35.4 oz-in (0.25 Nm)



Warning: Use 60/75°C copper conductors only.

C-more LED Status Indicators

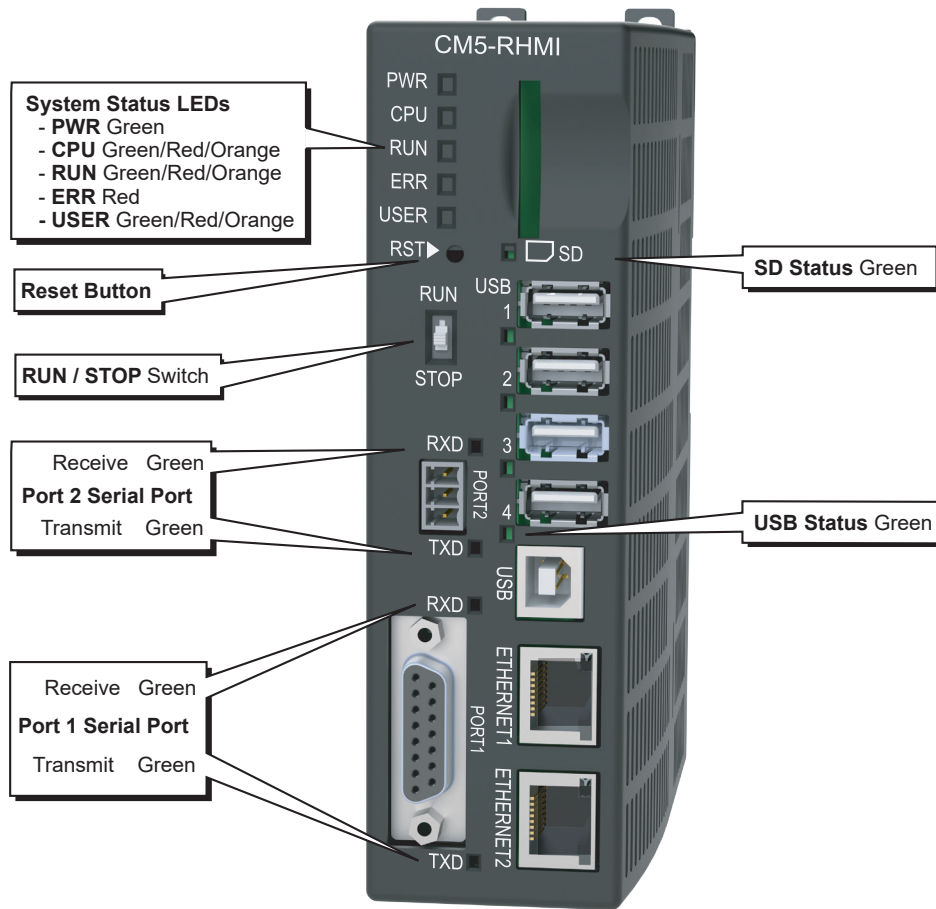

System Status LEDs				
State	LED	CPU	RUN	ERR
Loading Project		–	Blinking Green (0.2s)	–
Loading OS		Blinking Green (0.5s)	–	OFF
CPU Running Normally		Green	–	OFF
Project Loaded and Running		–	Green	–
No User Project		–	Orange	–
Reset to Factory Default		Blinking Green (0.5s)	Blinking Green (0.5s)	Blinking Red (0.5s)
System Screen		–	OFF	–
Password Required		–	Blinking Orange (0.5s)	Blinking Red (0.5s)
Errors	Power Loss Detection	Blinking Orange (0.2s)	–	–
	Memory Error	Red	OFF	Red
	OS Error	Blinking Orange (0.5s)	OFF	Red
	No Log Storage Found	–	Blinking Orange (0.5s)	Blinking Red (0.5s)
	General Error*	–	Red	Blinking Red (0.5s)
	Warning*	–	Blinking Orange (0.5s)	Blinking Red (0.5s)
	Safe Mode	Orange	OFF	Red

*Note - See Chapter 8 — Troubleshooting for General Error and Warning explanations.

Reset Button

Reset Button		
Push Action	Behavior	Note
Push for <15 seconds	Reboot the CM5-RHMI	—
Push for >15 seconds	Reset to factory default	The project is cleared and all settings are initialized.
Hold down the button and power on the CM5-RHMI	Safe Mode	The Error LED will be RED and the CPU LED will blink ORANGE. See “No System Found” in Chapter 8 - Troubleshooting

RUN/STOP switch

RUN / STOP Switch		
Position	Behavior	Note
RUN	Project will run if present and the RUN LED will be green	If no project is loaded in the HMI, the message “No Program Found” will be displayed. The RUN LED will blink orange.
STOP	The project and any logging stops and the System Screen is displayed.	If a password has been set up for the System Screen, the RUN LED will blink orange.
Power on the CM5-RHMI while in the STOP position	After the project is loaded into memory the System Screen is displayed	A System Screen password is ignored.

User Defined LED

The user defined LED on the CM5-RHMI can be controlled from the project to illuminate red, green or orange. It can also be configured to blink these colors. Refer to the online help file provided with the programming software for details.

CM5-RHMI Beep

Beep Functions	
Function	Beep Pattern
Boot	1-long, 2-short
Boot Error*	3-long
HDMI Connected	3-short
Reset to Factory Defaults	14 short beeps progressively closer together followed by 1-long beep.
Blink Screen	5-long
<p>*Boot Errors</p> <ul style="list-style-type: none"> Multiple Projects Write Protected SD Card No Log Storage Found Password Protected 	

BLANK
PAGE

SYSTEM SETUP SCREEN



CHAPTER

5

In this Chapter...

Introduction	5-4
Information	5-4
Settings.....	5-4
Test Menu	5-4
Memory.....	5-4
Accessing the System Setup Screens (no project loaded)	5-5
Accessing the System Setup Screens (with project loaded)	5-6
Using RHMI USB Remote	5-7
System Setup Screens	5-9
Password Protecting System Screen Access.....	5-9
System Setup Screens - Enable Password in Software	5-10
System Setup Screens Flowchart	5-16
Main Menu	5-17
Information Screen	5-18
Information - General Tab.....	5-18
Information - Memory Tab	5-19
Information - Ethernet Tab	5-20
Information - Error Tab	5-21
Error Message Format	5-21
Error Message Navigation Buttons	5-21
Information - License Tab	5-22
Settings Screen	5-23
Settings - Adjust Clock.....	5-24
Settings - Touch Panel.....	5-25
Settings - Network Settings.....	5-28
Settings - Adjust Display.....	5-29
Settings - Options	5-30
System Screen Theme	5-30
Enable Beep	5-30
Show Mouse Cursor	5-30

Test Menu	5-31
Test Menu - Test Touch Panel.....	5-32
Testing.....	5-32
Test Menu - Test Beep/Audio	5-33
Test Menu - Test Serial Port	5-34
Test Menu - PLC Serial Comm Port - Loop back test	5-35
Test Results	5-35
Test Menu - PLC Enquiry Test: Serial Connection.....	5-36
PLC Enquiry Test.....	5-36
Test Menu - Test Ethernet Port	5-37
Test Menu - PLC Enquiry Test: Ethernet Connection.....	5-38
PLC Enquiry Test.....	5-38
Test Menu - Test Display.....	5-39
Check Available Resolutions on External HDMI Display	5-40
Test Menu - Test User LED.....	5-41
Memory Screen	5-42
Saving to an External Memory Device	5-43
Increasing Project Memory Size using an SD memory card.....	5-43
Memory - Backup	5-44
SD1 Availability	5-45
Backup Data Files Naming and Organization	5-46
Backup Warning Messages.....	5-48
Memory - Restore.....	5-49
Memory - Clear Memory	5-53
Memory Clear Warning Message.....	5-56
Memory - Reset to Factory Default	5-57

BLANK
PAGE

Introduction

The **C-more** touch panels include a series of built-in System Setup Screens that allow the user to view detailed information about the panel; adjust certain features; configure communications; test various functions of the touch panel; backup & restore firmware, recipe, log and project memory; clear memory and reset all values and conditions back to the original factory defaults.

The four Main Menu selections are:

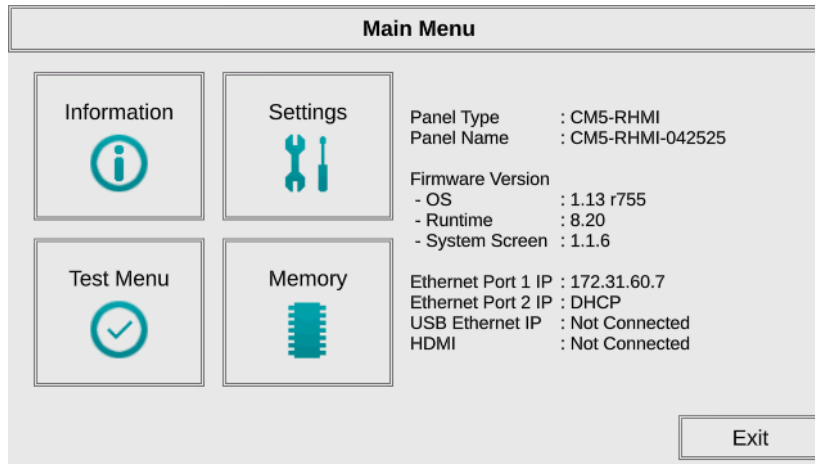

Information

The information tabs display details about the HMI hardware, firmware, features enabled, memory status, Ethernet port settings, panel errors and license information.

Settings

The Settings menu allow adjustments to be made to the internal clock, touch screen calibration, Ethernet port settings, display brightness and enabling or disabling other options.

Test Menu

The Test menu is used to test the touch screen, audio outputs, serial and Ethernet PLC connections, display colors and pixels and User LEDs.

Memory

The Memory menu is used to Backup and Restore the panel firmware and project, clear the panel memory or reset the HMI to a factory default state.

Accessing the System Setup Screens (no project loaded)

To access the Main Menu of the CM5-RHMI System Setup Screens with a project loaded into memory, move the RUN/STOP switch to the STOP position.

If the RUN/STOP Switch is not accessible, a Key Button Object can be added to a screen in the **C-more** HMI project to access the System Screens. See the **C-more** Programming Software Help File Topic, “Key Button Object” for more information.

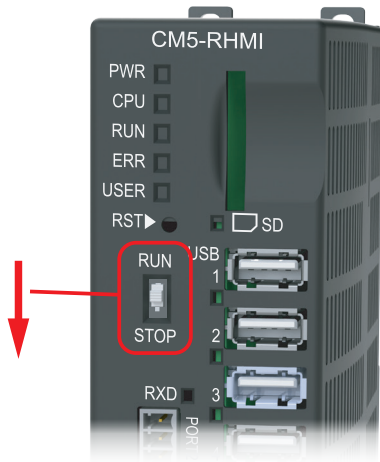

If the Key Button is used and no system screen password is enabled, the following WARNING dialog box will appear on the connected screen:

- Pressing OK will display the system setup screen. See the WARNING below!
- Pressing Cancel will take you back to the project screen.
- Communication with the PLC is active while the Warning is displayed.
- The dialog box will close if no action is taken for 60 seconds.
- The dialog box will not display if the HMI does not have a project loaded.
- The dialog box will display after a valid password is entered if the System Screen password is enabled.

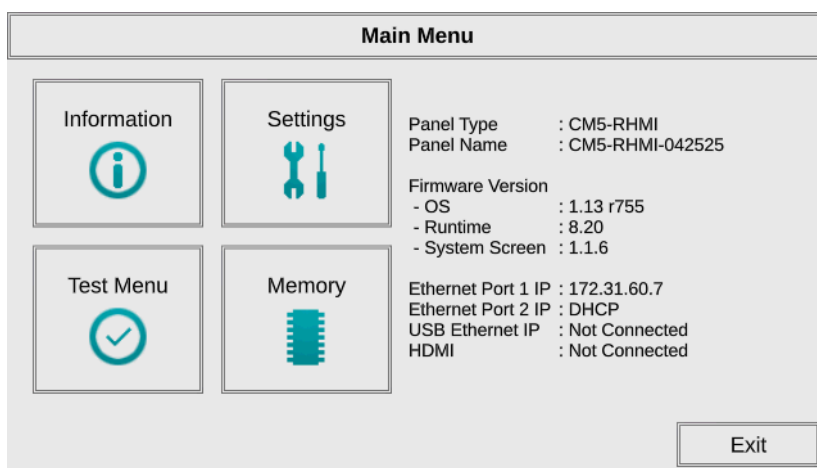

WARNING: This will STOP the PLC driver and therefore all communications between the CM5-RHMI and PLC will cease. In addition, moving the RUN / STOP switch to the STOP position does not display this warning. This is why it is strongly recommended that the password system tag “SYS SYSTEMSCREENPW” be enabled to add a safeguard step in accessing the system setup screens. See the next section for an overview of how to set the System Tags in the Event Manager Database.

Accessing the System Setup Screens (with project loaded)

There are three ways to access the System Setup Screens in the CM5-RHMI.

- 1) On the HMI by moving the RUN/STOP switch to the STOP position.
- 2) From a connected compatible touch screen using the Key Button Object.
- 3) From the C-more Software and using the RHMI USB Remote utility.

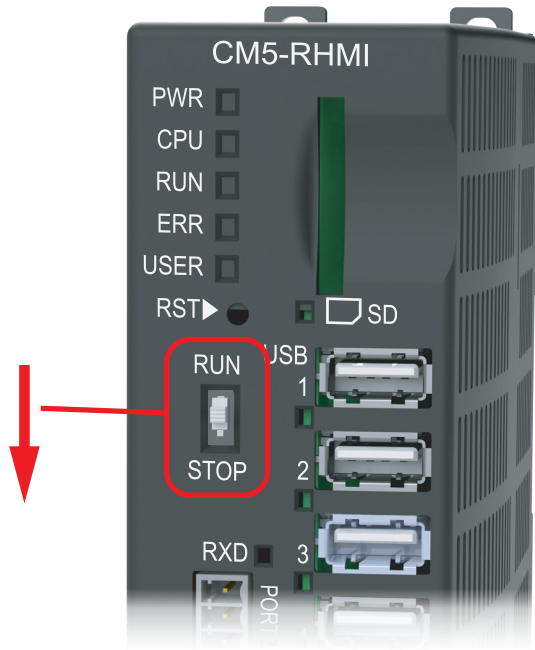

If the RUN/STOP Switch is not accessible, a Key Button Object can be added to a screen in the **C-more** HMI project to access the System Screens. See the **C-more** Programming Software Help File Topic, “Key Button Object” for more information.

If the Key Button is used and no system screen password is enabled, the following WARNING dialog box will appear on the connected screen:

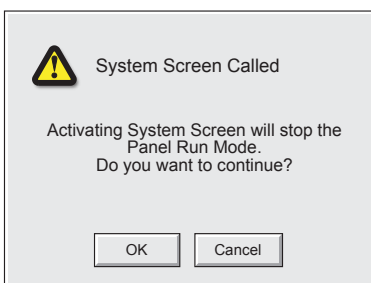

- Pressing OK will display the system setup screen. See the WARNING below!
- Pressing Cancel will take you back to the project screen.
- Communication with the PLC is active while the Warning is displayed.
- The dialog box will close if no action is taken for 60 seconds.
- The dialog box will not display if the HMI does not have a project loaded.
- The dialog box will display after a valid password is entered if the System Screen password is enabled.



WARNING: This will STOP the PLC driver and therefore all communications between the CM5-RHMI and PLC will cease. In addition, moving the RUN / STOP switch to the STOP position does not display this warning. This is why it is strongly recommended that the password system tag “SYS SYSTEMSCREENPW” be enabled to add a safeguard step in accessing the system setup screens. See the next section for an overview of how to set the System Tags in the Event Manager Database.

Using RHMI USB Remote

Another option for seeing the System Screens is through a PC connected by USB to the CM5-RHMI.

When a monitor is not attached to the RHMI, the RHMI USB Remote feature can be used to view and operate the RHMI screens and System Screens.

Connect the PC to the RHMI with a USB cable from the USB type B port on the RHMI to a USB Type A port on the PC running the software. See the CM5-RHMI User Manual Chapter 1 for more details on connecting the CM5-RHMI to a computer.

In the **C-more** programming software go to the Panel tab and select RHMI USB Remote.

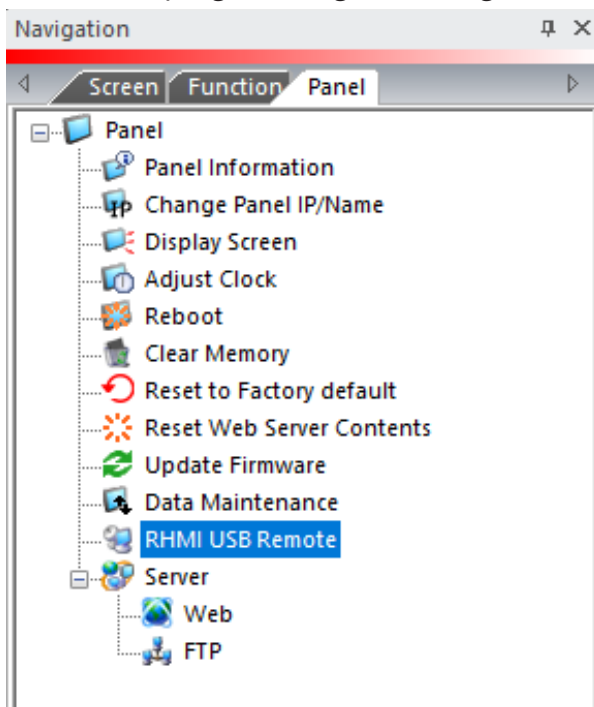

The RHMI USB Remote displays the same screen that is shown on a connected HMI monitor.

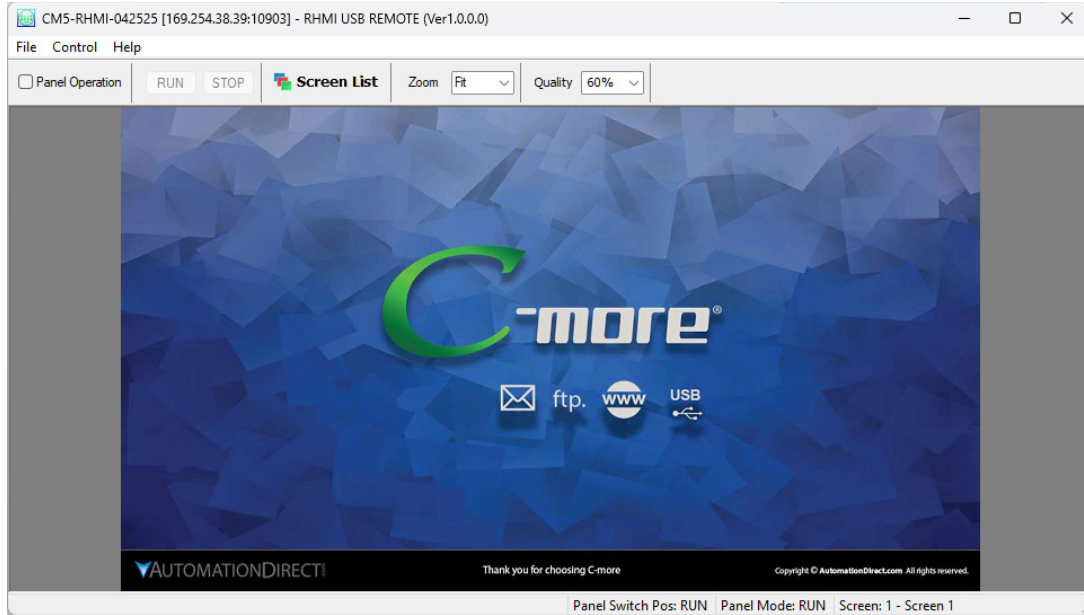

NOTE: The RHMI USB Remote selection is only available if the panel is connected to the PC by a USB cable.

Panel Operation: This allows the screens to be clicked with a mouse and operated as if you were touching a touch screen connected to the HMI.

RUN STOP: If the RHMI's RUN/STOP Switch is in the RUN position, you can select STOP to see the System Screen. If the Switch is in the STOP position already, the System Screen will already be displayed.

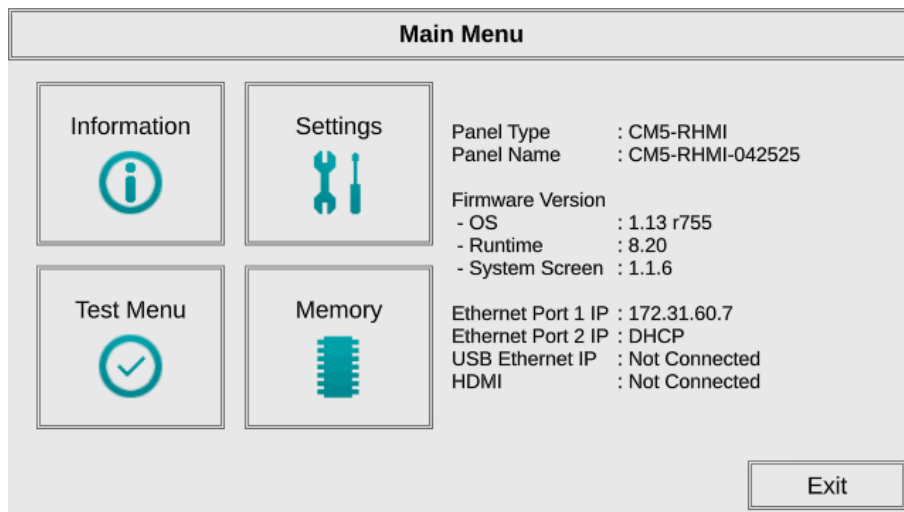

System Setup Screens

Pressing the OK button in the Warning dialog box will bring up the Main Menu as shown below. You can then proceed to the other system setup screens.

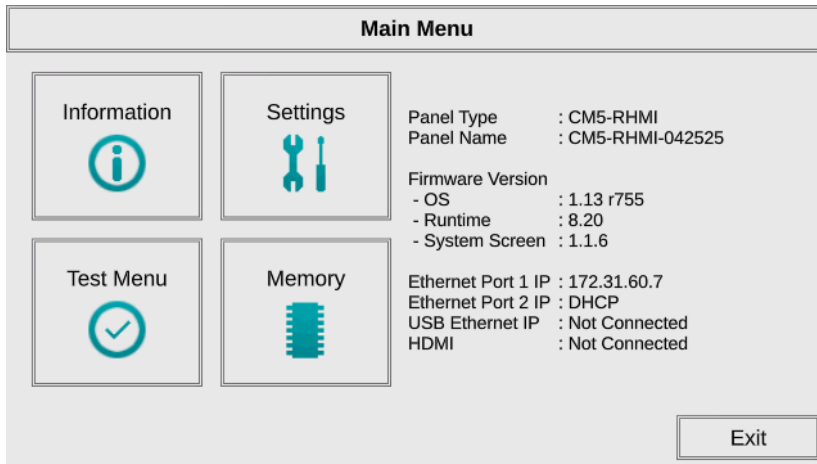

Password Protecting System Screen Access



*NOTE: If the password system tag **SYS SYSTEMSCREENPW** is enabled, the Enter Security Code keypad shown below will open. The following procedure details enabling the **SYS SYSTEMSCREENPW**. Entering the correct password will display the Panel Run Mode warning dialog described previously. PLC communications continue while the keypad is displayed. The keypad will timeout after 60 seconds.*



System Setup Screens — Enable Password in Software

Under the **C-more** Programming Software’s Navigation window, select the Function tab, then double click on “Alarm Action” to display the Event Manager Database shown below:

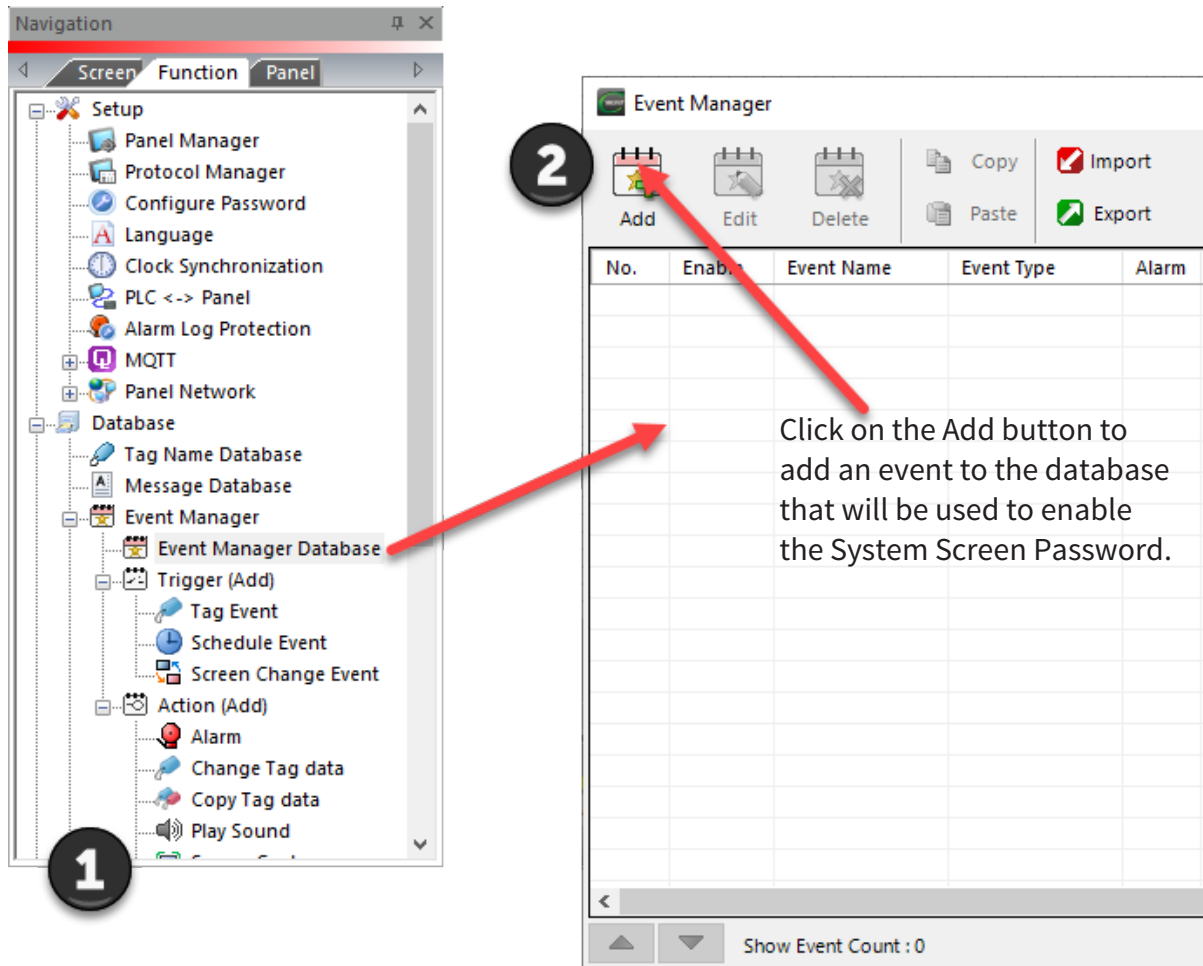

System Setup Screens – Enable Password (cont'd)

The **Event Add** dialog box will be displayed as shown.

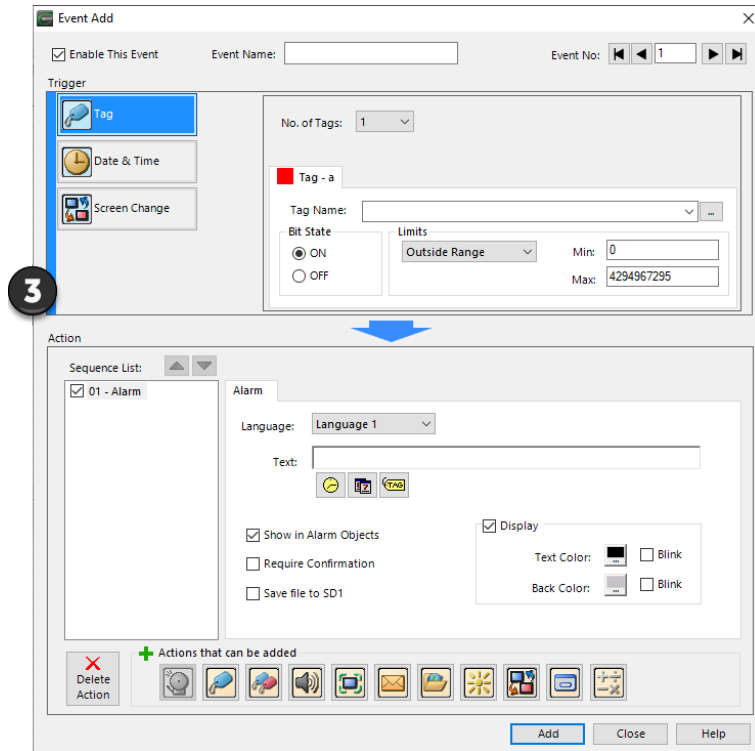

Click on the **Tag Name:** pull down menu and select the internal **System Bit On (SYS BIT ON)** tag as shown. This will force the tag event type to be continuously active.

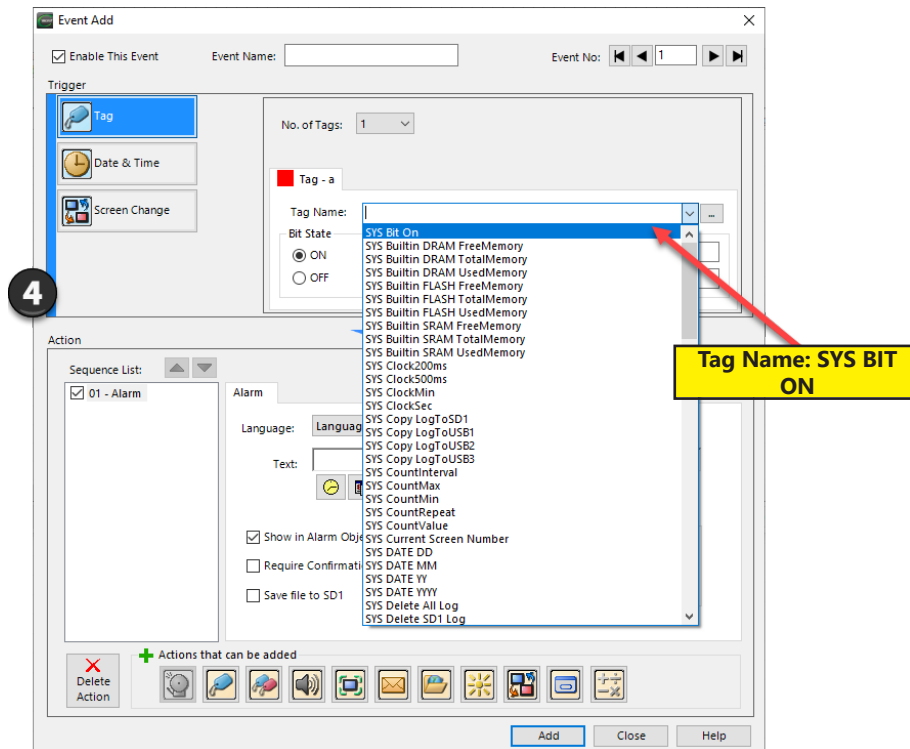

System Setup Screens – Enable Password (cont'd)

Use the **Event Name:** text box to document the event as “System Screen PW” for record keeping. This is optional.

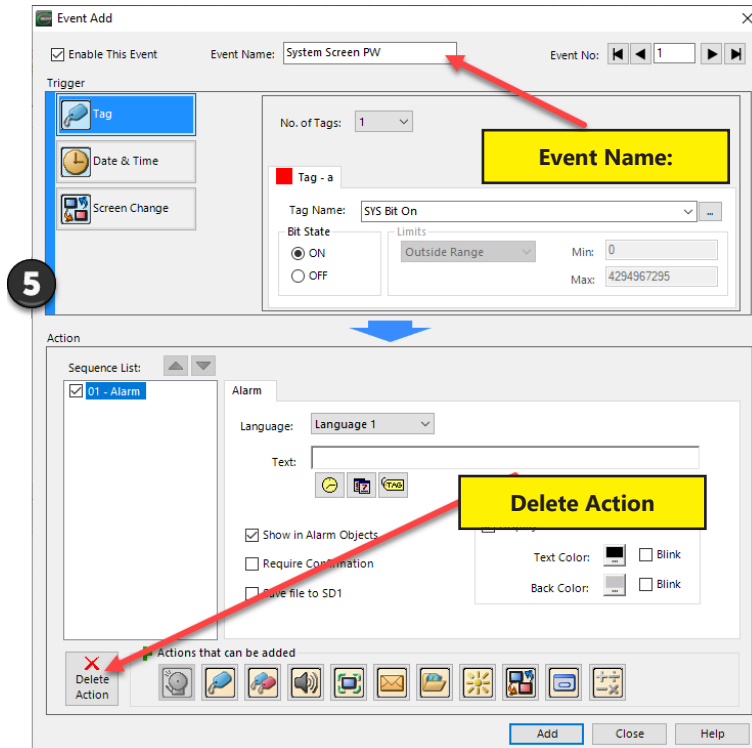

In the Action box, click once on the displayed 01-Alarm under the Sequence List: so that 01-Alarm is highlighted. Then click the **Delete Action** button to remove the **01-Alarm**.

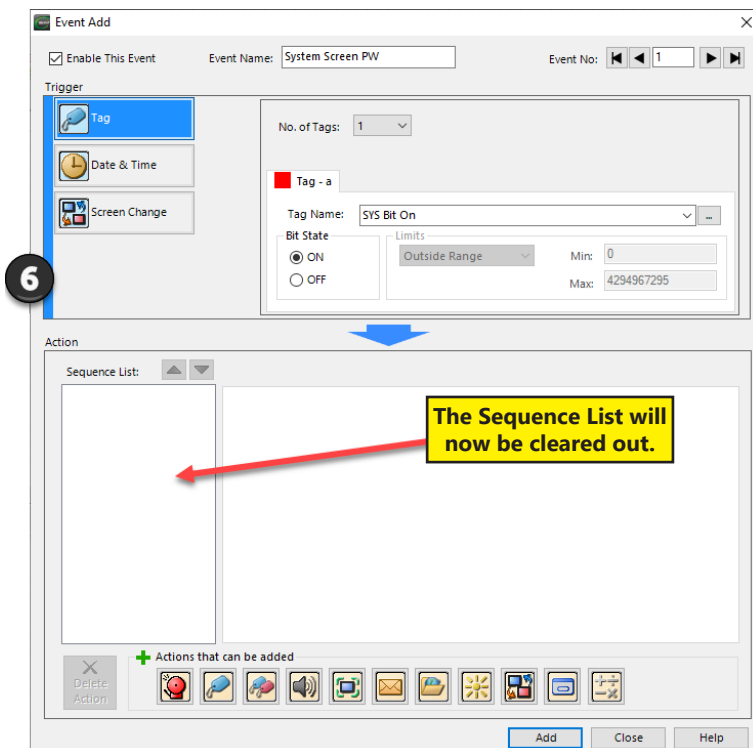

System Setup Screens – Enable Password (cont'd)

From the **Add Action** icons, click on the **Tag Action** button.

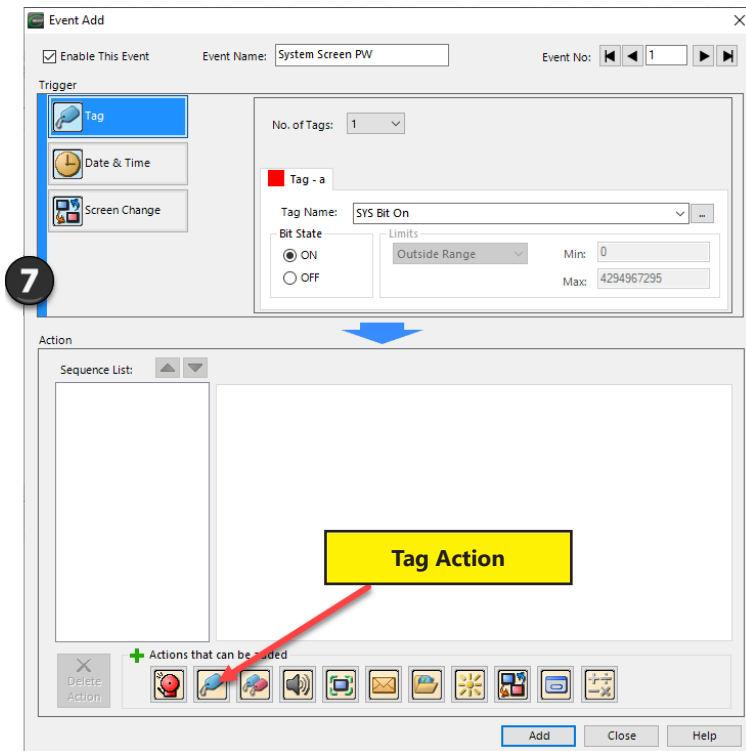

A **01-Tag** action item will then be added to the Sequence List.

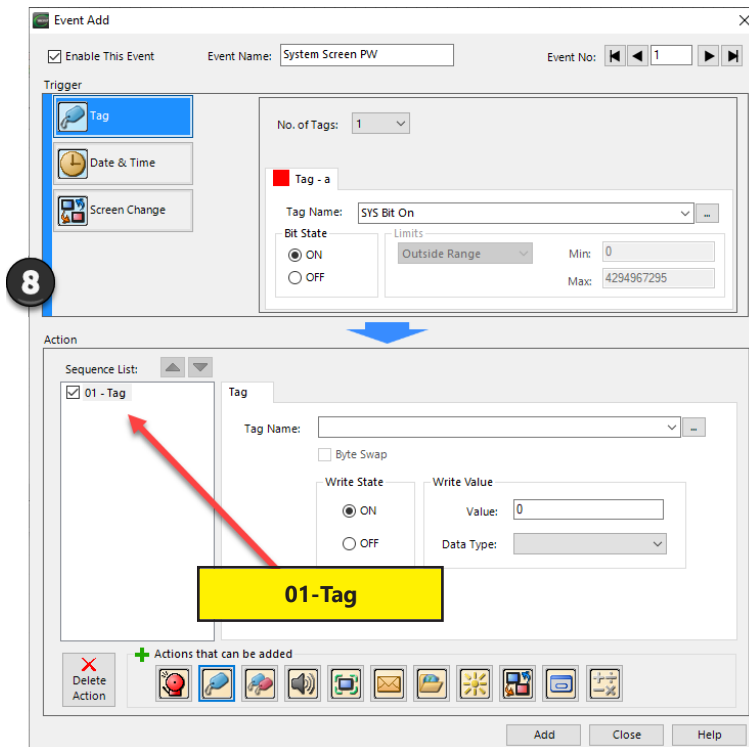

System Setup Screens – Enable Password (cont'd)

Click on the **Tag Name:** drop down list down arrow and select **SYS SYSTEMSCREENPW** from the list.

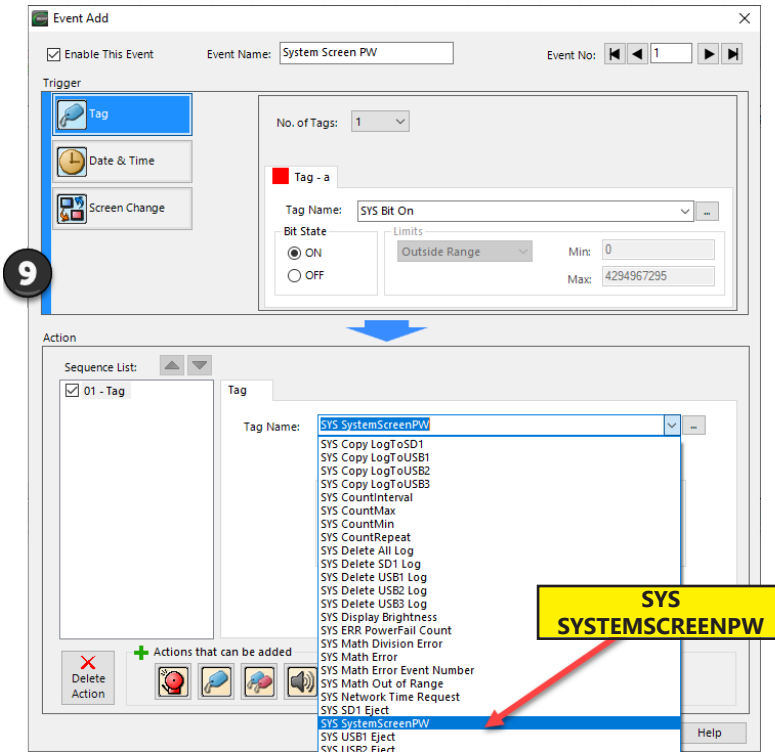

Enter a numeric value into the **Value:** box, such as “777”. This value becomes the Password code to access the System Setup Screen’s **Main Menu**.

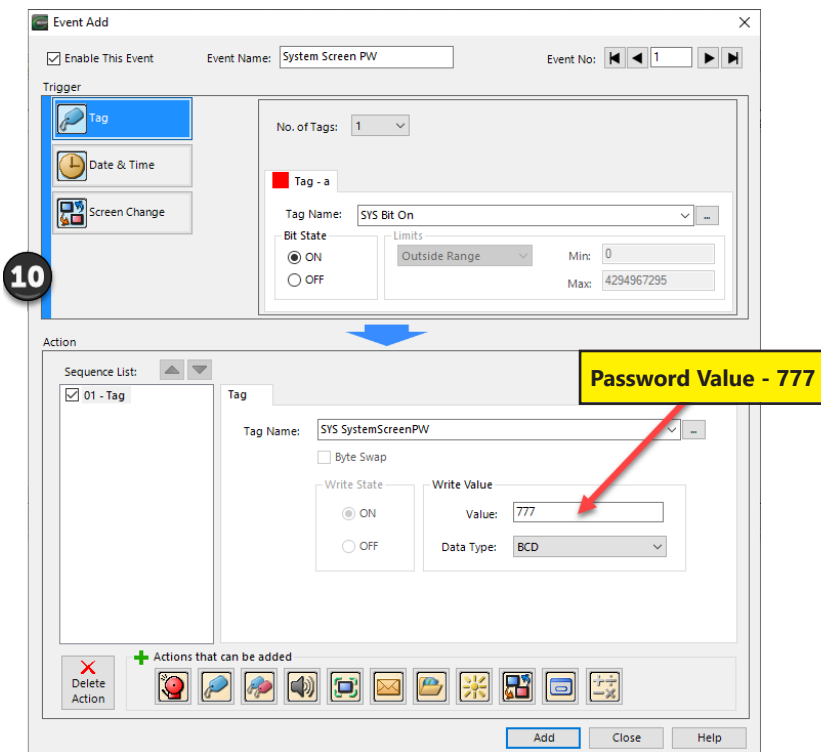

System Setup Screens – Enable Password (cont'd)

Click the **Add button** to return to the Event Manager Database. You now will see that the first event in the database is for the System Screen Password and it is enabled.

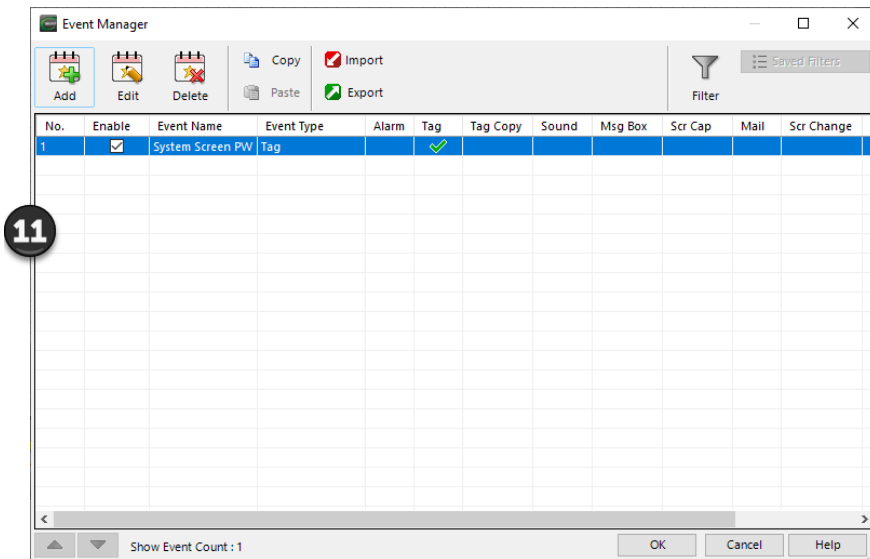

System Setup Screens Flowchart

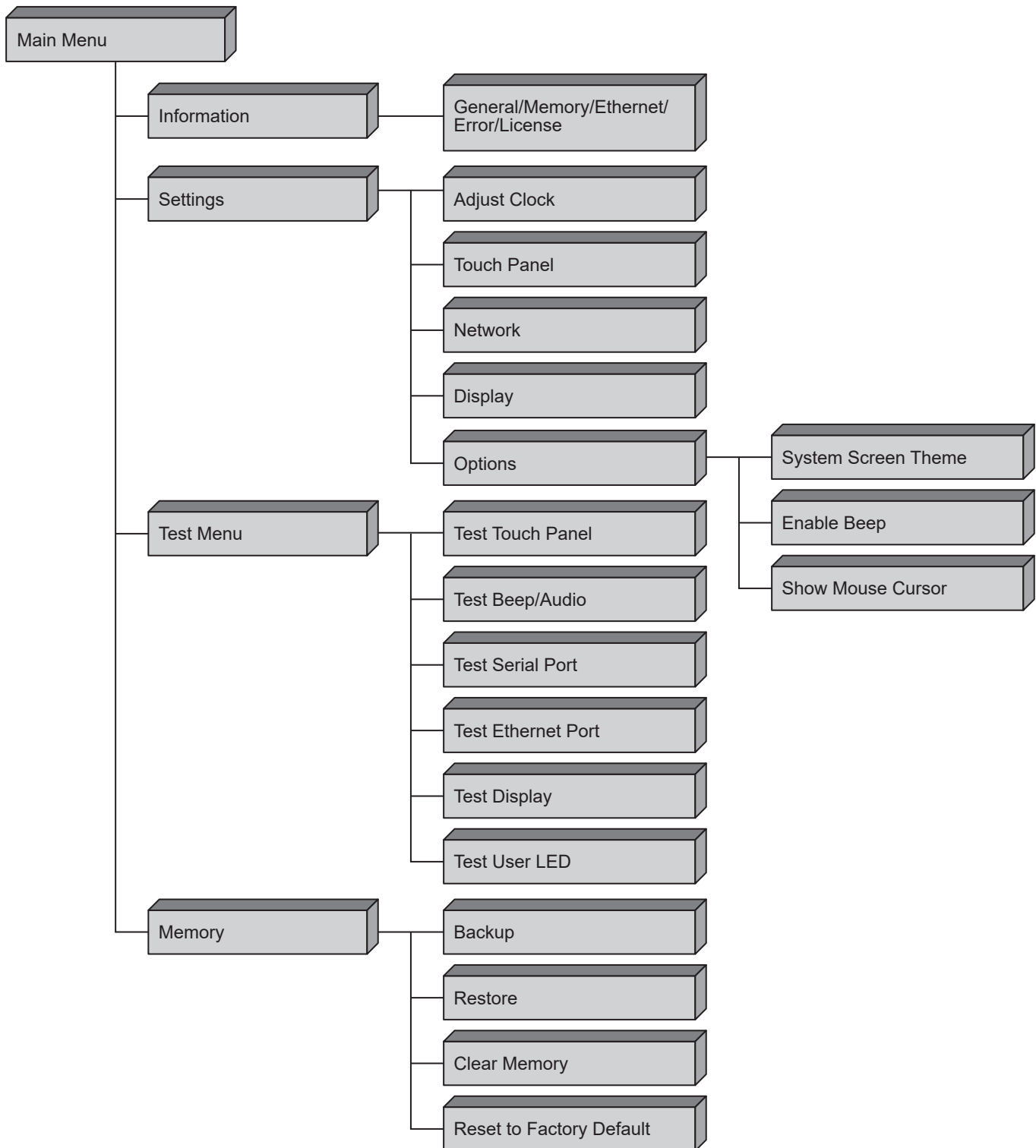

Main Menu

The Main Menu system setup screen is the top layer in the menu structure.

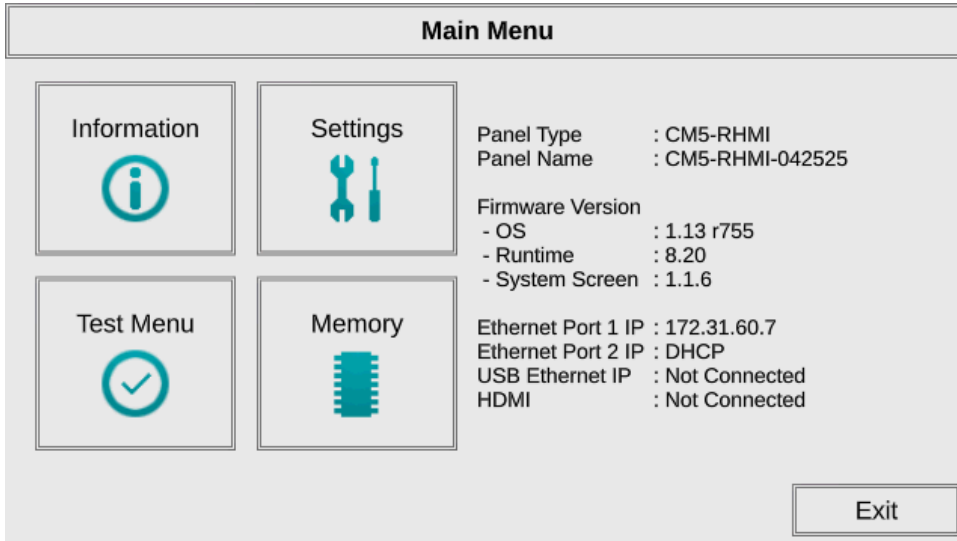

Information Screen

Information — General Tab

The General tab under the Information Screen provides detailed information of the **C-more** touch panel.

Information				
General	Memory	Ethernet	Error	License
Panel Type	: CM5-RHMI			
Panel Name	: CM5-RHMI-042525			
Version				
Hardware	: 00-00-00-00			
Boot Loader	: 01			
Firmware				
- OS	: 1.15 r743			
- Runtime	: 8.20			
- System Screen	: 1.1.6			
Clock	: Internal			
Beep	: Enabled			
Project Boot Storage	: Built-in FLASH			
HDMI	: Connected (Resolution: 1920x1080)			

Close

Item No.	Function	Description	Comments
1	Panel Type	CM5-RHMI	Model Number
2	Panel Name	The panel name is configured in the programming software and saved with a project.	The default panel name is the model number plus the lower three bytes of the panel MAC address, ie CM5-RHMI-0022C4.
3	Version	The version identifications provide information on the components and firmware in the panel	Files reside in the C-more touch panel's memory
4	Clock	Internal/External - Network Time Service (UTC Time)	Configured in the C-more Programming Software. This can be HMI's internal clock, a PLC or a time server such as time.windows.com.
5	Beep	Status of the internal beeper	Enabled or Disabled. This setting is over written by the project Protocol Manager settings.
6	Project Boot Storage	SD Built-in FLASH	SD: SD Card in SD1 slot Built-in FLASH: Panel internal FLASH memory
7	HDMI	HDMI connection to an external screen	Connected, Not Connected

Information – Memory Tab

Information				
General	Memory	Ethernet	Error	License
	Total	Used	Free	
SDRAM:	428.7 MB	319.2 MB	109.5 MB	
SRAM:	512.0 KB	124.0 KB	388.0 KB	
Built-in Flash:	43.0 MB	145 B	43.0 MB	
SD1:	1.8 GB	1.2 MB	1.8 GB	
USB1:	58.7 GB	32.0 KB	58.7 GB	

Resource Monitor Close

- 1) **Memory components** - Status of each memory component - SDRAM, SRAM and Built-in Flash are internal memory components. When external memory devices are installed in the panel they will be included in this list : SD and USB. These can also be monitored using the System Tags. See Chapter 2, Handling External Memory Devices.
- 2) **Resource Monitor** - This troubleshooting tool displays CPU usage and panel internal memory usage. When enabled, the Resource Monitor will display on the panel screen even after the System Screen is closed, while the project is running.

Information – Ethernet Tab

Information

General	Memory	Ethernet	Error	License
	Ethernet Port 1	Ethernet Port 2		USB Ethernet Port
Link Status	: Online	: Offline		: Not Connected
MAC Address	: 00:06:48:02:66:FD	: 00:06:48:02:66:FC		
Address Type	: DHCP	: DHCP		
IP Address	: 172.31.60.36			
Subnet Mask	: 255.255.254.0			
Default Gateway : 172.31.60.1				
DNS Server : DHCP				
Preferred DNS : 8.8.8.8				
Alternate DNS : 8.8.4.4				

Item No.	Function	Description	Comments
1	<i>Ethernet Status</i>	Ethernet Port Settings: Link Status: Online/Offline MAC Address: 00 06 48 XX XX XX Address Type: Static/DHCP IP Address: Subnet Mask: Default Gateway: DNS Server: Static/DHCP	Configurable in the Setting Screen – IP Address Setting shown in this section or in the C-more Programming Software. Not Connected - There is no USB to Ethernet Adapter in a USB port.

Information — Error Tab

Information				
General	Memory	Ethernet	Error	License
No	Time	Code	Error Message	
1	02/21/23 05:04:29	PLC-001	PLC Communication Timeout (ETHERNET,DEV001,RC	
2	02/21/23 05:04:19	PLC-001	PLC Communication Timeout (ETHERNET,DEV001,RC	
3	02/21/23 05:04:09	PLC-001	PLC Communication Timeout (ETHERNET,DEV001,RC	
4	02/21/23 05:03:59	PLC-001	PLC Communication Timeout (ETHERNET,DEV001,RC	
5	02/21/23 04:51:20	PLC-001	PORT2 - PLC Communication Timeout (COM2,PORT2.	
6	02/21/23 04:51:19	PLC-001	PORT2 - PLC Communication Timeout (COM2,PORT2.	
7	02/21/23 04:51:19	PLC-001	PORT1 - PLC Communication Timeout (COM1,PORT1.	
8	02/21/23 04:51:18	PLC-001	PORT2 - PLC Communication Timeout (COM2,PORT2.	
9	02/21/23 04:51:17	PLC-001	PORT2 - PLC Communication Timeout (COM2,PORT2.	
10	02/21/23 04:51:16	PLC-001	PORT2 - PLC Communication Timeout (COM2,PORT2.	
11	02/21/23 04:51:16	PLC-001	PORT1 - PLC Communication Timeout (COM1,PORT1.	

Error Message Format

Item No.	Function	Description	Comments
1	Date	Format: MM/DD/YY	Date error occurred.
2	Time	Format: HH/MM/SS	Time error occurred.
3	Error Code	The error code is the same as the code displayed in the upper left of the C-more touch panel's display.	A list of error codes are shown in Appendix A
4	Error Message	The Meaning of the error code	
5	Error Port	PLC Serial Communications Port: Ethernet:	
6	Device Name	The name of the device reporting the error.	Device names are configured in the Protocol Manager in the programming software.
7	Error Type	RD: Read WT: Write	
8	PLC Address	The assigned address of the PLC that caused the error.	
9	Access Bytes	The number of access bytes.	

Error Message Navigation Buttons

Item No.	Function	Description	Comments
1	Clear	Press to clear all error messages. This button is grayed out when there are no error messages to display.	
2	Scroll Down/Up	To scroll down and see more messages tap the bottom of scroll bar to the right. Or while touching in the Error list, drag your finger to move the list up and down.	
3	Page Right/Left	To scroll right to see the entire message tap the right side of the scroll bar on the bottom. Or while touching in the Error list, drag your finger to move the list left and right.	

Information – License Tab

The Operating System License information can be accessed from the Software by selecting the Help Tab>License Information Icon>Open the folder with the License file.

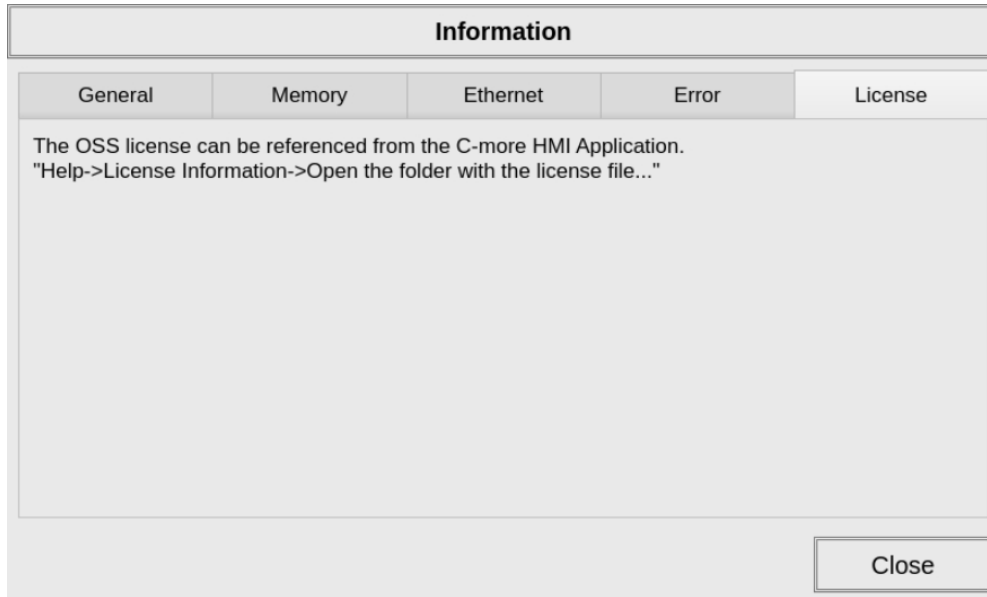

It can also be found in the “C:\Users\[user]\Documents\AutomationDirect\C-moreCM5\License” folder.

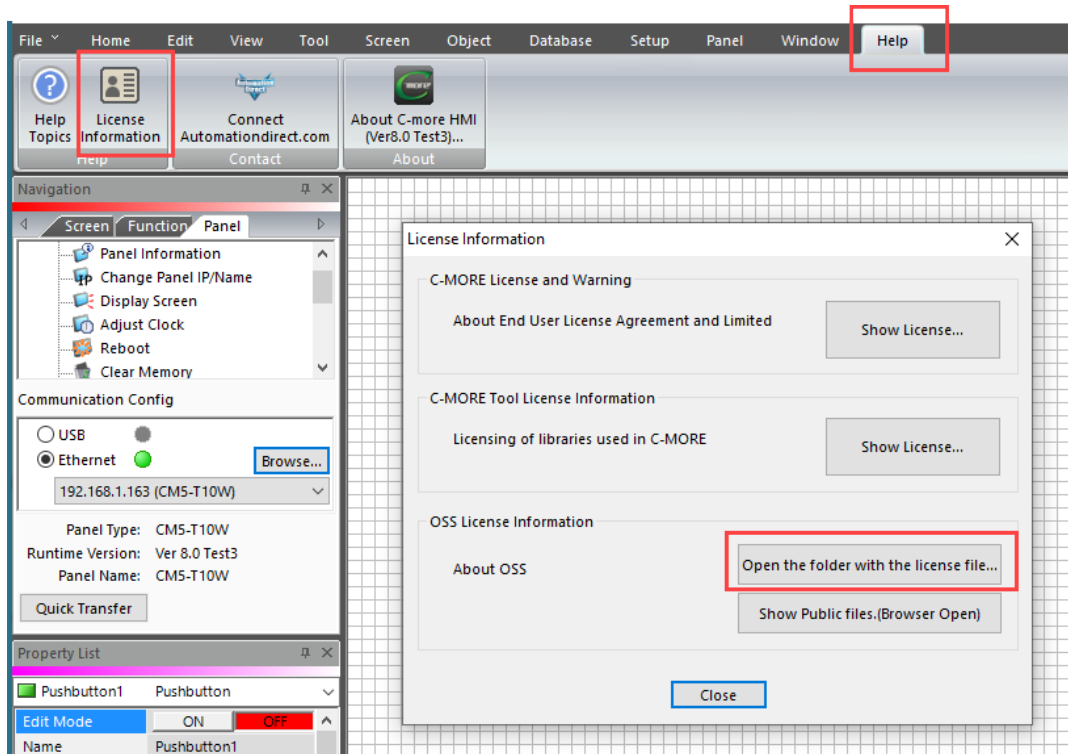

Settings Screen

The **Settings Screen** is used to adjust the internal clock, calibrate the touch screen, enter Ethernet port settings, adjust the display brightness, change the **System Screen** theme, along with enabling or disabling the mouse cursor and panel beep.

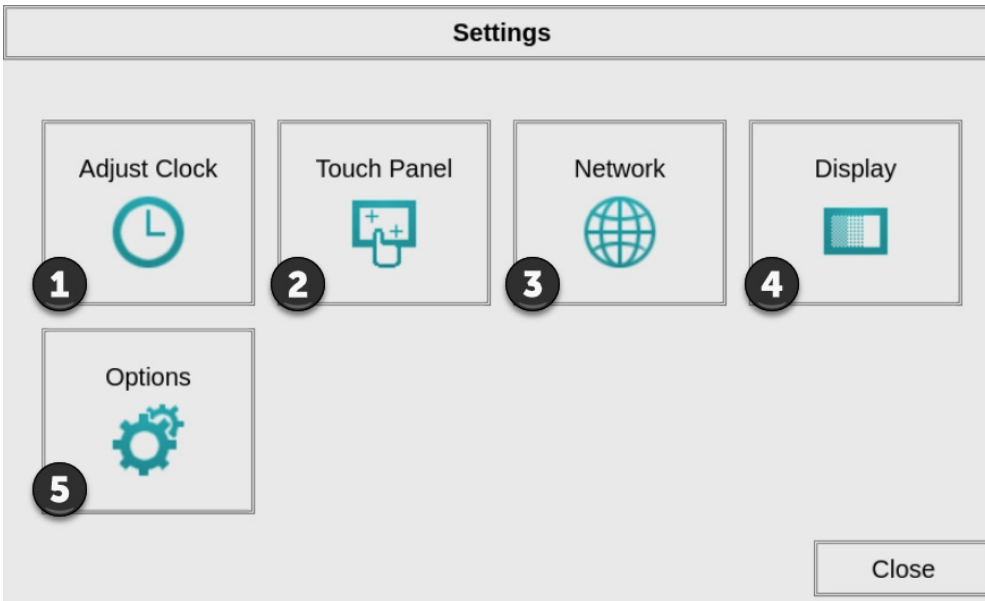

Item No.	Function	Description	Comments
1	Adjust Clock	Select to adjust the Time, Date and Time Zone on the HMI.	Time cannot be adjusted if an external time server is configured.*
2	Touch Panel	Select to calibrate the touch screen.	
3	Network	Select to configure the Ethernet Ports.	The IP Address can also be set from the programming software or by the project.*
4	Display	Select to adjust the brightness of the LED display	The Adjust Display object can also be used in the project.
5	Options	Select to enable or disable the panel beep and mouse cursor.	These are also project settings.*

*Project settings will override any changes on project transfer or a power cycle.

Settings — Adjust Clock

Adjust Clock

Time

Hour	Minute	Second
11	52	12

Date

Month	Day	Year
04	22	2024

Time Zone

(UTC-05:00) Indiana (East)

Clock Synchronization

Read from External Clock : Disable

Write to PLC Clock : Disable

OK

Cancel

Select Hour, Minute, Second, Month, Day or Year and use the keypad to enter a new value.

Adjust Clock

Time

Hour	Minute	Second
01	29	32

Hour

01

7	8	9	<div style="border: 1px solid gray; background-color: red; color: white; text-align: center; padding: 5px; margin-bottom: 5px;">ESC</div> <div style="border: 1px solid gray; background-color: yellow; text-align: center; padding: 5px; margin-bottom: 5px;">BS</div> <div style="border: 1px solid gray; background-color: yellow; text-align: center; padding: 5px; margin-bottom: 5px;">CLR</div> <div style="border: 1px solid gray; background-color: green; text-align: center; padding: 5px;">ENT</div>
4	5	6	
1	2	3	
0			

Clock Synchronization

Read from External Clock : Disable

Write to PLC Clock : Disable

OK

Cancel



NOTE: The clock settings on the panel's setup screen are disabled if an External clock source is selected in the C-more programming software. The choice of an internal or external clock source is available by selecting Clock Synchronization in the C-more programming software under the Main Menu Setup tab.



NOTE: The panel's clock can also be adjusted from the C-more programming software. The Adjust Clock function can be accessed in the software by selecting Adjust Clock under the Main Menu Panel tab or selecting Adjust Clock under the Panel tab in the software's Navigation window.

Settings – Touch Panel

Use this procedure to calibrate the touch screen for accuracy of touch areas. Calibration is based on five areas of the touch screen.

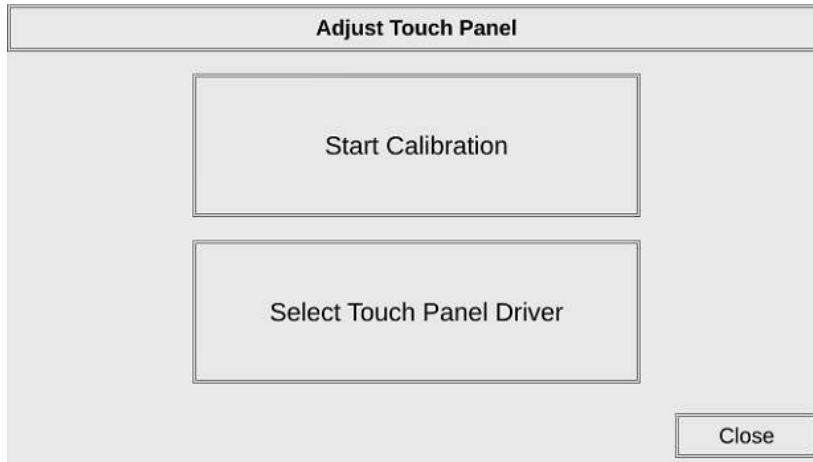

Item No.	Function	Description	Comments
1	Start Calibration	Press to begin the touch screen calibration.	—
2	Select Touch Panel Driver	Press to return to the Settings Screen.	If the touch calibration does not work correctly, a different touch panel driver may be required. Go to this screen to make a choice of selected drivers.
3	Close	Press to return to the Settings Screen.	—
4-8	Touch Points 3-7	The touch screen calibration crosshairs will appear individually in the order of point 3 thru 7 respectively as each proceeding crosshair is pressed.	If the touched co-ordinate point is too far off from normal, then it will not advance to the next point.

Start Calibration

- 1) Select Start Calibration.
 - The Touch Panel Calibration Screen opens.
- 2) Select all five calibration points (crosshairs) as they appear.
 - Select them carefully and use a stylus if necessary for accuracy.
 - If the touchscreen does not respond to touch, proceed to “Select Touch Panel Driver” below.

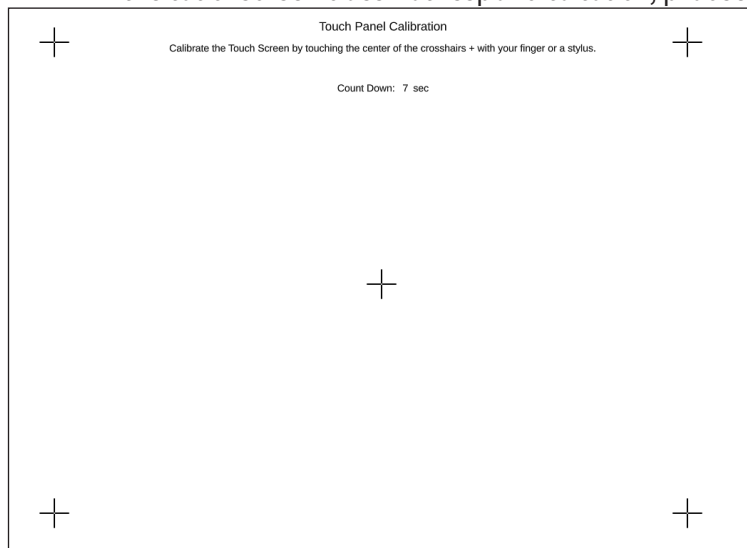

Select Touch Panel Driver

- 1) With a touchscreen connected to the panel, the panel attempts to negotiate the proper driver. If the touchscreen does not respond, the panel may have selected the incorrect driver.
 - The screen below opens.
 - There are up to three Drivers to select, Driver #1, Driver #2 and Driver #3.
- 2) Select each driver in turn and the Check Touch Panel screen opens.

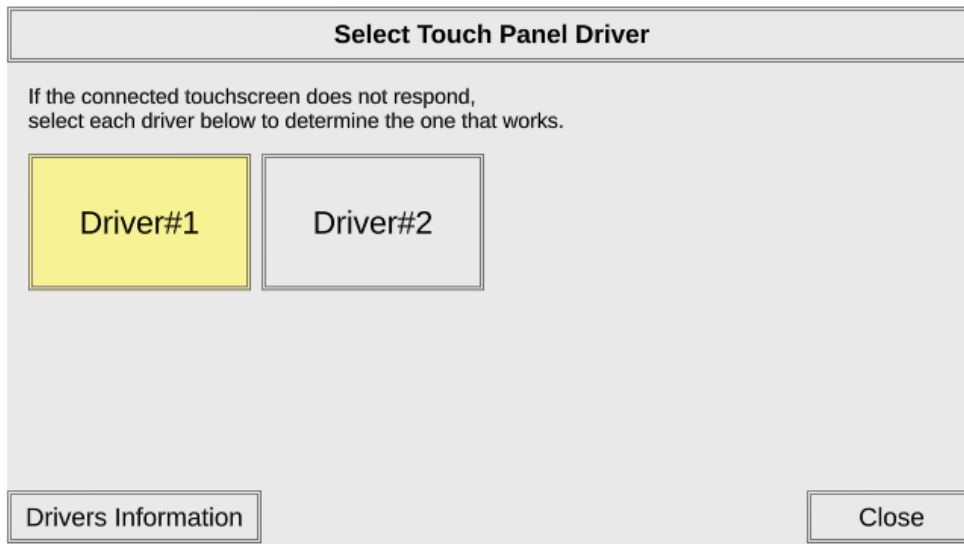

- 3) Touch the screen 3 times within 10 seconds.
 - If the touch is registered, then the driver is used.
 - If the touch is not registered, the screen will timeout.
 - If this occurs, select the next driver and follow the same process.
 - If all drivers have been selected without success, this indicates the panel does not have a driver for the selected touchscreen.

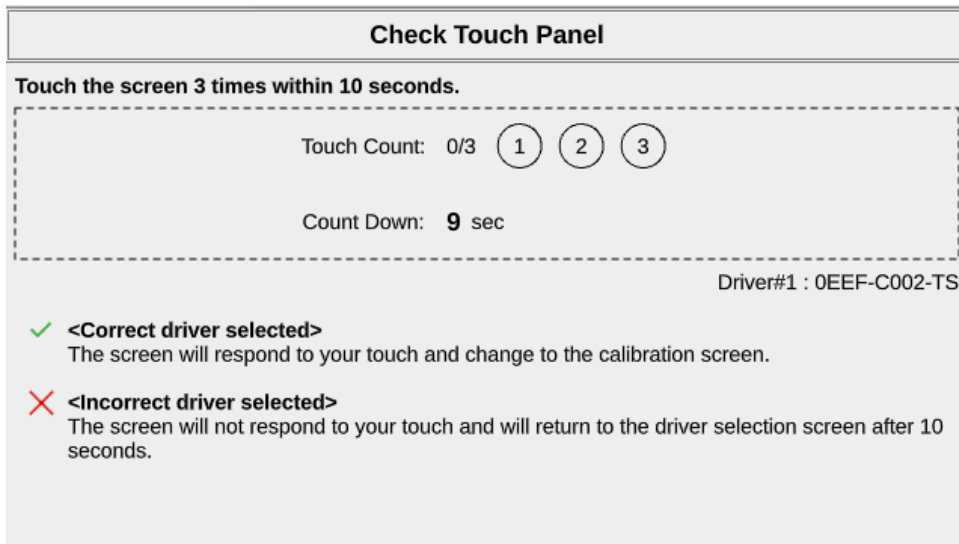

Reporting unsupported driver to AutomationDirect

With the correct driver information, you can attempt add the driver to the panel firmware for a later release.

- 1) Select the Drivers Information button.
 - The Touch Panel Drivers Information window opens as shown below.
- 2) Record the information for all drivers displayed.
- 3) Contact Technical Support and provide this information to them.
 - There is no guarantee the driver can be added, and the time required may not be feasible for your project. You may consider trying a different touch panel monitor.

Touch Panel Drivers Information			
Driver	PID	Vender ID	Type
Driver #1	0EEF	C002	TOUCH SCREEN
Driver #2	0EEF	C002	MOUSE

Settings — Adjust Display

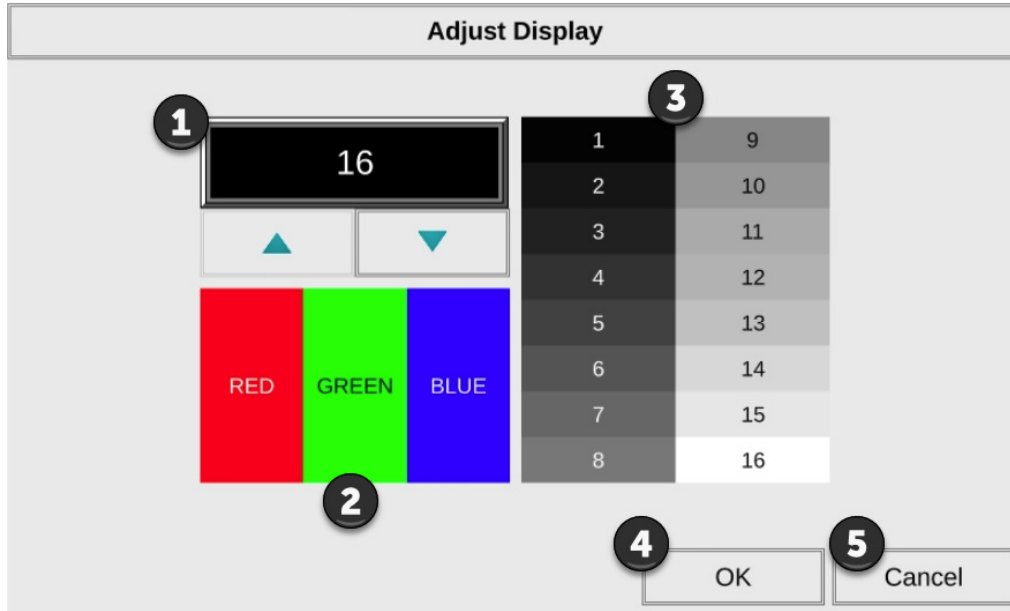

Item No.	Function	Description	Comments
1	Setting	Use the Up and Down arrows to change the brightness.	—
2	Color Sample	Displays a sample of how colors will appear with the new setting	—
3	Contrast Sample	Displays a sample of contrast with the new setting	—
4	OK	Press to accept the changes.	—
5	Cancel	Press to return to the Setting screen without accepting the changes.	—

Settings — Options

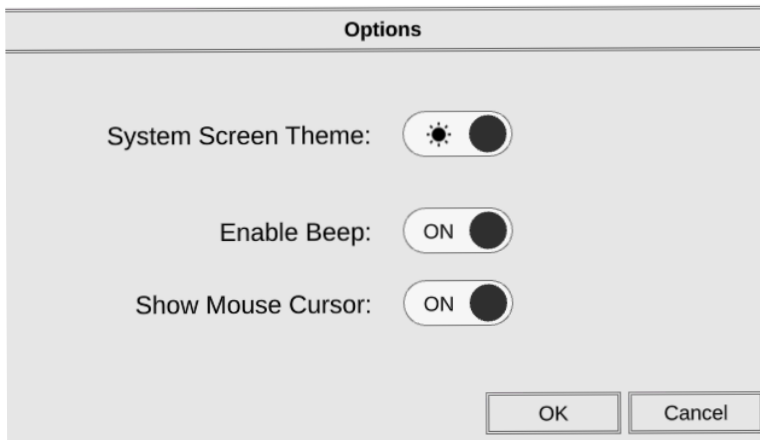

System Screen Theme

This setting is used to select a light or dark theme for the System Screens. This can be useful in very dark or brightly lit situations to help see the screen more clearly.

Enable Beep

This system setup screen function is used to enable or disable the touch panel's internal beep function.

Show Mouse Cursor

This system setup screen function is used to enable/ disable the arrow mouse cursor on the panel screen. It may be valuable to display the mouse cursor, for example, when an external USB keyboard and mouse are connected to the panel.



NOTE: The project settings in the C-more programming software Protocol Manager will override the touch panel's internal setting upon initial download.

Test Menu

The **Test Menu** gives the user the ability to test the operation of the touch screen, test the LCD display, test the various communication ports, and also test the internal beeper and the audio through an user supplied audio adapter and amplified (stereo) speaker(s).

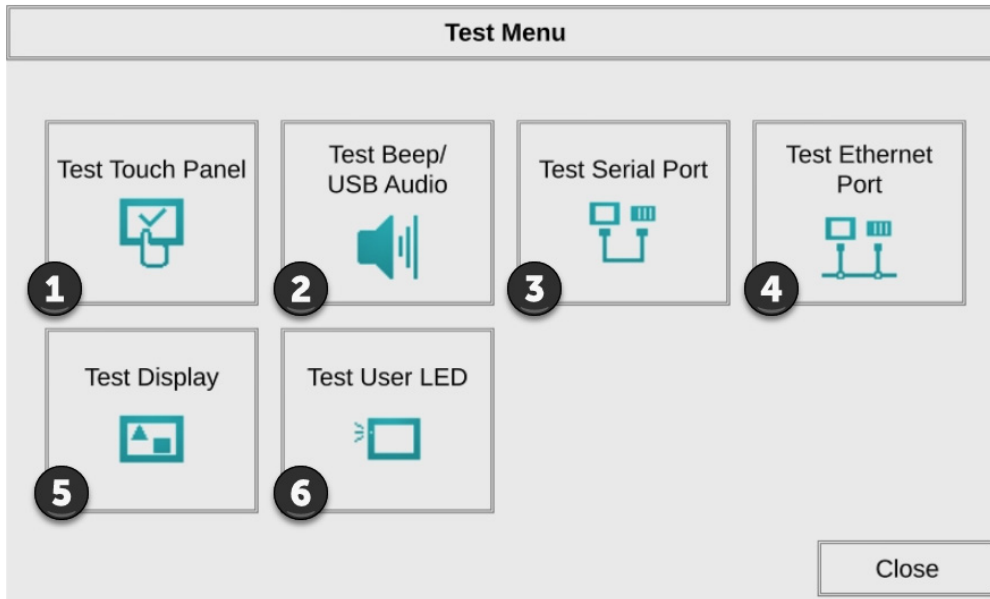

Item No.	Function	Description	Comments
1	Test Touch Panel	Select to test the HMI touch screen functionality and calibration.	—
2	Test Beep Audio	Select to test the HMI beep function or a connected USB to Audio devices.	—
3	Test Serial Port	Select to Test the HMI Serial Ports	—
4	Test Ethernet Port	Select to Test the HMI Ethernet Ports	—
5	Test Display	Select to test the color and contrast of the HMI LCD screen	—
6	Test User LED	Tests the user configurable LED on the front of the panel. Refer to the online help file CM014 User Defined LED for details on the configuration of this LED.	—

Test Menu — Test Touch Panel

Using this test, normal or unusual operation of the analog touch panel can be determined.

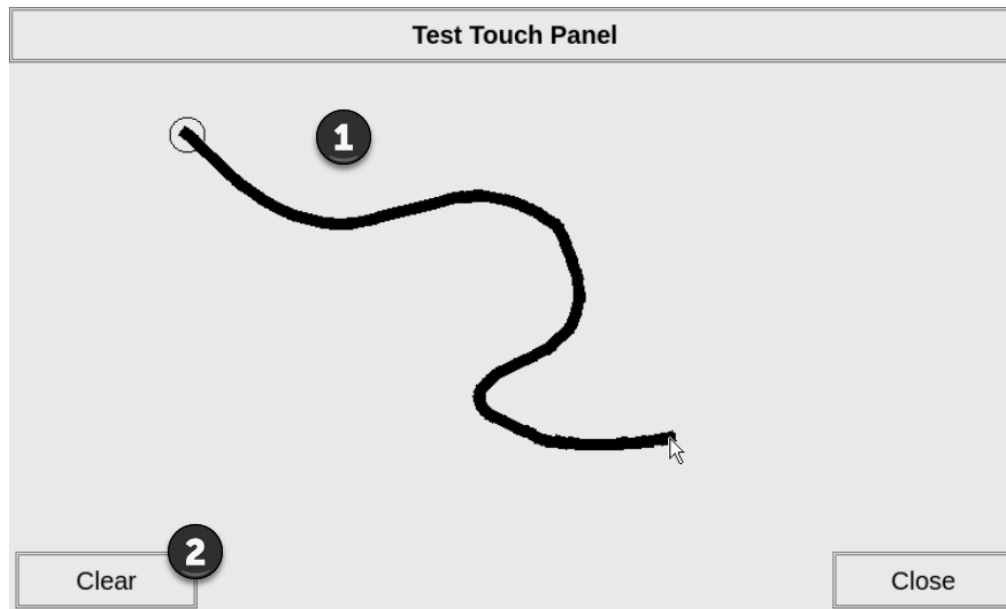

Testing

If an area of the touch screen is suspected to be inoperable, touch or touch and drag that area of the screen. The screen pixels should turn black in that area. If the screen pixels do not turn black when touched, then the touch screen is defective or needs to be calibrated. **See Settings — Touch Panel**

Item No.	Function	Description	Comments
1	Touch Area	Touch to turn on pixels on the screen.	The title bar (Test Touch Panel), Clear and Close button can be drawn across to test the touch operation.
2	Clear	Clear previously highlighted pixels to start over.	—



NOTE: The Touchscreen is designed to respond to a single touch. If it is touched at multiple points at the same time, an unexpected object may be activated.

Test Menu – Test Beep/Audio

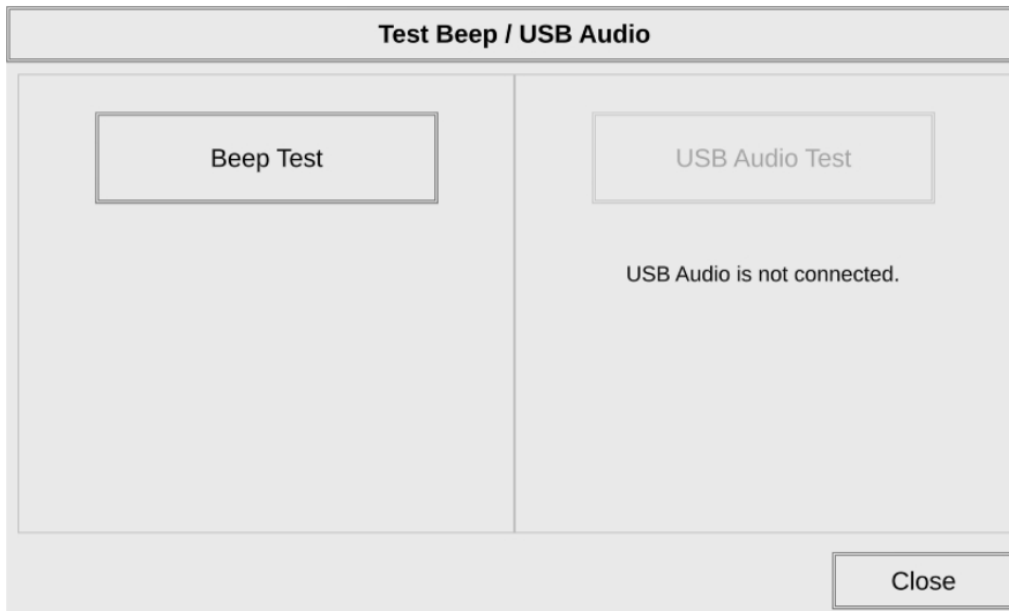

The internal Beeper can be tested from this system setup screen whether the Beeper is enabled or disabled. After the Beep Test button is pressed and released, the Beeper will sound for 500 msec.

The USB Audio Test requires that a USB audio adapter and speaker(s) with an amplifier (can be stereo) be connected to one USB port on the HMI. After the USB Audio Test button is pressed and released, a system provided Test.wav file will play once.



WARNING: Hearing damage may occur if the volume on the user supplied external amplified speaker is set too high.

Test Menu – Test Serial Port

The following test can be used to check the operation of the serial communication ports, with the use of a loop back connector and can also check the serial communications to any connected and configured PLC.

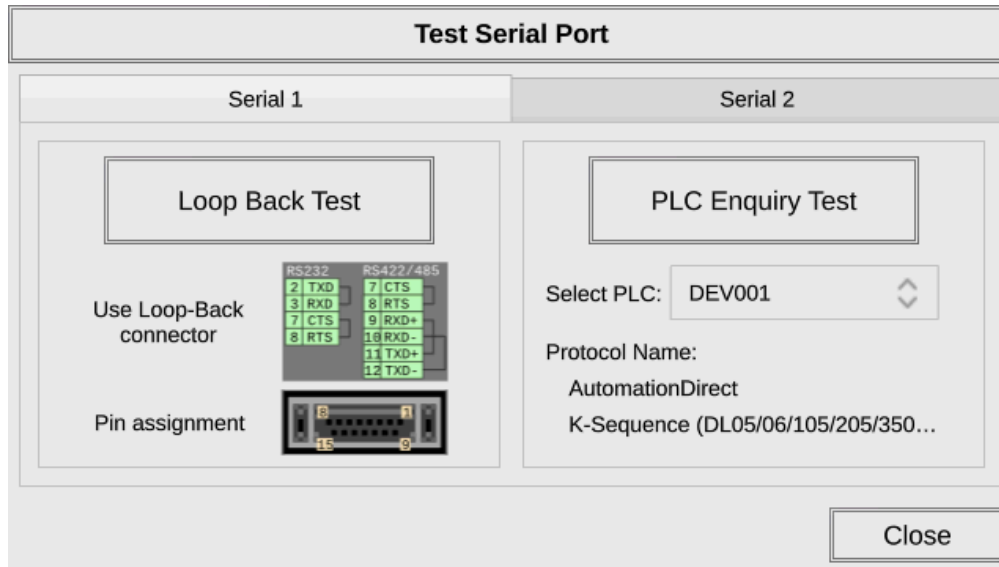

Item No.	Function	Description	Comments
1	Loop Back Test	The loop back test checks the hardware components of the selected port for proper operation.	The loop back test may be performed on Serial Port 1 or Serial Port 2. Each tab shows diagrams to assist the user in building the loop back connector.
2	PLC Enquiry Test	This function allows the ability to select any PLC that may be connected to the touch panel via a serial connection and checks to see if the communications are working correctly.	The PLC must be configured for the selected port in the C-more programming software Protocol Manager and transferred to the panel before attempting the PLC Enquiry test.

Note: Serial 3 on the CM5-T4W and CM5-T7W require a USB to Serial converter, ADC Part No. USB-485M. Otherwise it will show "Not Connected".

Serial Port 1

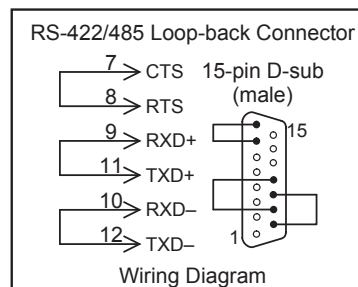
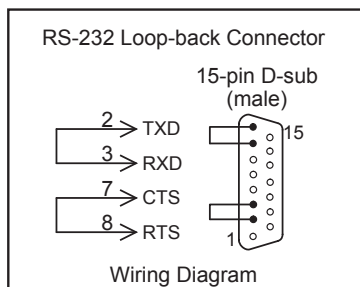

Test Menu – PLC Serial Comm Port - Loop back test

Test Results

Bytes Sent:

The number of bytes sent after a test is started.

- 1) Receive Counts:
The number of bytes which are received after the test is started.
- 2) Error Counts:
The number of bytes which have not been received after the test is started.
- 3) RTS/CTS Test: Pass/Fail
RTS is turned on and if CTS receives the signal then the test shows “Pass”, otherwise the test shows “Fail”.



NOTE: The test will continue to run until the Cancel button is pressed. If there are any error counts, check the loop back connector.

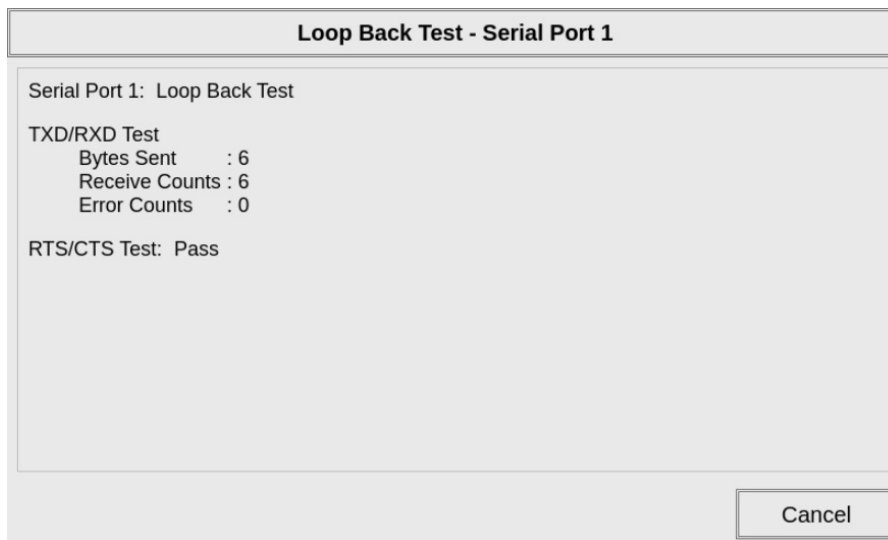

Test Menu — PLC Enquiry Test: Serial Connection

This function allows the ability to select any PLC that may be connected to the touch panel through the selected serial comm. port connection and checks to see if the communications are working correctly.



NOTE: The communications protocol for the selected PLC must match the the C-more touch panel. The touch panel PLC serial communications are configured using the C-more Programming Software's Protocol Manager.

PLC Enquiry Test

Four test packets are sent to the selected PLC. The test result with return either Pass or Fail.

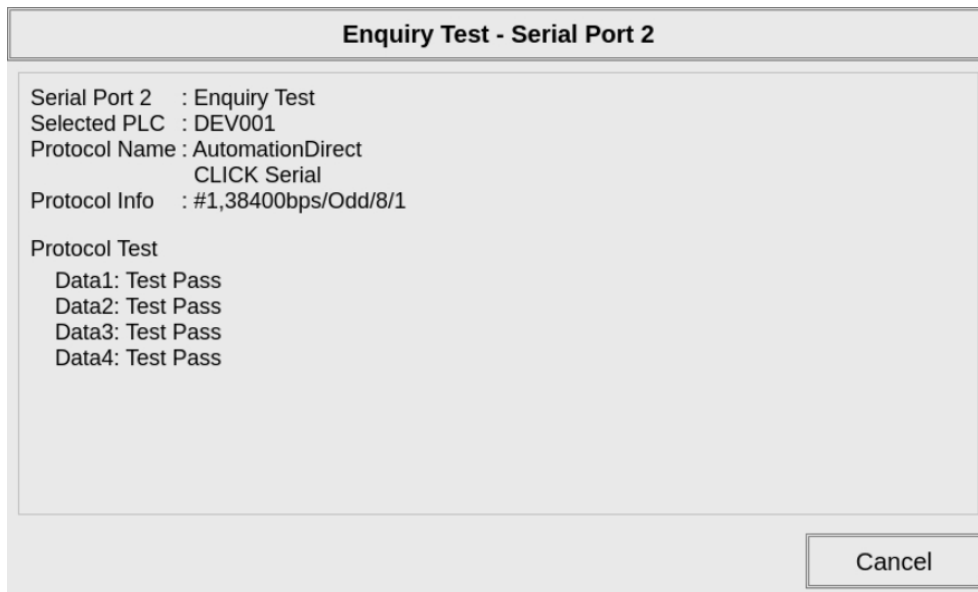

Test Menu – Test Ethernet Port

The following test feature can be used to check the operation of the Ethernet communication port by indicating if an Ethernet link has been established or not, and can also check the status of the Ethernet communications to any connected PLC.

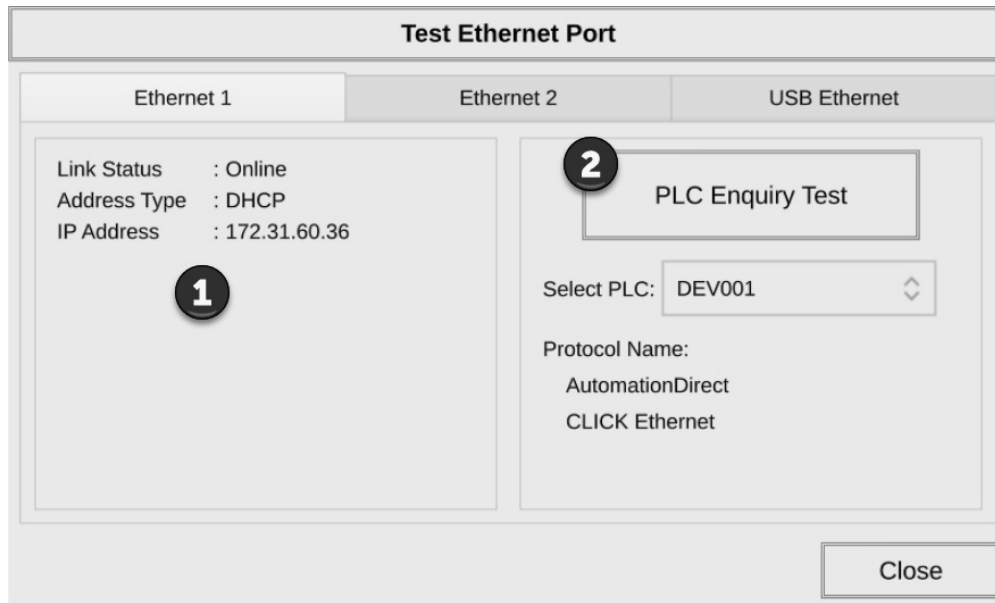

NOTE: The communications protocol for the selected PLC must match the the C-more touch panel. The touch panel PLC serial communications are configured using the C-more Programming Software's Protocol Manager.

Item No.	Function	Description	Comments
1	Connected	This area displays information to whether an Ethernet link has been established for the touch panel's Ethernet comm port or not. Displays panel's IP address and shows whether it is static or assigned by a DHCP server.	Ethernet 2 is not supported on the CM5-T4W and CM5-T7W. USB Ethernet requires a USB to Ethernet converter. Otherwise it will show "Not Connected".
2	PLC Enquiry Test	This function allows the ability to select any PLC configured in the project that may be connected to the touch panel via an Ethernet connection and checks to see if the communications are working correctly.	The PLC must be configured for the selected port in the C-more programming software Protocol Manager and transferred to the panel before attempting the PLC Enquiry test.

Test Menu — PLC Enquiry Test: Ethernet Connection

PLC Enquiry Test

Following are the steps that the Ethernet PLC Enquiry Test performs:

- 1) Ping the network 4 times for the PLC selected.
- 2) Four of the test read packets are sent to the selected PLC.

The test result will either be Pass or Fail. However, if the result of pinging the network shows an error.

Enquiry Test - Ethernet Port 1

Ethernet Port 1: Enquiry Test
 Selected PLC : DEV002
 Protocol Name : AutomationDirect
 CLICK Ethernet
 Protocol Info : 192.168.1.32

Ping Test	Protocol Test
Data1: Reply from PLC bytes=64, time=0.528ms, TTL=64	Data1: Test Pass
Data2: Reply from PLC bytes=64, time=0.231ms, TTL=64	Data2: Test Pass
Data3: Reply from PLC bytes=64, time=0.225ms, TTL=64	Data3: Test Pass
Data4: Reply from PLC bytes=64, time=0.298ms, TTL=64	Data4: Test Pass



NOTE: The communications protocol for the selected PLC must match the the C-more touch panel. The touch panel PLC serial communications are configured using the C-more Programming Software's Protocol Manager.

Test Menu – Test Display

There are two different test patterns that may be run on the display to allow the user to check for display screen defects. If the screen is not touched within 3 seconds of Test Pattern 1 being displayed, then Test Pattern 2 will be displayed until the screen is touched, otherwise Test Pattern 1 will remain until closed. Press Test LCD to begin the test.

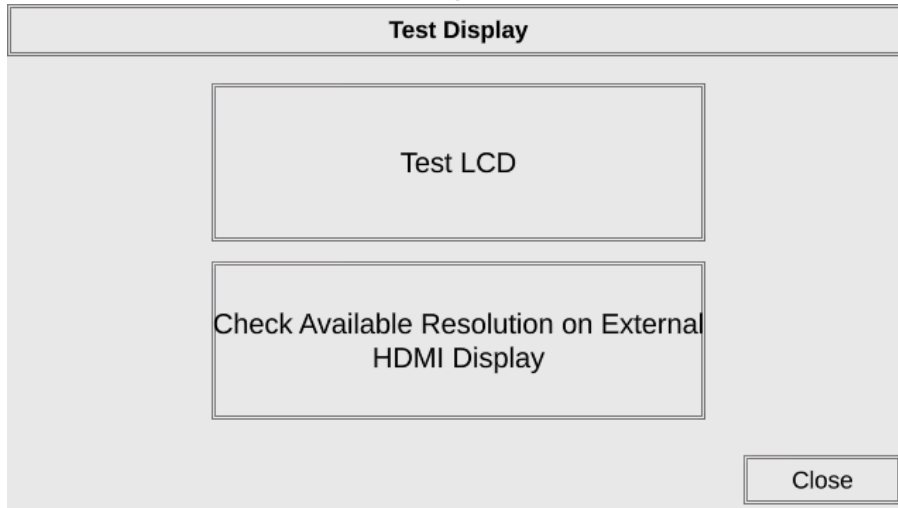

Test Pattern 1 displays a test pattern of 16 grayscale graduations and RGB colors.

Test Pattern 2 will follow the pattern as shown in the following chart with the color wiping across the screen in the direction indicated by the arrows, then repeats:

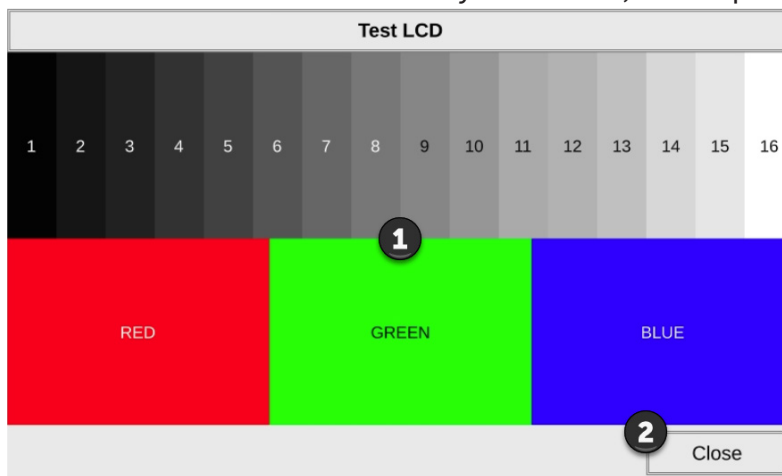

Color	1st Time	2nd Time	3rd Time	4th Time
Red	→	↑	↓	←
Green	←	→	↑	↓
Blue	↓	←	→	↑

Item No.	Function	Description	Comments
1	Touch the Test Display screen.	Press the screen anywhere except the Close button and the shown Test Pattern 1 remains.	If the Test Display screen is not touched, then in three seconds the display will move to Test Pattern 2.
2	Close (Test Pattern 1)	Press to return to the Test Menu	
3	Touch Anywhere (Test Pattern 2)	Touch the screen anywhere during Test Pattern 2 and return to the Test Display Menu.	

Test Results: If any pixels on the screen do not appear the same color as the surrounding pixels, the screen may be defective. A single pixel gone bad is relatively common. Surrounding pixels going bad over time is another indication the screen may be defective.

Check Available Resolutions on External HDMI Display

This selection performs a check through the HDMI port and attempts to negotiate with a



NOTE: If the display is connected through a signal converter such as an HDMI-DVI converter, the negotiations may not be successful and the available resolutions may not be correct.

connected display and determine all available resolutions.

Check Available Resolution on External HDMI Display

Panel has detected an HDMI display with following available resolutions. Check if your selected resolution is fully and properly displayed on the HDMI Monitor.

Note: When using a signal converter such as an HDMI-DVI Converter may affect results.

- ✓ VGA (640x480,60Hz)
- ✓ XGA (1024x768,60Hz)
- ✓ SD 480P (720x480,60Hz)
- ✓ HD 720P (1280x720,60Hz)
- ✓ FHD 1080P (1920x1080,60Hz)

Test Menu – Test User LED

The user defined LED on the panel front bezel can be controlled from the project to illuminate red, green, or orange. It can also be configured to blink these colors. Refer to the online help file provided with the programming software for details. The System Screen can also be used to verify that the User Defined LED is functioning.

User Defined LED (Green, Orange & Red)	
Off	User Defined (Refer to online help file for further details)
Green	
Red	
Orange	
Blinking Red	
Blinking Orange	
Blinking Green	

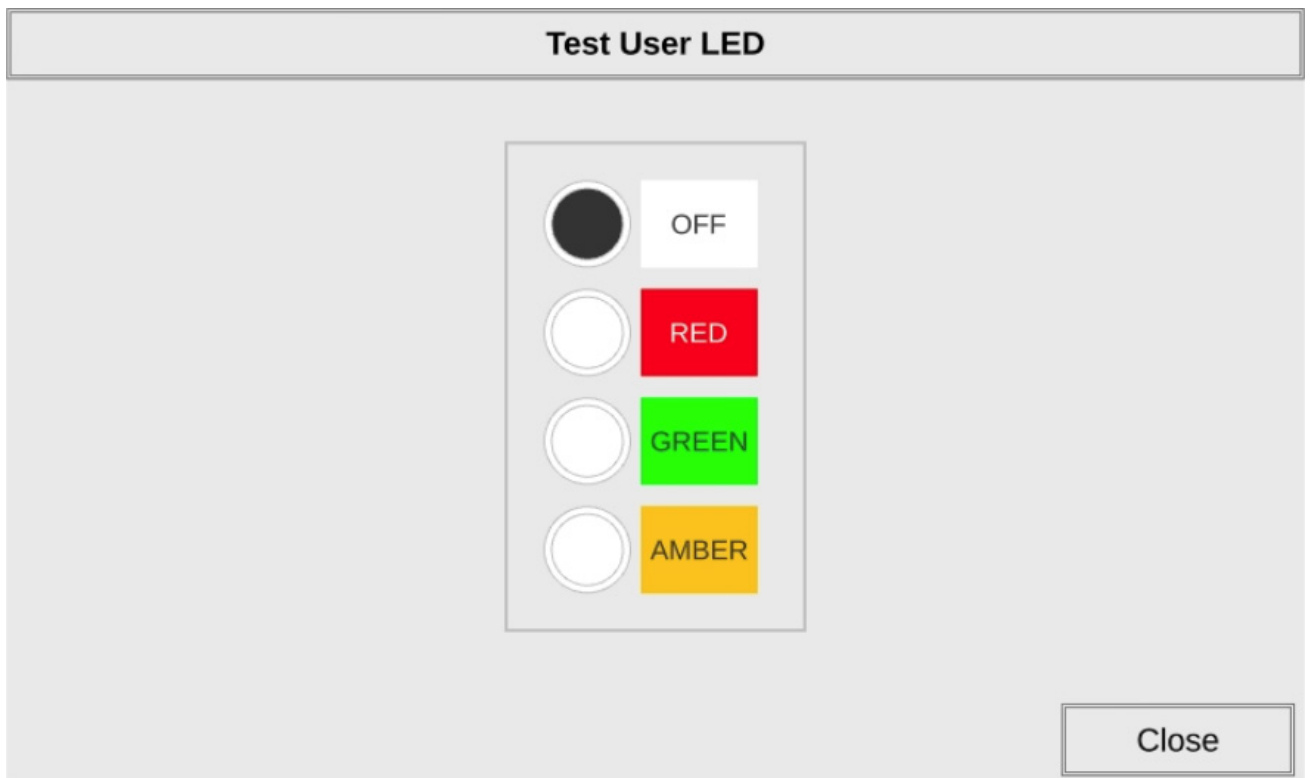
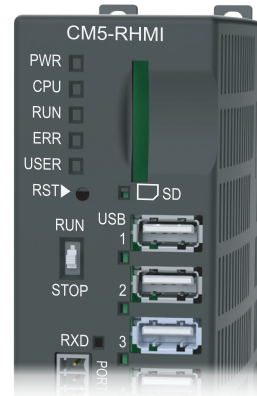

NOTE: CM5-T4W doesn't have a User Defined LED.

Memory Screen

The **C-more** CM5 panel project, Firmware and OS, log and recipes files can be backed up to or restored from an SD memory card or a USB memory device. From this screen the user can also clear the project log files. The user also has the ability to clear any memory or memory device in the **C-more** touch panel.

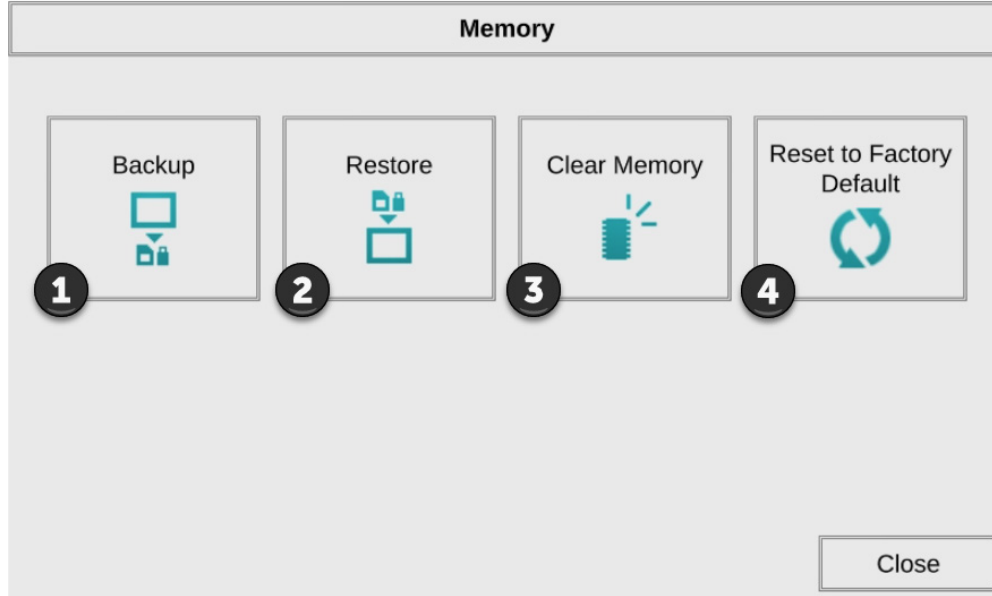

Item No.	Function	Description	Comments
1	Backup	Backup project, Firmware and OS, logs & recipe files to the following memory devices: USB port - Type A: USB pen drive SD Card Slot1:SD Card	Any USB 2.0 pen drive. SD formats SD , SDHC and SDXC are supported. Capacity up to 32 GB. The backup data files are created and copied to a folder on the memory device named "CM_MemoryCopy." The project file is named StartupStorage.easv "Log" and "Recipe" folders with the appropriate data files are also created on the memory device.
2	Restore	Restore project, Firmware and OS, log & recipe files to the internal memory from one of the following memory devices: USB port - Type A: USB pen drive SD Card Slot1:SD Card	A folder on the memory device named "CM_MemoryCopy" must exist containing a file named "StartupStorage. easv". The project data file is stored in this file, and if the system data file was backed up, it also will be stored in this file. Any backed up log or recipe data files will be located under the appropriate "Log" or "Recipe" folders.
3	Clear Memory	Clear selected data files from the memory of the following internal memory or external memory devices: Built-in FLASH Memory USB port - Type A: USB pen drive SD Card Slot1:SD Card	Can only clear project, log and recipe data files of the Built-in FLASH memory. Can clear entire contents or individual data files of external memory devices.
4	Reset to Factory Default	The touch panel's internal memory is set to the original factory defaults.	Clears all project memory and other settings to factory original settings.

Saving to an External Memory Device

The project is RESTORED to the panel from an external memory device. A project can be TRANSFERRED to an SD card or USB memory from the programming software by saving to an External Memory Device. Then the project can be RESTORED to a panel that is not connected to the programming software. This file has the .easv extension NOT the .eapv extension of a project SAVED from the software.

Increasing Project Memory Size using an SD memory card

If a project is transferred to the panel with an SD memory card in SD slot, the Font and Recipe data files are not included in the 45MB project size. Therefore using an SD memory card can allow a project to be loaded that is larger than project storage memory of the panel if the excessive size is caused by Fonts and/or Recipe Sheets.

Memory — Backup

The Memory - Backup selection allows you to backup the panel’s Project, Log files, Recipe files or even the Firmware files to either an SD memory card or USB pen drive. The available memory devices will be displayed with their total and free memory. If the device is not available, it will be grayed out. The Next >> button is grayed out until a device is selected. The Cancel button can be pressed at any time to return to the Memory Screen.

Below is an example of selecting a USB memory device to write the backed up files to. The selected device is highlighted. Pressing again deselects it. Even if there is only one available memory device, it still needs to be highlighted in order to go to the next step.

Press the Next >> button to continue to Step 2.

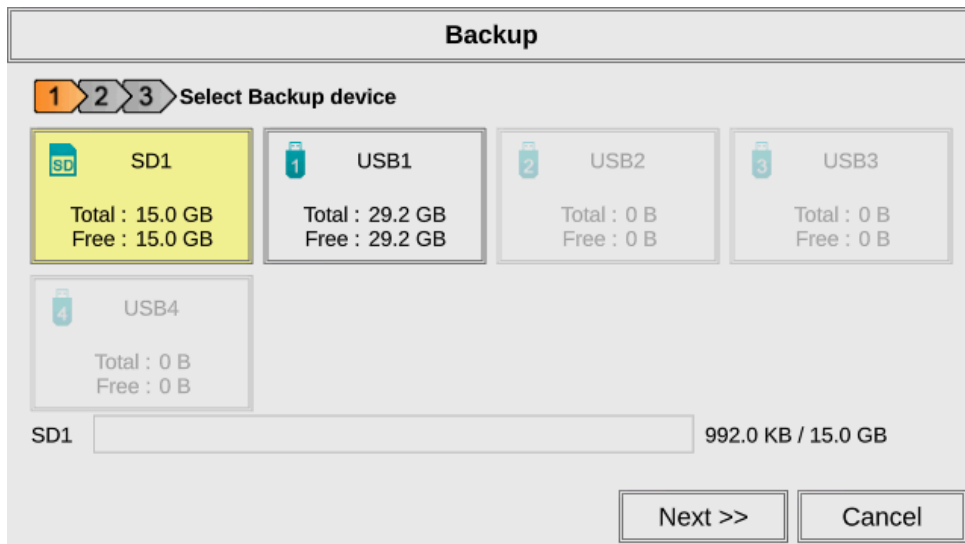
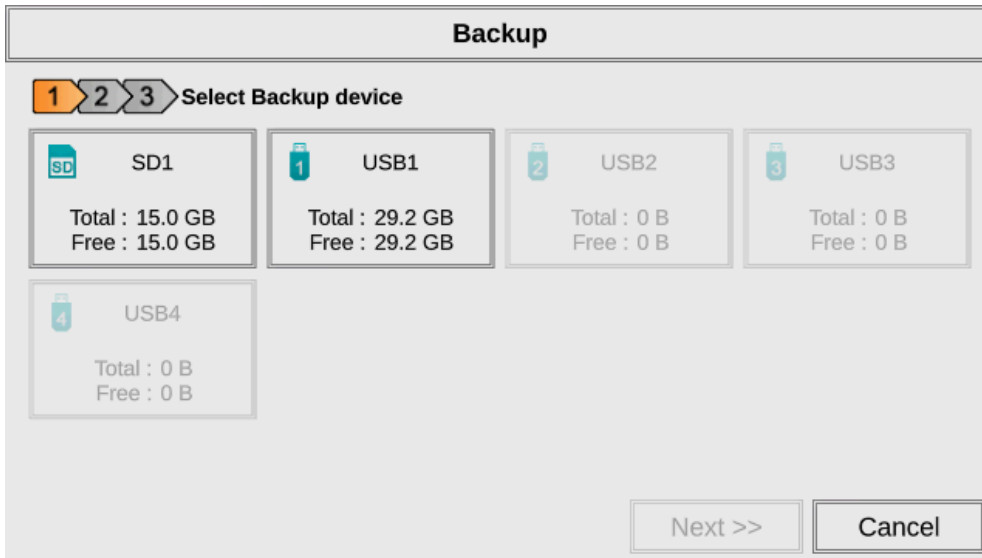

SD1 Availability

SD1 may be unavailable (grayed out) if there is no card in the SD Slot or the card in the SD slot has the project currently running on the panel stored on it. The project will reside on the SD Card if the Project Storage/Boot Location is set to Auto or SD1 in the **C-more** software Protocol Manager, and an SD memory card is located in the SD Card Slot 1 at the time a project is transferred to the panel

Select the data file(s) to be backed up by pressing the appropriate data file button. The selection will be highlighted.

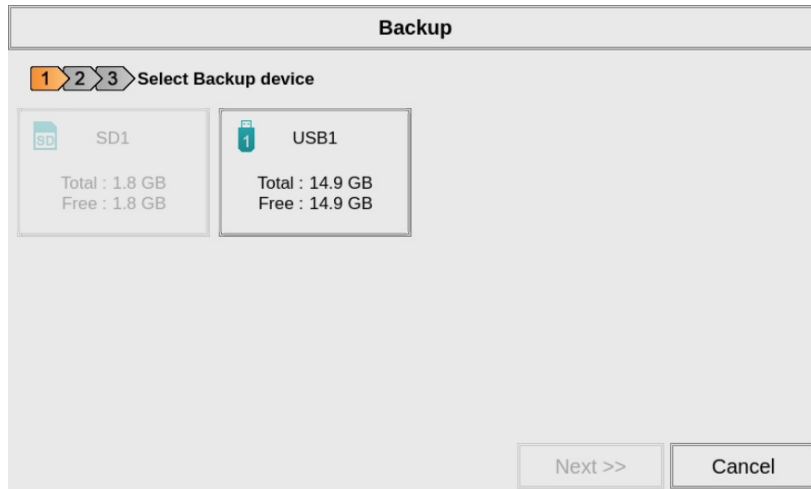

NOTE: The following definitions are for the various file types that can be backed up:

Firmware – consists of the operating system, firmware and run time files. Included in backup file name StartupStorage.easv.

Project data – consists of the actual developed project data that is created in the C-more programming software and includes all functionality, objects, screens, tag names, labels, comments, graphics, etc. Included in backup file name StartupStorage.easv.

Recipe data – consists of all the data values and labels that have been created for the various recipe sheets. Includes all recipe sheets loaded to the panel. Only recipe sheets used in the project are loaded to the panel.

Pressing the highlighted data file button again will turn it off. The Next >> button will stay grayed out until at least one data area is selected. Any file type not available will be grayed out.

Press the Next >> button to continue.

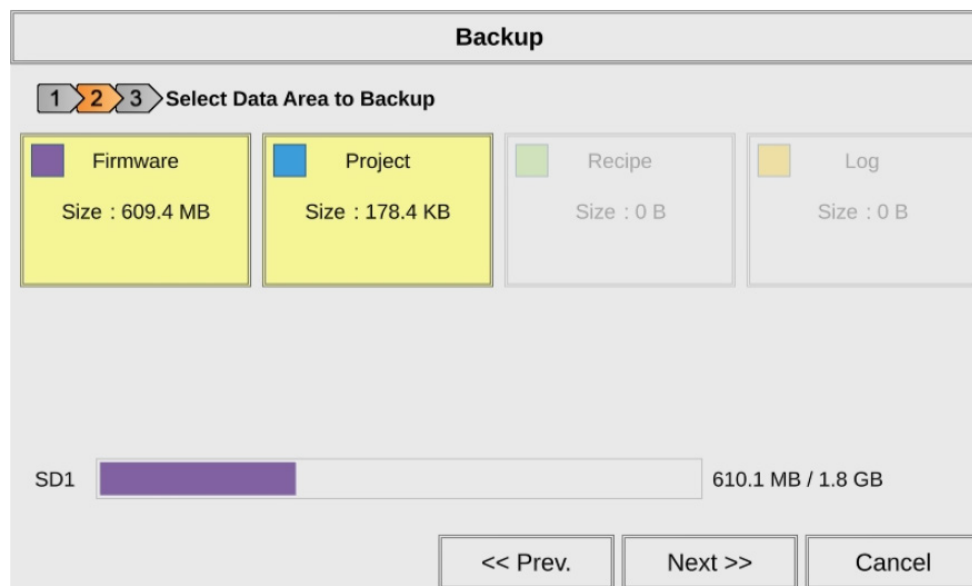

Backup Data Files Naming and Organization



*NOTE: In the case of the Project and Firmware files, these can be Restored later to another panel.
 Recipe files can be edited externally from the panel and then Restored to the panel.
 The Log files are for viewing purposes only.
 See **Memory - Restore** later in this chapter for instructions on Restoring the Project, Firmware and or Recipe files to a Panel.*

The following graphic shows how the various data files are organized on the memory device when doing a Backup and also the file naming convention that is used when viewed in Windows® File Explorer on a PC.

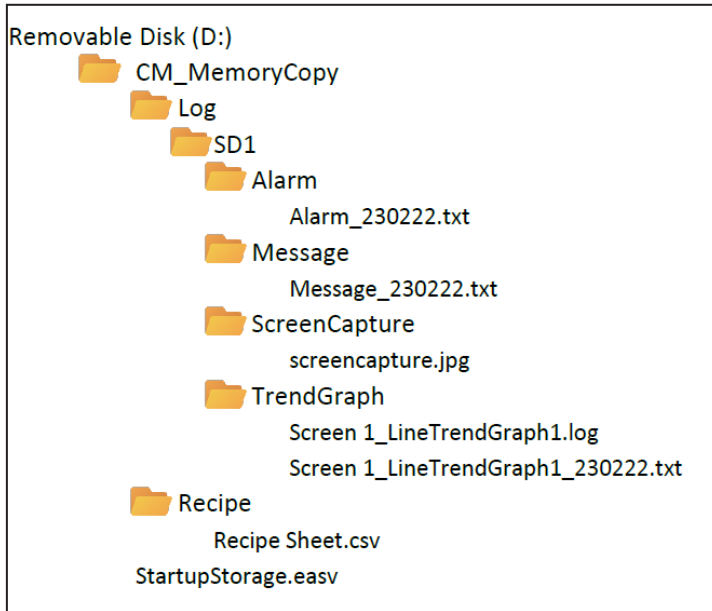

The next system setup screen allows the verification of the data file and backup device selections. When the OK button is pressed, a last verification popup is displayed.

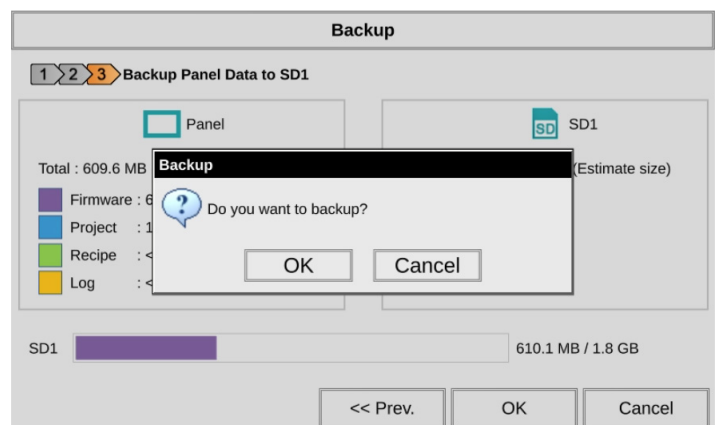
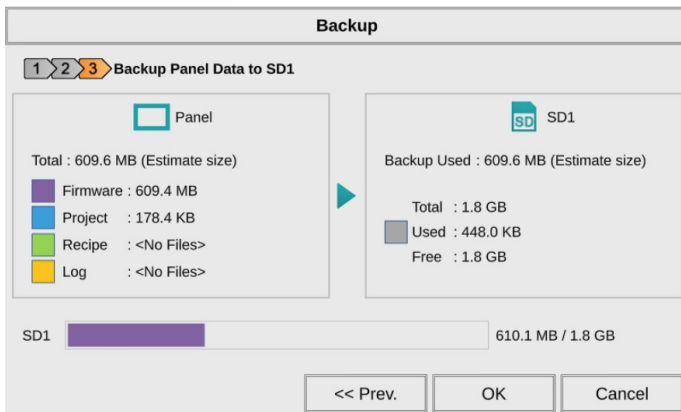

The following text is shown in the copying progress message box. This message is displayed during the Backup copying process.

Do not remove power
Do not remove [%device%]
 %device% will show either **SD1, USB1, USB2, or USB3.**

The backup process will take several minutes if backing up firmware. This message is displayed to indicate the backup is complete.

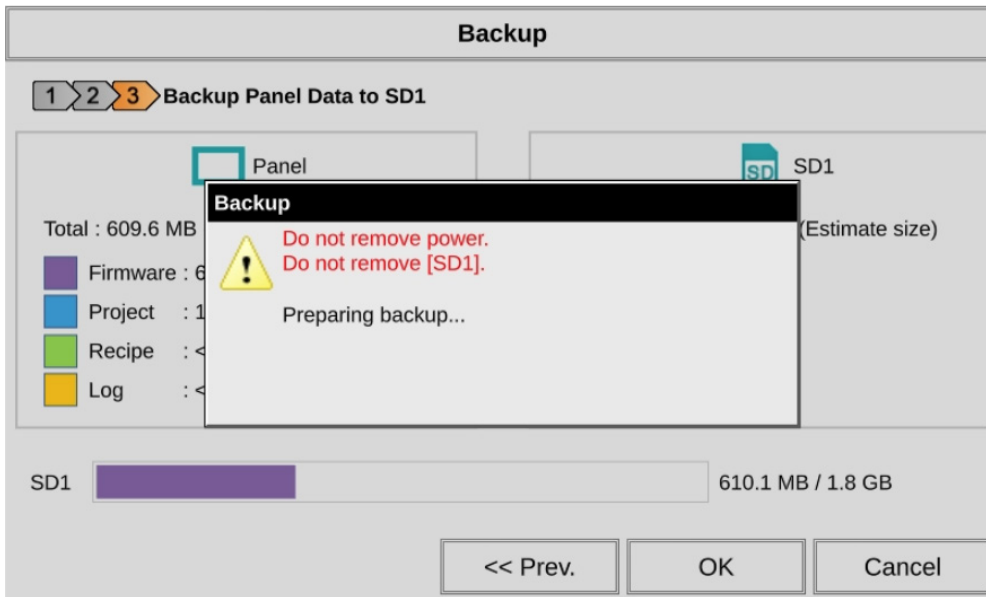

WARNING: During the backup process do not power off the touch panel or remove the memory device.

Press the OK button to return to the previous screen selection.

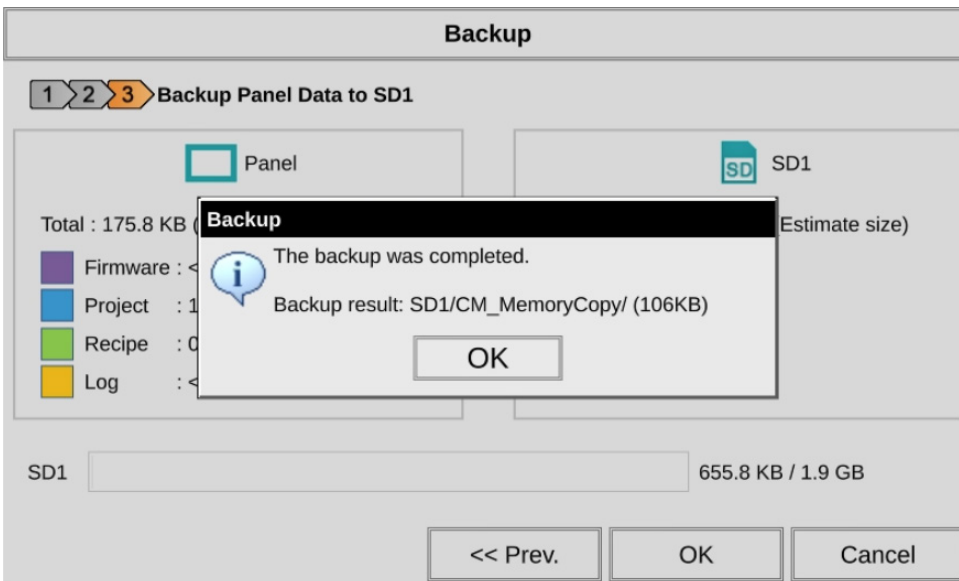

Backup Warning Messages

If the destination does not have enough space to store the selected memory size, then the message shown here will be displayed. Press the OK button to clear the warning message.

The warning message will read:

[SSC-300] %device% does not have enough free space. Please use a [device type] with more space.

%device% and [device type] will show either **SD1, USB1, USB2, or USB3.**



This warning message will be displayed if the backup Memory device fails or is removed during the backup. Press the OK button to clear the warning message. The warning message will read:

[SSC-306] Backup Failed. %device% cannot be found.

%device% will show either **SD1, USB1, USB2, or USB3.**



Refer to **Chapter 8: Troubleshooting** and **Appendix C: System Screen Error Codes** for additional help.

Memory — Restore

The Memory - Restore function is used to:

- 1) Restore a project previously backed up on an SD card or USB pen drive memory device to the same panel. See **Memory — Backup** previously in this chapter.
- 2) Copy a project from one panel to another panel using a memory device to physically transport the data files.
- 3) Restore a project into the panel that was transferred to an “External Memory Device” using the **C-more** Programming Software.
- 4) Restore Recipe Sheet(s) previously backed up to a memory device or copied to the memory device using a PC.

The available memory devices will be displayed showing the total and free available memory for that device. If the device is not available, it will be grayed out. The Next button is grayed out until a device is selected.

Below is an example of a SD card memory device selected to be the source for restoring the data file(s). The selected device is highlighted. Pressing again deselects it. Even if there is only one available memory device, it needs to be highlighted in order to go to the next step.

Press the Next >> button to continue.



NOTE: If you have a memory device inserted into the proper port on the touch panel, but it doesn't show up as highlighted in Step 1 of the Restore screen, then try a different device to determine if the memory device is defective or if there is a possible problem with the memory device connection. It may not be compatible with the panel. Some USB pen drives are not USB 2.0 compatible and will not work with C-more touch panels. Some SD cards must be formatted using the SD formatter provided by SDcard.org



NOTE: The following definitions are for the various file types that can be restored:

Firmware – consists of the operating system, firmware and run time files. Included in backup file name StartupStorage.easv.

Project data – consists of the actual developed project data that is created in the C-more programming software and includes all functionality, objects, screens, tag names, labels, comments, graphics, etc. Included in backup file name StartupStorage.easv.

Recipe data – consists of all the data values and labels that have been created for the various recipe sheets. Includes all recipe sheets loaded to the panel. Only recipe sheets used in the project are loaded to the panel.

Select the data file(s) to be restored by selecting the appropriate data area button. The selection will be highlighted. The data area can either be the Project, Recipe files and/or the Firmware. If the backup file was made using the software and transferring to External Memory Device, and the Project Storage/ Boot Location setting in the project Panel Manager determines the restoration location. See the Help File Panel Manager topic.

If the backup file was made using the System Setup Screens then the restoration point is the same as the projects boot destination. Pressing the highlighted data area button again will turn it off. The Next >> button will stay grayed out until at least one data area is selected. Any file type not available will be grayed out.

The selected file is highlighted. Pressing Cancel will return to the Memory screen. Pressing the << Prev button with return to the previous screen. Press the Next >> button to continue.

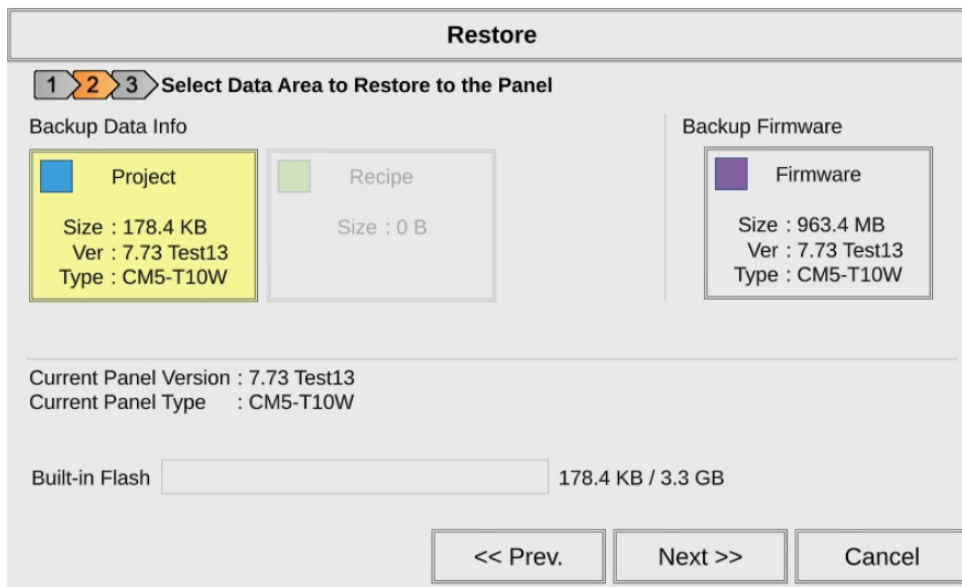

NOTE: The following definitions are for the various file types that can be restored:

Project data – consists of the actual developed project data that is created in the C-more programming software and includes all functionality, objects, screens, tag names, labels, comments, graphics, etc. Included in backup file name StartupStorage.easv.

Recipe data – consists of all the data values and labels that have been created for the various recipe sheets. Includes all recipe sheets loaded to the panel. Only recipe sheets used in the project are loaded to the panel.

Firmware – consists of the operating system, firmware and run time files. Included in backup file name StartupStorage.easv.



The next window shows what has been selected and the operation that is carried out.

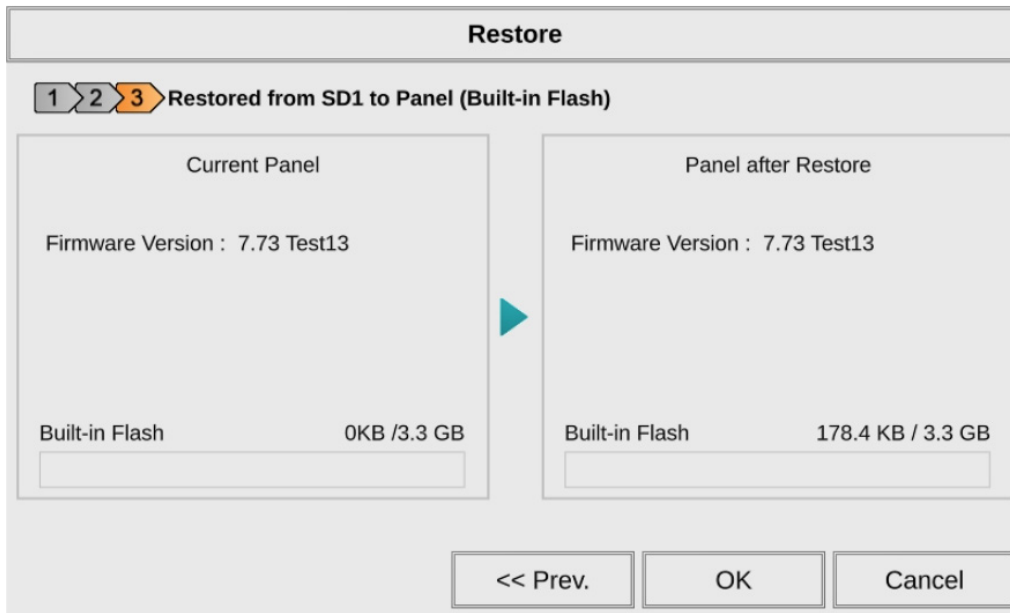

The following text is shown in the copying progress message box:

Do not remove power
Do not remove [%device%]
 %device% will show either **SD1**, **USB1**, **USB2**, or **USB3**.

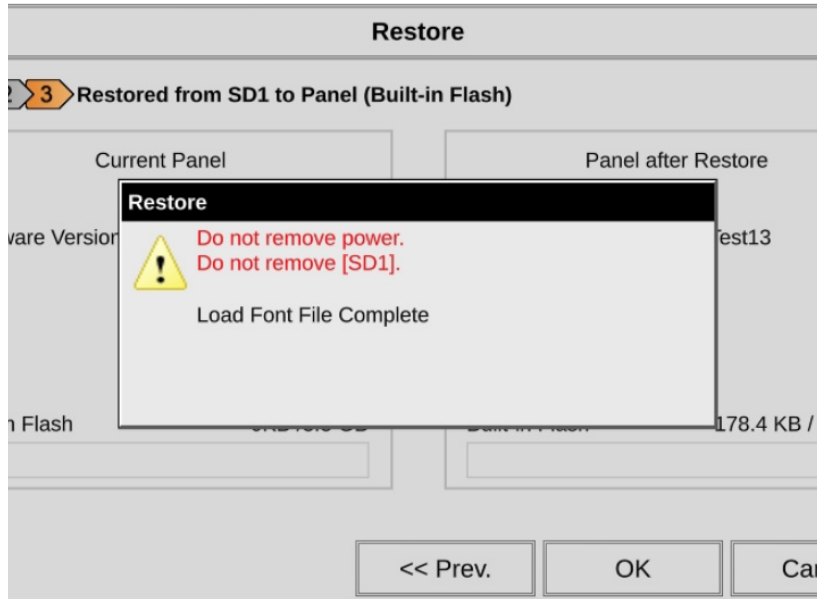

WARNING: During the restore process do not power off the touch panel or remove the memory device.

The message below is displayed momentarily to indicate the Restore is complete. The panel will reboot automatically and run the restored project or data.

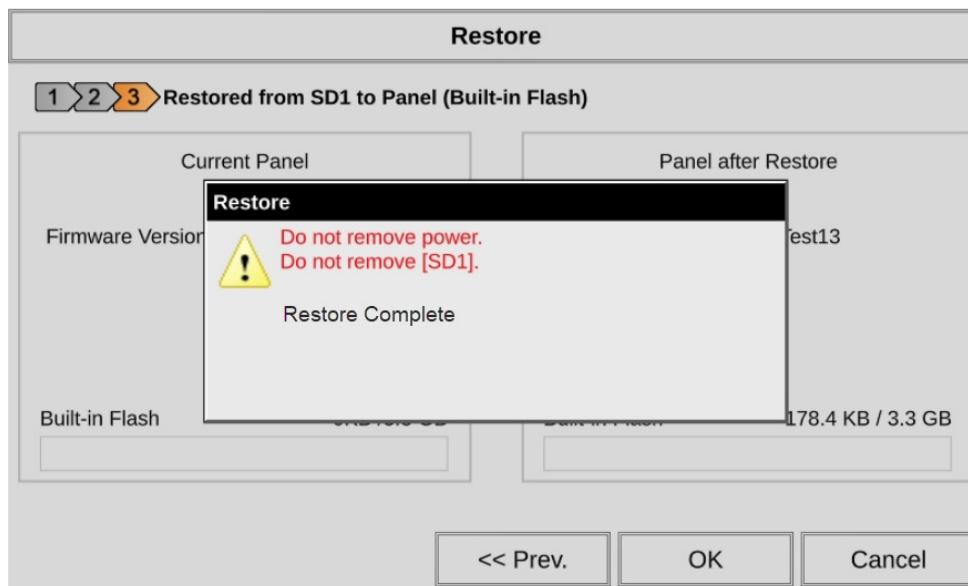

Memory — Clear Memory

This function is used to clear individually selected data files, or all data files, within the panel’s built-in memory, or any installed memory device such as a USB pen drive or an SD card. Select the memory device to clear. If the device is not available, it will be grayed out. The Next >> button is grayed out until a device is selected.

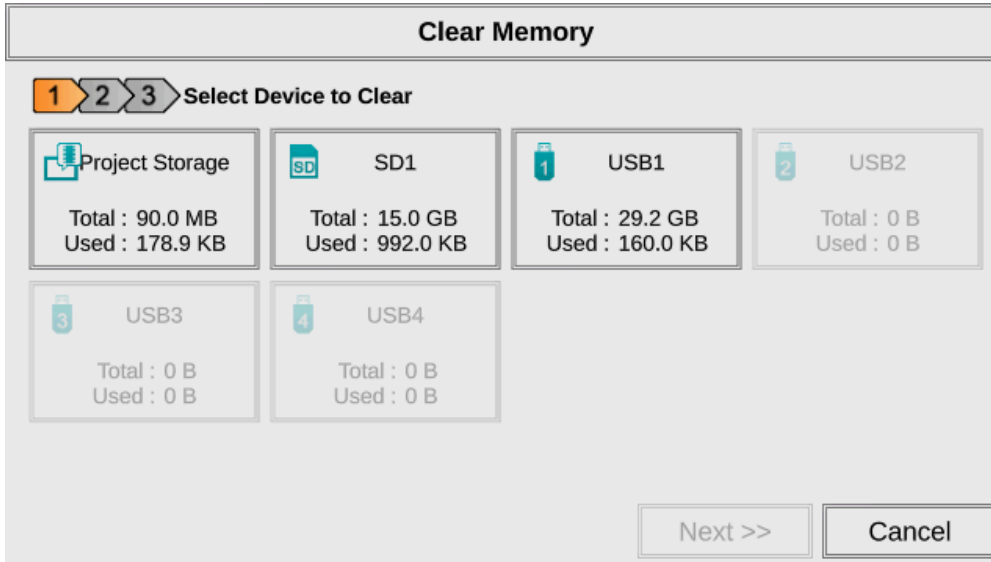

The selected device is highlighted. Pressing again deselects it. When there are more than two available backup devices, only one can be selected at a time.

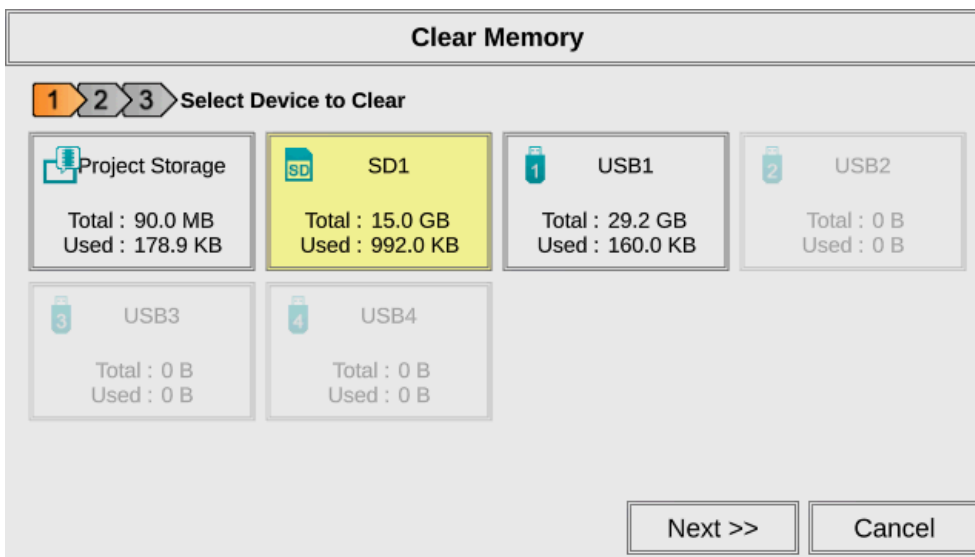

Press the Next >> button to continue.

Select the data area to be cleared. The Next >> button will stay grayed out until an area is selected. Selecting Clear All will erase all files located on the memory device.

The selected memory is highlighted. Pressing again deselects it. Pressing Cancel will deselect the file(s) and return to the Memory screen.



NOTE: Firmware files cannot be cleared from internal memory.

Press the Next >> button to continue.

The next window shows what has been selected and the operation that will be carried out.

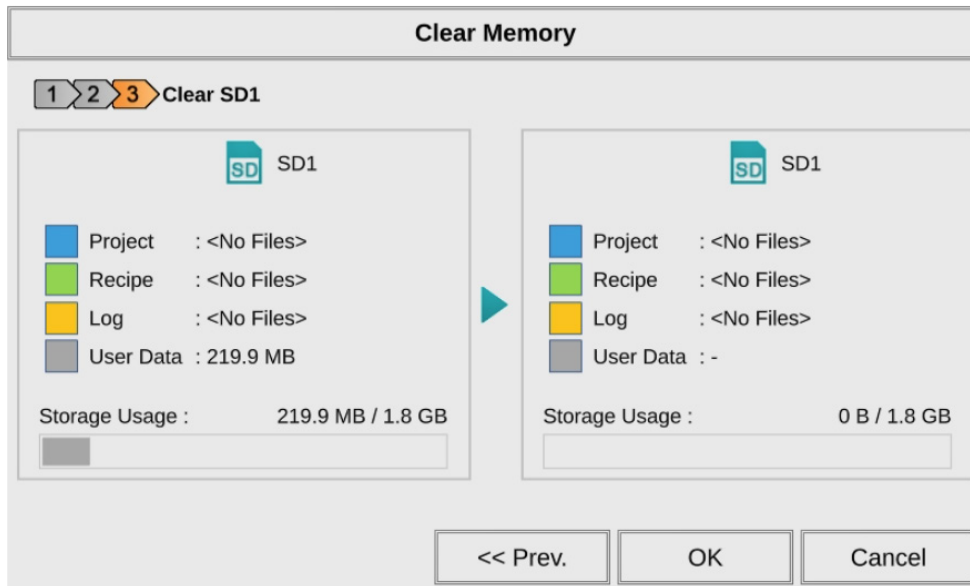

Press the OK button to continue.

Select OK to begin clearing the memory at the desired location(s). Select Cancel to return to the previous screen.

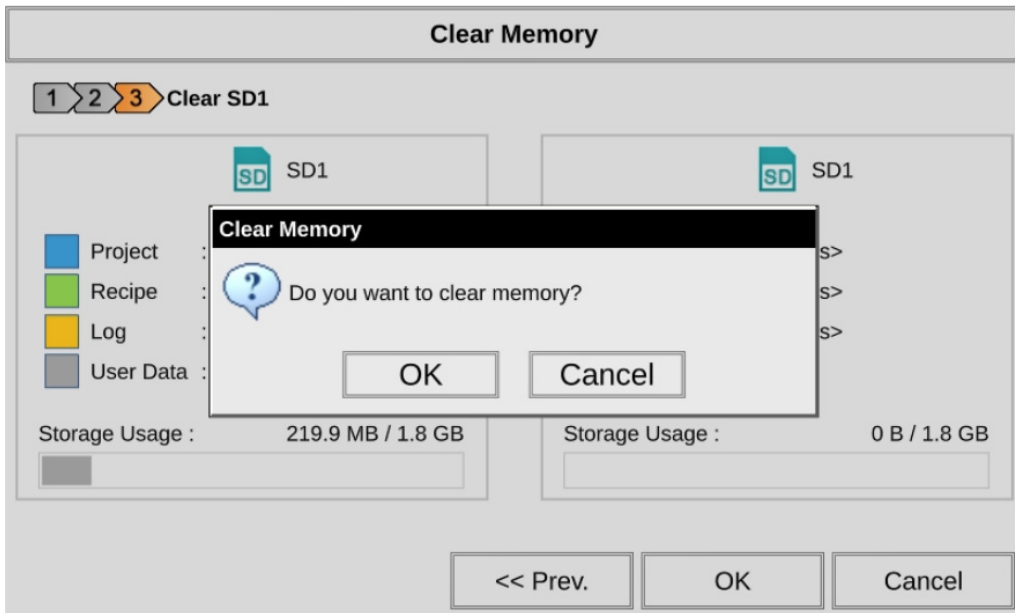

After the Clear Memory process is complete, press OK to return to the Memory screen.

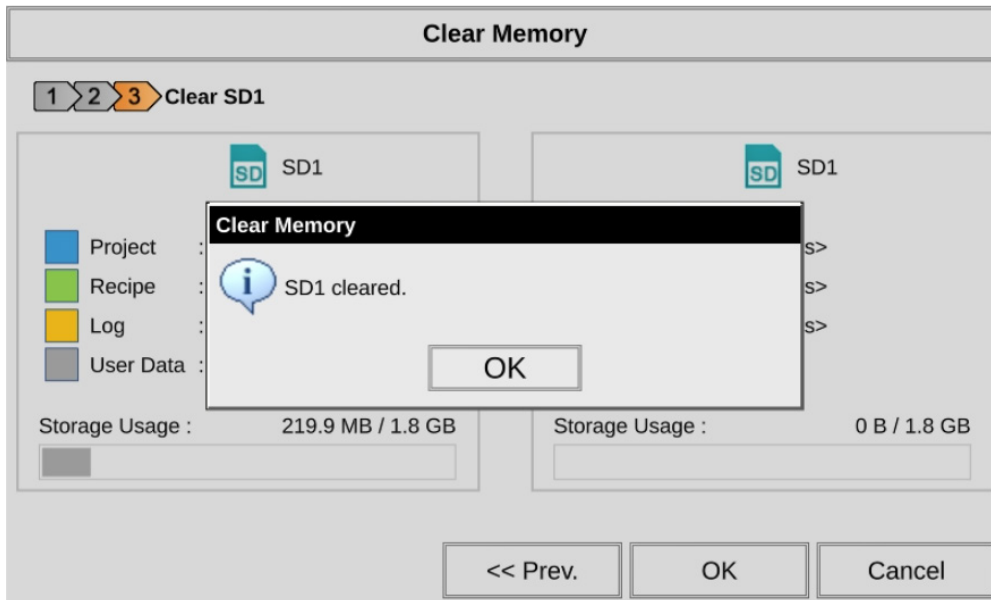

Memory Clear Warning Message

The warning message shown below will be displayed if the clearing process fails.

Invalid Storage is selected %device%.

%device% will show **SD1**, or **USB 1, 2, or 3**.

Press the OK button to return to the Memory screen and try again. If the selected memory still fails to clear, then refer to **Chapter 8: Troubleshooting** and **Appendix C: System Screen Error Codes** for additional help.

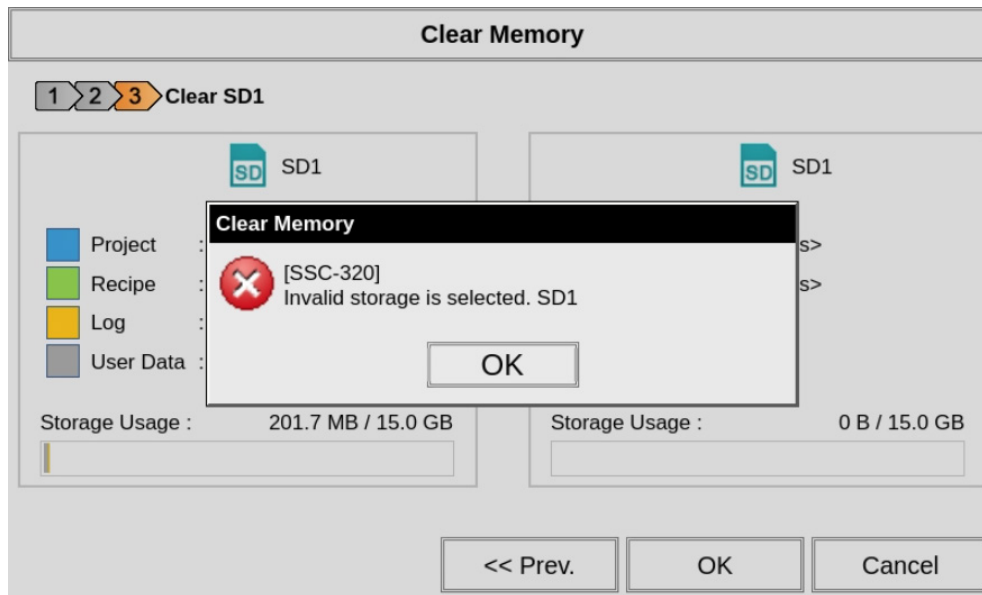

Memory — Reset to Factory Default

To reset the **C-more** panel to factory default settings, press Reset to Factory Default. The following message appears.

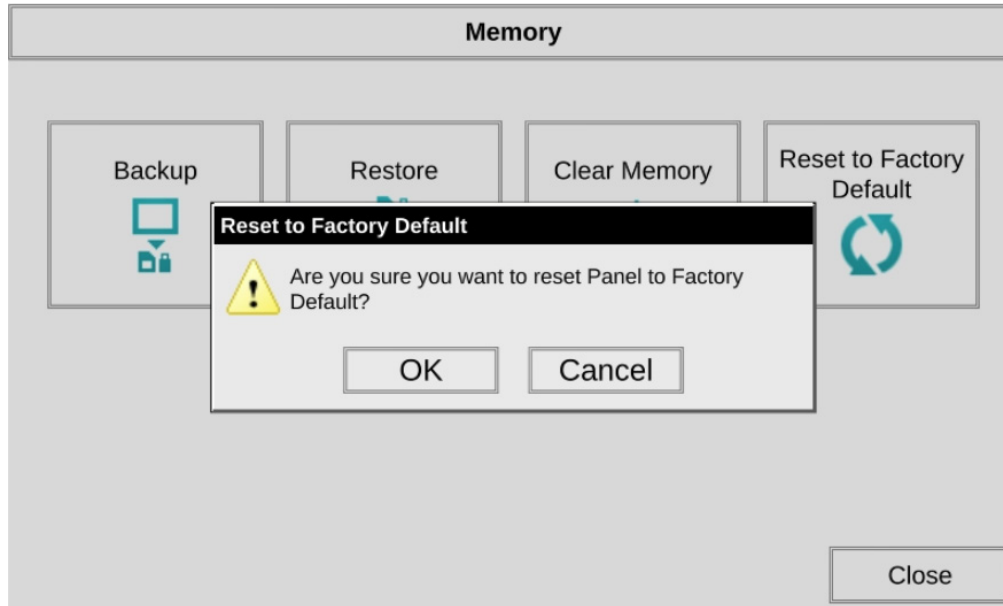

Resetting to factory defaults produces the following actions:

- 1) The touch screen calibration is reset.
- 2) The project file is cleared.
- 3) The log, recipe & WAV files are cleared.
- 4) The IP address is set to DHCP.
- 5) Time Zone is set to UTC-5
- 6) Orientation is set to 0 degrees



WARNING: As a precaution, it is recommended to create a backup file to an SD card or USB storage device using the Memory Backup function before resetting to factory defaults.

**BLANK
PAGE**

PLC COMMUNICATIONS



CHAPTER

6

In this Chapter...

Introduction	6-2
<i>Direct</i>LOGIC PLCs Password Protection	6-2
PLC Protocols	6-3
PLC Communication Cables & Wiring Diagrams	6-5
Cables from AutomationDirect	6-6
AutomationDirect PLCs RS-232C Serial Cables Wiring Diagrams	6-7
EA-2CBL	6-7
EA-2CBL-1	6-7
EA-3CBL	6-7
EA-4CBL-1	6-8
EA-4CBL-2	6-8
AutomationDirect PLCs PLCs RS-422A/RS-485A Cables Wiring Diagrams.....	6-9
DirectLOGIC Universal Isolated Network Adapter, p/n FA-ISOCAN:	6-13
DirectLOGIC Universal Converter, p/n F2-UNICON:	6-14
RS-422A/RS-485A Multi-Drop Wiring Diagram Examples	6-15
Allen-Bradley PLCs RS-232C/RS-485A Serial Cables Wiring Diagrams	6-19
EA-MLOGIX-CBL	6-19
EA-SLC-232-CBL	6-19
EA-PLC5-232-CBL	6-19
GE PLCs RS-422/RS-232C Serial Cables Wiring Diagrams.....	6-22
EA-90-30-CBL.....	6-22
Mitsubishi PLCs RS-422/RS-232C Serial Cables Wiring Diagrams	6-23
EA-MITSU-CBL	6-23
EA-MITSU-CBL-1	6-23
Omron PLCs RS-232C Serial Cables Wiring Diagrams.....	6-25
EA-OMRON-CBL	6-25
Modicon PLCs RS-232C Serial Cables Wiring Diagrams.....	6-25
Siemens PLCs RS-485A Serial Cables Wiring Diagrams	6-27

Introduction

The **C-more** family of HMIs are capable of communicating with a wide variety of Programmable Logic Controllers. **C-more** is capable of communicating over RS232, RS422 and RS485 serial networks as well as Ethernet networks. It communicates with all AutomationDirect PLC's utilizing various protocols. **C-more** also communicates with other brands of PLCs by their different protocols. The table on the next page lists all of the various PLCs and protocols that can be configured. The page after the protocol table lists the various serial communication cables that are available to purchase. The rest of this chapter is devoted to showing the pin-to-pin connections of all the available cables plus wiring diagrams that the users can refer to in order to construct their own cables, along with wiring diagrams of cables that are not available for purchase. To simplify RS422/RS485 wiring schemes, we have included wiring diagrams showing connections for available terminal connectors such as our ZIPLink Communication Adapter Module, p/n ZL-CMA15, used for example with our DL-06 and D2-260 PLCs.

If you have difficulty determining whether the particular PLC and/or protocol you are using will work with the **C-more** series of HMIs, please contact our technical support group at 770- 844-4200

DirectLOGIC PLCs Password Protection



NOTE: Many **DirectLogic** PLCs support multi-level password protection of the ladder program. This allows password protection while not locking the communication port to an operator interface. The multilevel password can be invoked by creating a password with an upper case "A" followed by seven numeric characters (e.g. A1234567). Please refer to the specific PLC user manual for further details.

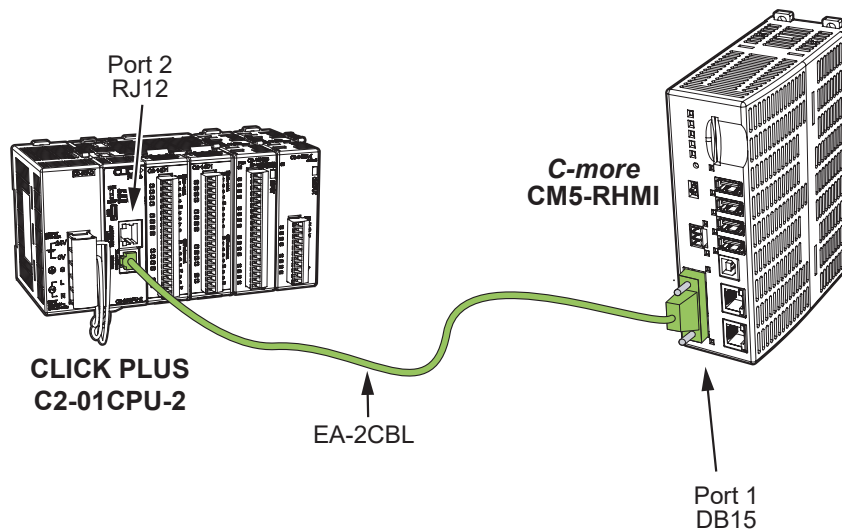

PLC Protocols

PLC Protocol Table			
Model	Protocols		
AutomationDirect	Productivity Series		
	Productivity Serial		
	Productivity Ethernet		
	Do-more (BRX)	All	Do-more Serial
			Do-more Ethernet
	CLICK	All	CLICK Serial
		C0-1x series	CLICK Ethernet
	CLICK PLUS	C2-01CPU-x, C2-03CPU-x, All with C2-DCM	CLICK Serial
		All	CLICK Ethernet
	DL05/DL06	All	K-Sequence
			DirectNET
			Modbus (Koyo addressing)
		H0-ECOM/H0-ECOM100	DirectLOGIC Ethernet
	DL105	All	K-Sequence
	DL205	D2-230	K-Sequence
		D2-240	K-Sequence
			DirectNET
		D2-250/D2-250-1/D2-260/D2-262	K-Sequence
			DirectNET
			Modbus (Koyo addressing)
		D2-240/D2-250-1/D2-260 Using DCM	DirectNET
		Modbus (Koyo addressing)	
	H2-ECOM/H2-ECOM100	DirectLOGIC Ethernet	
	DL305	D3-330/330P (Requires the use of a Data Communications Unit)	DirectNET
		D3-340	DirectNET
		D3-350	K-Sequence
			DirectNET
			Modbus (Koyo addressing)
	D3-350 DCM	DirectNET	
		Modbus (Koyo addressing)	
DL405	D4-430	K-Sequence	
		DirectNET	
	D4-440	K-Sequence	
		DirectNET	
	D4-450/D4-454	K-Sequence	
		DirectNET	
	Modbus (Koyo addressing)		
All with DCM	DirectNET		
	Modbus (Koyo addressing)		
	H4-ECOM/H4-ECOM100	DirectLOGIC Ethernet	
H2-WinPLC (Think & Do) Live V5.2 or later and Studio any version		Think & Do Modbus RTU (serial port)	
H2-WinPLC (Think & Do) Live V5.5.1 or later and Studio V7.2.1 or later		Think & Do Modbus TCP/IP (Ethernet port)	
GS Drives		GS Drives Serial	
		GS Drives TCP/IP (GS-EDRV)	
SOLO Temperature Controllers (models with serial communications)		SOLO Temperature Controller	

PLC Protocols (cont'd)

PLC Protocol Table (cont'd)		
Model		Protocols
Allen-Bradley	MicroLogix 1000, 1100, 1200, 1400 and 1500	DF1 Half Duplex; DF1 Full Duplex
	SLC 5-03/04/05	
	ControlLogix™, CompactLogix™, FlexLogix™	
	PLC-5	DF1 Full Duplex
	ControlLogix, CompactLogix, FlexLogix - Tag Based	DF1 Half Duplex; DF1 Full Duplex
	ControlLogix, CompactLogix, FlexLogix - Generic I/O Messaging	EtherNet/IP Server
	ControlLogix, CompactLogix, FlexLogix - Tag Based	EtherNet/IP Client
	MicroLogix 1100, 1400 and SLC 5/05, via native Ethernet port	
	MicroLogix 1000, 1100, 1200, 1400, 1500, SLC 5-03/04/05, all via ENI adapter	
	Micro 800 Series	Modbus RTU
		Modbus TCP
Micro 800 Series - Tag Based	DF1 Full Duplex	
	EtherNet/IP Client	
Modbus RTU	Modbus RTU devices	Modbus RTU
Modbus TCP/IP	Modbus TCP/IP devices	Modbus TCP/IP
GE	90/30, 90/70, Micro 90, VersaMax Micro	SNPX
	90/30, Rx3i	S RTP Ethernet
Mitsubishi	FX Series	FX Direct
	Q02, Q02H, Q06H, Q12H, Q25H	Q CPU
	Q, QnA Serial	QnA Serial
	Q, QnA Ethernet	QnA Ethernet
Modicon	984 CPU, Quantum 113 CPU, AEG Modicon Micro Series 110 CPU: 311-xx, 411-xx, 512-xx, 612-xx	Modbus RTU
	Other devices using Modicon Modbus addressing	Modbus RTU Modbus TCP/IP
Omron	C200 Adapter, C500	Host Link
	CJ1/CS1 Serial	FINS
	CJ1/CS1 Ethernet	
Siemens	S7-200 CPU, RS-485 Serial	PPI
	S7-200 CPU, S7-300 CPU, S7-400, S7-1200, S7-1500 CPU Ethernet	Ethernet ISO over TCP

PLC Communication Cables & Wiring Diagrams

Cable Description	Cable Part No.
Cables used with 15-pin RS-232/422/485 serial Port1	
AutomationDirect Productivity Series, Do-more, CLICK, Direct LOGIC PLC RJ-12 port, DL05, DL06, DL105, DL205, D3-350, D4-450 & H2-WinPLC (RS-232C) 3m (9.8 ft) cable length	EA-2CBL
Direct LOGIC (VGA Style) 15-pin port, DL06, D2-250 (250-1), D2-260 (RS-232C) 3m (9.8 ft) cable length	EA-2CBL-1
Direct LOGIC PLC RJ-11 port, D3-340 (RS-232C) 3m (9.8 ft) cable length	EA-3CBL
Direct LOGIC DL405 PLC 15-pin D-sub port, DL405 (RS-232C) 3m (9.8 ft) cable length	EA-4CBL-1
Direct LOGIC PLC 25-pin D-sub port, DL405, D3-350, DL305 DCU and all DCM's (RS-232C) 3m (9.8 ft) cable length	EA-4CBL-2
Allen-Bradley MicroLogix 1000, 1100, 1200, 1400 & 1500 (RS-232C) 3m (9.8 ft) cable length	EA-MLOGIX-CBL
Allen-Bradley SLC 5-03/04/05, ControlLogix, CompactLogix, FlexLogix DF1 port (RS-232C)	EA-SLC-232-CBL
Allen-Bradley PLC-5 DF1 port (RS-232C) 3m (9.8 ft) cable length	EA-PLC5-232-CBL
GE 90/30, 90/70, Micro 90, Versamax Micro (Port2) 15-pin D-sub port (RS-422A) 3m (9.8 ft) cable length	EA-90-30-CBL
MITSUBISHI FX Series 25-pin port (RS-422A) 3m (9.8 ft) cable length	EA-MITSU-CBL
MITSUBISHI FX Series 8-pin mini-DIN (RS-422A) 3m (9.8 ft) cable length	EA-MITSU-CBL-1
OMRON Host Link (C200 Adapter, C500) (RS-232C) 3m (9.8 ft) cable length	EA-OMRON-CBL

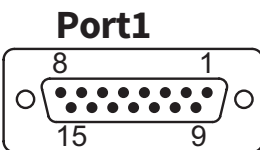

D-Sub 15-pin female
on front of the CM5-RHMI
RS-232C, RS-422, RS-485

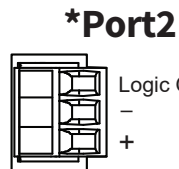

Logic Ground
-
+
RS-485 Serial Communications



NOTE: All cables for connections at Port 2 are user constructed. Refer to the specifications of the connected device port to construct the cable properly. The connector for Port 2, HMI-3TB, is included with your C-more panel.

Cables from AutomationDirect

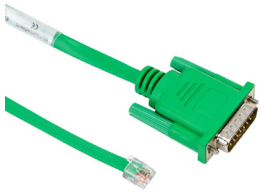

Part No. EA-2CBL



Part No. EA-2CBL-1

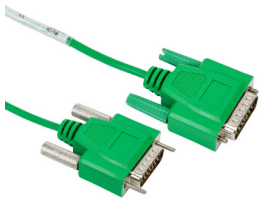

Part No. EA-4CBL-1

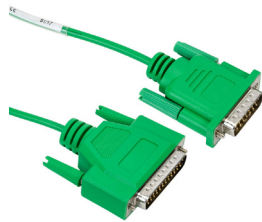

Part No. EA-4CBL-2



Part No. EA-3CBL



Part No. EA-MLOGIX-CBL

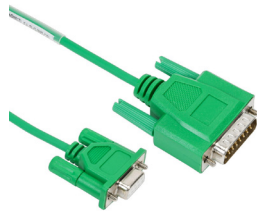

Part No. EA-SLC-232-CBL



Part No. EA-PLC5-232-CBL

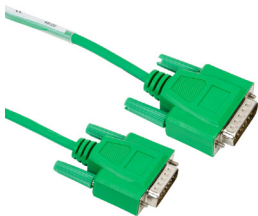

Part No. EA-90-30-CBL



Part No. EA-OMRON-CBL



Part No. EA-MITSU-CBL

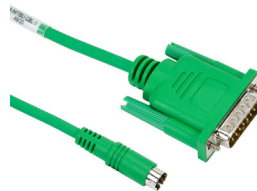

Part No. EA-MITSU-CBL-1

AutomationDirect PLCs RS-232C Serial Cables Wiring Diagrams

The following series of wiring diagrams show the connectors and wiring details for the communication cables that are used between the **C-more** touch panels and various PLC controllers. Part numbers are included with the pre-made cables that can be purchased from AutomationDirect. The information presented will allow the user to construct their own cables if so desired.

EA-2CBL

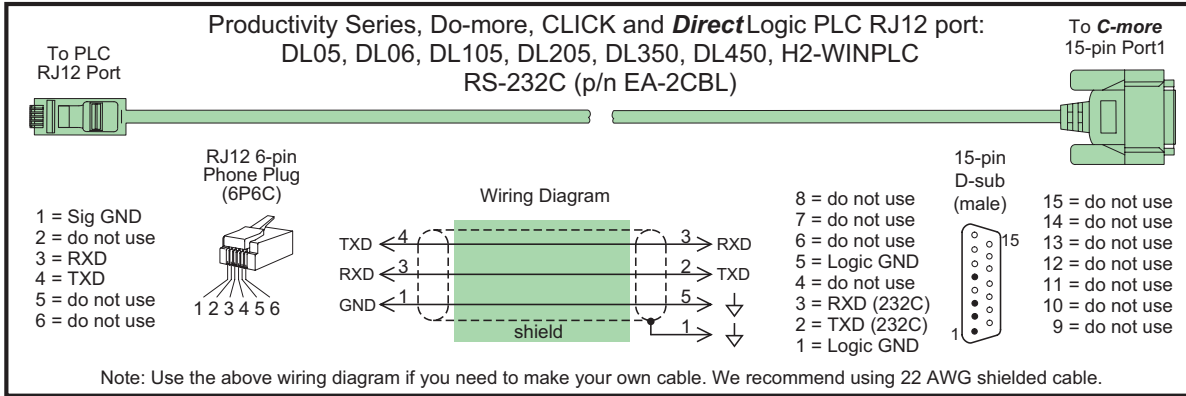

EA-2CBL-1

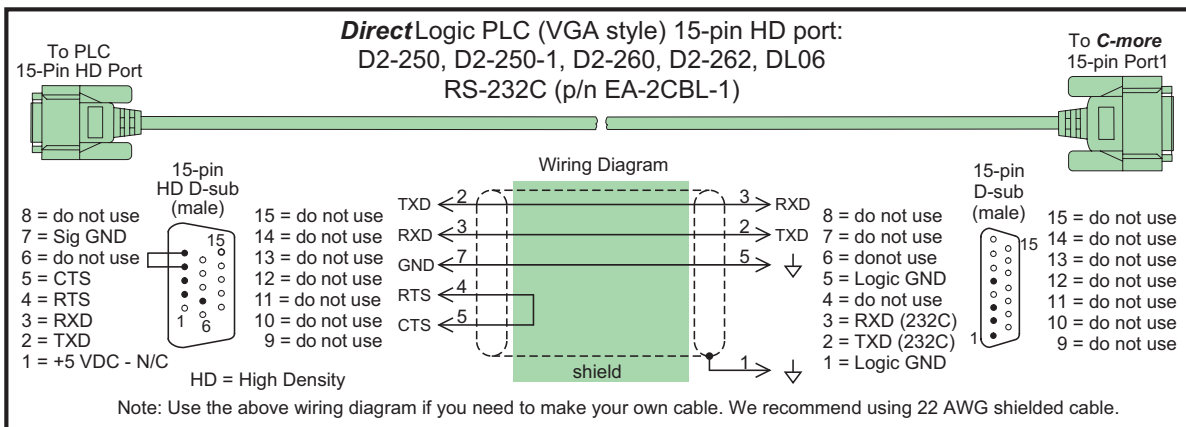

EA-3CBL

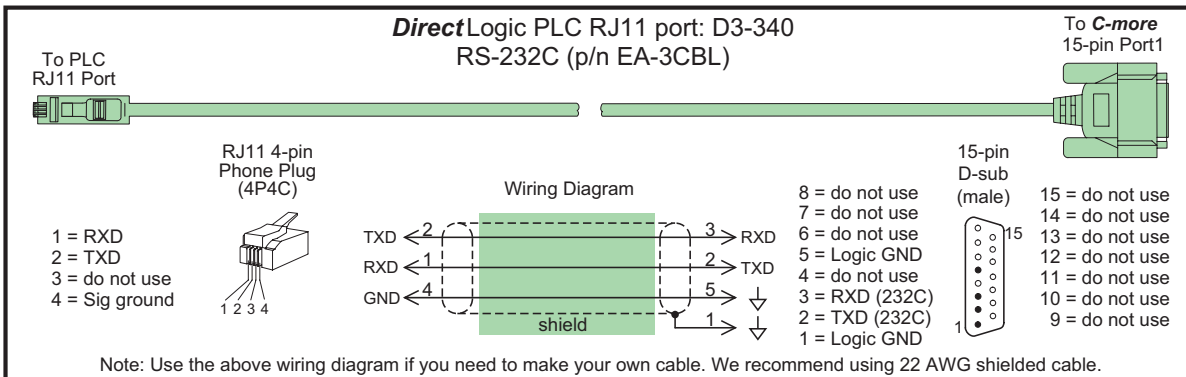

EA-4CBL-1

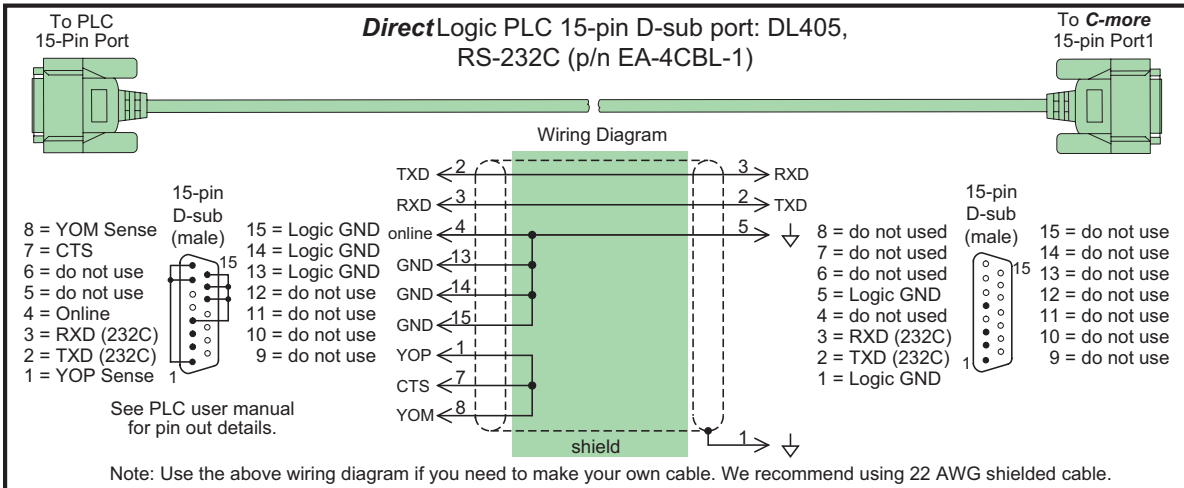

EA-4CBL-2

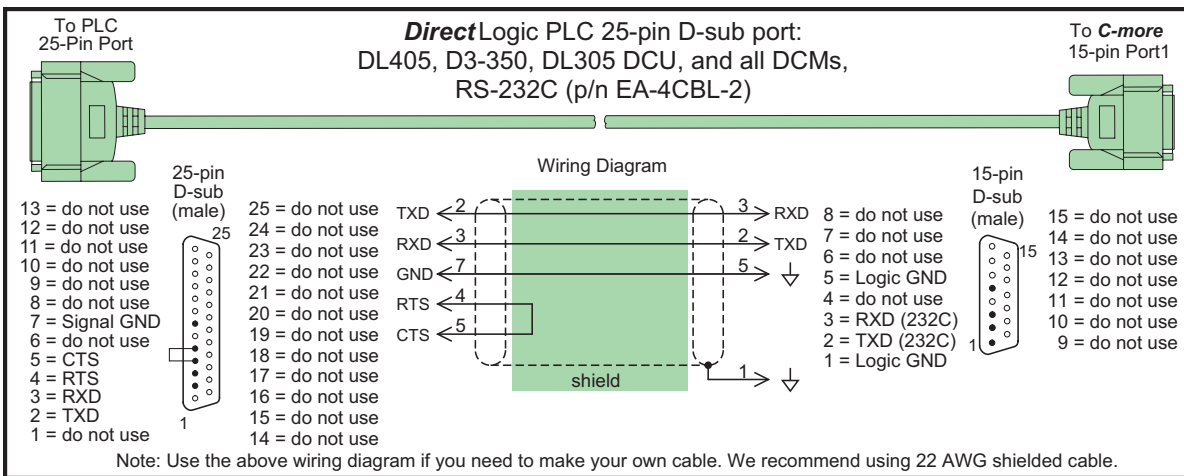

AutomationDirect PLCs RS-422A/RS-485A Cables Wiring Diagrams

When using the RS-422A/RS-485A capabilities of the **C-more** 15-pin PLC communications Port1, the termination resistor is placed between the RXD- and RXD+ terminals on the PLC side of the connection between the touch panel and PLC. The Termination Resistor value is based on the characteristic impedance of the cable being used. To enable the built-in 120 Ohm Termination Resistor, jumper pin 13 to pin 9 (RXD+) on the **C-more** 15-pin PLC communications Port1.

User Constructed

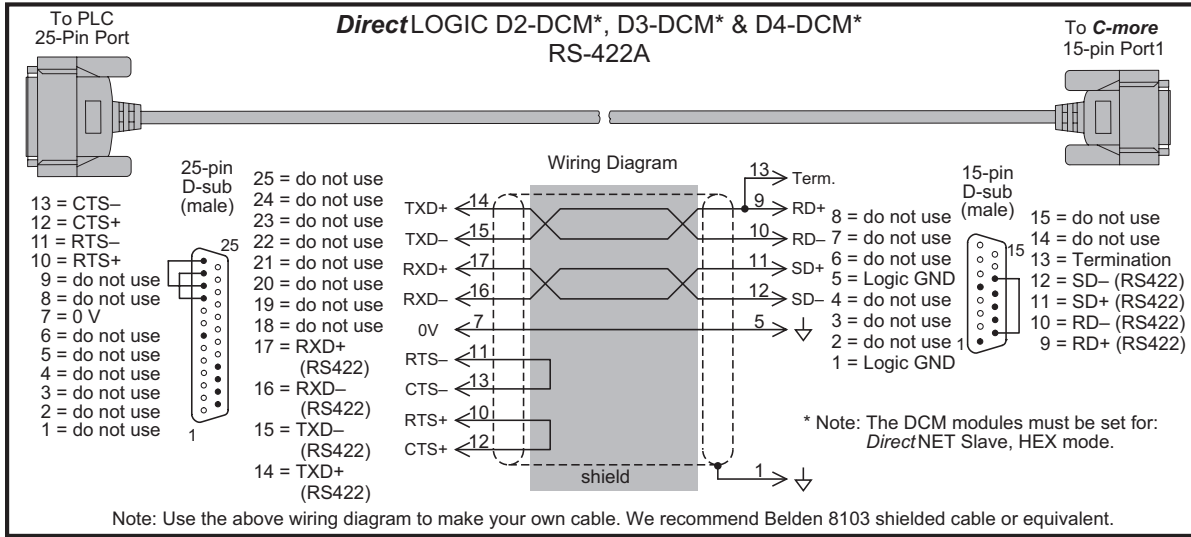

User Constructed

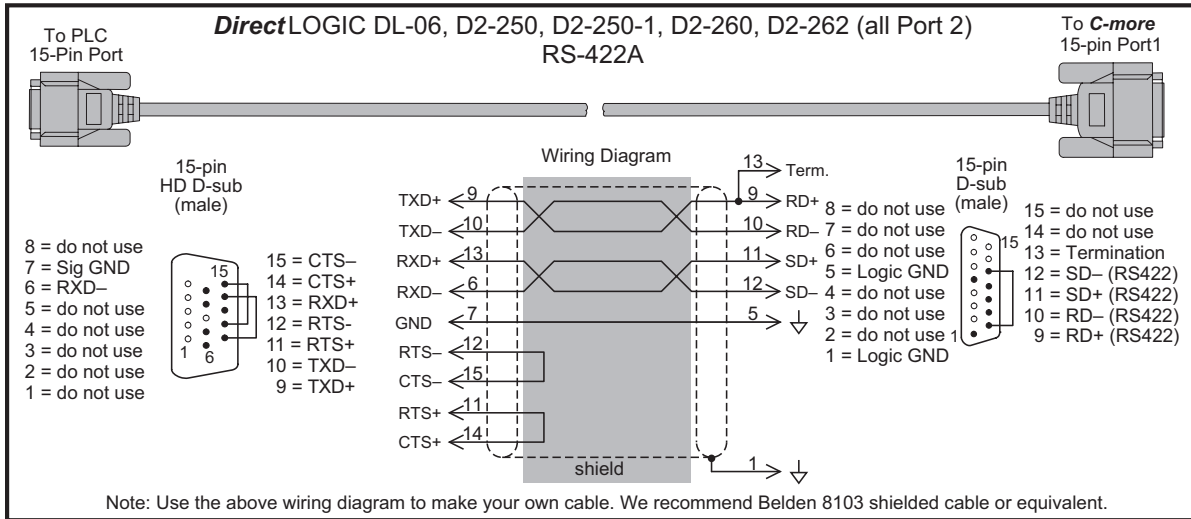

NOTE: The RS-422 wiring diagrams shown above are not for multi-drop networks involving connecting more than one PLC to a panel. Refer to the multi-drop wiring diagram examples later in this chapter if more than one PLC will be connected to a panel.

User Constructed

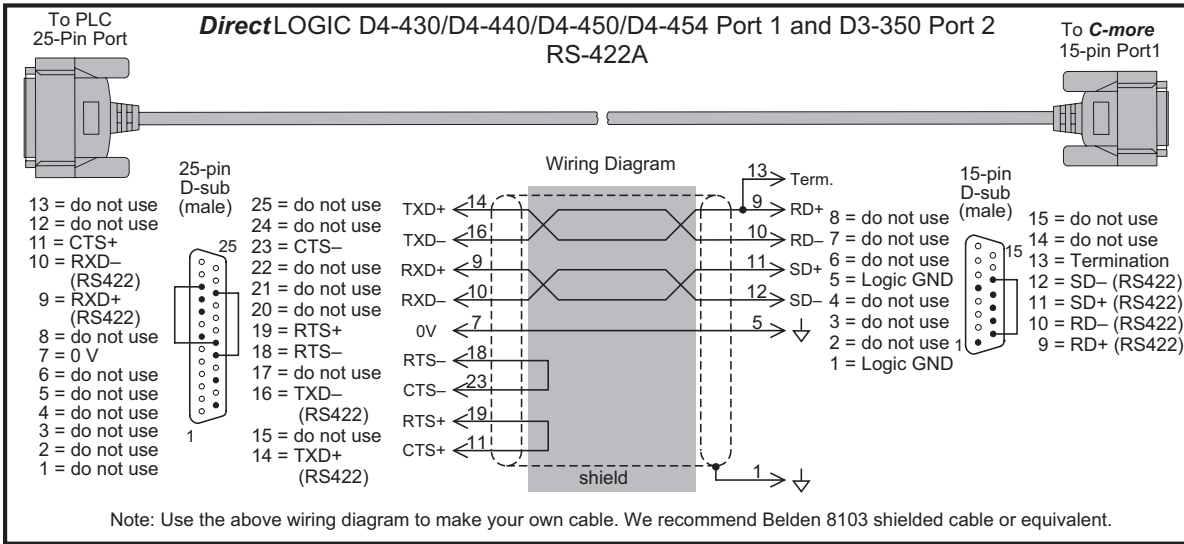

User Constructed

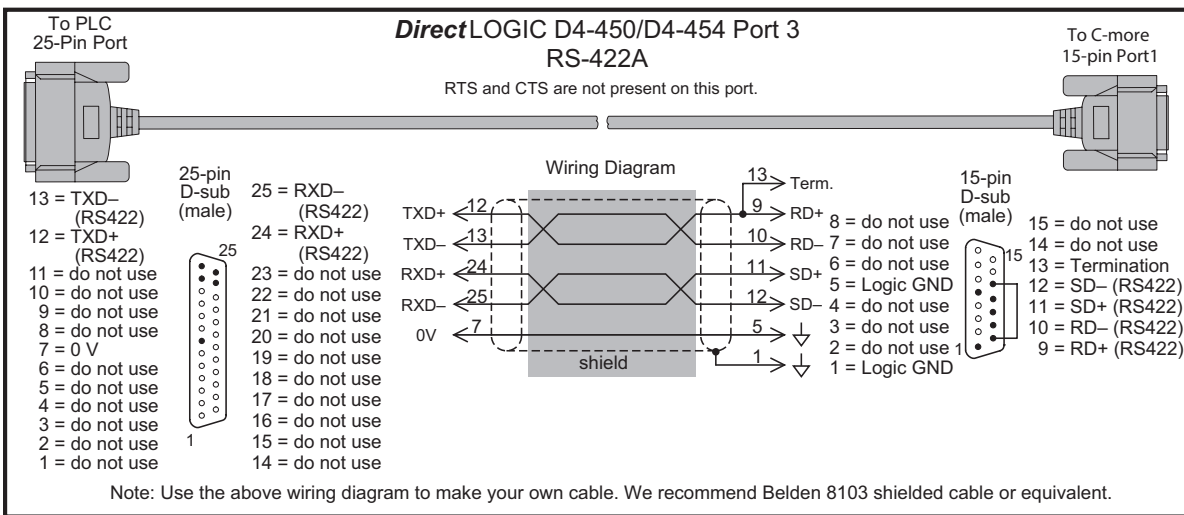

NOTE: The RS-422 wiring diagrams shown above are not for multi-drop networks involving connecting more than one PLC to a panel. Refer to the multi-drop wiring diagram examples later in this chapter if more than one PLC will be connected to a panel.

User Constructed

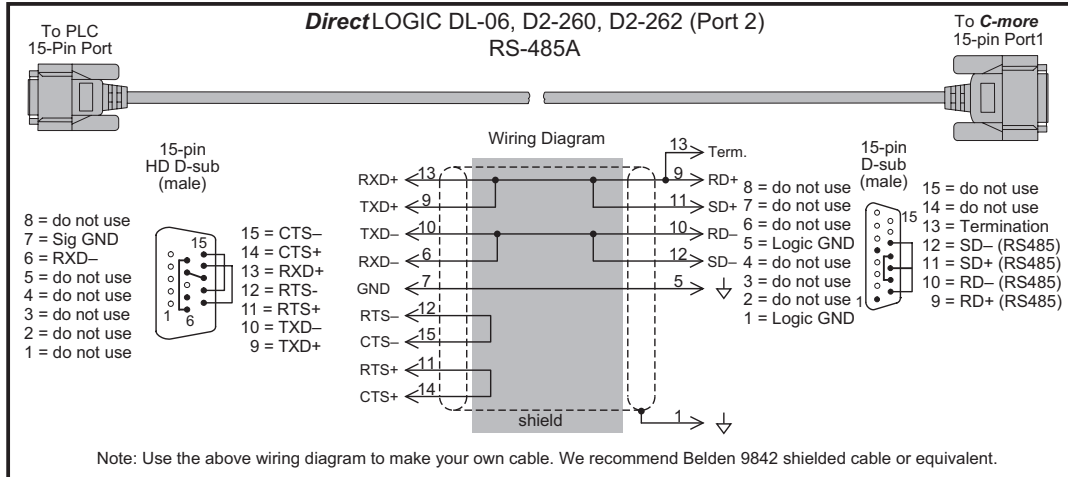

User Constructed

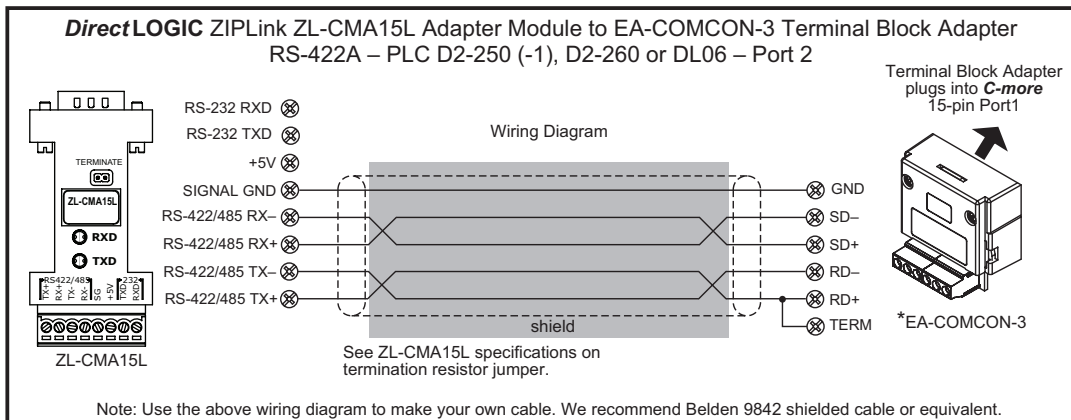

User Constructed

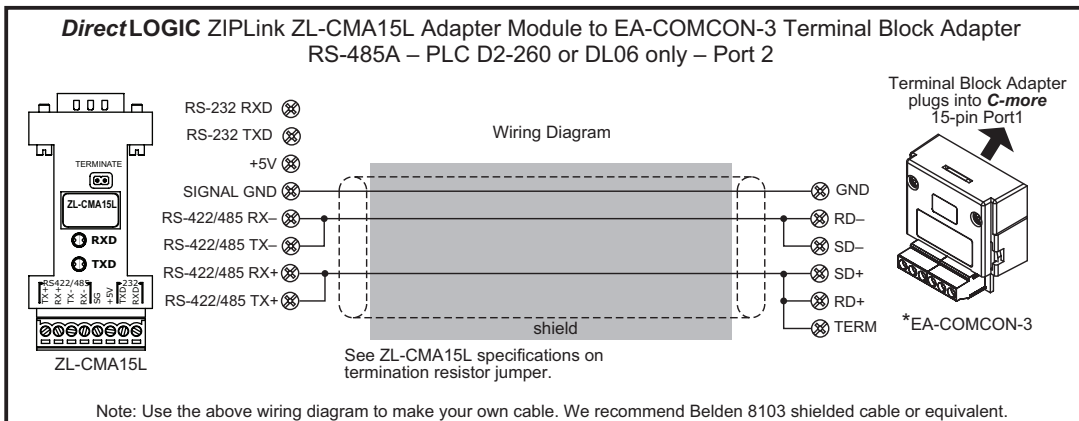

NOTE: EA-COMCON-3 will install only on CM5-T4W. For all other models use EA-COMCON-3A

NOTE: The RS-422 wiring diagrams shown above are not for multi-drop networks involving connecting more than one PLC to a panel. Refer to the multi-drop wiring diagram examples later in this chapter if more than one PLC will be connected to a panel.

User Constructed

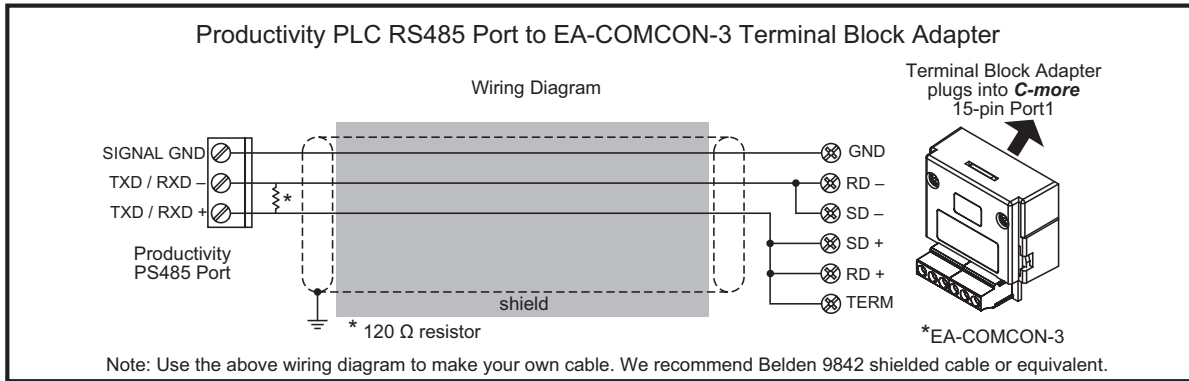

NOTE: EA-COMCON-3 will install only on CM5-T4W. For all other models use EA-COMCON-3A

User Constructed

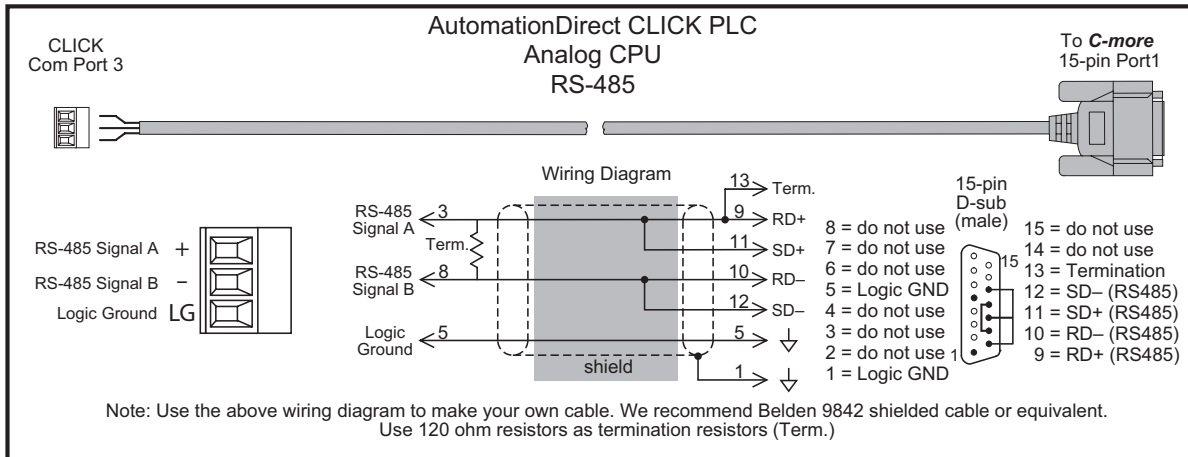

User Constructed

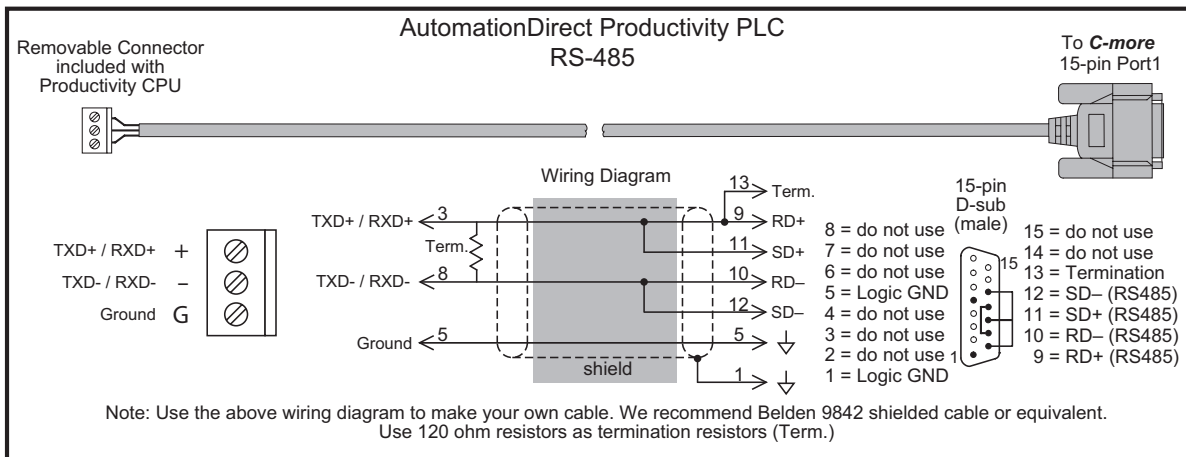

NOTE: The RS-422 wiring diagrams shown above are not for multi-drop networks involving connecting more than one PLC to a panel. Refer to the multi-drop wiring diagram examples later in this chapter if more than one PLC will be connected to a panel.

DirectLOGIC Universal Isolated Network Adapter, p/n FA-ISOCON:

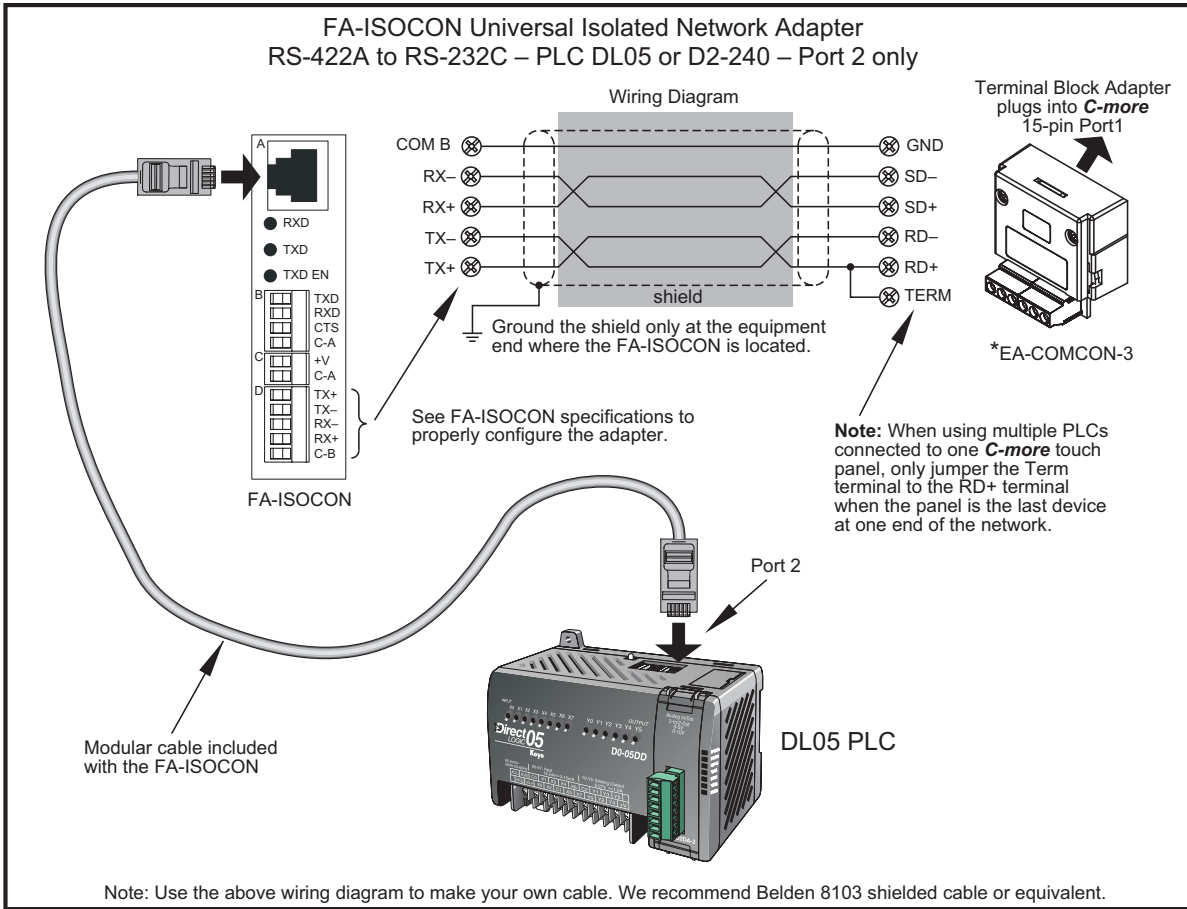

NOTE: EA-COMCON-3 will install only on CM5-T4W. For all other models use EA-COMCON-3A

DirectLOGIC Universal Converter, p/n F2-UNICON:

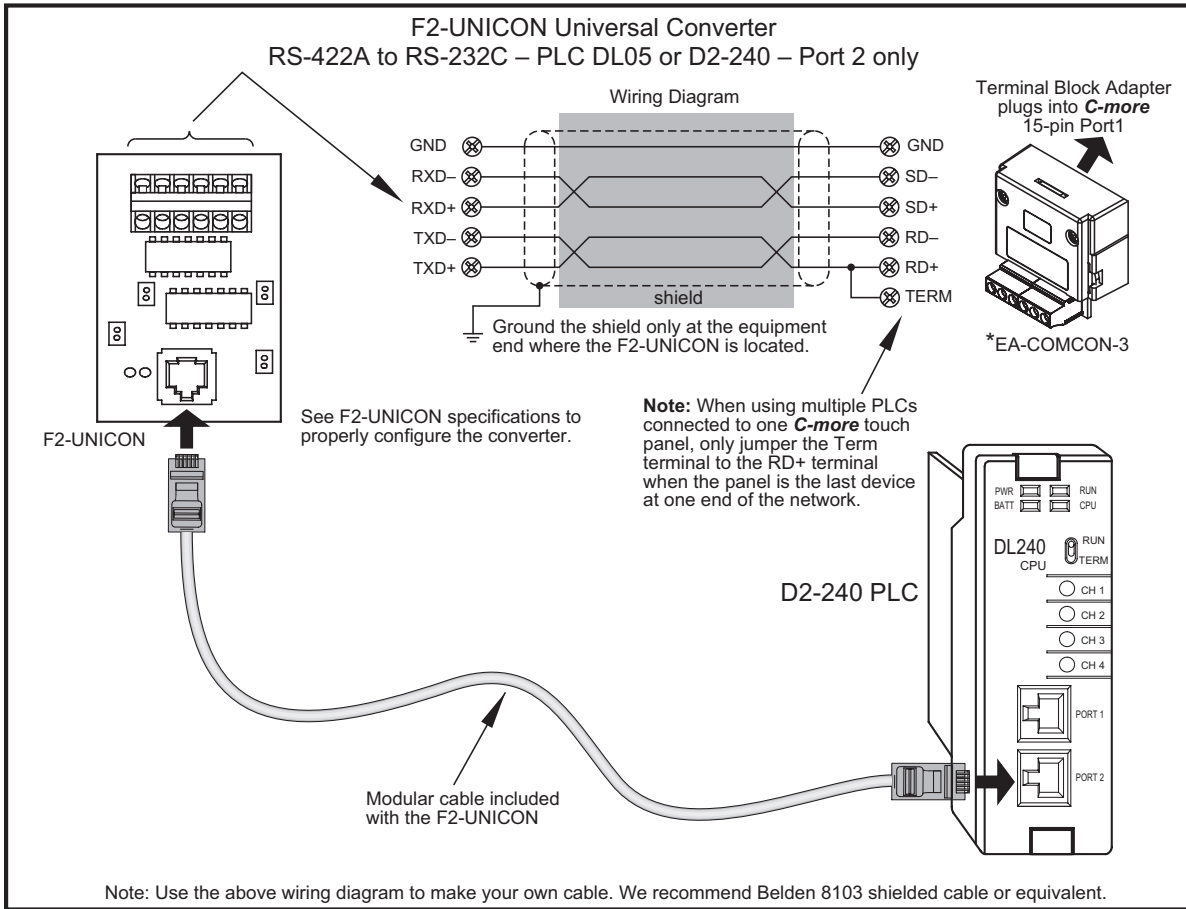

RS-422A/RS-485A Multi-Drop Wiring Diagram Examples

DL06 and DL205 used for illustration purposes

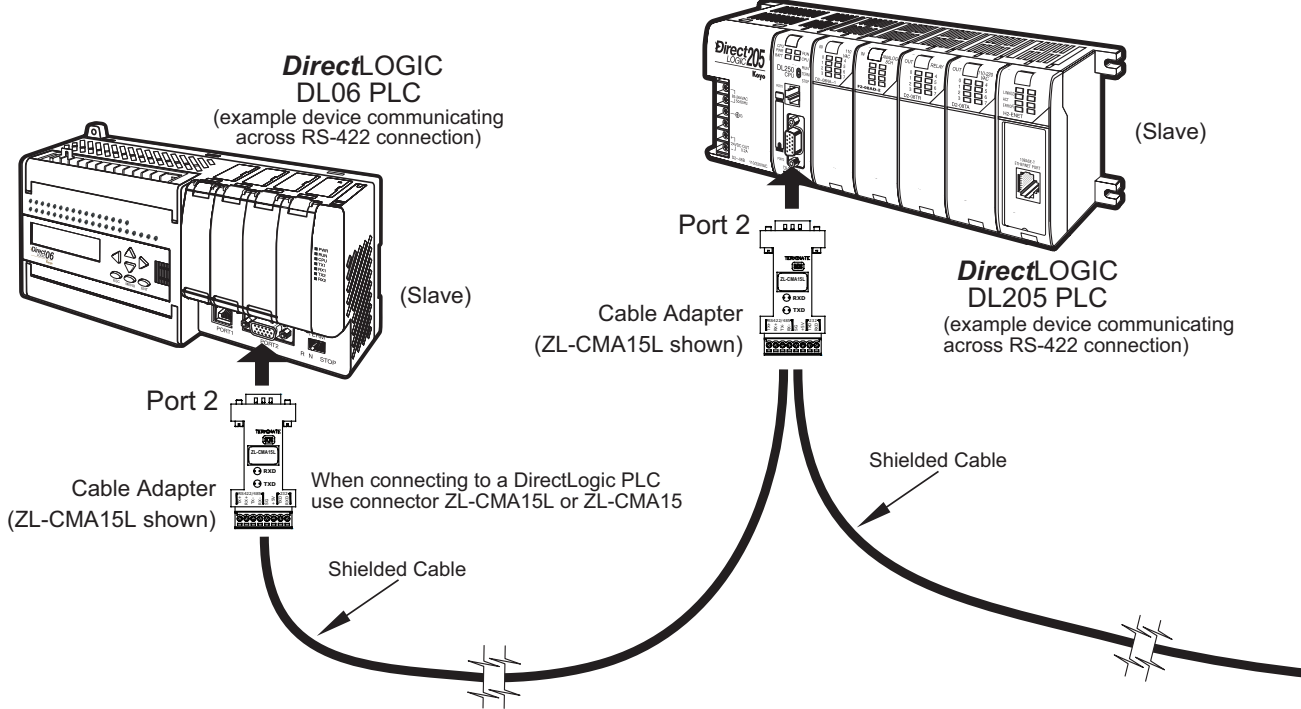

- Notes: 1. We recommend Belden 8103 shielded cable or equivalent.
- 2. Wiring Diagram for this example, ZL-CMA15(L)

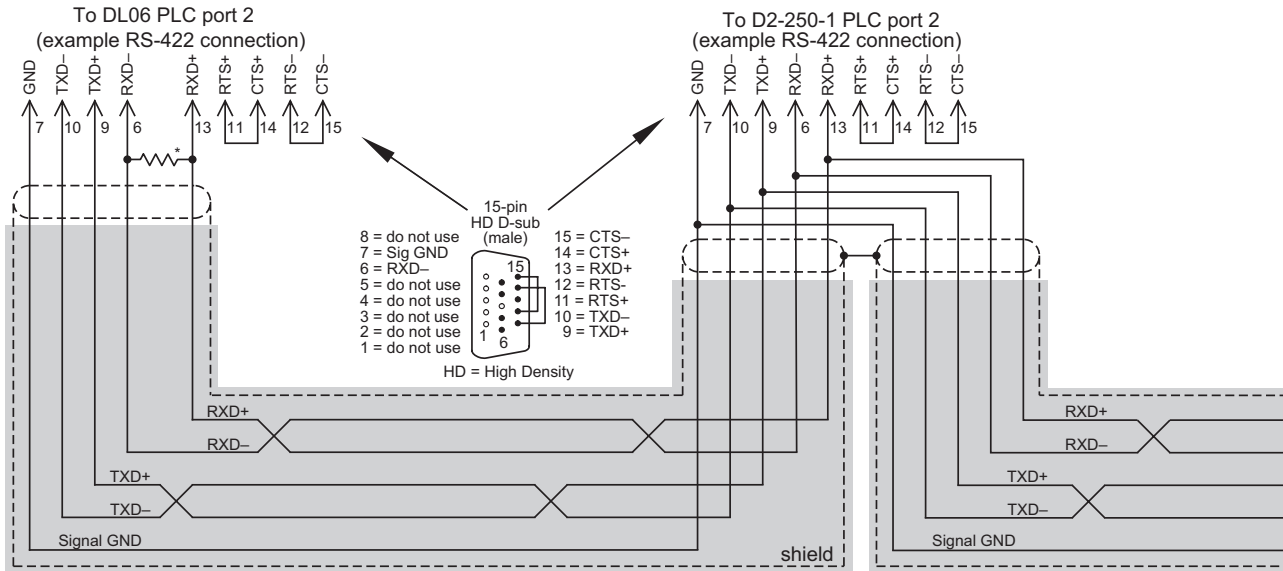

* Termination resistors required at both ends of the network receive data signals to match the impedance of the cable (between 100 and 500 ohms).

Typical RS-422 Multi-Drop Wiring Diagram using DirectLogic pin numbers to illustrate

RS-422A/RS-485A Multi-Drop Wiring Diagram Examples (cont'd)

DL06 and DL205 used for illustration purposes

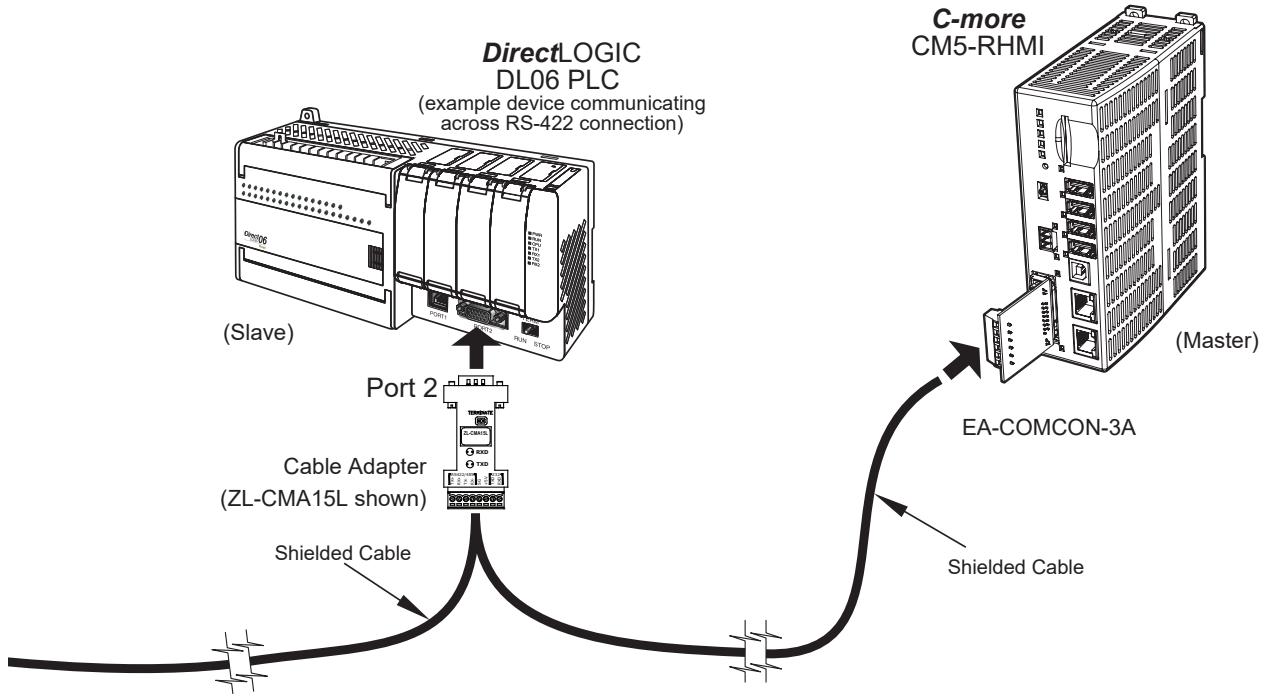

- Notes: 1. We recommend Belden 8103 shielded cable or equivalent.
- 2. Wiring Diagram for this example, ZL-CMA15(L)

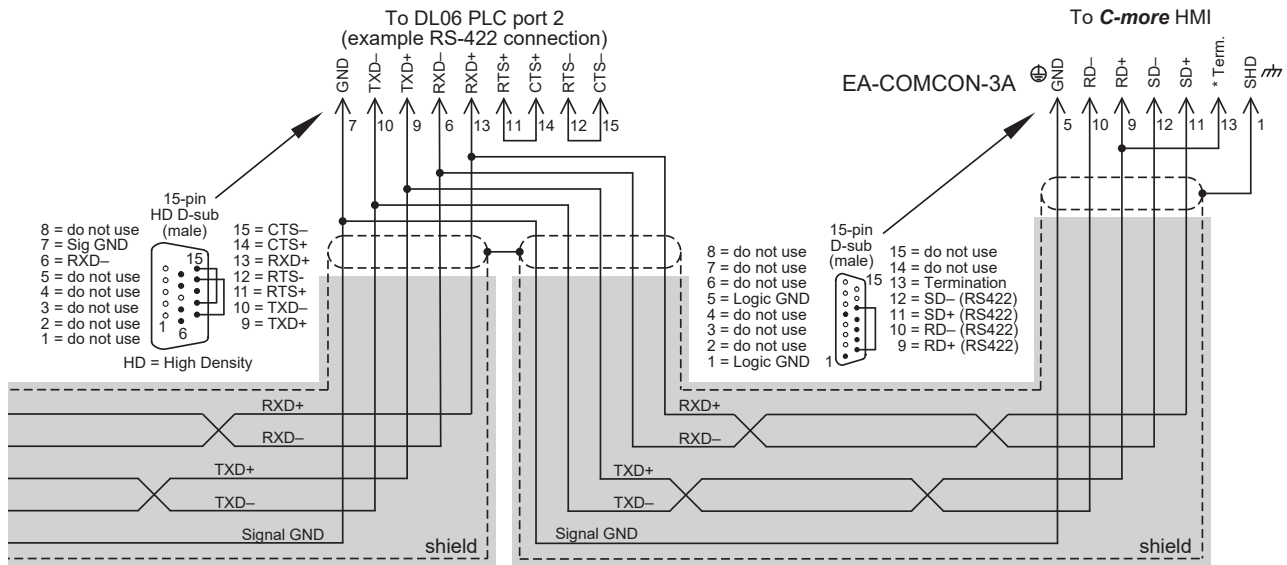

* Termination resistors required at both ends of the network receive data signals to match the impedance of the cable (between 100 and 500 ohms). Jumper pin 13 to 9 on the C-more HMI 15-pin connector to place the 120q internal resistor into the network. If the cable impedance is different, then use an external resistor matched to the cable impedance.

Typical RS-422 Multi-Drop Wiring Diagram (cont-d)
using DirectLogic pin numbers to illustrate

RS-422A/RS-485 Multi-Drop Wiring Diagram Examples (cont'd)

DL06 and DL205 used for illustration purposes

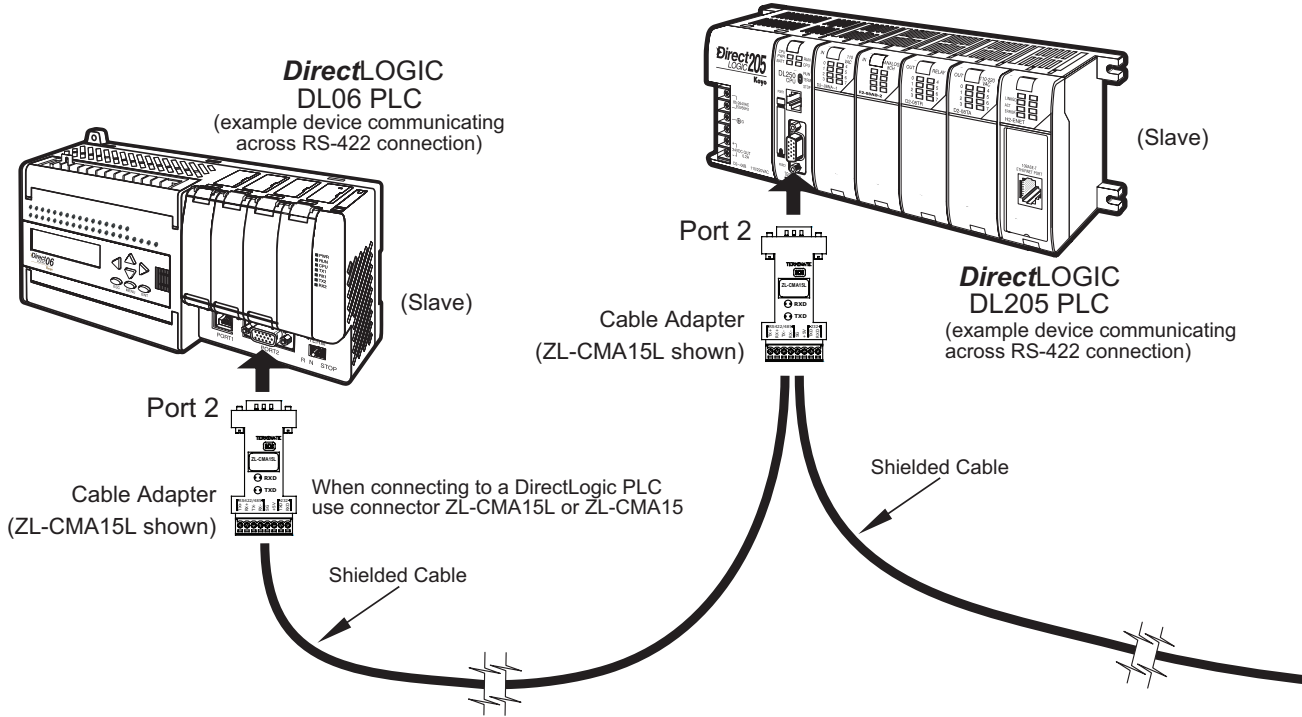

- Notes: 1. We recommend Belden 9842 shielded cable or equivalent.
- 2. Wiring Diagram for this example, ZL-CMA15(L)

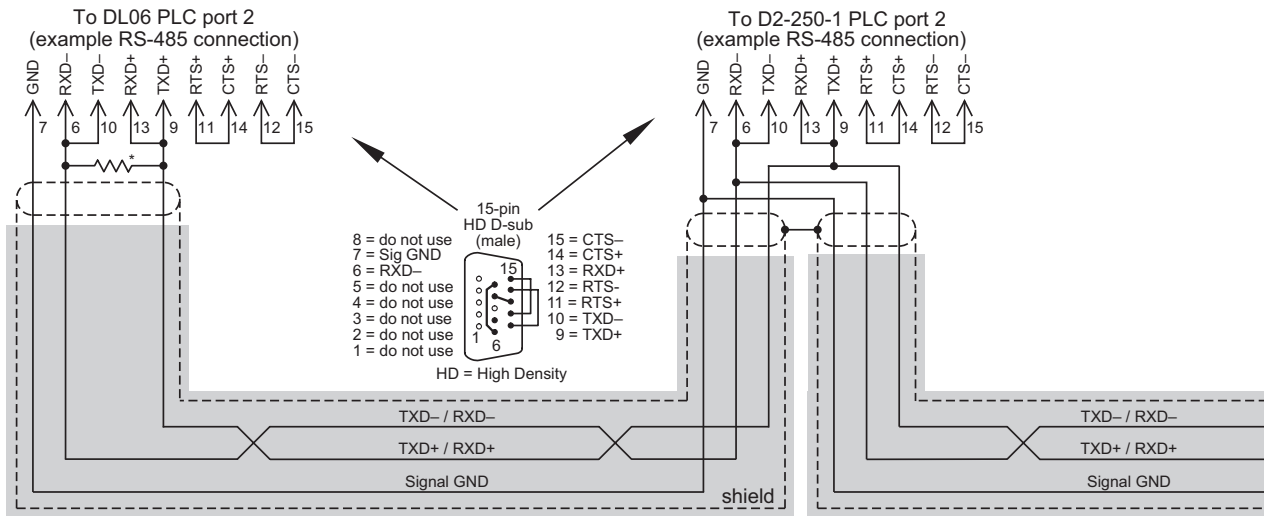

* Termination resistors required at both ends of the network to match the impedance of the cable (between 100 and 500 ohms).

Typical RS-485 Multi-Drop Wiring Diagram using DirectLogic pin numbers to illustrate

RS-422A/RS-485A Multi-Drop Wiring Diagram Examples (cont'd)

DL06 and DL205 used for illustration purposes

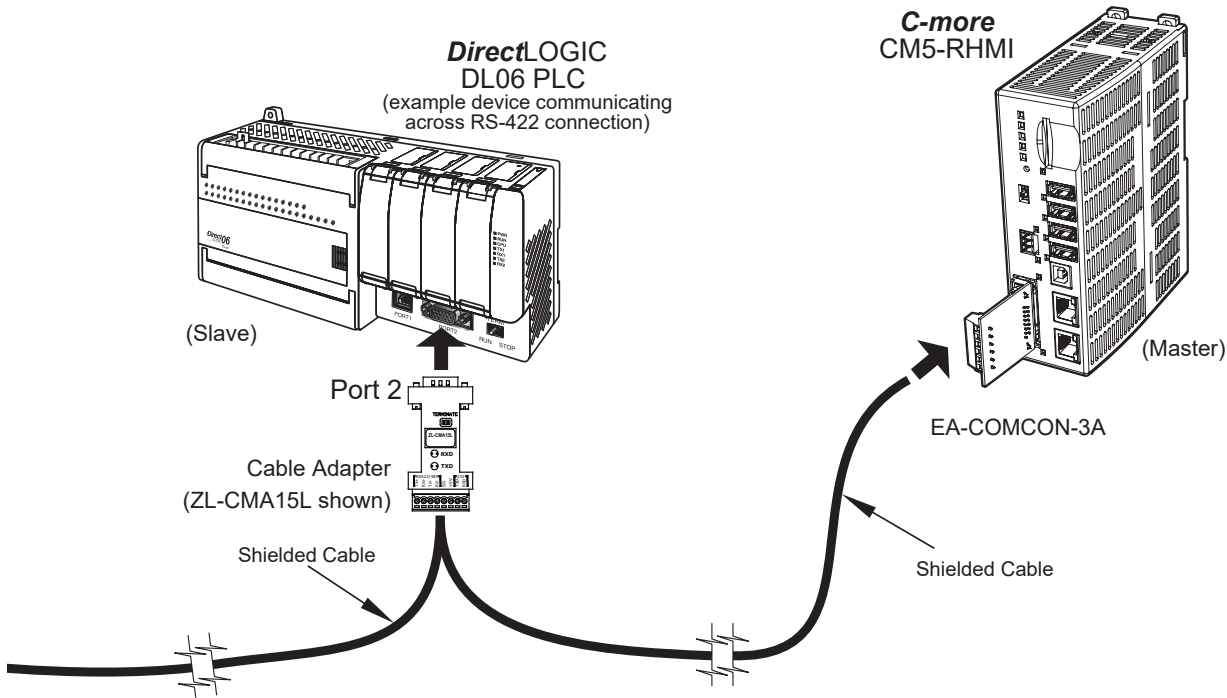

- Notes: 1. We recommend Belden 9842 shielded cable or equivalent.
- 2. Wiring Diagram for this example, ZL-CMA15(L)

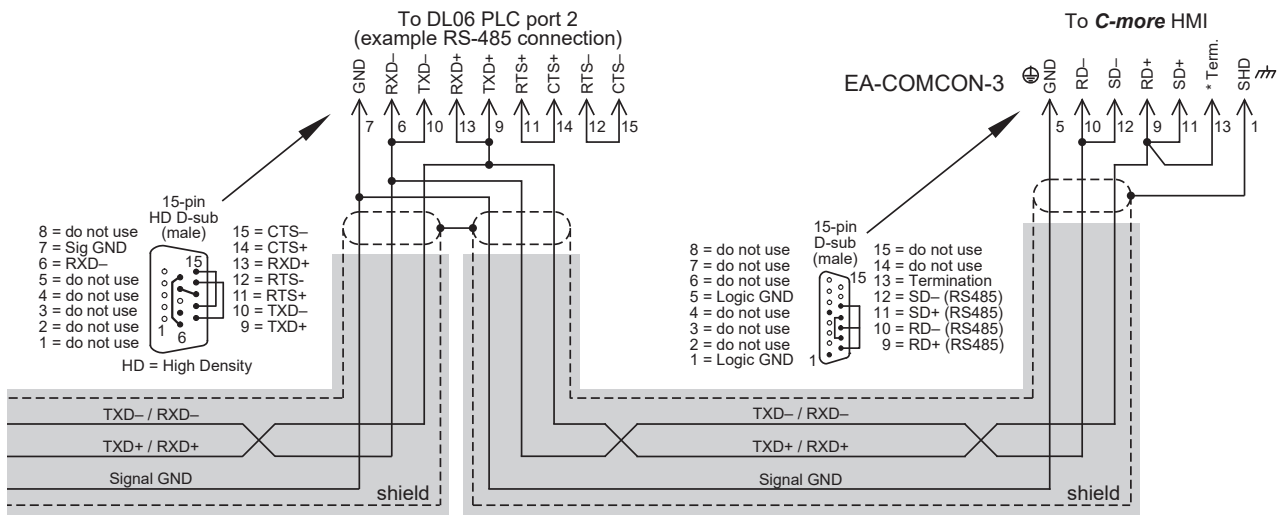

Typical RS-485 Multi-Drop Wiring Diagram (cont-d)

using DirectLogic pin numbers to illustrate

* Termination resistors required at both ends of the network receive data signals to match the impedance of the cable (between 100 and 500 ohms). Jumper pin 13 to 9 on the C-more HMI 15-pin connector to place the 120Ω internal resistor into the network. If the cable impedance is different, then use an external resistor matched to the cable impedance.

Allen-Bradley PLCs RS-232C/RS-485A Serial Cables Wiring Diagrams

The following series of wiring diagrams show the connectors and wiring details for the communication cables that are used between the **C-more** touch panels and Allen-Bradley PLC controllers. Part numbers are included with the pre-made cables that can be purchased from AutomationDirect. The information presented will allow the user to construct their own cables if so desired.

EA-MLOGIX-CBL

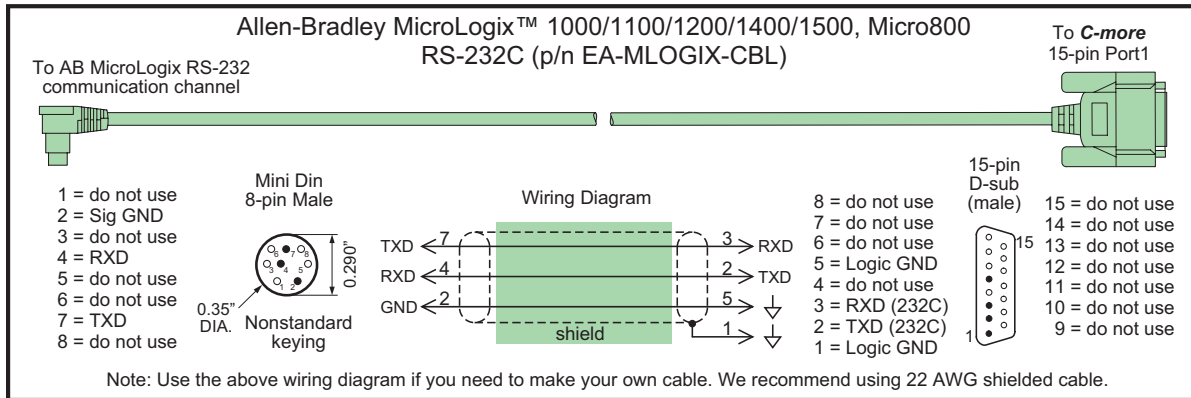

EA-SLC-232-CBL

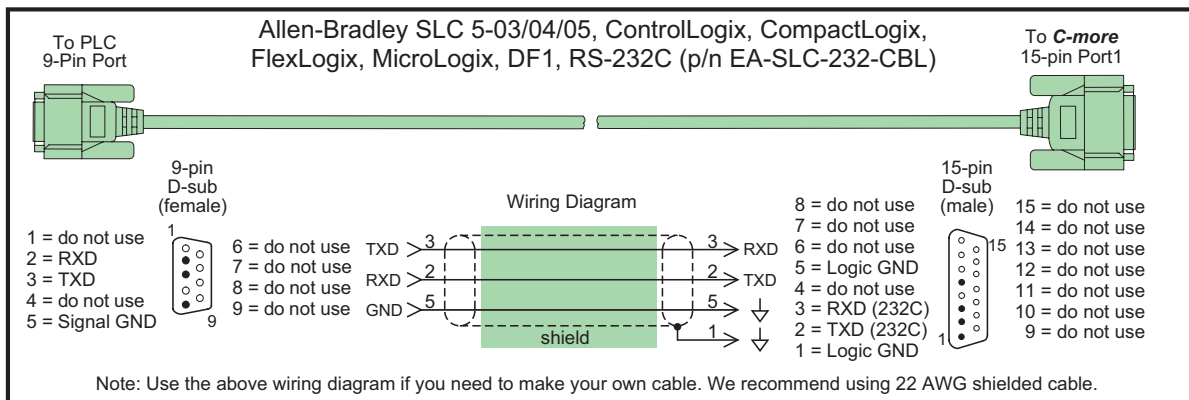

EA-PLC5-232-CBL

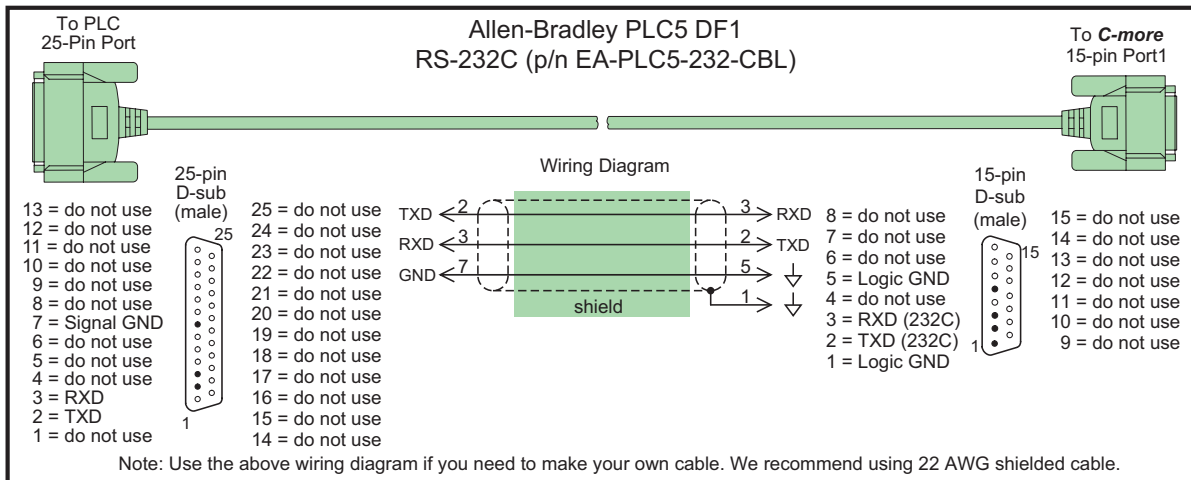

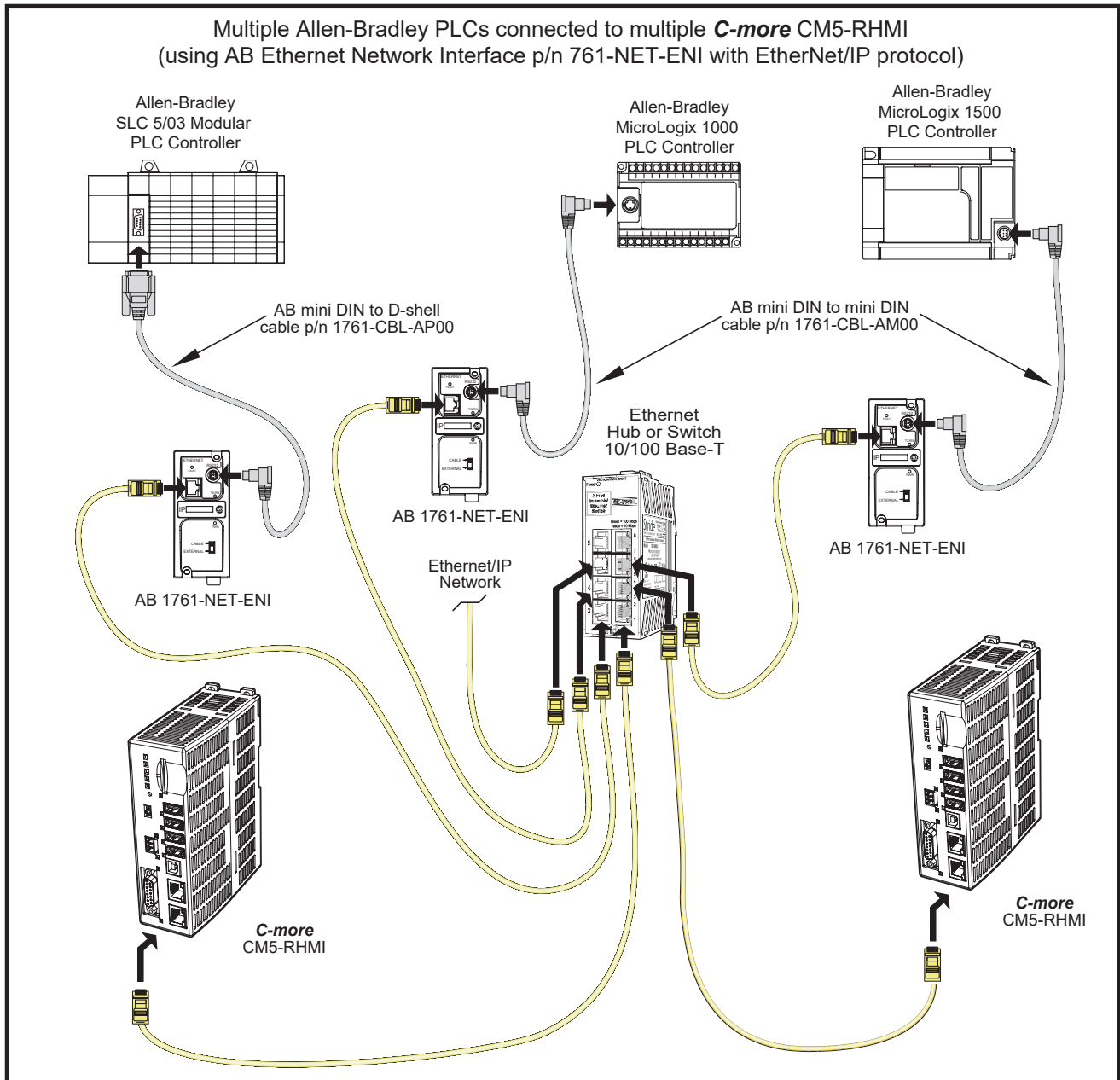

User Constructed

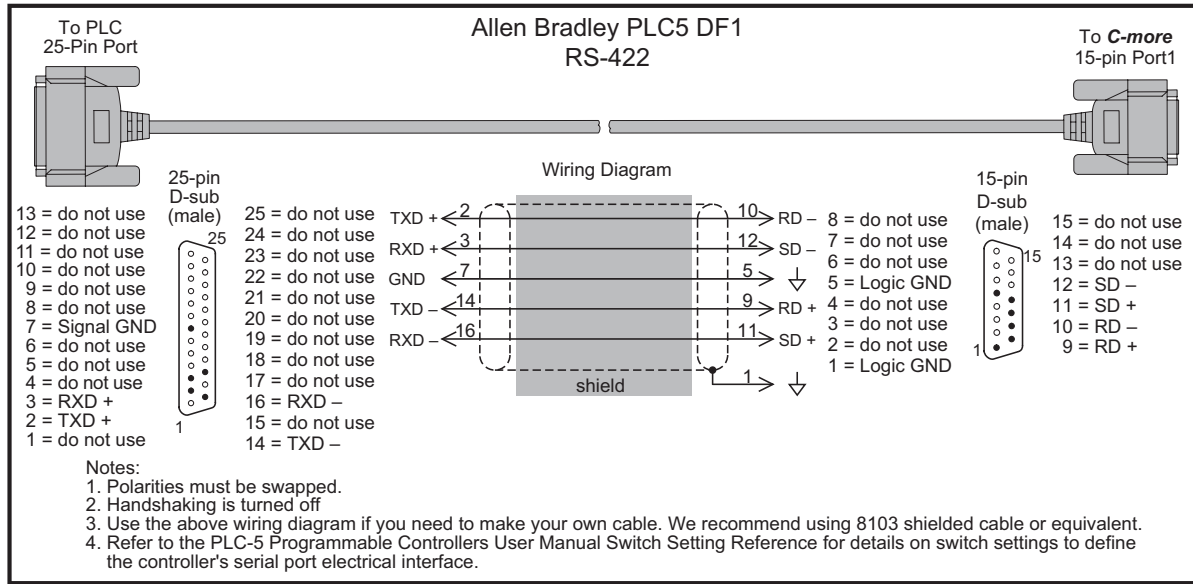

GE PLCs RS-422/RS-232C Serial Cables Wiring Diagrams

The following series of wiring diagrams show the connectors and wiring details for the communication cables that are used between the **C-more** touch panels and GE PLC controllers. Part numbers are included with the pre-made cables that can be purchased from AutomationDirect. The information presented will allow the user to construct their own cables if so desired.

EA-90-30-CBL

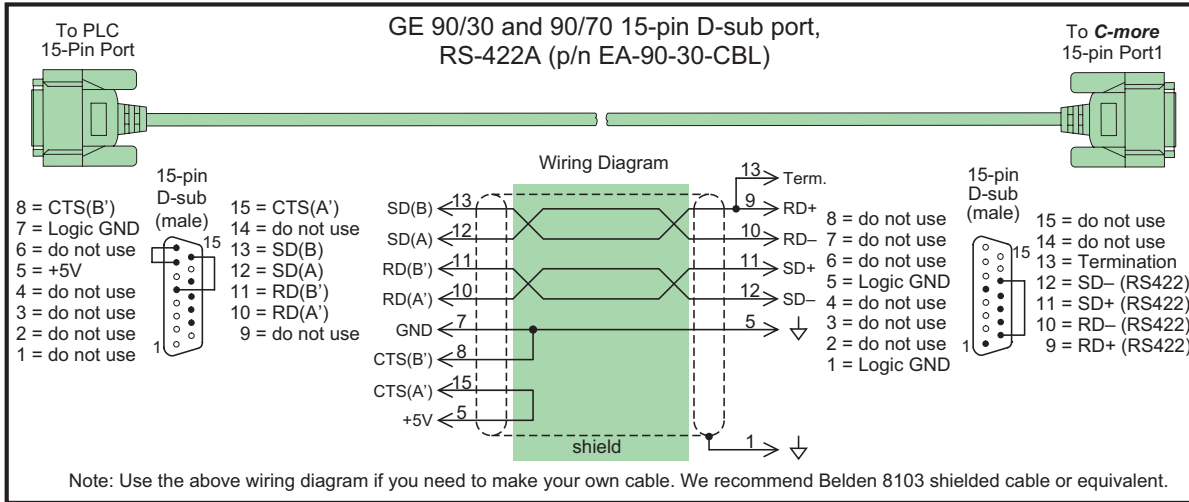

User Constructed

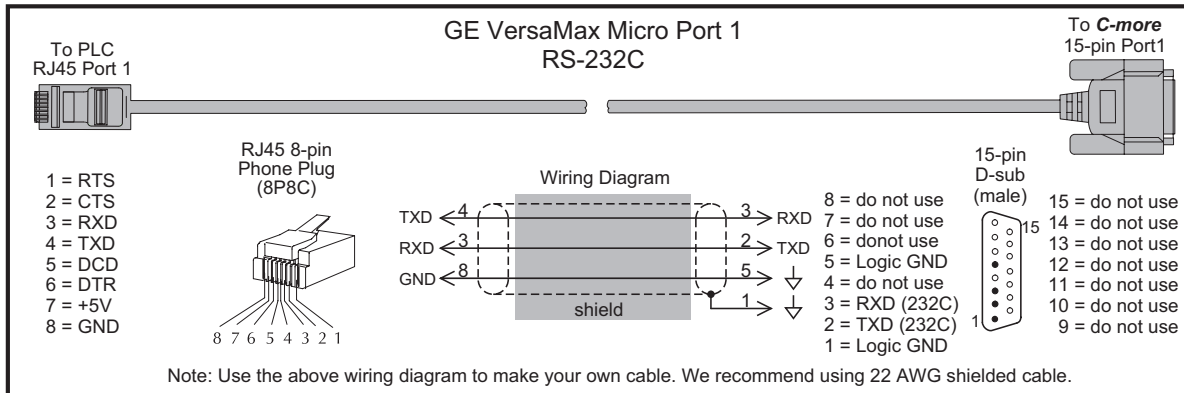

Mitsubishi PLCs RS-422/RS-232C Serial Cables Wiring Diagrams

The following series of wiring diagrams show the connectors and wiring details for the communication cables that are used between the **C-more** touch panels and Mitsubishi PLC controllers. Part numbers are included with the pre-made cables that can be purchased from AutomationDirect. The information presented will allow the user to construct their own cables if so desired.

EA-MITSU-CBL

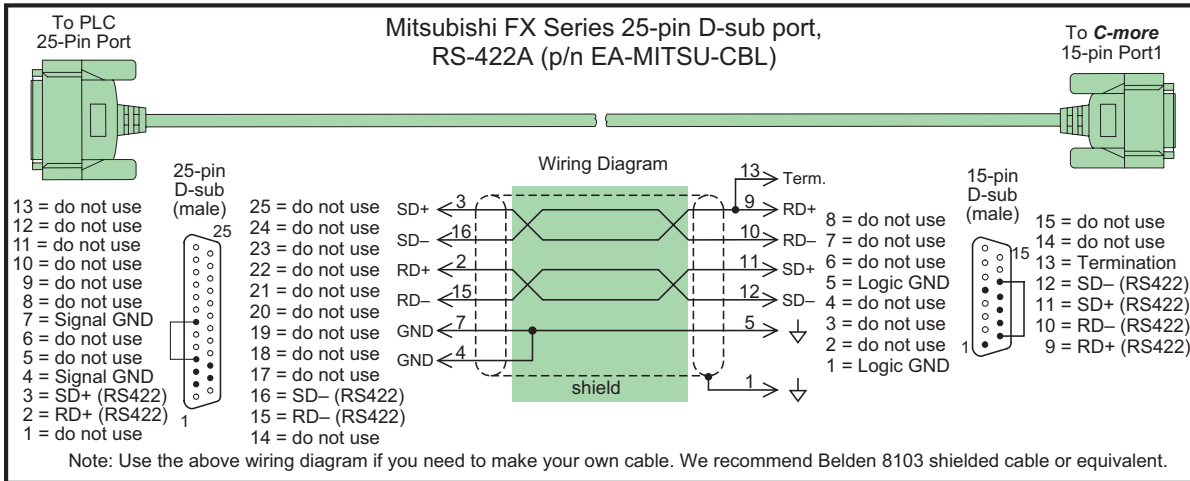

EA-MITSU-CBL-1

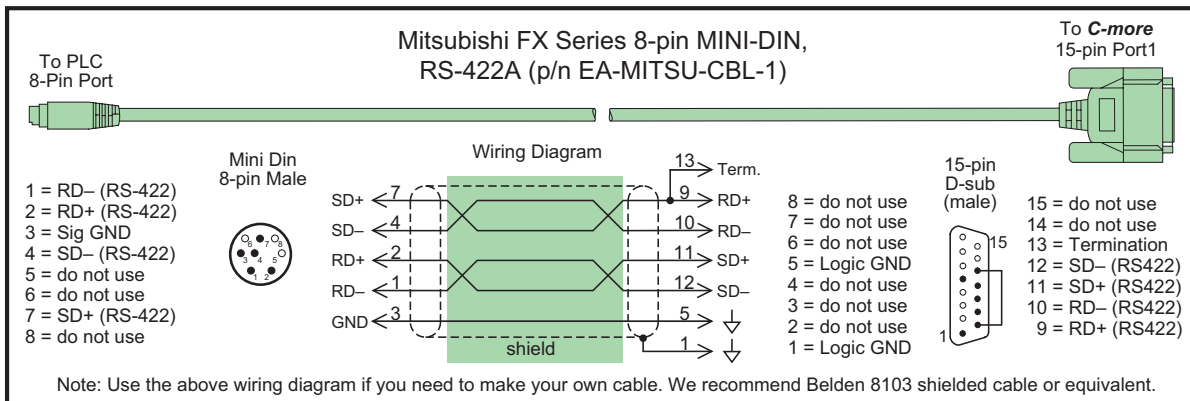

User Constructed

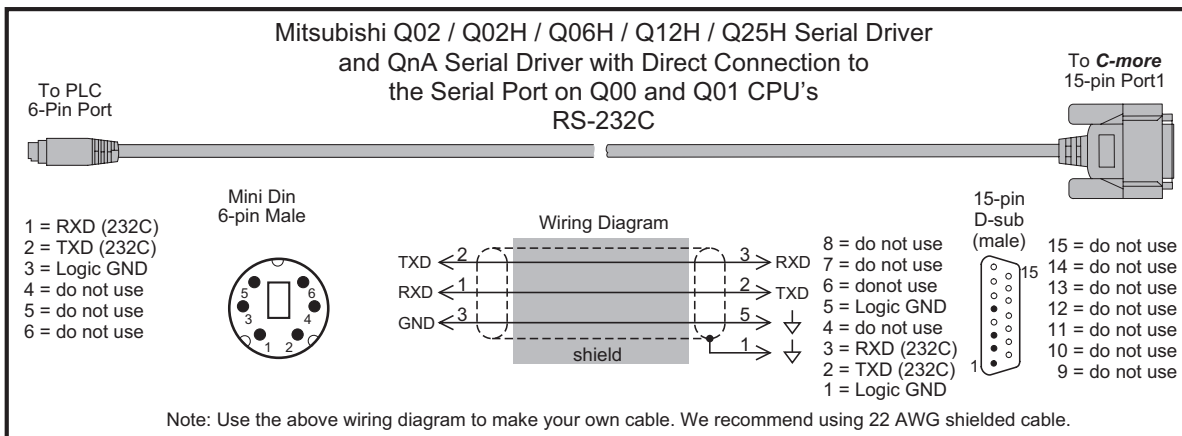

User Constructed

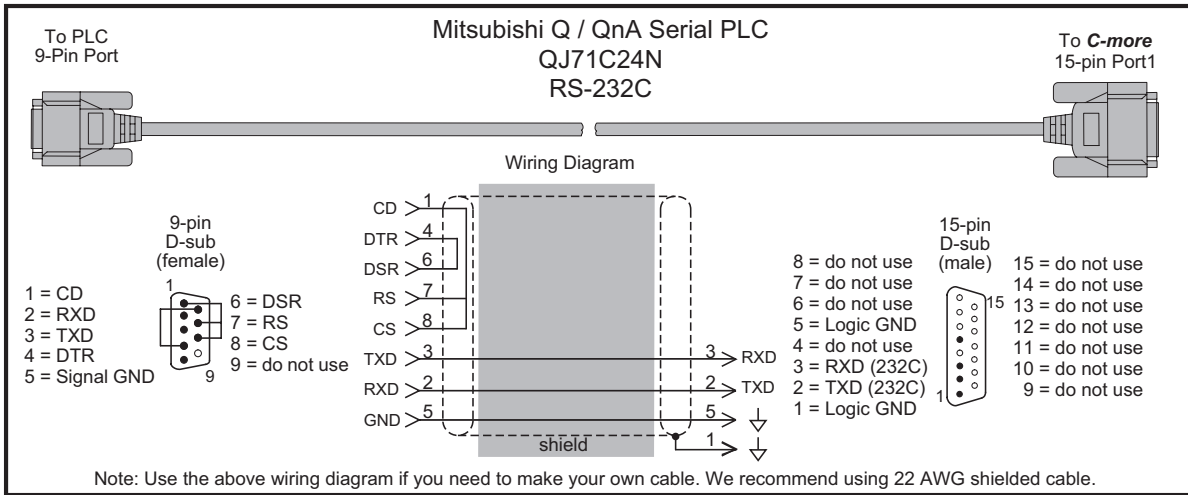

Omron PLCs RS-232C Serial Cables Wiring Diagrams

The following series of wiring diagrams show the connectors and wiring details for the communication cables that are used between the **C-more** touch panels and Omron PLC controllers. Part numbers are included with the pre-made cables that can be purchased from AutomationDirect. The information presented will allow the user to construct their own cables if so desired.

EA-OMRON-CBL

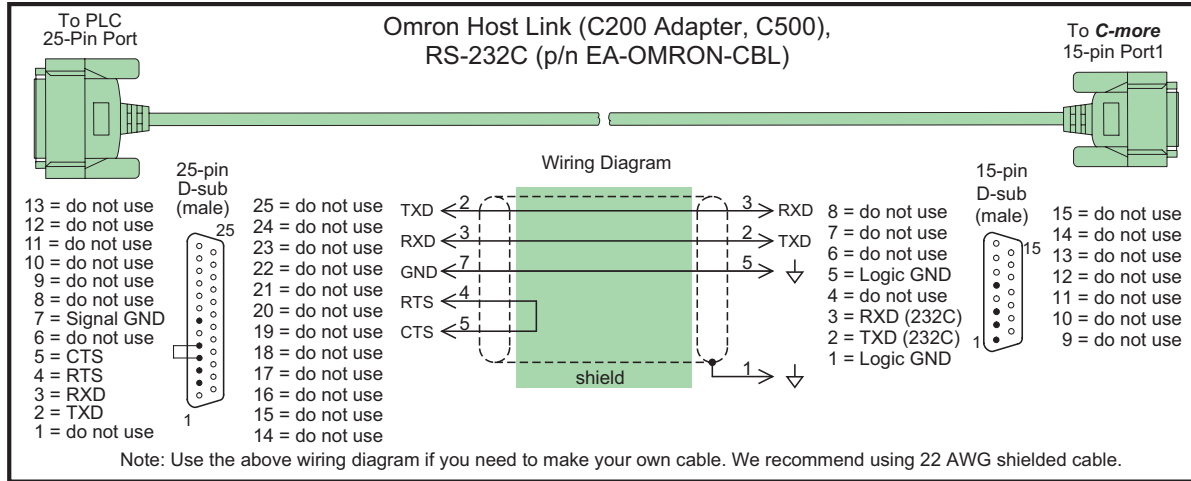

User Constructed

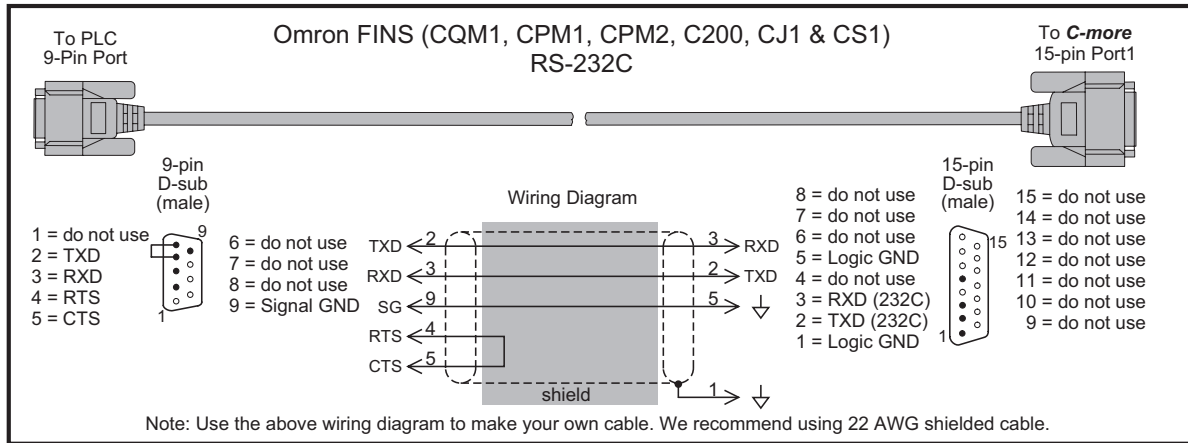

User Constructed

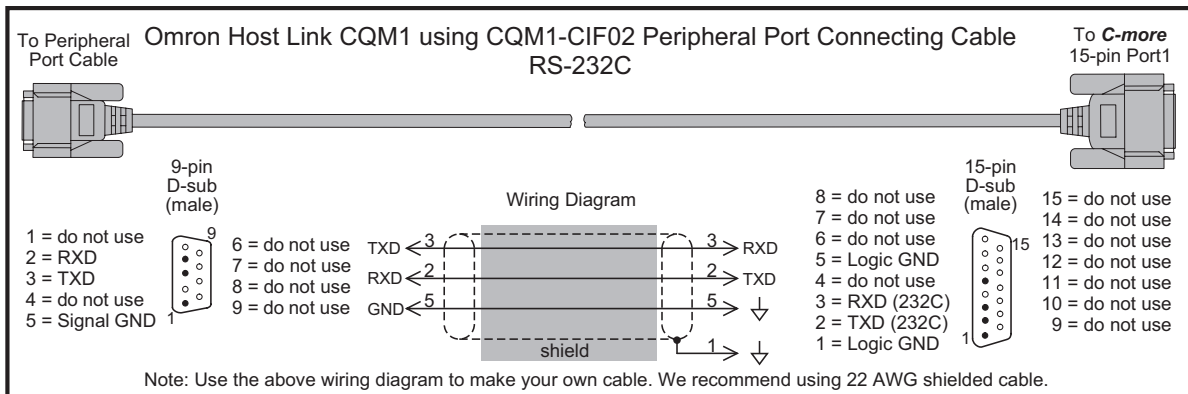

Modicon PLCs RS-232C Serial Cables Wiring Diagrams

The following series of wiring diagrams show the connectors and wiring details for the communication cables that are used between the **C-more** touch panels and Modicon PLC controllers. The information presented will allow the user to construct their own cables.

User Constructed

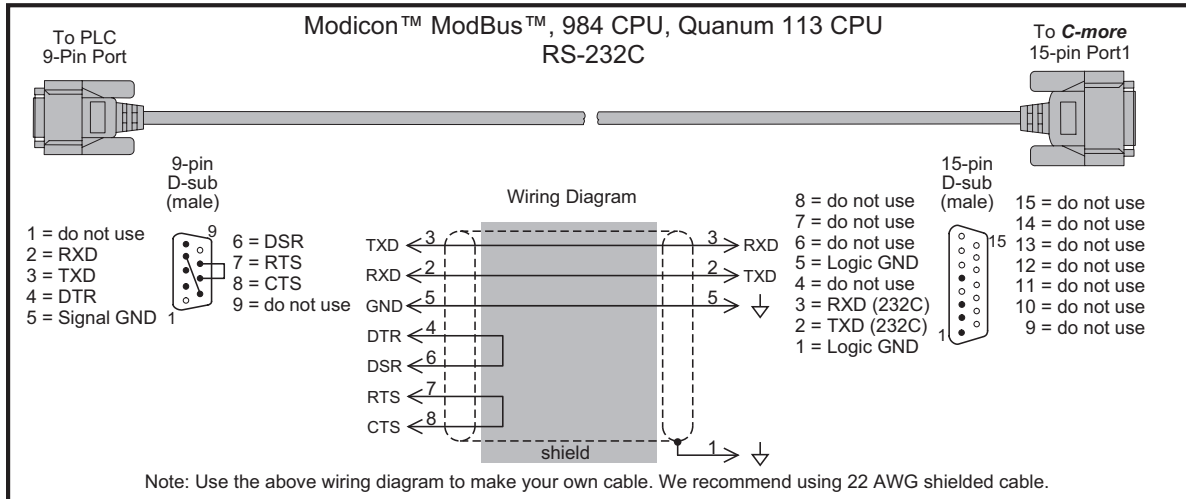

User Constructed

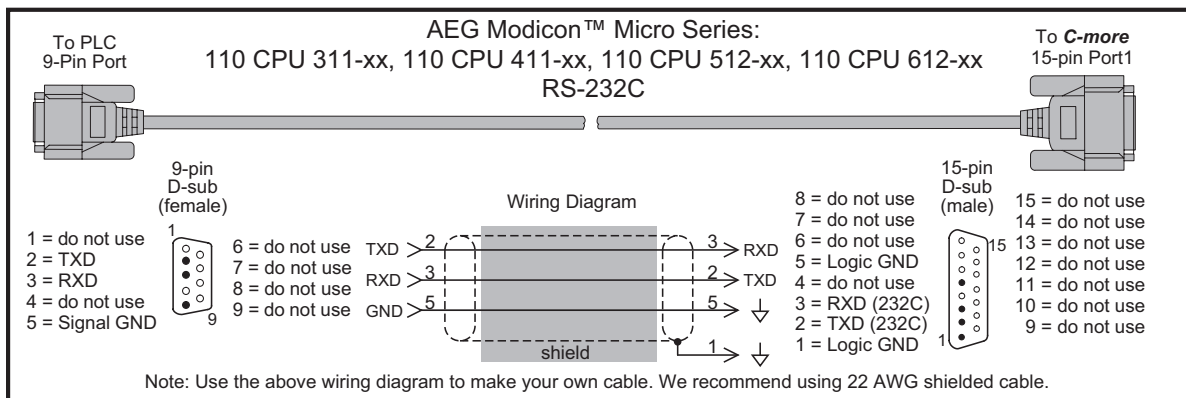

User Constructed

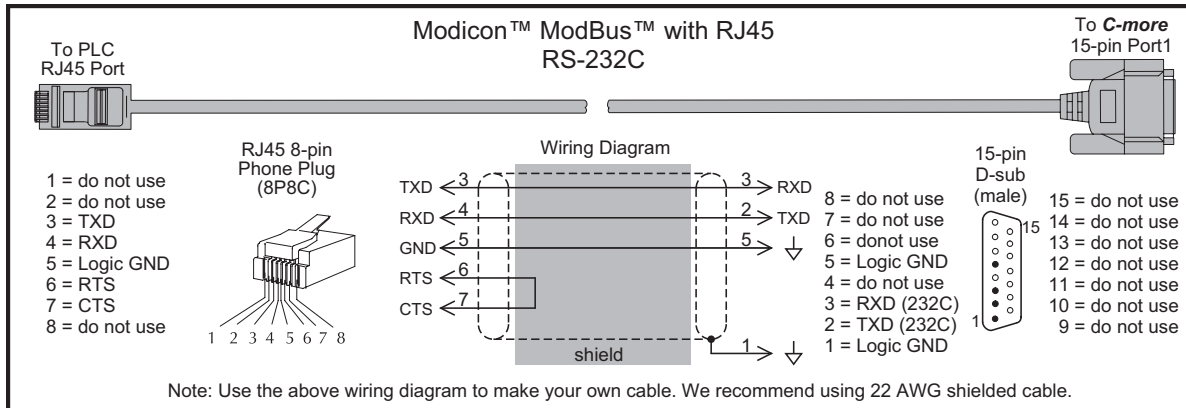

Siemens PLCs RS-485A Serial Cables Wiring Diagrams

The wiring diagram below shows the connectors and wiring details for the communication cable that may be used between the **C-more** touch panel and Siemens PLC controller. The information presented will allow the user to construct their own cable.

User Constructed

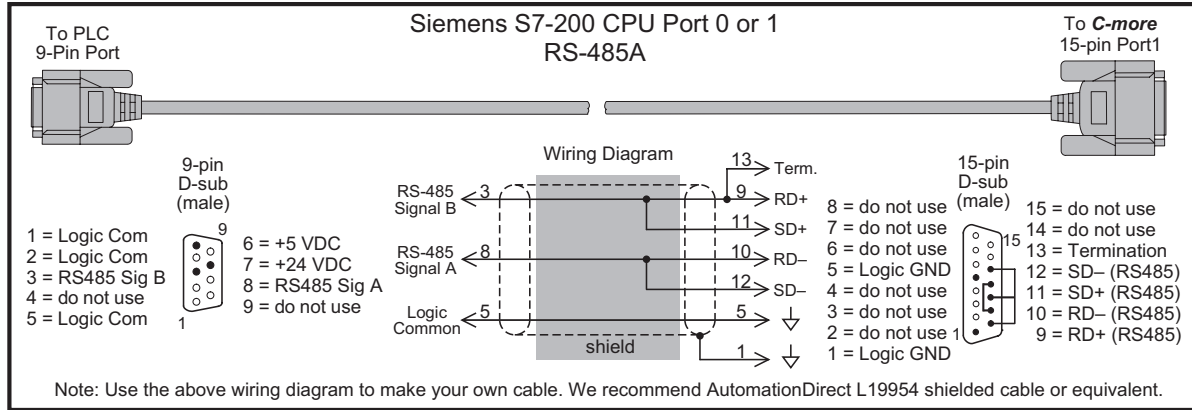

**BLANK
PAGE**

MAINTENANCE



CHAPTER

7

In This Section...

Maintenance	7-2
Project Backup.....	7-2
Check Operating Environment.....	7-2
Check Operating Voltage.....	7-2
Check Status Indicators.....	7-2
Check Physical Conditions	7-2
Run Tests under System Setup Screens.....	7-3
Check Memory Usage	7-4
Check Error Log.....	7-4
Check Project Functionality	7-5
Checks from <i>C-more</i> Programming Software	7-5

Maintenance



Although the **C-more** touch panels require very little maintenance, setting up a routine maintenance schedule will ensure the longevity of the product in your application.

The following are some suggestions of items to include in a preventive maintenance list or schedule. Most of these items should be scheduled quarterly or semi-annually.

Project Backup

During routine preventive maintenance is a good time to make sure that there is an up-to date backup of the application project. Although the **C-more** touch panel has the ability to upload the complete project from a panel through the programming software, insurance is warranted just in case the worse case scenario happens and the entire touch panel is destroyed.

Check Operating Environment

- Make sure the touch panel is operating in the proper temperature range: 0 to 50 °C (32 to 122 °F).
- Make sure the touch panel is operating within the specified humidity range: (5 – 95% RH, non-condensing).

Check Operating Voltage

- Check the DC input voltage that is powering the touch panel to make sure it is within 10.2-26.4 VDC.

Check Status Indicators

- During routine maintenance is a good time to take a quick look at the status indicators on the front of the CM5-RHMI. The Power LED (PWR) indicator should be on and there should be activity on the TxD and RxD LED indicators when connected serially to a PLC or control device. Check the status of the CPU LED and compare it to the chart shown in the illustration below. Any indication of the CPU LED other than a solid green shows there is a possible problem, and the condition needs to be corrected.

Check Physical Conditions

- Make sure that harmful chemicals are not being used around the panel. Look for any deterioration of the touch panel's bezel and front display area.
- Check the mounting gasket to make sure it is sealing properly and has not deteriorated. Replace the mounting gasket if there are any signs of deterioration, or if there is any evidence that moisture/liquids have penetrated to the inside of the enclosure where the panel is mounted. Information on a replacement gaskets can be found in **Chapter 9: Replacement Parts**.
- Check to make sure that none of the cooling vents around the inside section of the touch panel are clogged with dust or debris. Also make sure that there is clearance around the touch panel as shown in **Chapter 4: Installation and Wiring**.

Run Tests under System Setup Screens

- Use the touch panel's System Setup Screens to test the touch screen, display, communication ports, beeper and audio output (only with external amplifier and speaker(s) connected). See **Chapter 5: System Setup Screens** for additional details for the Test

Test Touch Panel - allows the user to check the analog touch function of the screen by drawing free hand lines and shapes across the entire touch area. The display will retain the lines where the screen has been touched until the **Close** button is pressed.

Test Display - used to test the display and color rendition. A test pattern will first show both the primary colors and a gray scale. If the touch screen is not pressed within a few seconds, the display will go into alternating color sweeps across the screen until the panel is pressed again. If the screen is pressed when the test pattern first appears, it will stay in this mode until the **Close** button is pressed.

Test Serial Port - used to test the functionality of the 15-pin PLC communication serial port, the 3-wire terminal block RS-485 port, the RJ12 RS-232 port. A loop-back connector can be fabricated and used on the serial ports to test the RS-232 or RS-422/485 communications for the TxD and RxD signals and also the RTS and CTS signals if applicable. The **Test Serial Port** setup screens and **Chapter 5** show pin-outs for the RS-232 and RS-422/485 loop-back connectors.

Test Ethernet Port - The Ethernet connection can also be tested for communications if it is at least connected to an Ethernet switch. If the touch panel is connected to a PLC, then an inquiry test can also be done to test the communications between the panel and the PLC. Press the **Close** button when finished to return to the **Test Menu**.

Test Beep/Sound - used to test the touch panel's internal beeper and also test the audio with a USB to Audio adapter and external amplifier and speaker(s) connected. Testing the audio output is done by playing an included internal WAV file. Press the **Close** button when finished to return to the **Test Menu**.

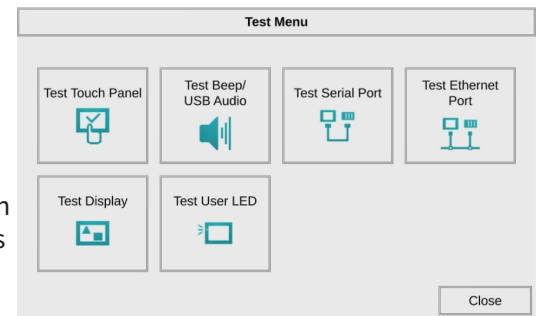

Check Memory Usage

- A good time to check and record the touch panel's memory usage for future reference is during a routine maintenance schedule. The various memory devices being used by the panel are listed under the tab. This includes internal memory as well as any external memory device such as a USB pen drive or SD card memory. If no external memory device is inserted, it will not show up on the list.
- The memory usage can be viewed by use of the panel's **System Setup Screen's Main Menu**, and then selecting the Information button then the Memory tab. See Chapter 5: System Setup Screens for additional details on using the Memory tab.

Information					
General	Memory		Ethernet	Error	License
	Total	Used	Free		
SDRAM:	428.7 MB	343.9 MB	84.8 MB		
SRAM:	512.0 KB	124.0 KB	388.0 KB		
Built-in Flash:	3.3 GB	1.4 GB	1.9 GB		
SD1:	1.8 GB	1.2 MB	1.8 GB		

Close

Check Error Log

- Another good practice is to review the touch panel's **Error Log**. The log can be viewed by use of the panel's **System Setup Screen's Main Menu**, and then selecting the **Information** button. Look under the **Error** tab. See **Chapter 5: System Setup Screens** for additional details on using the **Error** tab, **Appendix A: PLC Protocol Error Codes** for a list of the error codes as they relate to the specific PLC that is being used with a description of the error, and **Appendix B: Touch Panel Runtime Errors** for a list of errors that may occur when the panel is in operation.

Information				
General	Memory	Ethernet	Error	License
No	Time	Code	Error Message	
1	02/21/23 05:04:29	PLC-001	PLC Communication Timeout (ETHERNET.DEV001,RC	
2	02/21/23 05:04:19	PLC-001	PLC Communication Timeout (ETHERNET.DEV001,RC	
3	02/21/23 05:04:09	PLC-001	PLC Communication Timeout (ETHERNET.DEV001,RC	
4	02/21/23 05:03:59	PLC-001	PLC Communication Timeout (ETHERNET.DEV001,RC	
5	02/21/23 04:51:20	PLC-001	PORT2 - PLC Communication Timeout (COM2,PORT2	
6	02/21/23 04:51:19	PLC-001	PORT2 - PLC Communication Timeout (COM2,PORT2	
7	02/21/23 04:51:19	PLC-001	PORT1 - PLC Communication Timeout (COM1,PORT1	
8	02/21/23 04:51:18	PLC-001	PORT2 - PLC Communication Timeout (COM2,PORT2	
9	02/21/23 04:51:17	PLC-001	PORT2 - PLC Communication Timeout (COM2,PORT2	
10	02/21/23 04:51:16	PLC-001	PORT2 - PLC Communication Timeout (COM2,PORT2	
11	02/21/23 04:51:16	PLC-001	PORT1 - PLC Communication Timeout (COM1,PORT1	

Check Project Functionality

- During routine maintenance is a good time to check the functionality of your application, making sure that various areas on different screens do what they were designed to do. An outline or specification for the application is a useful tool for testing the various aspects of your application. As a starting point, you may want to run through all the screens to make sure they are accessible.
- If there are any trouble-shooting procedures built into the touch panel application, now is a good time to also check these aids.

Checks from C-more Programming Software

- If you have a PC available with the **C-more** programming software, CM5-PGMSW, installed, and the PC is connected to the touch panel, there are checks you can make to the status of the touch panel by using the **Panel Information...** feature located under the **Main Menu** heading **Panel**. This includes the following:
 - Connected panel details
 - Memory availability and usage
 - Revisions

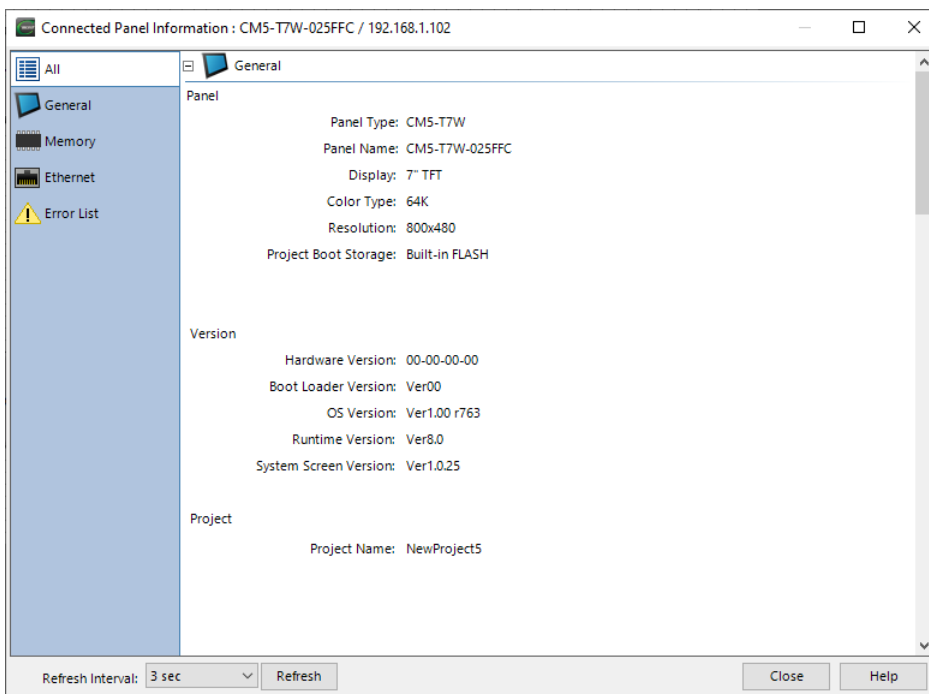

- Other functions that can be accessed from the programming software directly to the touch panel include: **Display Screen**, **Reboot**, **Adjust Clock**, **Memory Clear**, and **Update Firmware**. Additional information for these functions can be found in the **C-more** programming software online help file.



In This Chapter...

Common Problems.....	8-2
Troubleshooting Flow Chart.....	8-3
HMI Does Not Power Up	8-4
<i>C-more</i> LED Status Indicators	8-5
General Errors and Warnings.....	8-6
CM5-RHMI Beep.....	8-6
Display is Blank.....	8-7
No User Program	8-8
Touch Screen Does Not Work.....	8-9
Select Touch Panel Driver	8-10
Safe Mode Recovery	8-14
Safe Mode (ERR-202-5)	8-15
USB Driver Troubleshooting.....	8-16
No Communications between Panel and PC (Personal Computer)	8-17
No Communications Between Panel and PC (Personal Computer) via USB	8-23
No Communications Between Panel and PC (Personal Computer) via Ethernet	8-25
No Communications between Panel and PLC	8-26
IP Address in System Setup Screens Displays 0.0.0.0.....	8-30
Difficulty Connecting to the Panel over the Internet (Web Server and Remote Access Features)	8-31
PLC Protocol Error Codes	8-32
HMI Runtime Errors.....	8-33
Panel Constantly Displays “Initializing” when Powering Up	8-34
Data Not Logging Problems.....	8-34
Electrical Noise Problems.....	8-35
Touch Screen Not Working	8-35



The following topics are some of the more likely problems that may be encountered during the installation and operation of your **C-more** HMI. We have made some suggestions on what to check in order to correct the problem. Please start with the troubleshooting flow chart that covers the more common problems encountered by other users.

Common Problems

The troubleshooting flow chart shown on the following page is based on the more common problems fielded by our technical support team. Then, if you are having problems, please start with the flow chart and follow the suggestions listed. and if you still need help, call our tech support team @ 770-844-4200. In addition to having ready the information suggested in the flow chart, please have the following available:

- 1) **C-more** HMI part number including serial number with date code.



NOTE: The “About C-more Programming Software...” dialog box will show a Firmware version. This is the current firmware version that is included with the programming software and does not reflect what firmware is actually loaded on your C-more HMI. See the following for details on how to check the firmware version.

- 2) Programming software version that you are currently using. For example: Version 5.20. Having the software version number will allow our tech support team member to assess whether there are similar problems that have been reported when using the same version of the software. The programming software version can be found by clicking on “**About C-more Programming Software...**” selection under the **Help** pull down menu in the software. Also, it is always a good practice to visit the **Software/Firmware Downloads** area under the Tech Support section of the **AutomationDirect** website and check to see if you are using the latest version of the programming software. If you aren’t using the latest software version, we suggest that you upgrade to see if this resolves your problem.
- 3) Firmware version of the **C-more** HMI. For example: V5.20. The firmware version can be checked by using the **System Setup Screens**, going to the **Information** menu under the **Main Menu**, and looking under the **General** tab for **Firmware: -Runtime**. The firmware version can also be checked by using the programming software, while connected to the panel, and clicking on the **Panel Information** selection under the Panel pulldown menu. As with the programming software version, it is important for our tech support associates to know which firmware version you are using so they can check on any known problems. As with the programming software, we strongly suggest that the firmware be updated to the latest version. Check for the latest version and download from the **Software/Firmware Downloads** area of the **AutomationDirect** website.

It is also helpful to have a copy of your project file for our tech support associates to use in troubleshooting a problem, so please be prepared to forward a copy of your project if it is requested.

Troubleshooting Flow Chart

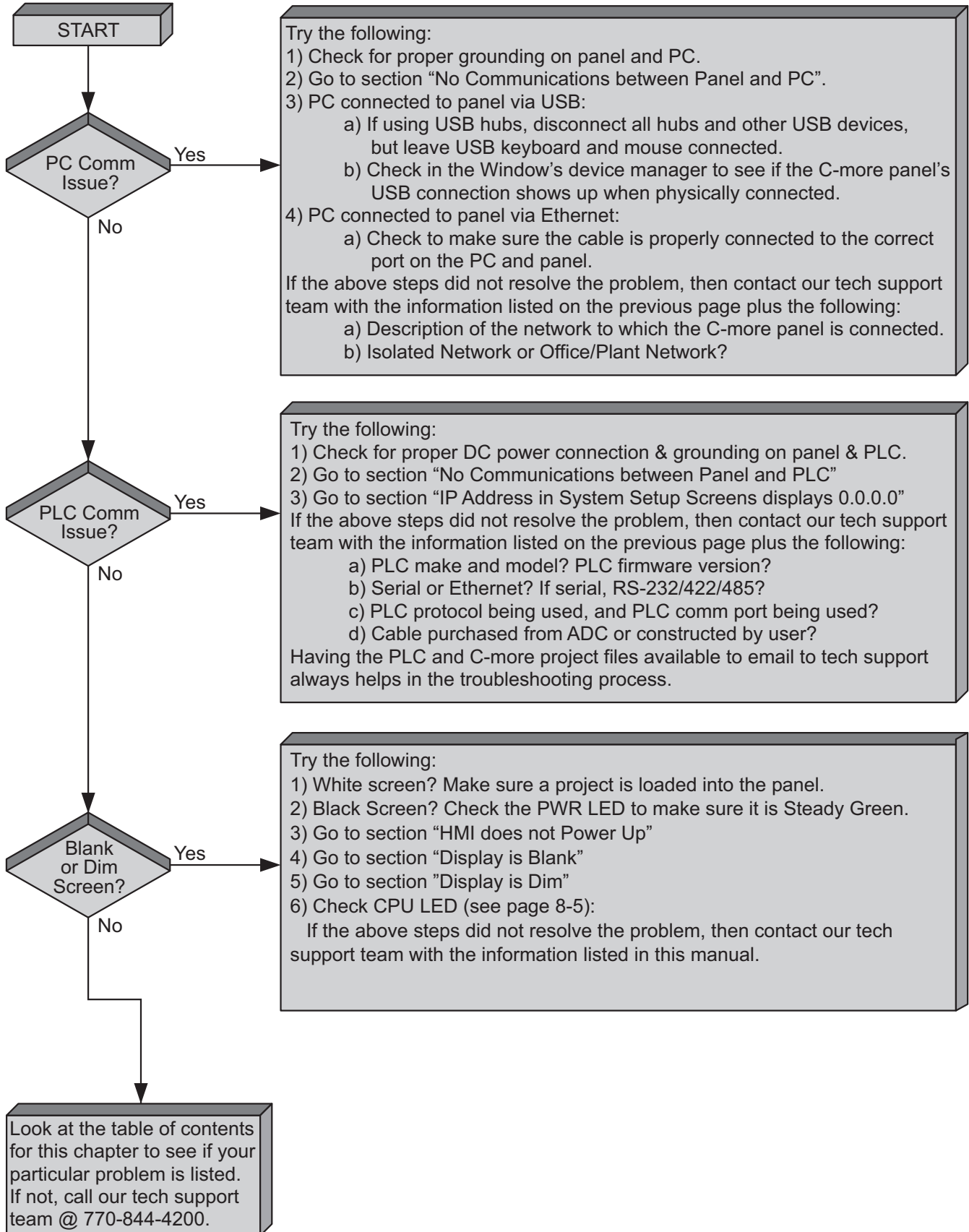

HMI Does Not Power Up

- 1.) Check the status indicators on the front of the panel to see if the **Power LED (Green)** indicator is on. Refer to the diagram below. If the **Power LED (Green)** indicator is on and the panel was observed showing “Initializing...” during power up, but the display is now blank, go to the next troubleshooting tip, **Display is Blank**.
- 2.) If the **Power LED (Green)** indicator is off and the panel is being powered with a 12 or 24VDC power source, use a voltmeter to check the incoming DC voltage level. If the incoming DC voltage is zero, check any fusing that may be in the circuit. If the fuse is open, determine cause and replace. If the DC voltage level is out of range, the DC power source needs to be corrected or replaced.

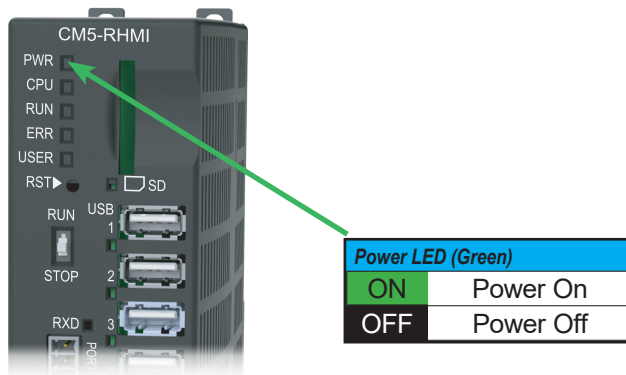

C-more LED Status Indicators

The status indicators will show activity whether the serial communications is wired for RS-232 or RS-422/485.

Electrical noise, pulse generating wiring and/or improper grounding can also cause problems with communications. Refer to the **Electrical Noise Problems** section later in this chapter for additional help.

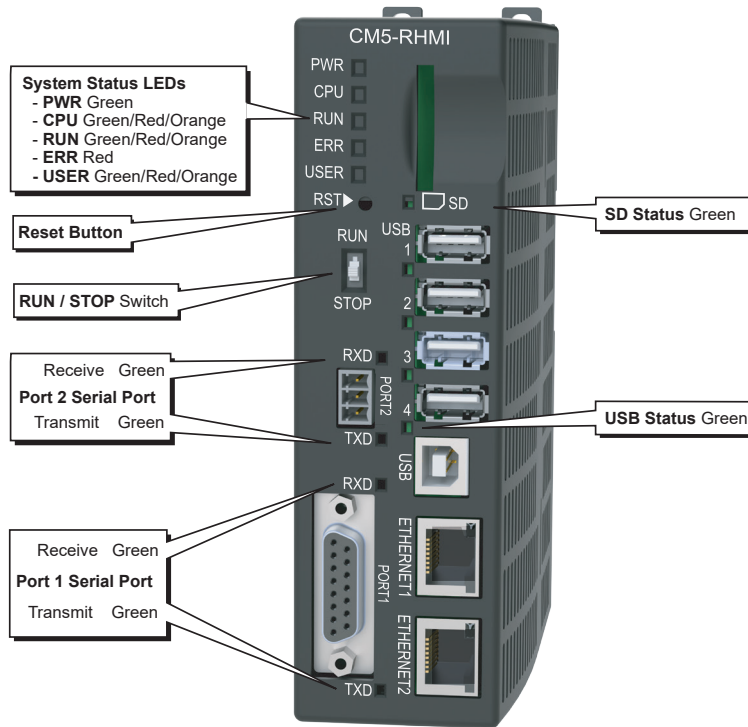

System Status LEDs				
	LED	CPU	RUN	ERR
State	Loading Project	–	Blinking Green (0.2s)	–
	Loading OS	Blinking Green (0.5s)	–	OFF
	CPU Running Normally	Green	–	OFF
	Project Loaded and Running	–	Green	–
	No User Project	–	Orange	–
	Reset to Factory Default	Blinking Green (0.5s)	Blinking Green (0.5s)	Blinking Red (0.5s)
	System Screen	–	OFF	–
	Password Required	–	Blinking Orange (0.5s)	Blinking Red (0.5s)
	Errors	Power Loss Detection	Blinking Orange (0.2s)	–
Memory Error		Red	OFF	Red
OS Error		Blinking Orange (0.5s)	OFF	Red
No Log Storage Found		–	Blinking Orange (0.5s)	Blinking Red (0.5s)
General Error*		–	Red	Blinking Red (0.5s)
Warning*		–	Blinking Orange (0.5s)	Blinking Red (0.5s)
Safe Mode		Orange	OFF	Red

*Note - See Chapter 8 – Troubleshooting for General Error and Warning explanations.

General Errors and Warnings

There are multiple causes for general errors and warnings. To get specific information for a general error and warning, connect the CM5-RHMI to a PC via USB. See Chapter 5 - System Setup Screens, Using RHMI USB Remote for more information.

- **General Errors**

- This file is not in a recognizable format
- Unsupported file version
- Not enough buffer memory
- Not enough memory to show all data points for trends
- Error in reading the file
- Multiple projects found in panel

- **Warnings**

- MRAM memory check sum error
- **C-more** runtime has detected corrupt data
- RUN --> STOP w/ Password
- Boot in STOP w/ Password
- No log storage found. *Note* - Data will not be logged if 'Ignore' is pressed.
- **WARNING** - The panel will stop
- Memory device is write protected

CM5-RHMI Beep

Beep Functions	
Function	Beep Pattern
Boot	1-long, 2-short
Boot Error*	3-long
HDMI Connected	3-short
Reset to Factory Defaults	14 short beeps progressively closer together followed by 1-long beep.
Blink Screen	5-long
*Boot Errors Multiple Projects Write Protected SD Card No Log Storage Found Password Protected	

Display is Blank

- 1.) Touch the screen to make sure the panel is not in the **Screen Saver** mode.
 - The **Screen Saver** will be turned off and the panel screen will display:
 - If a **PLC Address** is configured to control the **Screen Saver** and changes from **On** to **Off**.
 - When a connected touchscreen panel is touched.
 - When the screen is clicked by **Remote Access**.
 - When the **Alarm Event** of the **Event Manager** occurs. (Only when the **Display** setting of the **Alarm Event** is checked).
 - When there is a screen change by the **PLC**.
 - When an **Error** such as a **Communication Error** occurs.
- 2.) If the panel is not in **Screen Saver** mode, check the LED status indicators on the front of the unit. Refer to **Chapter 4 - Installation and Wiring, C-more LED Status Indicators** for more information.
 - Make sure the **CPU status LED (Green, Orange, Red)** is a **steady Green**.
 - If the **CPU status LED** is **blinking Orange (ON for 0.2 sec)**, then the supply voltage is below 12VDC
 - A **blinking Orange CPU (ON for 0.5 sec)** status LED indicates that the operating system could not be found. Reload the firmware to the HMI. If this does not resolve the problem, the panel must be replaced.
- 3.) There is always the remote possibility that a project has been transferred to the HMI that includes a screen that uses a black background and has no objects placed on the screen. To check for this possibility, access the **Main Menu** of the HMI **System Setup Screens** by moving the RUN / STOP switch to the STOP position. If the **System Setup Screen's Main Menu** is displayed, then most likely an empty black background screen is being displayed.

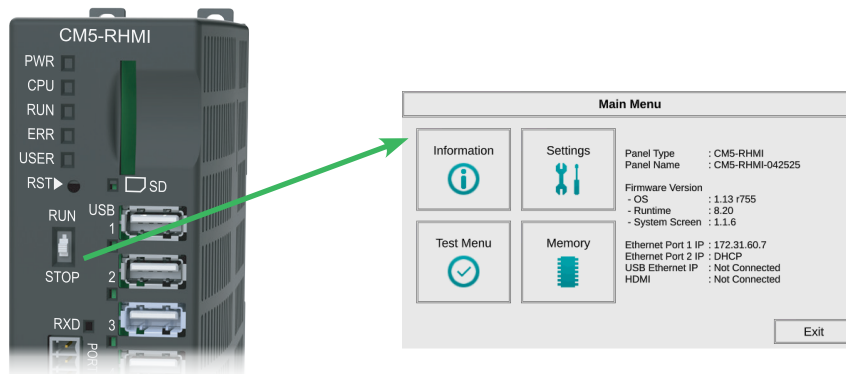

No User Program

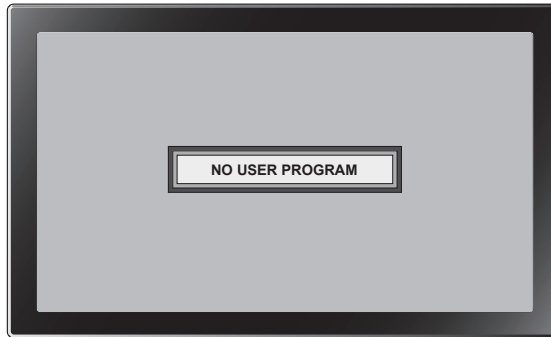

If a connected display is displaying the message “No User Program” after it has powered up, then either:

- the built-in Flash memory does not contain a recognized project, or
- an SD memory card is plugged into the SD1 slot, the project is set to boot from SD1 and there is no project on the SD memory card. Turn the power off, remove the SD memory card and turn the power back on.

Keep in mind that on power up, the HMI will read the project into the SDRAM memory from the location designated in the **Project Storage/Boot Location** setting in the in the **C-more** Software. This will either be the Built-in Flash memory or an SD memory card in the SD1 slot. If the location designated has no project, the upon power up or reboot NO USER PROGRAM will be displayed even if a project resides in the other location.

Touch Screen Does Not Work

Make sure you're using a monitor with a compatible touch screen.

The **C-more** CM5-RHMI supports most HID compatible Resistive and pCap touchscreens starting with firmware version 8.20. The manufacturers and models that have been tested at the time of firmware version 8.20 release are:

CM5-RHMI Compatible Touch Screen Monitors		
Manufacturer / Distributor	Models	Touchscreen Type
Adlink	OM-215	pCap
Advantech	FPM-221W	pCap
Advantech	IDS-3215	Resistive
Atlas	ATM1500T	Resistive
Atlas	ATM1700T	Resistive
Atlas	ATM1900T	Resistive
Dynics	FX15PTUMAD	Resistive
ELO	E382790	SAW
ELO	ET1593L	pCap
Hope	HIS-ML15CTBH	Resistive
Hope	HIS-ML19.5CTBA	Resistive
Hope	HIS-ML19.5FPVB	pCap
Hope	HIS-ML19CTBH	Resistive
Hope	HIS-ML23-CTBD	pCap
HP	E24T G5	pCap
TruVu	VMTR-15C	Resistive
TruVu	ZBMT-18.5R	Resistive
ViewSonic	TD2465	pCap

Select Touch Panel Driver

When the touchscreen is connected to the panel, the panel attempts to negotiate the proper driver. If the touchscreen does not respond, the panel may have selected the incorrect driver. Select Touch Panel Driver opens the screen below.

The screen below is shown with up to three Drivers, Driver #1, Driver #2, and Driver #3. Select each driver in turn and the Check Touch Panel screen opens.

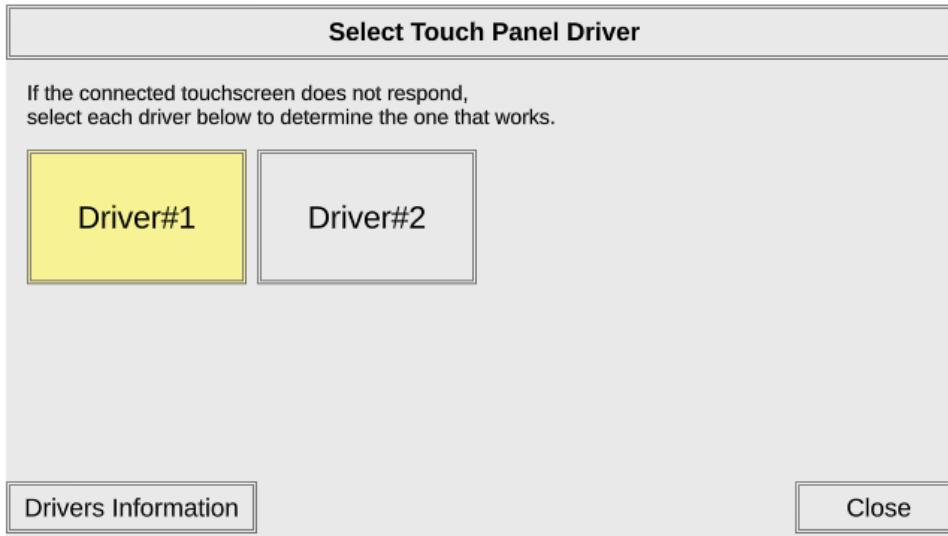

Touch the screen 3 times within 10 seconds.

- If the touch is registered, then the driver is used.
- If the touch is not registered, the screen will timeout.
- If this occurs, select the next driver and follow the same process.
- If all drivers have been selected without success, this indicates the panel does not have a driver for the selected touchscreen.

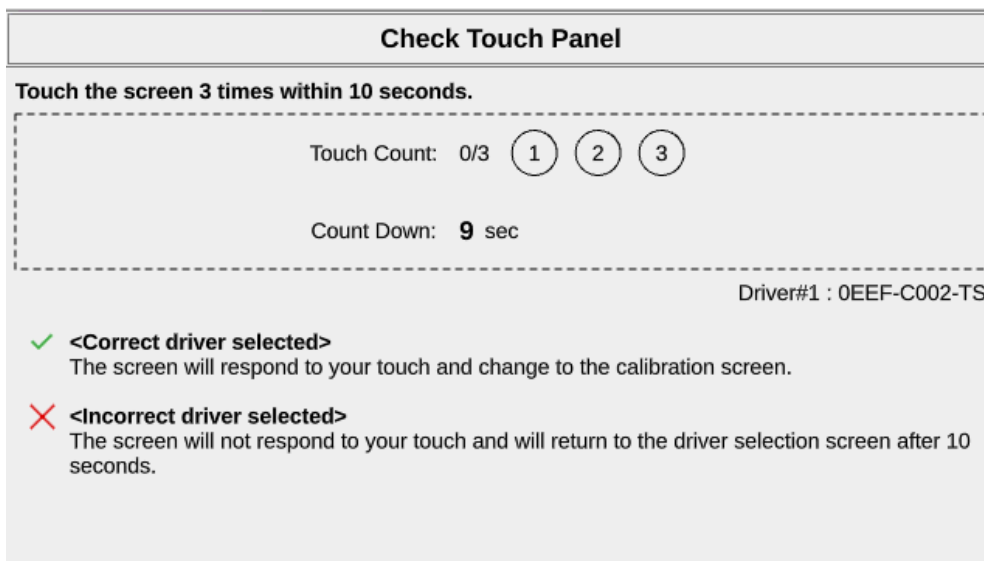

Reporting Unsupported Driver to AutomationDirect

With the correct driver information, you can attempt add the driver to the panel firmware for a later release.

- 1) Select the Drivers Information button.
 - *The Touch Panel Drivers Information window opens as shown below.*
- 2) Record the information for all drivers displayed.
- 3) Contact Technical Support and provide this information to them.
 - *There is no guarantee the driver can be added, and the time required may not be feasible for your project. You may consider trying a different touch panel monitor.*

Touch Panel Drivers Information			
Driver	PID	Vender ID	Type
Driver #1	0EEF	C002	TOUCH SCREEN
Driver #2	0EEF	C002	MOUSE

Calibrating the Touch Screen

Touch Panel Calibration Screen will open. Select all five calibration points (crosshairs) as they appear. Select them carefully and use a stylus if necessary for accuracy.

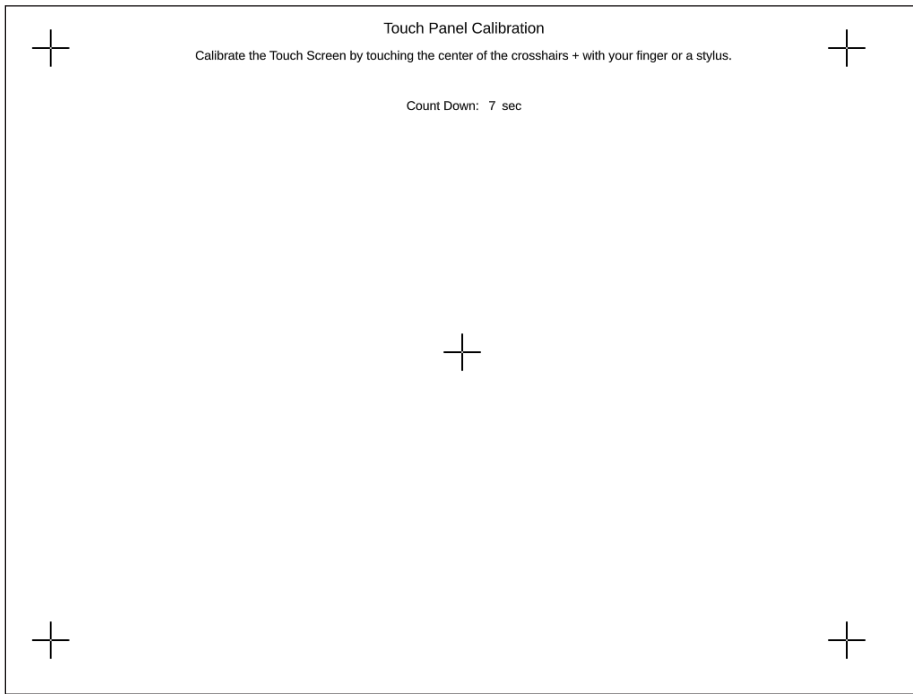

Touch Screen Calibration is Not Correct

If the cursor does not move to the point you touch, calibrate the touch screen using a USB mouse. Follow these steps for proper calibration.

Switching the panel from Run to Stop will sometimes force a touchscreen calibration.

If it does not, then Reset Factory defaults will clear the calibration settings and load the default. You can Reset Defaults from the software Panel tab or by holding down the reset button for more than 15 seconds.

Switching to Stop Mode after Resetting factory defaults will open the Call Calibration Screen shown below. You have 10 seconds to select the screen and go to the screen calibration.

If this process does not work:

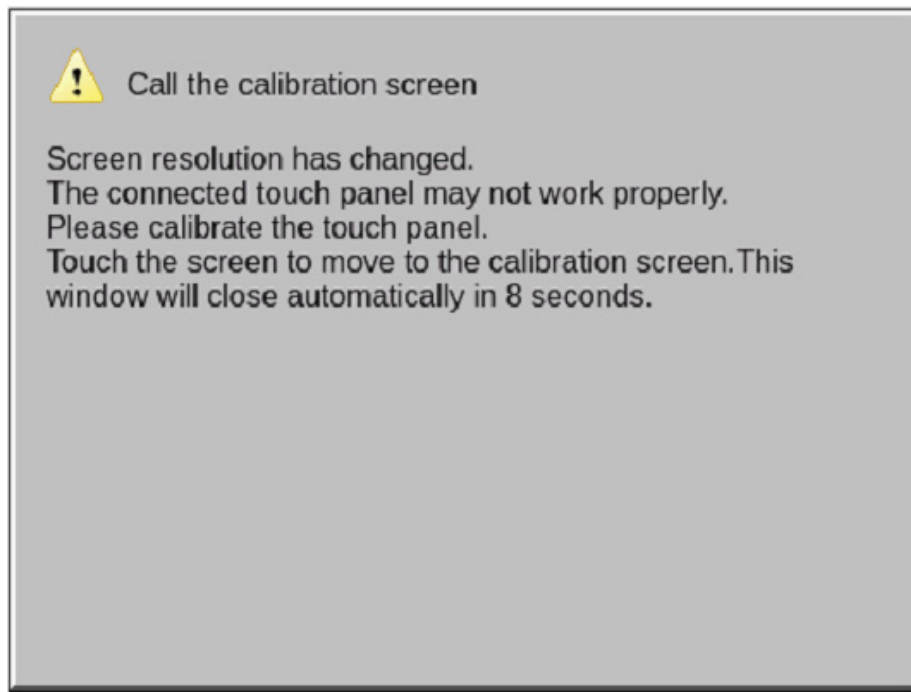

- 1) Move the CM5-RHMI RUN/STOP switch to STOP to access the System Screen.
- 2) Connect a USB mouse to one of the USB type A ports on the CM5-RHMI. The cursor should follow the mouse movement.
- 3) Use the mouse to access the Calibration screen. From the Main Menu select Settings, Touch Panel Touch Panel and Start Calibration.
- 4) From the Calibration screen, use your finger, not the mouse to touch each calibration crosshair as they appear. When all five points are touched, select OK to accept or Cancel.

Safe Mode Recovery

If the panel power is interrupted during a firmware update, the firmware in the panel may become corrupt. If the firmware is corrupt, but the operating system is still intact, the screen below will open when power is reapplied to the panel. This is called Safe Mode

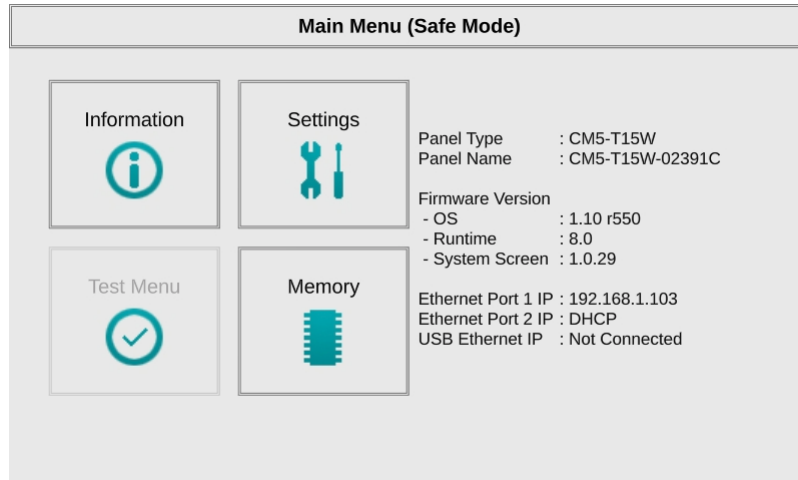

To recover, start the firmware update again making sure that there is a constant clean power supply.

Safe Mode (ERR-202-5)

If the Firmware Update process is interrupted, the panel may reboot into **Safe Mode**. **ERR-202-5: Safe Mode is activated** will be displayed as shown below. If this happens, the following screen will appear on the panel.

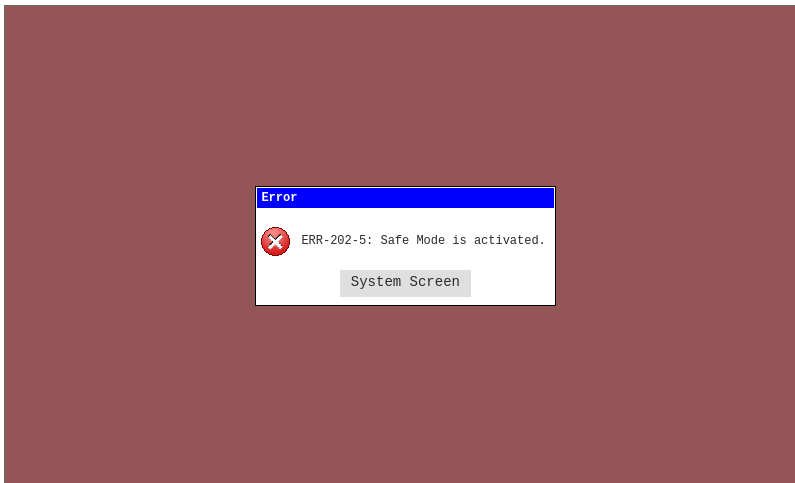

Select the System Screen button to open the System Screen on the panel.

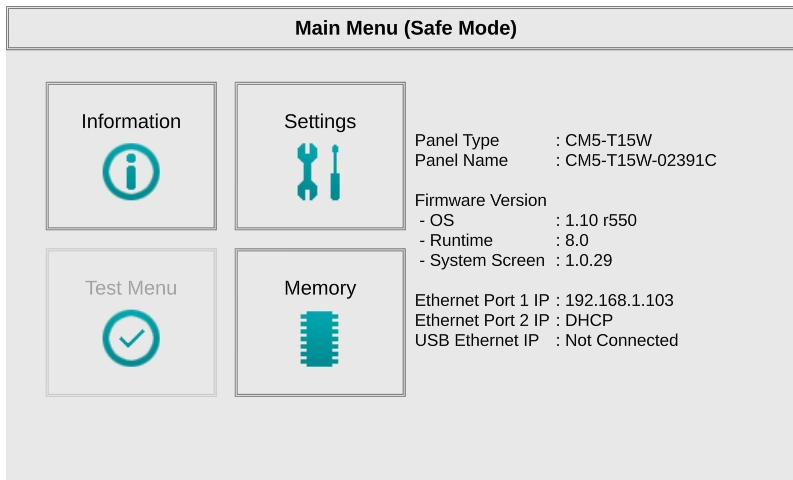

Notice some features are not available.

To recover the **C-more** panel, first eliminate the cause of the original failure (i.e. - whatever caused the firmware update failure like a loose cable connection or a power failure during update). Connect to the panel either by USB or Ethernet. Using the **C-more** software v8.20 or later, perform the Firmware Update again.

USB Driver Troubleshooting

Check the USB driver using Windows Device Manager:

With the **C-more** panel connected to the PC, on the PC, open **Control Panel--> System -->Hardware tab --> Device manager**. Next expand “Network adapters”. The **C-more** driver is named **C-more CM5** as shown below:

If the **C-more** programming software Communication Config dialog USB indicator is red, and the driver does not appear in Device Manager,

- 1) Unplug both end of the cable and replug them in.
- 1) If that does not establish communication, plug into a different USB port on the PC.
- 1) If there are any USB hubs or other devices being used, temporarily eliminate them to see if this solves the problem.
- 1) Reinstall the **C-more** HMI USB driver.

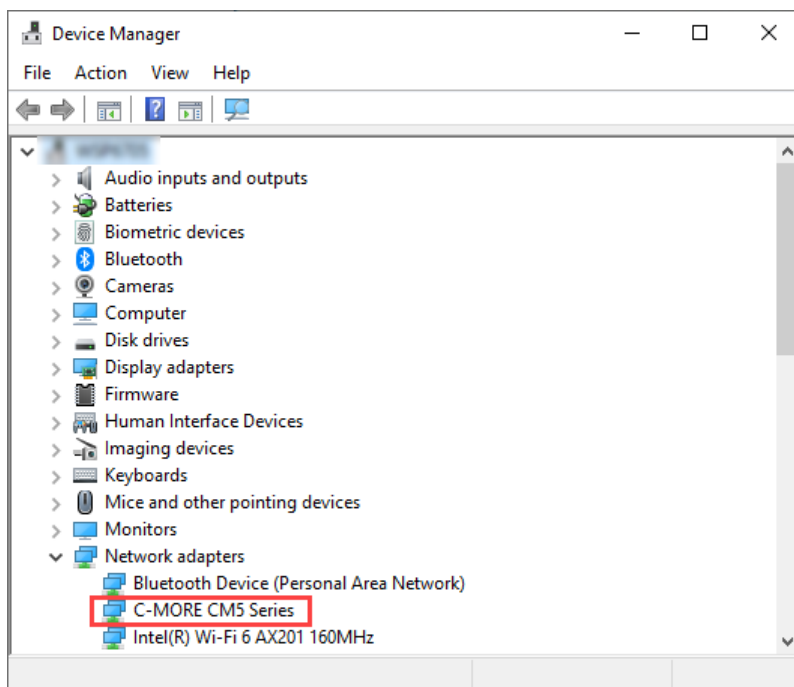

The **C-more** USB driver installation utility is bundled with the **C-more** software installation files. If you have a **C-more** software CD, the file is in the root, called CM5_USBDriver.exe.

- 1) If you downloaded the software, when you extracted the files, the CM5_USBDriver.exe was extracted to the location you chose. First, close the **C-more** software and disconnect the USB cable from the PC. Then, browse to CM5_USBDriver.exe and run it.
- 1) Plug the USB cable into the PC and the **C-more** panel.
- 1) The Found New Hardware Wizard will prompt you to search for the driver. Select “No not this time”, click Next. Select “Install the Software automatically (Recommended)” click **Next**. Click **Continue Anyway** in the Windows Logo warning popup. Click **Finish**.
- 1) Open the project in the **C-more** software. The Communication Config (and Transfer Project) USB indicator should be green.

No Communications between Panel and PC (Personal Computer)

There can also be a conflict with another Ethernet connection that may be using the same **IP Address**. You may want to check the setup both in the touch panel and also in your PC. As a starting point, it is best to start with an assigned IP Address and Subnet mask, mainly to eliminate IP addressing conflicts. Use the **C-more** programming software and open the **Panel Network** dialog box. Click on the **Ethernet Port** tab to display the dialog box used to set up the touch panel's **Ethernet** port.

Another cause of an **Ethernet** communications problem that may be encountered, is the touch panel doesn't show up in the node list, which can be caused by the PC having a firewall.

The figure below shows the **Panel Network** dialog box with the **Ethernet Port** tab opened. The **Save settings to Project** check box is checked and we are using the **Use the following IP Address** selection by checking its radio button. **The subnet (192.168.100.X) and the subnet mask (255.255.255.0) must be the same for both the panel and the PC.**

See the **C-more** programming software on-line help for additional details regarding the **Panel Network**.

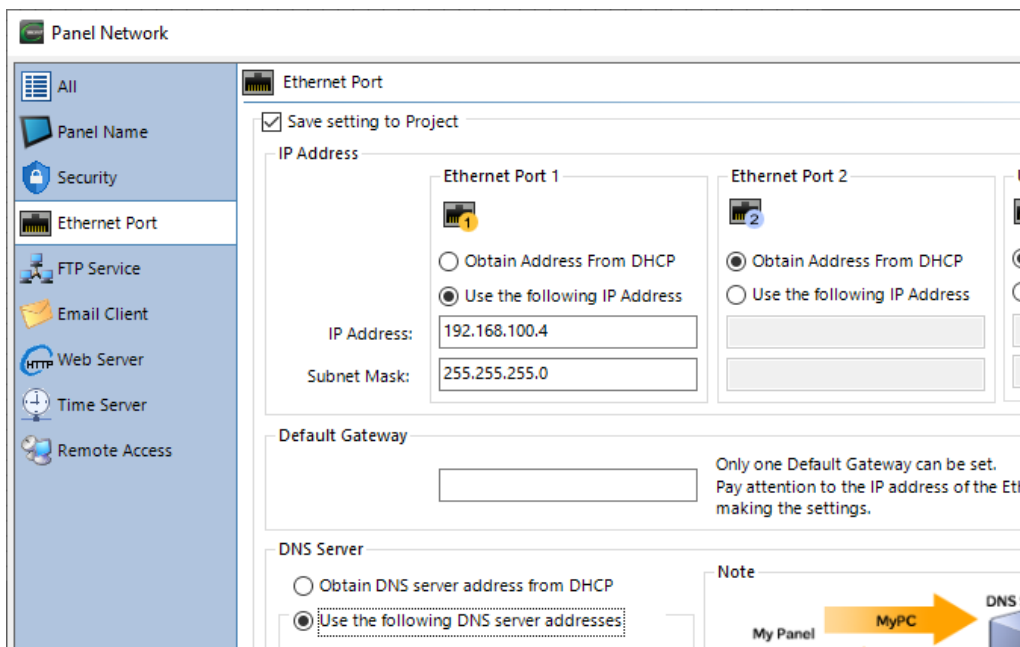

The IP Address assigned to the touch panel can also be checked or edited by using the system setup screens built into the touch panel. See Chapter 5: System Setup Screens for additional information.

No Communications between Panel and PC (Personal Computer) (cont'd)

The *C-more* software will then identify the USB connection with a green indicator.

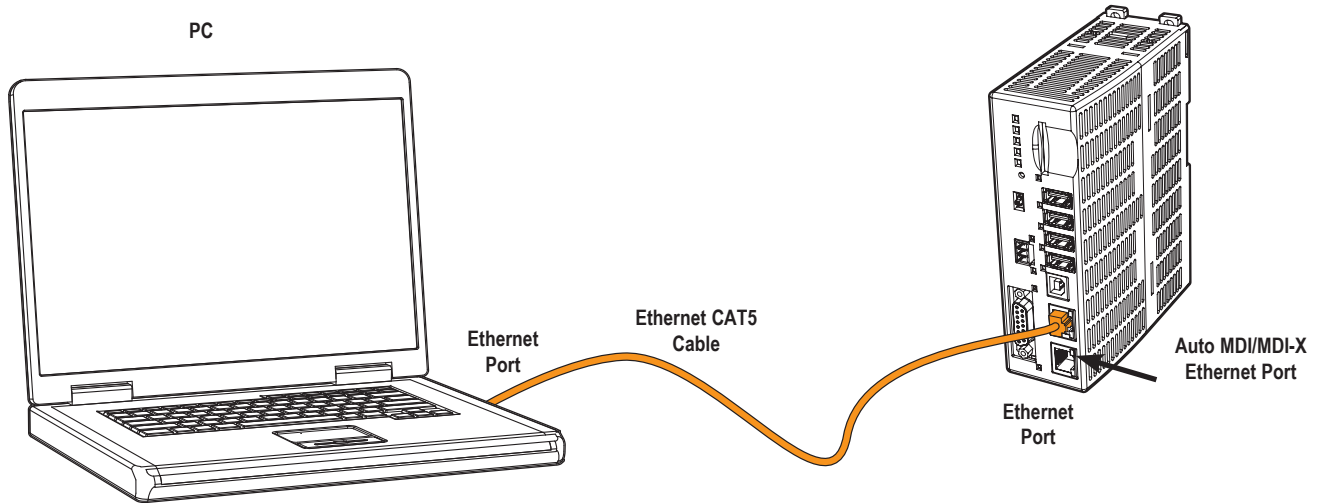

This Communication indicator appears on the Panel tab in the Navigation window and in the Project Transfer or Read from Panel windows.

No Communications between Panel and PC (Personal Computer) (cont'd)

The figure below shows a different example of the panel's System Setup Screens Ethernet Port dialog box for configuring the Ethernet port.

Network Settings			
	Ethernet Port 1	Ethernet Port 2	USB Ethernet Port
Obtain Address From DHCP :	<input type="radio"/>	<input type="radio"/>	Not Connected
Use the following IP Address :	<input checked="" type="radio"/>	<input checked="" type="radio"/>	
IP Address :	<input type="text" value="192.168.1.135"/>	<input type="text" value="10.11.250.10"/>	
Subnet Mask :	<input type="text" value="255.255.255.0"/>	<input type="text" value="255.255.255.0"/>	
Default Gateway :	<input type="text" value="192.168.1.1"/>		
<input type="radio"/> Obtain DNS Server Address from DHCP <input checked="" type="radio"/> Use the following DNS Server Address			
Preferred Address :	<input type="text" value="8.8.8.8"/>		
Alternate Address :	<input type="text" value="0.0.0.0"/>		
		<input type="button" value="OK"/>	<input type="button" value="Cancel"/>

No Communications between Panel and PC (Personal Computer) (cont'd)

Another option for accessing the **IP Address** assigned to the touch panel is to use the **C-more** Programming Software. Open the Navigation window's Panel tab and click on the **Browse** button under the **Communication** window at the bottom. This will open the **Ethernet Connection Setup** window. The **Online Link List** tab will show all of the connected panels. If none are shown, try clicking the **Browse Network** button to search for attached devices. Double click on the **Panel Name** you want to access and this will bring up the **Change IP Address** window. In this window changes can be made to the panel's name, IP address, subnet mask, and default gateway.

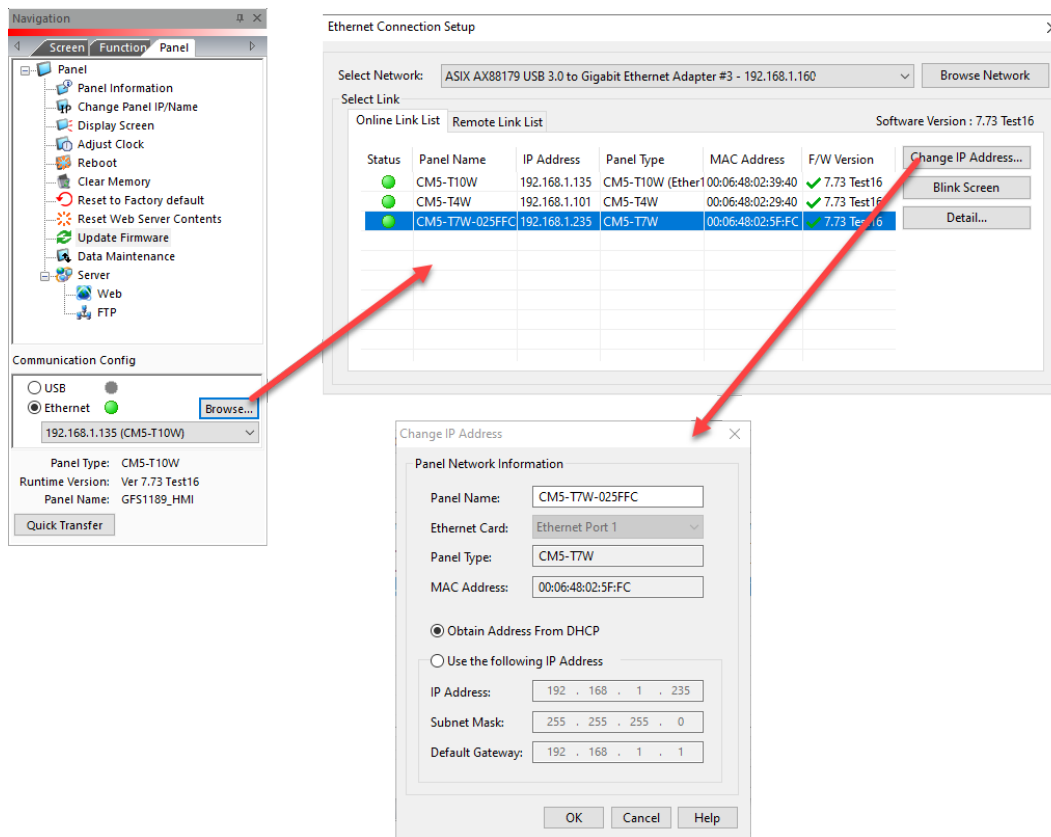

No Communications between Panel and PC (Personal Computer) (cont'd)

Check the **IP Address** setting of the PC by opening the Windows operating system's **Control Panel**.

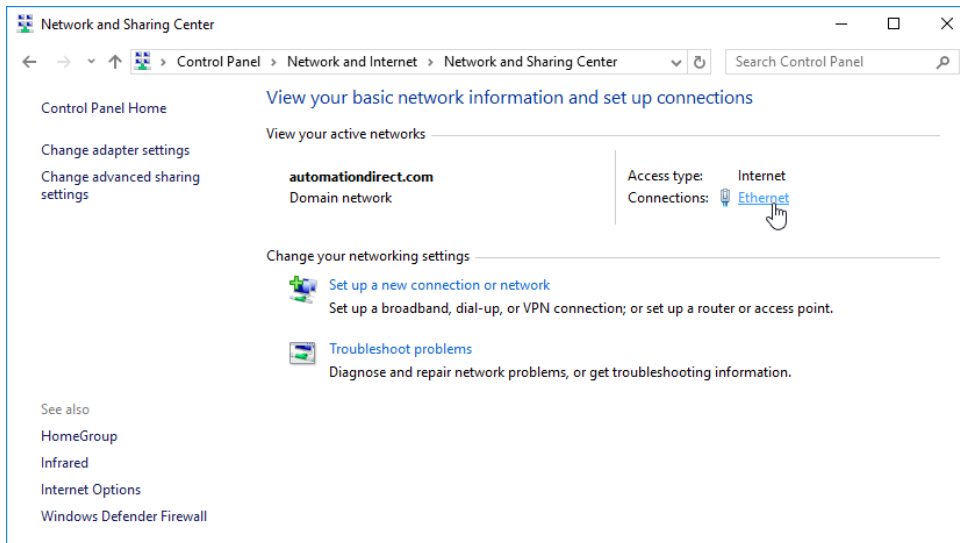

Select **Network and Internet** and then **Network and Sharing Center**. Click on **Ethernet** as shown below.

The Ethernet Status dialog will open. Select **Properties** and choose the appropriate **Internet Protocol** in the connections list. Select **Properties**. The **Internet Protocol Properties** window will open. Make sure the **Subnet Mask** is set the same for both the HMI and PC and also make sure that the **IP Addresses** do not conflict.

No Communications between Panel and PC (Personal Computer) (cont'd)

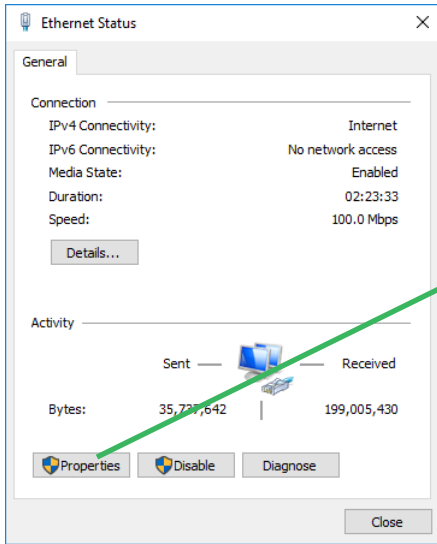

NOTE: If a DHCP Server is being used to obtain the IP Address for the PC, there are ways to identify the IP Address. For example, if using Windows 10, open a Command Prompt (Run > CMD) and type `IPCONFIG /ALL`. A list of all Ethernet assignments for the PC will be shown.

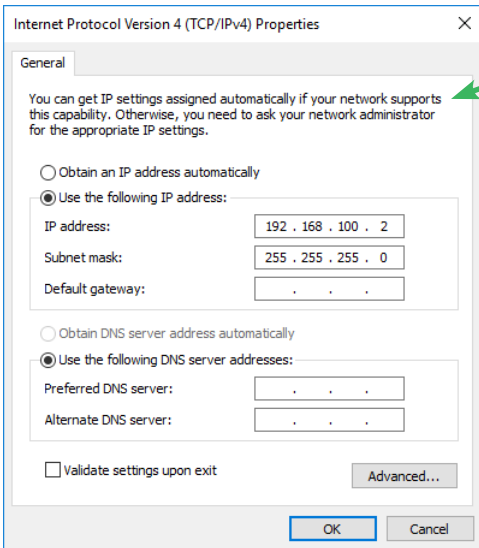
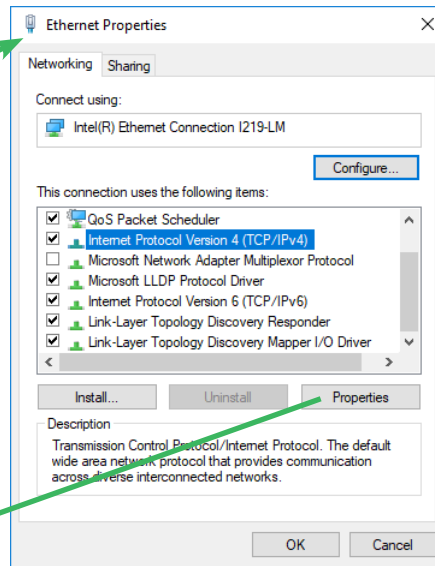

No Communications Between Panel and PC (Personal Computer) via USB

The **C-more** HMI is programmed using the **C-more** Programming Software, CM5-PGMSW. The developed project is transferred from the PC to the HMI by either a USB or an Ethernet connection between the two. (Ethernet available on full feature units only.)

If using USB, then a USB type AB programming cable, such as p/n USB-CBL-AB15, should be used to make a connection between the panel's USB Port, Type B and a USB port on the PC. The **C-more** Programming Software will install a USB driver on the PC during the software installation.

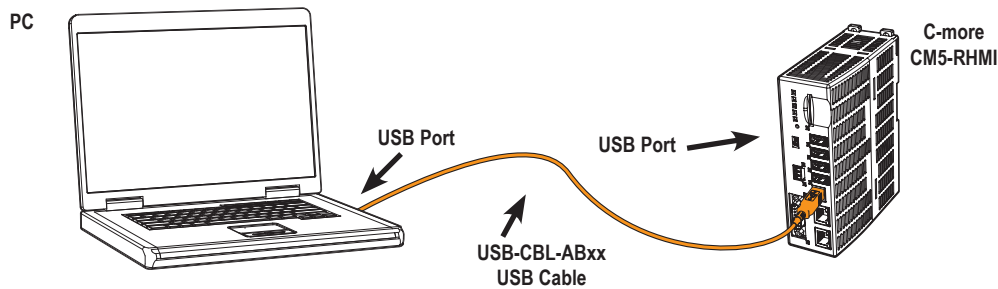

If the USB connection to the panel is recognized by the PC, you will hear the Windows device-recognized-sound when the powered panel is connected to the PC. The driver will appear in the Windows Device Manager under Network adapters as If the USB connection to the panel is recognized by the PC, you will hear the Windows device-recognized-sound when the powered panel is connected to the PC. The driver will appear in the Windows Device Manager under Network adapters as **C-more** CM5.

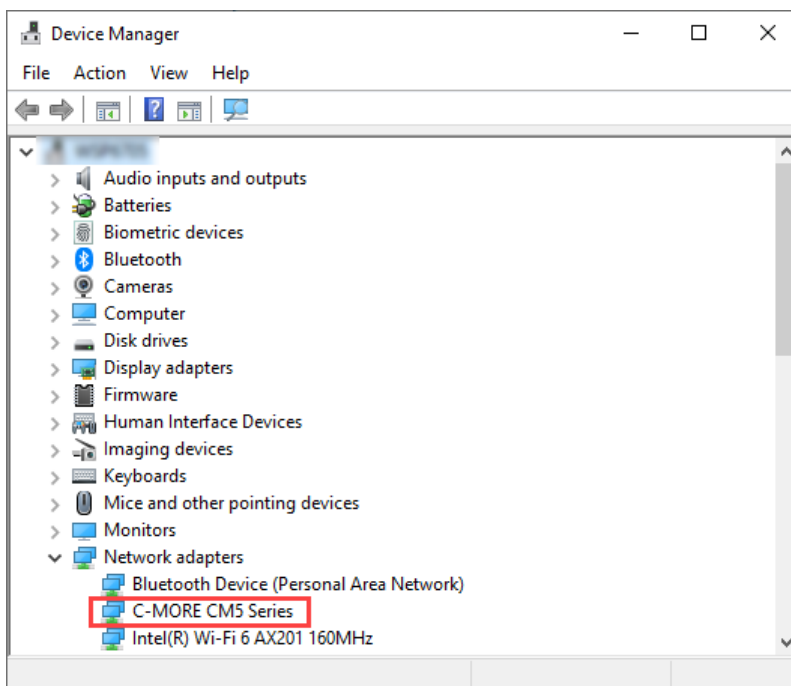

No Communications between Panel and PC (Personal Computer) via USB (cont'd)

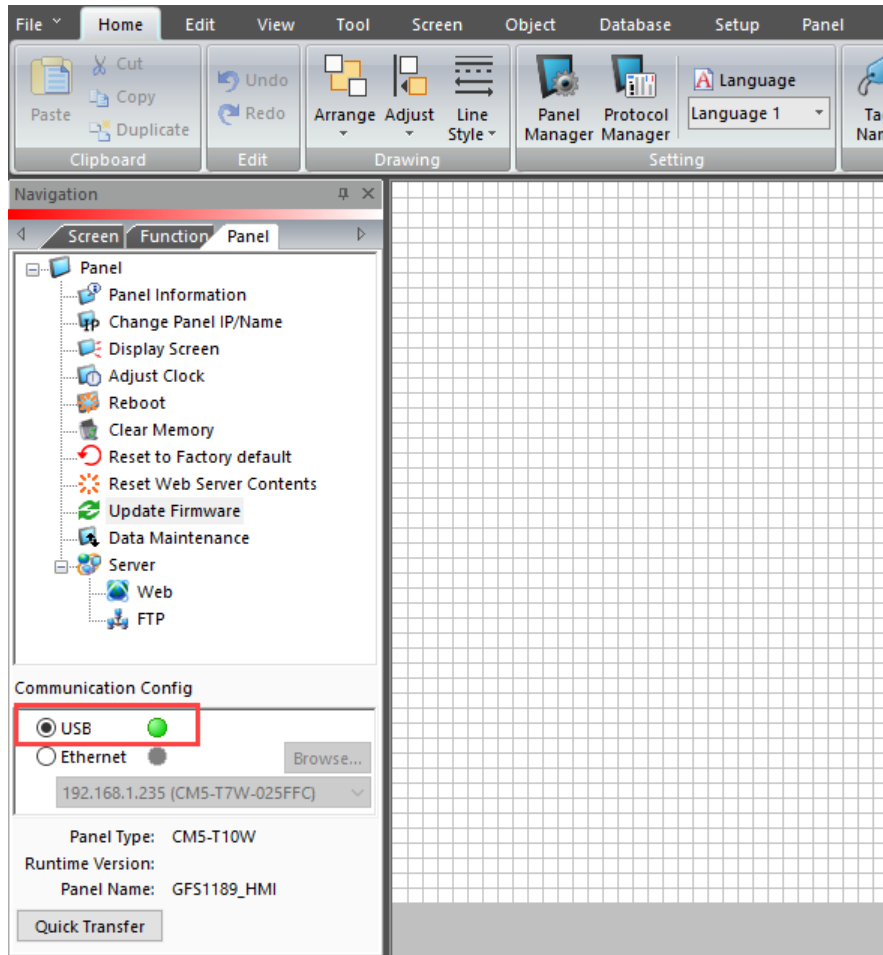

The **C-more** software will then identify the USB connection with a green indicator.

This Communication indicator appears on the Panel tab in the Navigation window and in the Project Transfer or Read from Panel windows.

No Communications Between Panel and PC (Personal Computer) via Ethernet

When using an **Ethernet** connection to communicate between the HMI and the PC and the communications does not seem to be working, the first area to check is the Ethernet status indicators located next to the **10/100 Base-T Ethernet Port** on the front of the CM5-RHMI. The **Link Status LED** must be displaying a steady or blinking green.

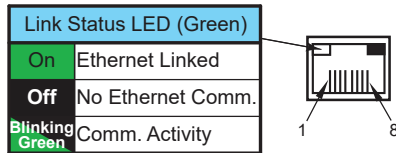

If using **Ethernet**, there are two basic ways to make the connection. You can use an **Ethernet** cable to make a direct connection between the HMI and PC or use an **Ethernet** cable from the HMI to a switch and then to the PC.

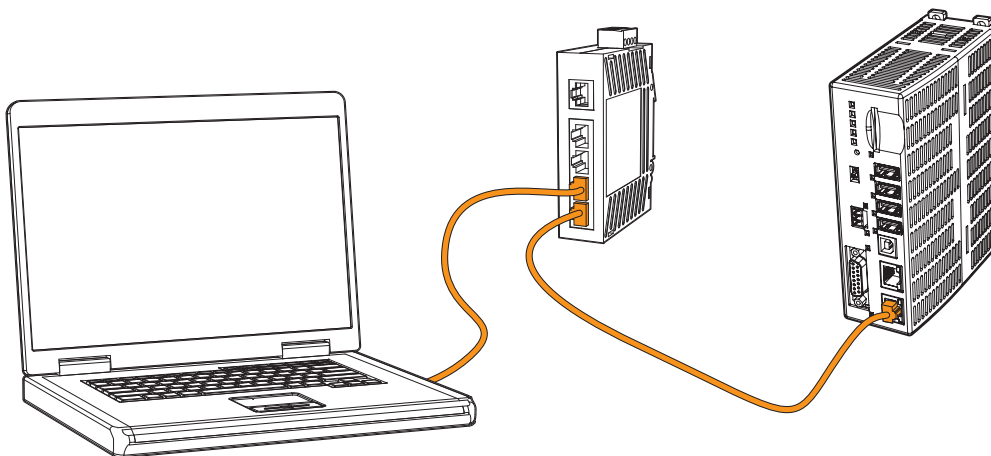

Use the **C-more** programming software to check the status of the **Ethernet** communications. From the **Navigation** window, select the **Panel** tab. At the bottom of the **Panel** tab is the **Communication Config** dialog box. Select the **Browse** button. If the connection is working the panel will be listed in the online link list. Select the panel and then select OK. If the **Ethernet** communications to the panel is working, then there should be a “green” indicator next to the **Ethernet** selection. There should also be an **IP Address** shown in the browse box below the **Ethernet** selection. If the **Ethernet** radio button is “red”, then you will need to check your **Ethernet** cables and connections or **Browse** for the panel.

No Communications between Panel and PLC

The communications between the **C-more** touch panel and designated PLC or controlling device can be accomplished by either a serial connection or by an **Ethernet** connection. The CM5-RHMI includes a 15-pin RS-232/422/485 port and at least one Ethernet port. The 10-inch through 22-inch panels include a 3-wire RS-485 connection.

- 1) If the touch panel and PLC are connected serially and the communications have seemed to stop working, then first check the **TxD** and **RxD** status indicators on the front of the CM5-RHMI at the connected port for activity.

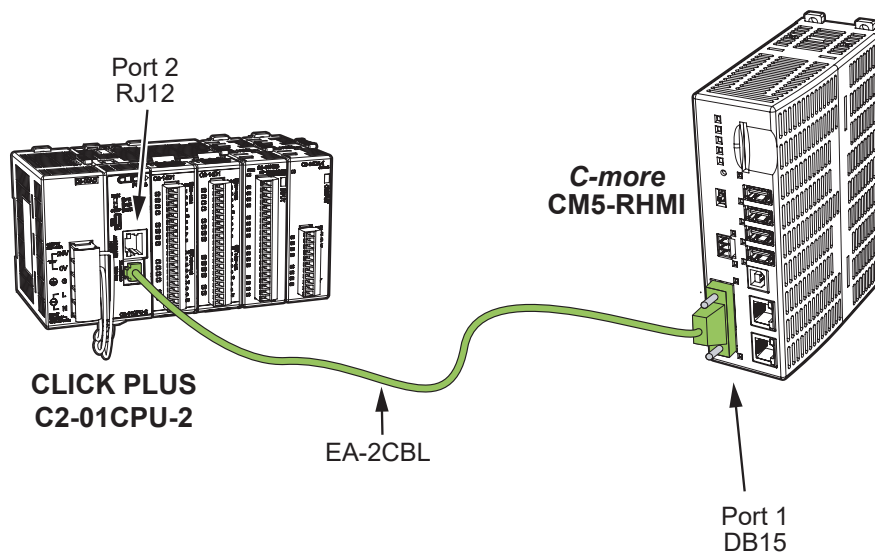

If there is no activity on one or both the TxD and RxD status indicators, then it should be suspected that either:

- *serial comm port settings are incorrect*
- *the cable is bad and needs to be replaced*
- *the serial port on the panel is defective*
- *the PLC serial port is bad*
- *No TxD also can indicated no tags being polled on device*

No Communications between Panel and PLC (cont'd)

The status indicators will show activity whether the serial communications is wired for RS-232 or RS-422/485.

Electrical noise, pulse generating wiring and/or improper grounding can also cause problems with communications. Refer to the **Electrical Noise Problems** section later in this chapter for additional help.

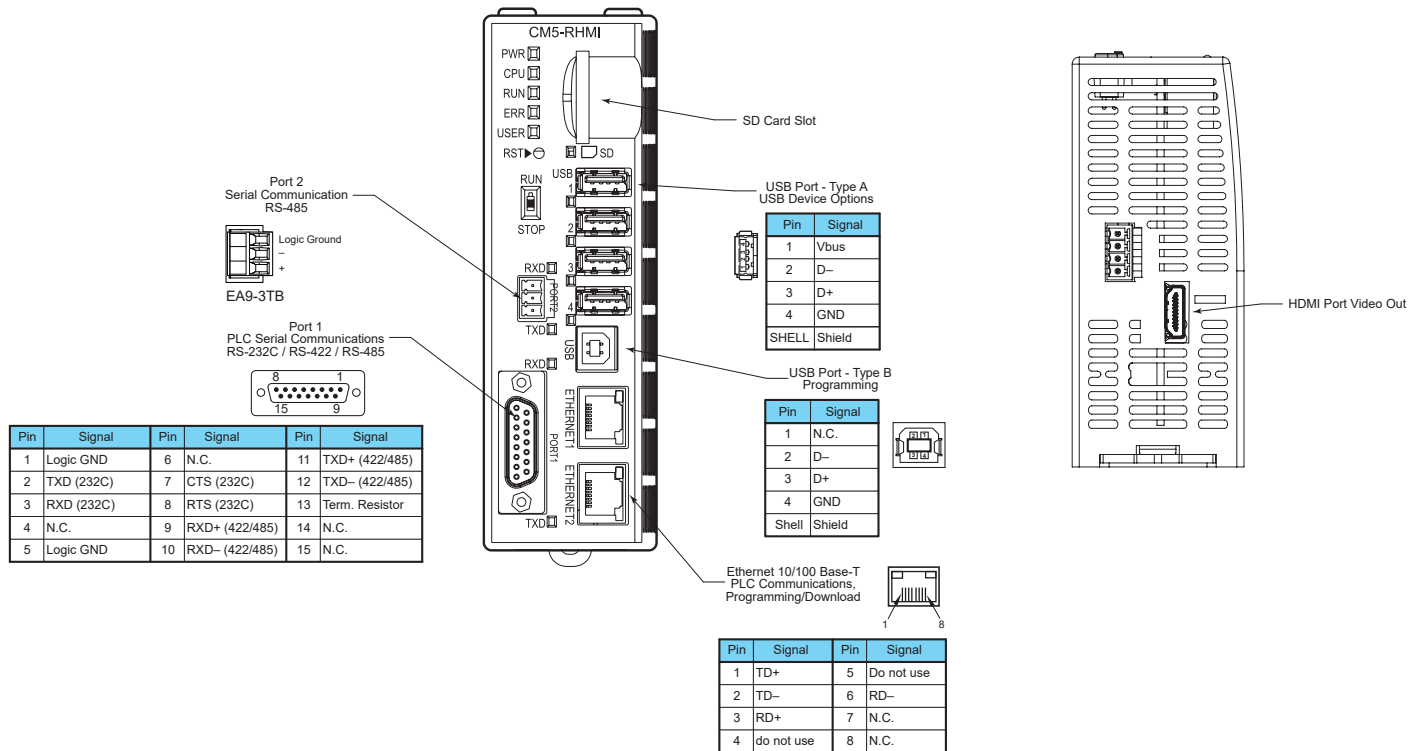

No Communications between Panel and PLC (cont'd)

The serial ports on the **C-more** HMI can be tested using the HMI's system setup screens. Access the **Main Menu** of the HMI's system setup screens, press the **Test Menu** button, then press the **Test Serial Port** button and select the appropriate port tab. You will need to fabricate a **Loop Back Connector** for the type of serial connection that is being used in your application, either RS-232 or RS-422/485, per the wiring diagrams shown below. Plug the loop back connector into the panel's 15-pin PLC serial communications port and then press the **Loop Back Test** button to run the test. See **Chapter 5: System Setup Screens** for additional information.

Loop back connector wiring diagrams:

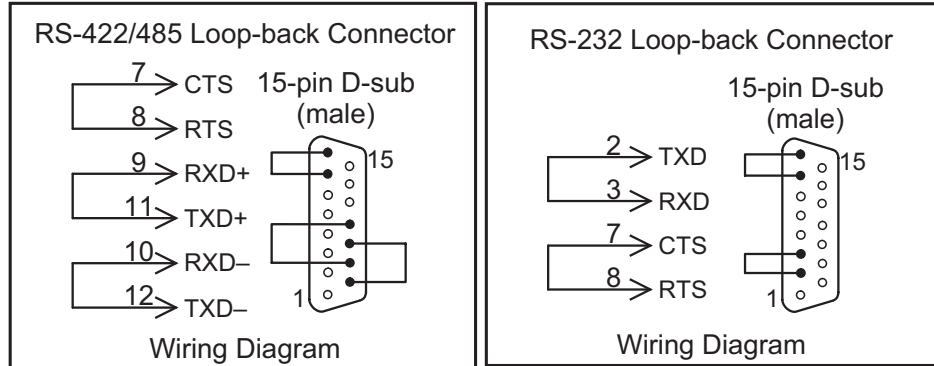

System setup screens **Test Comm. Port** dialog boxes:

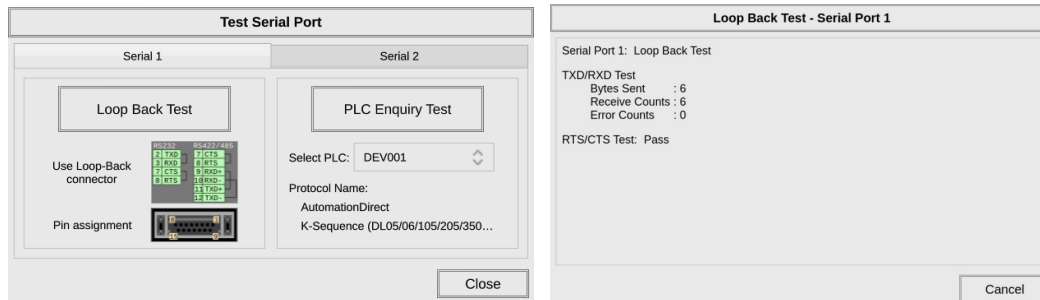

The **PLC Enquiry Test** can also be performed to determine if the **Ethernet** communication is working correctly between the panel and designated PLC.

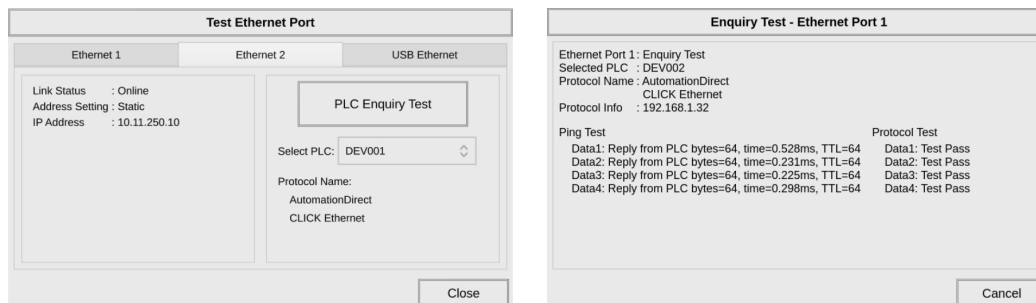

NOTE: The CM5-RHMI does not have a Serial 3 Port.

No Communications between Panel and PLC (cont'd)

If using an **Ethernet** connection between the HMI and the PLC, and there is a problem with the communications, the first area to check is the **Ethernet** status indicators located next to the **10/100 Base-T Ethernet Port** (shown below) on the HMI.

Link Status LED (Green)	
On	Ethernet Linked
Off	No Ethernet Comm.
Blinking Green	Comm. Activity

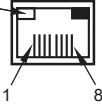
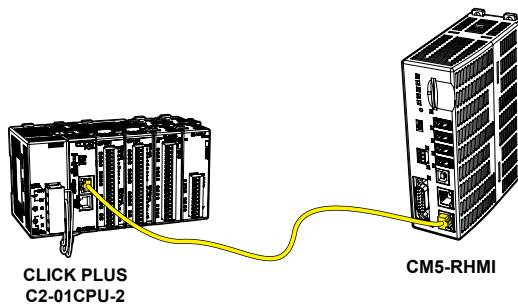
There are two basic ways to make the connection. You can connect directly from the HMI to the PLC or

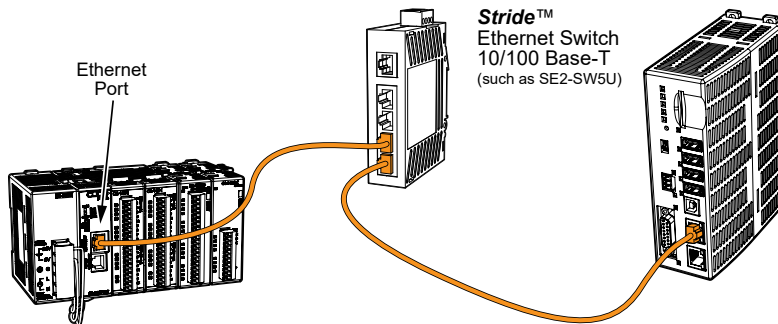

connect from the HMI to a switch that is also connected to the PLC.

Check the status indicators that may be included with the **Ethernet** communications module or device that is part of the PLC. Refer to the PLC's Ethernet user manual for further troubleshooting information.

No Communications Between Panel and PLC (cont'd)

The Ethernet port on the **C-more** touch panel can be tested by using the panel's system setup screens. Access the **Main Menu** of the panel's system setup screens, press the **Test Menu** button and then press the **Test Ethernet Port** button. Select the Ethernet tab in the **Test Ethernet Port** dialog box. Make sure the Ethernet port is connected to an Ethernet switch or other Ethernet communications device select a PLC from the drop down selection box, and then press the **PLC Enquiry** button to run the test. See **Chapter 5: System Setup Screens** for additional information.

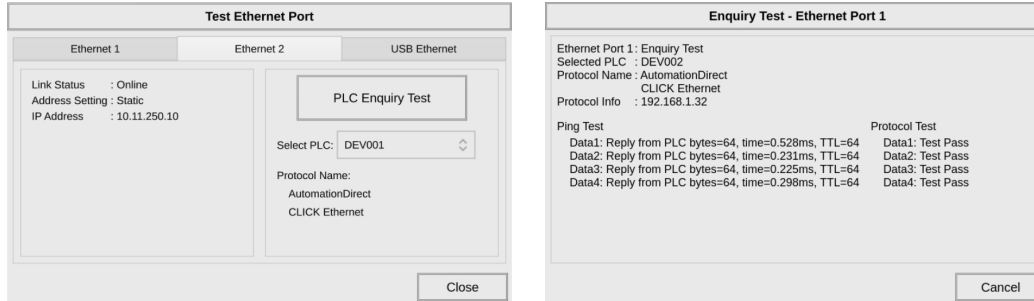

If a PC running the **C-more** programming software is connected to the **Ethernet** network that is also connected to both the touch panel and PLC, then certain functions in the software, such as the **Panel Information** window can be used to help troubleshoot problems with the touch panel's communications and operation. See the **C-more** programming software's on-line help for additional information.

IP Address in System Setup Screens Displays 0.0.0.0



NOTE: If entering an **IP Address** for the **C-more** HMI using the **System Setup Screens**, and the **IP Address** keeps displaying **0.0.0.0**, even after entering an **IP address**, the panel is not functionally connected to an active network. Either the cable, hub, or switch is bad. The entered **IP Address** is stored in the panel's memory but won't show up until a good connection is established. Keep in mind that if in the **C-more** programming software's **Panel Network** dialog box, under **Ethernet Port**, you have checked the **Save settings to Project** check box and have entered an **IP Address** of **0.0.0.0**, then anytime the project is transferred to the panel, the panel's **IP Address** will be overwritten with the entered address.

Difficulty Connecting to the Panel over the Internet (Web Server and Remote Access Features)

- 1) Refer to the software help file topics **Panel Network** and **Remote Access Setup** for information on configuring the Remote Access accounts, the Web Server Function and the panel IP Attributes.
- 2) In the Ethernet Port window, if DHCP is selected for assigning the IP address, verify the correct address of the panel. The IP address assigned by DHCP may change over time.
- 3) Note that the Web Server Function must be enabled in the Web Server window before the Remote Access Server Function can be accessed on the panel.
- 4) Verify that the correct TCP ports have been opened and forwarded on the router controlling access to the network where the **C-more** panel resides.
- 5) If two **C-more** HMIs are on a network behind a firewall and they have the same **Remote Access port number**, the router will use the first entry in the Port Forwarding setup that it encounters. The same **C-more** HMI will always come up even if the two HMIs have two different Web Server Port numbers.
- 6) When entering the URL in Internet Explorer to connect the **C-more** web server using a port number other than the default (80), be sure to use the full URL text including the prefix “http://”. The URL should be http://xxx.xxx.xxx.xxx:aaaaa where xxx.xxx.xxx.xxx is the IP address of the HMI and aaaaa is the port number configured in the Web Server window of the Panel Network setting.

PLC Protocol Error Codes

The **C-more** HMI includes built-in PLC communication protocol diagnostics that monitor the exchange of data between the panel and the PLC. The diagnostics look for the proper exchange of data, correct handshaking signals, addressing errors, incorrect data bytes, wrong packet format, etc. The diagnostics also monitor and report any of the errors that the designated PLC would normally generate if there is a problem with the PLC's communications. Each brand of PLC has its own unique set of diagnostic errors that are typically communicated over the PLC's communications port. The PLC generated errors are interpreted by the **C-more** software. See the PLC manufacturer's user manuals for additional details on the designated PLC's errors.

If a **C-more** communications error does occur, the error message will be displayed in the upper left of the **C-more** screen and the **Error Code** is recorded in the panel's error log. If a PLC error occurs, the PLC error code number will appear across the top of the screen and the PLC error message may not be included in some cases. The error log can be viewed using the system setup screens. See **Chapter 5: System Setup Screens** under the **Information** window to bring up the Error tab which includes a description of the logged data.

A detailed list and description of the various PLC protocol errors can be found in **Appendix A: PLC Protocol Error Codes**.

Error Codes for <i>Direct Logic</i> – K-Sequence		
Error Code	Error Message	Description
PLC-001	PLC Communication Timeout (for single PLC) %Device% PLC Communication Timeout (for multiple PLCs, such as RS-422/485)	A timeout occurred after sending a request to the PLC %Device%. %Device% indicates the device name, such as DEV001. Example error message for multiple PLCs: DEV001 PLC Communication Timeout
PLC-002	NAK received from PLC	A negative acknowledgement (NAK) control code has been generated during a read/write request.
PLC-004	STX is not found	A Start of Text (STX) control code was not found in the data packet received from the PLC.

HMI Runtime Errors

The **C-more** HMI includes built-in diagnostics that check for proper operation of the panel when it is running a project that has been transferred to its memory. Faults detected while the panel is running will produce a “Runtime” error. These errors are displayed in the upper left of the panel’s display and are also recorded in the panel’s error log. The error log can be viewed using the system setup screens. See **Chapter 5: System Setup Screens** under the **Information** window to bring up the **Error** tab which includes a description of the logged data.

A detailed list and description of the various HMI runtime errors can be found in **Appendix B: HMI Runtime Errors**.

No.	Error Log Code	Error Message Located at upper left of screen	Error Message Tag	Tag Error Code Value	System Screen Info > Error	Cause
Log Error						
1	RTE-001	Log Failed. Not enough Memory Space in %Device%	SYS ERR ERRORCODE	2001	MM/DD/YY HH/MM/SS Error Code RTE-001	The size of the destination memory is not large enough to store the data.
2	RTE-002	Log Failed. %Device% cannot be found	SYS ERR ERRORCODE	2002	MM/DD/YY HH/MM/SS Error Code RTE-002	No device available or the device is defective.

Panel Constantly Displays “Initializing” when Powering Up

If the HMI constantly displays a message reading “Initializing” while powering up, then check the following possible causes.

- 1) **C-more** supports USB 1.1 and 2.0 memory devices. Ensure that the USB device is 1.1 or 2.0 or backward compatible to support version 2.0
- 2) The project that is loaded into the panel’s internal SDRAM memory is corrupted. Either use the **C-more** programming software to clear the panel’s memory and re-transfer the project to the HMI or move the RUN /STOP switch to the STOP position. Select the **Memory** menu and use either **Clear Memory** or **Set to Factory Default** to clear the panel’s memory and re-transfer the project to the HMI. (see Chapter 5 - System Setup Screens)
- 3) An SD memory card has been plugged into an SD card slot and the SD card either has no project stored on it or the project is corrupted. Remove the SD memory card from the SD card slot and either load the project to the panel’s built-in Flash memory, re-format the SD card using the SD



NOTE: In the Error Log you may find the error RTE-500 - Check Sum Error, which is defined as “Memory in the panel has been corrupted by power loss, etc.” If this is the case, try cycling power to the panel, re-transfer the project to the panel, and re-transfer the firmware, etc. in sequential steps to try to correct the problem.

formatter available from SDcard.org, or try a different SD memory card.

Data Not Logging Problems

If the data log is missing entries, or a Runtime Error for the Log Errors as shown in **Appendix B: HMI Runtime Errors** is seen, then check the following possible causes.

- 1) Check that the memory devices that were selected for **Data Storage** under the **C-more** programming software’s **Main Menu - Setup** drop down - **Panel Manager** dialog box are plugged into their proper locations. Alarms, messages and screen captures can be independently selected to be saved to either a USB pen drive plugged into the USB Port - Type A, or an SD card plugged into the SD Card Slot.
- 2) Ensure that the SD card has been formatted with the SD formatter provided by SDcard.org.
- 3) The memory device could be bad. If possible, check it by plugging it into a PC that has the ability to access the memory device. Also, not all USB devices are compatible with the **C-more** HMIs. Try using the **AutomationDirect** USB Pen Drive, p/n USB-FLASH. Check **System Screen, Memory** for the presence of the USB device inserted.

Electrical Noise Problems

Noise is one of the most difficult problems to diagnose. Electrical noise can enter a system in many different ways which fall into one of two categories, conducted or radiated. It may be difficult to determine how the noise is entering the system, but the corrective actions for either of the types of noise problems are similar.

- Conducted noise is when the electrical interference is introduced into the system by way of an attached wire, panel connection, etc. It may enter through a power supply connection, the communication ground connection, or the chassis ground connection.
- Radiated noise is when the electrical interference is introduced into the system without a direct electrical connection, much in the same manner as radio waves.

While electrical noise cannot be eliminated, it can be reduced to a level that will not affect the system.

- **Most noise problems result from improper grounding of the system. A good earth ground can be the single most effective way to correct noise problems.** If a ground is not available, install a ground rod as close to the system as possible. Ensure all ground wires are single point grounds and are not daisy chained from one device to another. Ground metal enclosures around the system. A loose wire can act as a large antenna, introducing noise into the system. Therefore, tighten all connections in your system. Loose ground wires are more susceptible to noise than the other wires in your system. Review **Chapter 4: Installation & Wiring** if you have questions regarding how to ground the HMI.
- Electrical noise can enter the system through the power source for the HMI. Installing a properly wired isolation transformer (neutral grounded) for all AC sources can help the problem, but only if it is wired correctly. DC sources should be well-grounded good quality supplies.
- Never run communication cables or low-voltage power wiring close to high voltage wiring or pulse generating wiring that controls such devices as solenoids, servos, VFDs, etc.

Touch Screen Not Working

The CM5-RHMI is compatible with most HID compatible Resistive and pCap touchscreens.

Check with the manufacturer of the touch screen monitor about what touch screen drivers are supported by the touch screen. See page 8-9 for a list of compatible monitors and manufacturers.

BLANK
PAGE

REPLACEMENT PARTS





CHAPTER

9

In This Chapter...

Replacement Parts Overview	9-2
3-wire Communications Terminal Block – EA9-3TB.....	9-3
DC Panel Power Connector Replacement – C0-4TB.....	9-3

Replacement Parts Overview

Part Number		Description
EA9-3TB		<p>C-more pluggable terminal block, replacement, 3-pole. Package of 2. For use with 3-wire RS485 communications port on C-more EA9 series panels.</p>
C0-4TB		<p>CLICK terminal blocks, replacement, 4-pole. Package of 2. For use with CLICK PLCs and C-more CM5-RHMI.</p>

3-wire Communications Terminal Block – EA9-3TB

C-more CM5 series 3-wire communications terminal block replacement. One (1) terminal block is supplied with each HMI. Two (2) connectors are supplied when ordered as a replacement part.

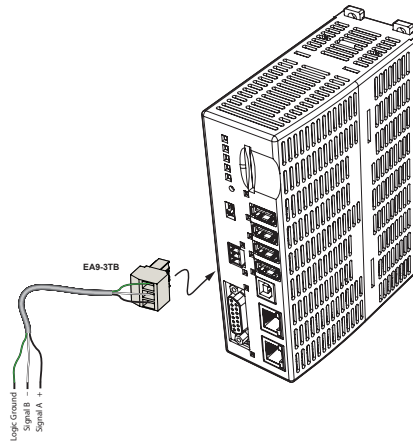

Tightening Torque	
Cable torque	Minimum 1.95 lb-in (0.22 Nm)



NOTE: Use 60/75 °C copper conductors only, 16-24 AWG

DC Power Connector Replacement – C0-4TB

CM5-RHMI 4-position DC power connector terminal block replacement. One (1) DC Power Connector is supplied with each HMI. Two (2) connectors are supplied when ordered as a replacement part.

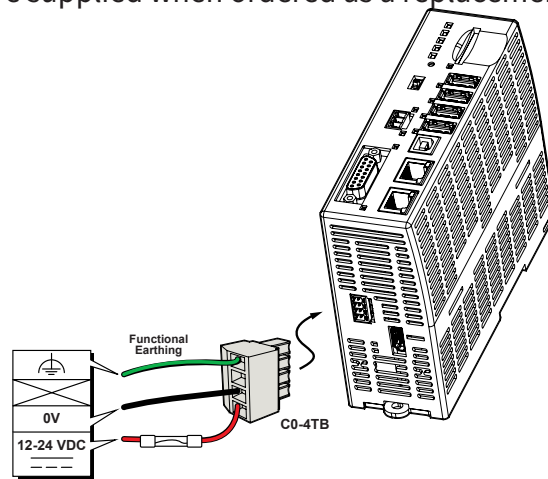

Tightening Torque	
Power supply cable torque	35.4 oz-in (20.25Nm)



NOTE: Use 60/75 °C copper conductors only, 16-24 AWG

BLANK
PAGE

PANEL AND PLC ERROR CODE TABLES



APPENDIX

A

In This Section...

Introduction.....	A-2
<i>C-more</i> Touch Panel Error Code Table	A-3
DirectLOGIC – Panel Error Code PLC-499 Explanation	A-5
DirectLOGIC Error Code PLC-499 Message Example.....	A-5
DirectLOGIC K-Sequence Protocol - PLC Error Code Table	A-5
DirectLOGIC DirectNET Protocol – PLC Error Codes.....	A-5
Modbus Protocols Error Code P499 Explanation	A-6
DirectLOGIC ECOM Protocol – PLC Error Codes	A-7
Productivity Error Code P499.....	A-7
AutomationDirect Do-More Error Codes	A-8
Allen-Bradley – Panel Error Code PLC-499 Explanation.....	A-9
Allen-Bradley Error Code PLC-499 Message Example.....	A-9
Allen-Bradley DF1 Protocol – PLC Error Code Tables.....	A-10
Allen-Bradley EtherNet/IP Protocol – Panel Error Code PLC-496, 497 and 498 Explanation	A-12
Allen-Bradley Error Code PLC-496, 497, 498 Message Example.....	A-12
Allen-Bradley – EtherNet/IP Protocol – PLC Error Code Tables ControlLogix, CompactLogix, & FlexLogix	A-13
Allen-Bradley – Micro800 Serial and EtherNet/IP Tag Based PLC Error Code Tables	A-17
Allen-Bradley – EtherNet/IP Protocol – PLC Error Code Tables.....	A-21
Generic EtherNet IP Protocol – PLC Error Codes	A-25
GE 90-30 – Panel Error Code PLC-499 Explanation	A-26
GE 90-30 Error Code PLC-499 Message Example	A-26
GE 90-30 SNPX Protocol – PLC Error Code Tables.....	A-27
Mitsubishi FX Protocol – PLC Error Codes	A-35
Omron – Panel Error Code PLC-499 Explanation	A-35
Omron Error Code PLC-499 Message Example	A-35
Omron Host Link Protocol – PLC Error Code Table.....	A-36
Omron FINS Protocol – PLC Error Code Table	A-37
Omron – Panel Error Code PLC-495 Explanation	A-39
Omron Error Code PLC-495 Message Example	A-39
Omron CS/CJ FINS Ethernet Protocol – PLC Error Code Table.....	A-40
Siemens – Panel Error Code P499 Explanation.....	A-41
Siemens Error Code PLC-499 Message Example.....	A-41
Siemens PPI Protocol – PLC Error Code Table.....	A-42
Siemens ISO over TCP Protocol – PLC Error Code Table	A-43

Introduction

The **C-more** family of touch panels is capable of communicating with a wide variety of Programmable Logic Controllers. **C-more** is capable of communicating over RS232, RS422 and RS485 serial networks as well as Ethernet networks. It communicates with all AutomationDirect PLCs utilizing various protocols. **C-more** also communicates with other brands of PLCs by their different protocols. For a complete list of PLCs and protocols, see **Step 9 – Connect Touch Panel to PLC in Chapter 1: Getting Started**.

As with any network communications, errors will occur. To make it more simple for the user to identify the cause of the possible error, we have provided an error code table for all of the possible errors that **C-more** can detect.

If a **C-more** communications error does occur, the error message will appear across the top of the screen. The **C-more** touch panel also monitors any errors that are generated by the various PLCs that are connected to it. If any of the PLC generated errors are detected, they are displayed across the top of the panel's display embedded as a hexadecimal value in error code P499's message. An explanation of how the specific PLC error is identified in the panel error code P499 is shown proceeding the specific manufacturer's PLC error tables. How the hexadecimal error code value is interrupted is slightly different between manufacturers, so it is important to check the explanation at the beginning of each



NOTE: These PLC error codes are provided by the manufacturer of the related PLC and are subject to change by the PLC manufacturer. Please refer to the manufacturers documentation for a more complete and up-to-date list of error codes.

manufacturer's tables.

All errors are also logged into the panel's **Error** log under the **Information** tab in the panel's **System Setup Screens** and are identified by the error code number. See **Chapter 5: System Setup Screens** for additional details. If you have difficulty determining the cause of the error, please refer to **Chapter 8: Troubleshooting** for some troubleshooting tips or contact our technical support



C-more Error Message

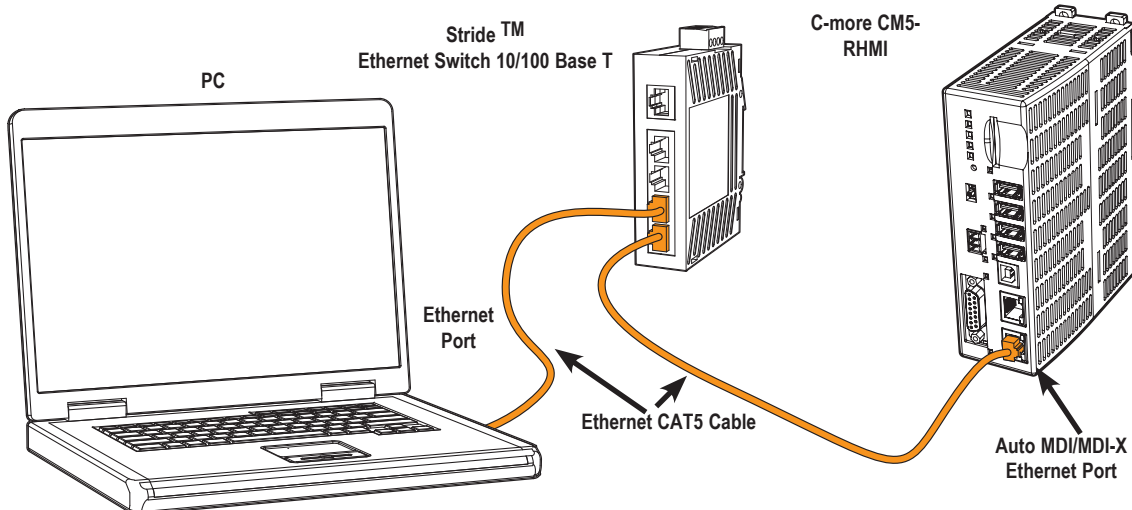

C-more Touch Panel Error Code Table

The following table includes all of the error codes and error messages that the panel will display if the listed cause is detected. All of these errors involve problems that could result with the panel communicating with the connected PLC. Be aware that not all of the panel errors are used with each type of PLC that can be connected to the panel.

C-more Touch Panel Error Code Table		
Error Code	Error Message	Cause
PLC-001	PLC Communication Timeout (for single PLC) %Device% PLC Communication Timeout (for multiple PLCs, such as RS-422/485)	A timeout occurred after sending a request to the PLC %Device%. %Device% indicates the device name, such as DEV001. Example error message for multiple PLCs: DEV001 PLC Communication Timeout.
PLC-002	NAK received from PLC	A negative acknowledgement (NAK) control code has been generated during a read/write request.
PLC-003	EOT received from PLC	An End of Transmission (EOT) control code is sent by the PLC in response to a Read/Write/SetBit request..
PLC-004	STX is not found	A Start of Text (STX) control code was not found in the data packet received from the PLC.
PLC-005	ETX or ETB is not found	Neither an End of Text (ETX) nor an End of Transmission Block (ETB) control code was found in the data packet received from the PLC.
PLC-006	LRC does not match	There was an incorrect Longitudinal Redundancy Check (LRC) control code in the communications packet received from the PLC. This is an indication that the data in the packet is corrupted.
PLC-007	CRC does not match	There was an incorrect Cyclic Redundancy Check (CRC) control code in the communications packet received from the PLC. This is an indication that the data in the packet is corrupted.
PLC-008	Address does not match	The address value returned in the data packet from the PLC is incorrect.
PLC-009	Different function code received from PLC	The function code returned in the data packet from the PLC is incorrect.
PLC-010	Data size does not match	There are an incorrect number of bytes found in the data packet returned from the PLC.
PLC-011	Invalid value in function code	There is an invalid value in the function code.
PLC-012	Invalid command sent to PLC	There was an invalid command sent to the PLC that wasn't recognized by the PLC.
PLC-013	ENQ received from PLC	If the data packet does not include a negative acknowledgement (NAK - 0x15 value) in the defined packet field, then an enquiry (ENQ) control code error will be displayed.
PLC-014	Transaction ID does not match	This error will be displayed if after checking the Transaction ID Bytes in the data packet, there is no match to what was requested.
PLC-015	%Device% No device found	A PLC device designated as %Device% could not be found.
PLC-016	Data byte communication error	0 byte of data is received
PLC-017	Out of address range	The touch panel requested a file number larger than 255.
PLC-018	Panel communication timeout	The server panel did not respond when using the Panel Pass Through.
PLC-019	Found in parity error by hardware	An error detected in the PLC memory.
PLC-020	Can't open serial port	Cannot open the Serial Port. If this error shows on the panel, it indicates a hardware problem.
PLC-021	PLC number does not match	The PLC number does not match the PLC number configured.
PLC-022	Can't reset DCB	Unable to reset the data communication bit.
PLC-023	Cable not connected properly	Communication cable incorrectly installed.
PLC-024	Cannot detect other devices on network	The panel is not communicating with other devices on the network.
PLC-025	Panel not in polling list	
PLC-026	PLC connection timeout	A timeout occurred after sending a request to the PLC.
PLC-027	Memory type incorrect	
PLC-028	PLC failed to respond	The PLC failed to respond after sending a request to the PLC.
PLC-029	MemVer ERR HMI x PLCy	When connected to a Do-more PLC the PLC memory version must match the C-more project PLC memory version. Make sure that the PLC project does not write into the memory version address.
PLC-495	Omron Ethernet Error	An error code specific to Omron Ethernet with a Value of XXXX has been returned from the PLC. See the explanation for error code PLC-495 proceeding the Omron CS/CJ FINS Ethernet error code tables.

C-more Touch Panel Error Code Table continued on the next page.

C-more Touch Panel Error Code Table (cont'd)

C-more Touch Panel Error Code Table		
Error Code	Error Message	Cause
PLC-496	Error code 0xaaaaaaaa returned from PLC	Allen-Bradley EtherNET/IP specific. Encapsulation Error. See the explanation for error code PLC-496 proceeding the Allen-Bradley EtherNet/IP error code tables.
PLC-497	Error code 0xaaaaaaaa returned from PLC	Allen-Bradley EtherNET/IP specific. CIP Error. See the explanation for error code PLC-497 proceeding the Allen-Bradley EtherNet/IP error code tables.
PLC-498	Error code 0xaaaaaaaa returned from PLC	Allen-Bradley EtherNET/IP specific. Service Packet Error. See the explanation for error code PLC-498 proceeding the Allen-Bradley EtherNet/IP error code tables.
PLC-499	Error code XXXX returned from PLC	An error code with a value of XXXX has been returned from the PLC. See the explanation for error code PLC-499 below for Direct LOGIC and proceeding each set of PLC error code tables that use this error code.
PLC-500	Cannot write to Serial Port	Data cannot write to the Serial port. Data was sent to the PLC via the Serial Port. If this error shows on the Panel, it indicates a Hardware Problem.
PLC-700	Not enough buffer memory	There was an error while allocating memory for the read buffer. When this error is displayed, a memory leak may have occurred.
PLC-701	Access to inaccessible PLC memory	Request to inaccessible memory from the HMI layer to the PLC protocol layer. This error is an indication that there is a problem in the HMI layer.
PLC-702	Cannot access by different function code	A Read/Write/SetBit request has been sent to an invalid memory area. This error is an indication that there is a problem in the HMI layer.
PLC-703	Write request to PLC Read Only Memory	A PLC Write request was made to the PLC's Read-Only memory area. This error is an indication that there is a problem in the HMI layer or the PLC protocol layer.
PLC-704	Bad device-access	No device (PLC) exists in the server panel or the device name does not match between the server and client when using the Panel Pass Through.
PLC-705	Protocol does not match	The protocol for the device does Not match between the server and client when using the panel pass through.

DirectLOGIC – Panel Error Code PLC-499 Explanation

The PLC-499 error code is used to show any errors that are generated by the connected PLC. The PLC-499 error message includes a four-digit hexadecimal value embedded in the message. This value can be looked up in the specific PLC’s error tables to determine the cause of the error. The possible PLC generated error codes for the **DirectLOGIC** communication protocol are represented by a hexadecimal value as shown in the following message example.

DirectLOGIC Error Code PLC-499 Message Example

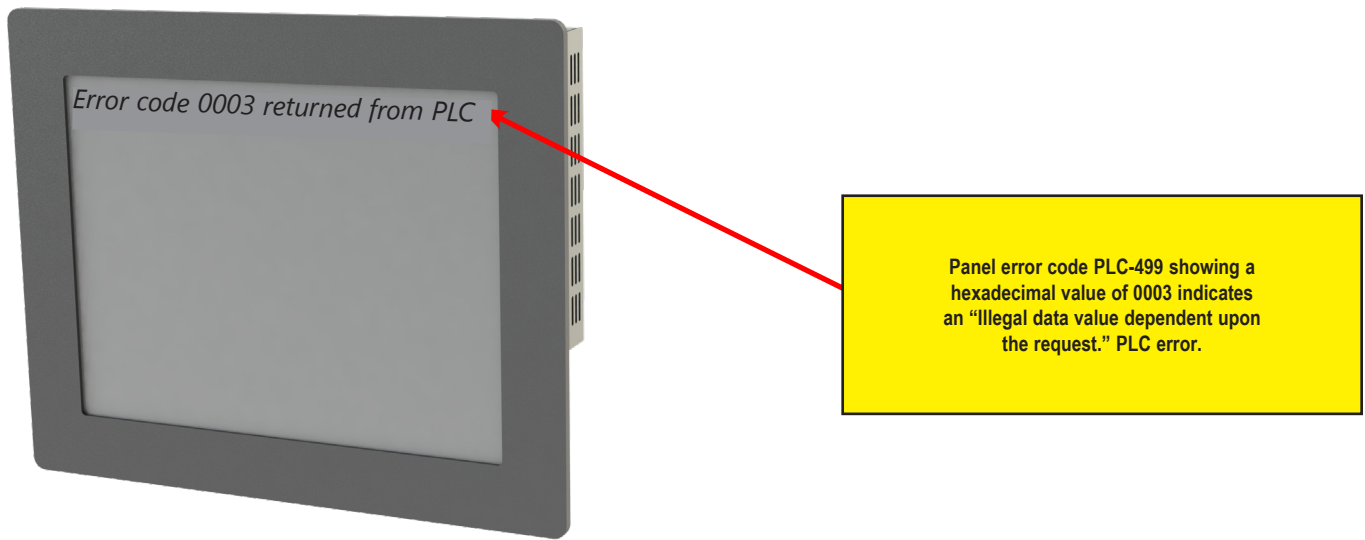

DirectLOGIC K-Sequence Protocol - PLC Error Code Table

The following table lists the errors that can be generated by the DirectLOGIC PLC when using the K-Sequence protocol.

PLC Error Codes for <i>DirectLOGIC</i> – K-Sequence	
Panel Error Code PLC-499 Hex Value	Description
01F8	Error setting value.
020D	Error in key mode - Set switch on PLC CPU to “Term”
021C	Password protected.



NOTE: The following errors can be generated from the designated PLC, are monitored by the C-more touch panel, and displayed on the touch panel’s screen as a hexadecimal value in panel error code PLC-499 message, if active. Please refer to the PLC manufacturer’s documentation for additional information.

DirectLOGIC DirectNET Protocol – PLC Error Codes

Only errors as listed in the Touch Panel Error Code Table shown on page A-3 can occur when using the **DirectLOGIC** DirectNET protocol, there are no PLC generated errors.

Modbus Protocols Error Code P499 Explanation

The following table lists the errors that can be generated by the Modbus protocols:

AutomationDirect CLICK

AutomationDirect DirectLOGIC - Modbus (Koyo)

Modicon Modbus RTU



NOTE: The following errors can be generated from the designated PLC, are monitored by the C-more touch panel, and displayed on the touch panel's screen as a hexadecimal value in panel error code PLC-499 message, if active. Please refer to the PLC manufacturer's documentation for additional information.

Entivity Modbus RTU

PLC Error Codes for Modbus		
Panel Error Code PLC-499 Hex Value	Name	Meaning
0x0001	ILLEGAL FUNCTION	The function code received in the query is not an allowable action for the server (or slave). This may be because the function code is only applicable to newer devices and was not implemented in the unit selected. It could also indicate that the server (or slave) is in the wrong state to process a request of this type, for example because it is unconfigured and is being asked to return registered values.
0x0002	ILLEGAL DATA ADDRESS	The data address received in the query is not an allowable address for the server (or slave). More specifically, the combination of reference number and transfer length is invalid. For a controller with 100 registers, the PDU addresses the first register as 0, and the last one as 99. If a request is submitted with a starting register address of 96 and a quantity of registers of 4, then the request will successfully operate (address-wise at least) on registers 96, 97, 98, 99. If a request is submitted with a starting register of 96 and a quantity of registers of 5, then the request will fail with Exception code 0x02 "Illegal Data Address" since it attempts to operate on registers 96, 97, 98, 99 and 100, and there is no register with address 100.
0x0003	ILLEGAL DATA VALUE	A value contained in the query data field is not an allowable value for server (or slave). This indicates a fault in the structure of the remainder of a complex request, such as that the implied length is incorrect. It specifically does NOT mean that a data item submitted for storage in a register has a value outside the expectation of the application program, since the Modbus protocol is unaware of the significance of any particular value of any particular register.
0x0004	SLAVE DEVICE FAILURE	An unrecoverable error occurred while the server (or slave) was attempting to perform the requested action.

DirectLOGIC ECOM Protocol – PLC Error Codes

Only errors as listed in the Touch Panel Error Code Table shown previously in this Appendix can occur when using the DirectLOGIC ECOM protocol, there are no PLC generated errors

Productivity Error Code P499



NOTE: The following errors can be generated from the designated PLC, are monitored by the C-more touch panel, and displayed on the touch panel's screen as a hexadecimal value in panel error code PLC-499 message, if active. Please refer to the PLC manufacturer's documentation for additional information.

PLC Error Codes for Productivity	
Panel Error Code PLC-499 Hex Value	Meaning
0x0001	The function code received in the query is not an allowable action for the server (or slave). This may be because the function code is only applicable to newer devices and was not implemented in the unit selected. It could also indicate that the server (or slave) is in the wrong state to process a request of this type, for example because it is unconfigured and is being asked to return registered values.
0x0002	Address out of range. Check to make sure that the C-more tag and System ID match the Productivity Programming Software Tag Name and System ID. The project file in the Productivity system and the imported CSV into C-more must be in sync with each other.
0x0003	A value contained in the query data field is not an allowable value for the server (or slave). This indicates a fault in the structure of the remainder of a complex request, such as that the implied length is incorrect. It specifically does NOT mean that a data item submitted for storage in a register has a value outside the expectation of the application program, since the Modbus protocol is unaware of the significance of any particular value of any particular register.
0x0004	An unrecoverable error occurred while the server (or slave) was attempting to perform the requested action.

AutomationDirect Do-More Error Codes

PLC Error Codes for Do-More		
Error Code	Description	Resolution
0x01	Unknown Command	Should only occur if message has been corrupted or protocol version is mismatched. Check versions and update appropriately. If versions are correct, check cabling, routing and switches for bad packets.
0x02	Out of Sessions	Too many devices connected to the CPU. Reduce number of devices connected.
0x03	Illegal Operation	Occurs when permission level is not sufficient for the operation performed by the panel. Increase the permission level to correct the problem.
0x04	Invalid Session	Session number does not match for sending device. Re-establish connection by power cycling or sending updated project.
0x05	Out of Range	Invalid address exists. Ensure that address range is expanded and load configuration to the CPU.
0x06	Invalid Argument	Occurs when message cannot be parsed correctly. Could occur from noise or faulty wiring.
0x07	Program Update Active	Wait until program update is complete.
0x08	No Token	Occurs when client attempts to update the project without first acquiring the program update token.
0x09	Program Update Inhibited	Occurs when client attempts to update the project while ST21 is true. This allows the customer to programmatically prevent the project from being updated.
0x0A	System Configuration Update Active	Wait until System Configuration update is complete to continue communications.
0x0B	Invalid Mode	Ensure that the switch on the CPU is in Term mode.
0x0C	Mode Change Active	Occurs when a PLC mode change is attempted while a mode change is in progress. In some cases it takes several scans for a mode change.
0x0D	Mode Locked	Occurs when mode change is attempted and keyswitch is not in Term.
0x0E	Invalid Password	Enter Do-more password in Password field of C-more Protocol Manager for this device.
0x0F	Resource Locked	Occurs when trying to update a tag that is forced. Force must be removed in order to update the tag.
0x10	Doc Update Active	Occurs when someone attempts to access the documentation file while it is being written back to ROM.
0x11	Invalid Driver	Occurs when attempting to read driver data from a driver that doesn't exist.
0x12	Invalid Driver Data	Occurs when attempting to read a driver data type that isn't valid.
0x13	Shared RAM write failed	Occurs when attempting to read or write to a module's shared RAM and it fails. Usually occurs when the module has gone bad.

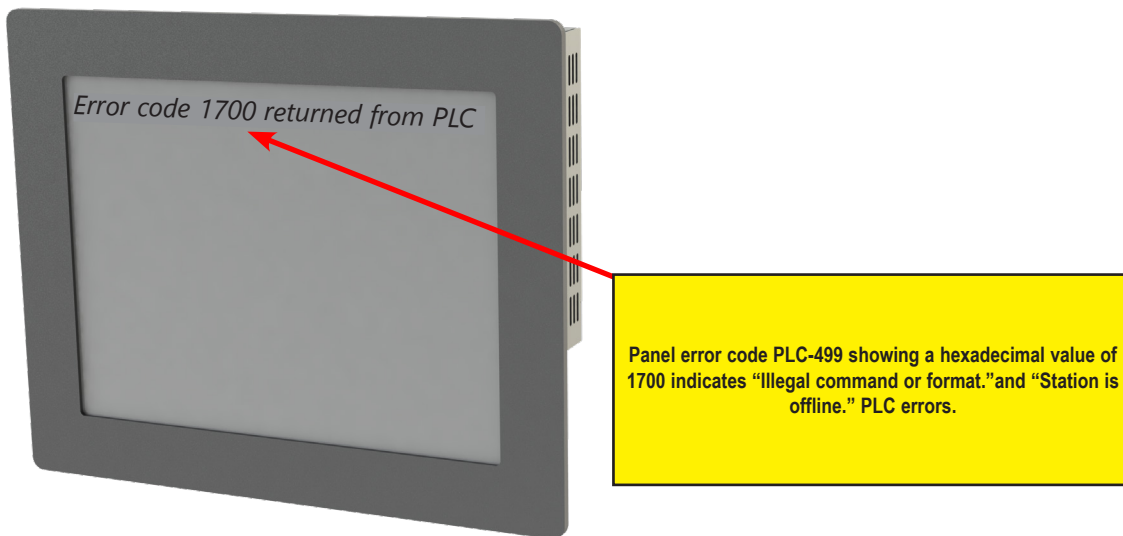

Allen-Bradley – Panel Error Code PLC-499 Explanation

The PLC-499 error code is used to show any errors that are generated by the connected PLC. The PLC-499 error message includes a four-digit hexadecimal value embedded in the message. This value can be looked up in the specific PLC’s error tables to determine the cause of the error. The possible PLC generated error codes for the Allen-Bradley DF1 communication protocols are represented by a hexadecimal value as shown in the following diagram. Please note that the error code is broken down into three sections. It is possible for more than one type of PLC error to be displayed in this value.

Allen-Bradley Error Code PLC-499 Message Example

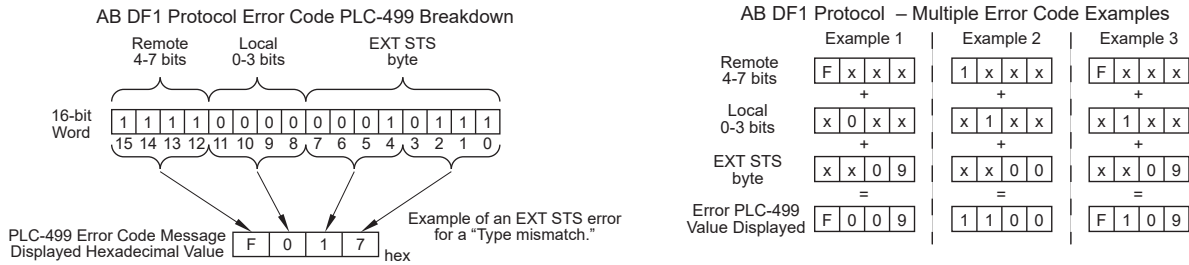

Allen-Bradley DF1 Protocol – PLC Error Code Tables

The following PLC error code tables cover possible errors that are detected by the panel from Allen-Bradley PLCs using the DF1 protocol. DF1 includes full and half duplex communications for the MicroLogix 1000, 1100, 1200, 1400, 1500, SLC 5/03, /04, /05, ControlLogix, CompactLogix and FlexLogix, and full duplex communications for the PLC5.



NOTE: The following errors can be generated from the designated PLC, are monitored by the C-more touch panel, and displayed on the touch panel's screen as a hexadecimal value in panel error code PLC-499 message, if active. Please refer to the PLC manufacturer's documentation for additional information.

PLC Errors for Allen-Bradley DF1 Protocol, Local STS Errors (0-3 bits)	
Panel Error Code PLC-499 Hex Value	Description
0x0	Success; no error.
0x1	DST node is out of buffer space.
0x2	Cannot guarantee delivery; link layer. (The remote node specified does not ACK command.)
0x3	Duplicate token holder detected.
0x4	Local port is disconnected.
0x5	Application layer timed out waiting for response.
0x6	Duplicate node detected.
0x7	Station is offline.
0x8	Hardware fault.

PLC Errors for Allen-Bradley DF1 Protocol, Remote STS Errors (4-7 bits)	
Panel Error Code PLC-499 Hex Value	Description
0x0	Success; no error.
0x10	Illegal command or format.
0x20	Host has a problem and will not communicate.
0x30	Remote node host is missing, disconnected, or shut down.
0x40	Host could not complete function due to hardware fault.
0x50	Addressing problem or memory protect rungs.
0x60	Function not allowed due to command protection selection.
0x70	Processor is in Program Mode.
0x80	Compatibility mode file missing or communication zone problem.
0x90	Remote node cannot buffer command.
0xA0	Wait ACK (1775 KA buffer full).
0xB0	Remote node problem due to download.
0xC0	Wait ACK (1775 KA buffer full).
0xD0	not used
0xE0	not used
0xF0	Error code in the EXT STS byte. See the error code table on the next page.

(PLC generated error codes for the Allen-Bradley DF1 protocol continued on the next page.)

Allen-Bradley DF1 Protocol – PLC Error Code Tables (cont'd)

PLC Errors for Allen-Bradley DF1 Protocol, EXT STS Command Code for F0 Command	
Panel Error Code PLC-499 Hex Value	Description
0x0	not used
0x1	A field has an illegal value.
0x2	Fewer levels specified in address than minimum for any address.
0x3	More levels specified in address than system supports.
0x4	Symbol not found.
0x5	Symbol is of improper format.
0x6	Address does not point to something usable.
0x7	File is wrong size.
0x8	Cannot complete request; situation has changed since start of the command.
0x9	Data or file size is too large.
0xA	Transaction size plus word address is too large.
0xB	Access denied; improper privilege.
0xC	Condition cannot be generated; resource is not available.
0xD	Condition already exists; resource is readily available.
0xE	Command cannot be executed.
0xF	Histogram overflow.
0x10	No access.
0x11	Illegal data type.
0x12	Invalid parameter or invalid data.
0x13	Address reference exists to deleted area.
0x14	Command execution failure for unknown reason; possible PLC 3 histogram overflow.
0x15	Data conversion error.
0x16	Scanner not able to communicate with 1771 rack adapter.
0x17	Type mismatch.
0x18	1771 module response was not valid.
0x19	Duplicated label.
0x22	Remote rack fault.
0x23	Timeout.
0x24	Unknown error.
0x1A	File is open; another node owns it.
0x1B	Another node is the program owner.
0x1C	Disk File is write protected or otherwise unavailable
0x1D	Disk File is being used by another application. Update not performed (offline only).
0x1E	Data table element protection violation.
0x1F	Temporary internal problem.

Allen-Bradley EtherNet/IP Protocol – Panel Error Code PLC-496, 497 and 498 Explanation

The PLC-496, PLC-497, and PLC-498 error codes are used to show any errors that are generated by the connected PLC. These error messages include an eight-digit hexadecimal value displayed embedded in the message. This value can be looked up in the specific PLC's error tables to determine the cause of the error. The possible PLC generated error codes for the Allen-Bradley EtherNet/IP communication protocol is represented by a hexadecimal value as shown in the following message example.

Allen-Bradley Error Code PLC-496, 497, 498 Message Example

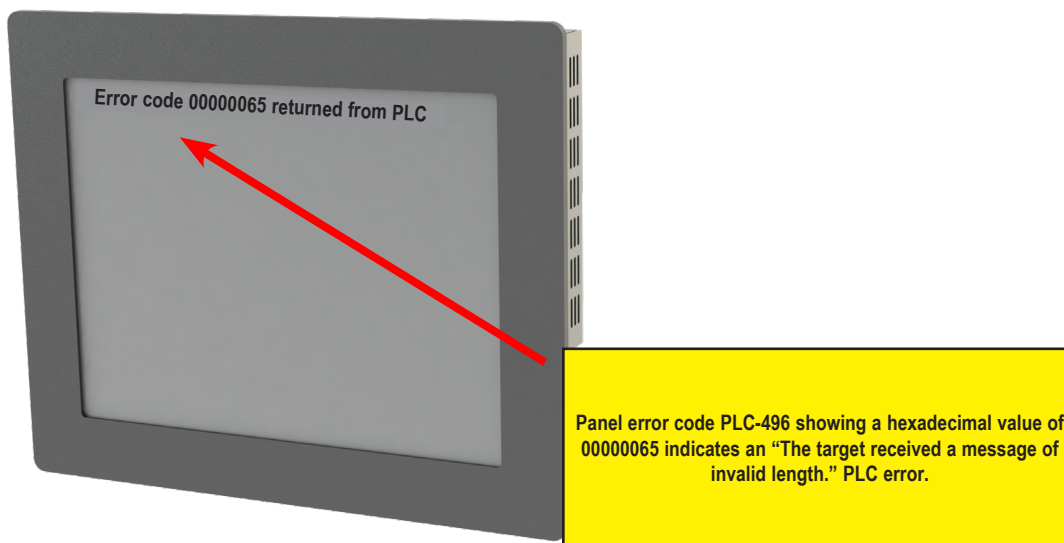

Allen-Bradley – EtherNet/IP Protocol – PLC Error Code Tables

ControlLogix, CompactLogix, & FlexLogix

The following PLC error code tables cover possible errors that are detected by the panel from Allen-Bradley PLCs using the EtherNet/IP protocol. This includes all ControlLogix, CompactLogix and FlexLogix PLCs.



NOTE: The following errors can be generated from the designated PLC, are monitored by the C-more touch panel, and displayed on the touch panel's screen as a hexadecimal value in panel error code PLC-499 message, if active. Please refer to the PLC manufacturer's documentation for additional information.

PLC Errors for Allen-Bradley EtherNet/IP Protocol – Encapsulation Errors (Error code 0xaaaaaa returned from the PLC.)	
Panel Error Code PLC-496 Hex Value	Description
0x00000001	The sender issued an invalid or unsupported encapsulation command.
0x00000002	Insufficient memory resources in the receiver to handle the command. You can get this error if the 1761-NET-ENI cannot connect to the PLC serially.
0x00000003	Poorly formed or incorrect data in the data portion of the encapsulation message.
0x00000004 - 0x00000063	Reserved for legacy (Rockwell Automation).
0x00000064	An originator used an invalid session handle when sending an encapsulation message to the target.
0x00000065	The target received a message of invalid length.
0x00000066 - 0x00000068	Reserved for legacy (Rockwell Automation).
0x00000069	Unsupported encapsulation protocol revision.
0x0000006a - 0x0000ffff	Reserved for future expansion.

PLC Errors for Allen-Bradley EtherNet/IP Protocol – CIP Errors (Error code 0xaaaaaa returned from the PLC.)	
Panel Error Code PLC-497 Hex Value	Description
0x010100	Connection Manager: Connection in Use or Duplicate Forward Open.
0x010103	Connection Manager: Transport Class and Trigger combination not supported.
0x010106	Connection Manager: Ownership Conflict.
0x010107	Connection Manager: Connection not found at target application.
0x010108	Connection Manager: Invalid connection type (problem with type or priority).
0x010109	Connection Manager: Invalid connection size.
0x010110	Connection Manager: Device not configured.
0x010111	Connection Manager: RPI not supported. Could also be problem with inactivity timeout.
0x010113	Connection Manager: Connection Manager cannot support any more connections.
0x010114	Connection Manager: Either the vendor ID or the Product Code in the key segment did not match the device.
0x010115	Connection Manager: Product Type in the key segment did not match the device.
0x010116	Connection Manager: Major or minor revision information in the key segment did not match the device.
0x010117	Connection Manager: Invalid connection point.
0x010118	Connection Manager: Invalid configuration format.
0x010119	Connection Manager: Connection request fails since there is no controlling connection currently open.
0x01011a	Connection Manager: Target application cannot support any more connections.
0x01011b	Connection Manager: RPI is smaller than the Production Inhibit Time.
0x010203	Connection Manager: Connection cannot be closed since the connection has timed out.

(PLC generated error codes for the Allen-Bradley EtherNet/IP protocol continued on the next page.)

Allen-Bradley – EtherNet/IP Protocol – PLC Error Code Tables

ControlLogix, CompactLogix, & FlexLogix (cont'd)

PLC Errors for Allen-Bradley EtherNet/IP Protocol – CIP Errors (Error code 0xaaaaaa returned from the PLC.)	
Panel Error Code PLC-497 Hex Value	Description
0x010204	Connection Manager: Unconnected Send timed out waiting for a response.
0x010205	Connection Manager: Parameter error in Unconnected send service.
0x010206	Connection Manager: Message too large for Unconnected message service.
0x010207	Connection Manager: Unconnected acknowledge without reply.
0x010301	Connection Manager: No buffer memory available.
0x010302	Connection Manager: Network Bandwidth not available for data.
0x010303	Connection Manager: No Tag filters available.
0x010304	Connection Manager: Not configured to send real-time data.
0x010311	Connection Manager: Port specified in Port segment not available.
0x010312	Connection Manager: Link address specified in port segment not available.
0x010315	Connection Manager: invalid segment type or segment value in path.
0x010316	Connection Manager: Path and Connection not equal in close.
0x010317	Connection Manager: Ether Segment not present or Encoded Value in Network Segment is invalid.
0x010318	Connection Manager: Link address to self invalid.
0x010319	Connection Manager: Resources on Secondary unavailable.
0x01031a	Connection Manager: Connection already established.
0x01031b	Connection Manager: Direct connection already established.
0x01031c	Connection Manager: Miscellaneous.
0x01031d	Connection Manager: Redundant connection mismatch.
0x01031e	Connection Manager: No more consumer resources available in the producing module.
0x01031f	Connection Manager: No connection resources exist for target path.
0x010320 - 0x0107ff	Connection Manager: Vendor specific.
0x020000	Resource unavailable: Connection Manager resources are unavailable to handle service request.
0x030000	Invalid parameter value.
0x040000	Path segment error: The path segment identifier or the segment syntax was not understood by the processing node.
0x050000	Path destination unknown: The path is referencing an object class, instance or structure element that is not known or is not contained in the processing node.
0x060000	Partial transfer: Only part of the expected data was transferred.
0x070000	Connection lost: The messaging connection was lost.
0x080000	Service not supported: The requested service was not implemented or was not defined for this Object Class/Instance.
0x090000	Invalid attribute value: Invalid attribute data detected.
0x0a0000	Attribute list error: An attribute in the Get_Attribute_List or Set_Attribute_List response has a non-zero status.
0x0b0000	Already in requested mode/state: The object is already in the mode/state being requested by the service.
0x0c0000	Object state conflict: The object cannot perform the requested service in its current mode/state.
0x0d0000	Object already exists: The requested instance of object to be created already exists.
0x0e0000	Attribute not settable: A request to modify non-modifiable attribute was received.

(PLC generated error codes for the Allen-Bradley EtherNet/IP protocol for continued on the next page.)

Allen-Bradley – EtherNet/IP Protocol – PLC Error Code Tables ControlLogix, CompactLogix, & FlexLogix (cont'd)

PLC Errors for Allen-Bradley EtherNet/IP Protocol – CIP Errors (Error code 0xaaaaaa returned from the PLC.)	
Panel Error Code PLC-497 Hex Value	Description
0x0f0000	Privilege violation: A permission/privilege check failed.
0x100000	Device state conflict: The device's current mode/state prohibits the execution of the requested service.
0x110000	Reply data too large: The data to be transmitted in the response buffer is larger than the allocated response buffer.
0x120000	Fragmentation of a primitive value: The service specified an operation that is going to fragment a primitive data value. For example, trying to send a 2 byte value to a REAL data type (4 byte).
0x130000	Not enough data: The service did not supply enough data to perform the specified operation.
0x140000	Attribute not supported: The attribute specified in the request is not supported.
0x150000	Too much data: The service supplied more data than was expected.
0x160000	Object does not exist: The object specified does not exist in the device.
0x170000	Service fragmentation sequence not in progress: The fragmentation sequence for this service is not currently active for this data.
0x180000	No stored attribute data: The attribute data of this object was no saved prior to the requested service.
0x190000	Store operation failure: The attribute data of this object was not saved due to a failure during the attempt.
0x1a0000	Routing failure, request packet too large: The service request packet was too large for transmission on a network in the path to the destination.
0x1b0000	Routing failure, response packet too large: The service response packet was too large for transmission on a network in the path from the destination.
0x1c0000	Missing attribute list entry data: The service did not supply an attribute in a list of attributes that was needed by the service to perform the requested behavior.
0x1d0000	Invalid attribute value list: The service is returning the list of attributes supplied with status information for those attributes that were invalid.
0x1e0000	Embedded service error: See Service Packet error list (PLC-498 Error codes) below:
0x1f0000	Vendor specific error: A vendor specific error has been encountered. This occurs when none of the specified errors relate to the error in the device.
0x200000	Invalid parameter: A parameter associated with the request was invalid. This code is used when a parameter does not meet the requirements defined in an Application Object specification.
0x210000	Write-once value or medium already written: An attempt was made to write to a write-once-medium that has already been written or to modify a value that cannot be change once established.
0x220000	Invalid Reply Received: An invalid reply is received (example: service code sent doesn't match service code received.).
0x230000	Reserved by CIP for future extensions.
0x240000	Reserved by CIP for future extensions.

(PLC generated error codes for the Allen-Bradley EtherNet/IP protocol for continued on the next page.)

Allen-Bradley – EtherNet/IP Protocol – PLC Error Code Tables ControlLogix, CompactLogix, & FlexLogix (cont'd)

PLC Errors for Allen-Bradley EtherNet/IP Protocol – Service Packet Errors (Error code 0xaaaaaa returned from the PLC.)	
Panel Error Code PLC-498 Hex Value	Description
0x250000	Key failure in path: The key segment was included as the first segment in the path does not match the destination module. The object specific status shall indicate which part of the key check failed.
0x260000	Path Size Invalid: The size of the path which was sent with the Service Request is either not large enough to allow the Request to be routed to an object or too much routing data was included.
0x270000	Unexpected attribute in list: An attempt was made to set an attribute that is not able to be set at this time.
0x280000	Invalid Member ID: The Member ID specified in the request does not exist in the specified Class/Instance/Attribute.
0x290000	Member not settable: A request to modify a non-modifiable member was received.
0x2a0000	Group 2 only server general failure: This error code may only be reported by DeviceNet group 2 only servers with 4K or less code space and only in place of Service not supported, Attribute not supported and Attribute not settable.
0x2b0000 - 0xcf0000	Reserved by CIP for future extensions.
0xd00000 - 0xff0000	Reserved for Object Class and service errors: This range of error codes is to be used to indicate Object Class specific errors. Use of this range should only be used when errors in this table don't accurately reflect the error encountered.
0x040000	This general status codes that the tag name could not be deciphered. This could mean that the tag name was entered incorrectly or does not exist in the PLC.
0x050000	The particular item referenced (usually instance) could not be found.
0x060000	The amount of data requested would not fit into the response buffer. Partial data transfer has occurred.
0x0a0000	An error has occurred trying to process one of the attributes.
0x130000	Not enough command data/parameters were supplied in the command to execute the service requested.
0x1c0000	An insufficient number of attributes were provided compared to the attribute count.
0x260000	The tag name length specified did not match what was in the message.
0xff0521	You have tried to access beyond the end of the data object.
0xff0721	The abbreviated type does not match the data type of the data object.
0xff0421	The beginning offset was beyond the end of the template.

Allen-Bradley – Micro800 Serial and EtherNet/IP Tag Based PLC Error Code Tables

The following PLC error code tables cover possible errors that are detected by the panel from Allen-Bradley Micro800 PLCs using the tag based serial or EtherNet/IP protocols.



NOTE: The following errors can be generated from the designated PLC, are monitored by the C-more touch panel, and displayed on the touch panel's screen as a hexadecimal value in panel error code PLC-499 message, if active. Please refer to the PLC manufacturer's documentation for additional information.

PLC Errors for Allen-Bradley EtherNet/IP Protocol –Encapsulation Errors (Error code 0xaaaaaa returned from the PLC)	
Panel Error Code PLC-496 Hex Value	Description
0x00000001	The sender issued an invalid or unsupported encapsulation command.
0x00000002	Insufficient memory resources in the receiver to handle the command. You can get this error if the 1761-NET-ENI cannot connect to the PLC serially.
0x00000003	Poorly formed or incorrect data in the data portion of the encapsulation message.
0x00000004 - 0x00000063	Reserved for legacy (Rockwell Automation).
0x00000064	An originator used an invalid session handle when sending an encapsulation message to the target.
0x00000065	The target received a message of invalid length.
0x00000066 - 0x00000068	Reserved for legacy (Rockwell Automation).
0x00000069	Unsupported encapsulation protocol revision.
0x0000006a - 0x0000ffff	Reserved for future expansion.

PLC Errors for Allen-Bradley EtherNet/IP Protocol – CIP Errors (Error code 0xaaaaaa returned from the PLC)	
Panel Error Code PLC-497 Hex Value	Description
0x010100	Connection Manager: Connection in Use or Duplicate Forward Open.
0x010103	Connection Manager: Transport Class and Trigger combination not supported.
0x010106	Connection Manager: Ownership Conflict.
0x010107	Connection Manager: Connection not found at target application.
0x010108	Connection Manager: Invalid connection type (problem with type or priority).
0x010109	Connection Manager: Invalid connection size.
0x010110	Connection Manager: Device not configured.
0x010111	Connection Manager: RPI not supported. Could also be problem with inactivity timeout.
0x010113	Connection Manager: Connection Manager cannot support any more connections.
0x010114	Connection Manager: Either the vendor ID or the Product Code in the key segment did not match the device.
0x010115	Connection Manager: Product Type in the key segment did not match the device.
0x010116	Connection Manager: Major or minor revision information in the key segment did not match the device.

(PLC generated error codes for the Allen-Bradley Micro800 Serial and EtherNet/IP Tag Based PLC continued on the next page)

Allen-Bradley – Micro800 Serial and EtherNet/IP Tag Based PLC Error Code Tables (cont'd)

PLC Errors for Allen-Bradley EtherNet/IP Protocol – CIP Errors (Error code 0xaaaaaa returned from the PLC)	
Panel Error Code PLC-497 Hex Value	Description
0x010117	Connection Manager: Invalid connection point.
0x010118	Connection Manager: Invalid configuration format.
0x010119	Connection Manager: Connection request fails since there is no controlling connection currently open.
0x01011a	Connection Manager: Target application cannot support any more connections.
0x01011b	Connection Manager: RPI is smaller than the Production Inhibit Time.
0x010203	Connection Manager: Connection cannot be closed since the connection has timed out.
0x010204	Connection Manager: Unconnected Send timed out waiting for a response.
0x010205	Connection Manager: Parameter error in Unconnected Send service.
0x010206	Connection Manager: Message too large for Unconnected message service.
0x010207	Connection Manager: Unconnected acknowledge without reply.
0x010301	Connection Manager: No buffer memory available.
0x010302	Connection Manager: Network Bandwidth not available for data.
0x010303	Connection Manager: No Tag filters available.
0x010304	Connection Manager: Not configured to send real-time data.
0x010311	Connection Manager: Port specified in Port segment not available.
0x010312	Connection Manager: Link address specified in port segment not available.
0x010315	Connection Manager: Invalid segment type or segment value in path.
0x010316	Connection Manager: Path and Connection not equal in close.
0x010317	Connection Manager: Ether Segment not present or Encoded Value in Network Segment is invalid.
0x010318	Connection Manager: Link address to self invalid.
0x010319	Connection Manager: Resources on Secondary unavailable.
0x01031a	Connection Manager: Connection already established.
0x01031b	Connection Manager: Direct connection already established.
0x01031c	Connection Manager: Miscellaneous.
0x01031d	Connection Manager: Redundant connection mismatch.
0x01031e	Connection Manager: No more consumer resources available in the producing module.
0x01031f	Connection Manager: No connection resources exist for target path.
0x010320 - 0x0107ff	Connection Manager: Vendor specific.
0x020000	Resource unavailable: Connection Manager resources are unavailable to handle service request.
0x030000	Invalid parameter value.
0x040000	Path segment error: The path segment identifier or the segment syntax was not understood by the processing node.
0x050000	Path destination unknown: The path is referencing an object class, instance or structure element that is not known or is not contained in the processing node.
0x060000	Partial transfer: Only part of the expected data was transferred.
0x070000	Connection lost: The messaging connection was lost.
0x080000	Service not supported: The requested service was not implemented or was not defined for this Object Class/Instance.
0x090000	Invalid attribute value: Invalid attribute data detected.
0x0a0000	Attribute list error: An attribute in the Get_Attribute_List or Set_Attribute_List response has a non-zero status.
0x0b0000	Already in requested mode/state: The object is already in the mode/state being requested by the service.
0x0c0000	Object state conflict: The object cannot perform the requested service in its current mode/state.

(PLC generated error codes for the Allen-Bradley Micro800 Serial and EtherNet/IP Tag Based PLC continued on the next page)

Allen-Bradley – Micro800 Serial and EtherNet/IP Tag Based PLC Error Code Tables (cont'd)

PLC Errors for Allen-Bradley EtherNet/IP Protocol – CIP Errors (Error code 0xa00000 returned from the PLC)	
Panel Error Code PLC-497 Hex Value	Description
0x0d0000	Object already exists: The requested instance of object to be created already exists.
0x0e0000	Attribute not settable: A request to modify non-modifiable attribute was received.
0x0f0000	Privilege violation: A permission/privilege check failed.
0x100000	Device state conflict: The device's current mode/state prohibits the execution of the requested service.
0x110000	Reply data too large: The data to be transmitted in the response buffer is larger than the allocated response buffer.
0x120000	Fragmentation of a primitive value: The service specified an operation that is going to fragment a primitive data value - for example, trying to send a 2 byte value to a REAL data type (4 byte).
0x130000	Not enough data: The service did not supply enough data to perform the specified operation.
0x140000	Attribute not supported: The attribute specified in the request is not supported.
0x150000	Too much data: The service supplied more data than was expected.
0x160000	Object does not exist: The object specified does not exist in the device.
0x170000	Service fragmentation sequence not in progress: The fragmentation sequence for this service is not currently active for this data.
0x180000	No stored attribute data: The attribute data of this object was no saved prior to the requested service.
0x190000	Store operation failure: The attribute data of this object was not saved due to a failure during the attempt.
0x1a0000	Routing failure, request packet too large: The service request packet was too large for transmission on a network in the path to the destination.
0x1b0000	Routing failure, response packet too large: The service response packet was too large for transmission on a network in the path from the destination.
0x1c0000	Missing attribute list entry data: The service did not supply an attribute in a list of attributes that was needed by the service to perform the requested behavior.
0x1d0000	Invalid attribute value list: The service is returning the list of attributes supplied with status information for those attributes that were invalid.
0x1e0000	Embedded service error: See Service Packet error list (PLC-498 Error codes) later in this appendix
0x1f0000	Vendor specific error: A vendor specific error has been encountered. This occurs when none of the specified errors relate to the error in the device.
0x200000	Invalid parameter: A parameter associated with the request was invalid. This code is used when a parameter does not meet the requirements defined in an Application Object specification.
0x210000	Write-once value or medium already written: An attempt was made to write to a write-once-medium that has already been written or to modify a value that cannot be change once established.
0x220000	Invalid Reply Received: An invalid reply is received (example: service code sent doesn't match service code received).
0x230000	Reserved by CIP for future extensions.
0x240000	Reserved by CIP for future extensions.
0x250000	Key failure in path: The key segment was included as the first segment in the path does not match the destination module. The object specific status shall indicate which part of the key check failed.
0x260000	Path Size Invalid: The size of the path which was sent with the Service Request is either not large enough to allow the Request to be routed to an object or too much routing data was included.
0x270000	Unexpected attribute in list: An attempt was made to set an attribute that is not able to be set at this time.
0x280000	Invalid Member ID: The Member ID specified in the request does not exist in the specified Class/Instance/Attribute.
0x290000	Member not settable: A request to modify a non-modifiable member was received.
0x2a0000	Group 2 only server general failure: This error code may only be reported by DeviceNet group 2 only servers with 4K or less code space and only in place of Service not supported, Attribute not supported and Attribute not settable.

(PLC generated error codes for the Allen-Bradley Micro800 Serial and EtherNet/IP Tag Based PLC continued on the next page)

Allen-Bradley – Micro800 Serial and EtherNet/IP Tag Based PLC Error Code Tables (cont'd)

PLC Errors for Allen-Bradley EtherNet/IP Protocol – Service Packet Errors (Error code 0xaaaaaa returned from the PLC)	
Panel Error Code PLC-498 Hex Value	Description
0x2b0000 - 0xcf0000	Reserved by CIP for future extensions.
0xd00000 - 0xff0000 0x040000	Reserved for Object Class and service errors: This range of error codes is to be used to indicate Object Class specific errors. Use of this range should only be used when errors in this table don't accurately reflect the error encountered. This general status codes that the tag name could not be deciphered. This could mean that the tag name was entered incorrectly or does not exist in the PLC.
0x050000	The particular item referenced (usually instance) could not be found.
0x060000	The amount of data requested would not fit into the response buffer. Partial data transfer has occurred.
0x0a0000	An error has occurred trying to process one of the attributes.
0x130000	Not enough command data/parameters were supplied in the command to execute the service requested.
0x1c0000	An insufficient number of attributes were provided compared to the attribute count.
0x260000	The tag name length specified did not match what was in the message.
0xff0521	You have tried to access beyond the end of the data object.
0xff0721	The abbreviated type does not match the data type of the data object.
0xff0421	The beginning offset was beyond the end of the template.

Allen-Bradley – EtherNet/IP Protocol – PLC Error Code Tables

The following PLC error code tables cover possible errors that are detected by the panel from Allen-Bradley PLCs using the EtherNet/IP protocol. This includes MicroLogix 1100, 1400 & SLC 5/05, both using their native Ethernet port, and MicroLogix 1000, 1100, 1200, 1400, 1500, SLC 5/03, 5/04 and 5/05 using an Allen-Bradly ENI Adapter.



NOTE: The following errors can be generated from the designated PLC, are monitored by the C-more touch panel, and displayed on the touch panel's screen as a hexadecimal value in panel error code PLC-499 message, if active. Please refer to the PLC manufacturer's documentation for additional information.

PLC Errors for Allen-Bradley EtherNet/IP Protocol –Encapsulation Errors (Error code 0xaaaaaa returned from the PLC.)	
Panel Error Code PLC-496 Hex Value	Description
0x00000001	The sender issued an invalid or unsupported encapsulation command.
0x00000002	Insufficient memory resources in the receiver to handle the command. You can get this error if the 1761-NET-ENI cannot connect to the PLC serially.
0x00000003	Poorly formed or incorrect data in the data portion of the encapsulation message.
0x00000004 - 0x00000063	Reserved for legacy (Rockwell Automation).
0x00000064	An originator used an invalid session handle when sending an encapsulation message to the target.
0x00000065	The target received a message of invalid length.
0x00000066 - 0x00000068	Reserved for legacy (Rockwell Automation).
0x00000069	Unsupported encapsulation protocol revision.
0x0000006a - 0x0000ffff	Reserved for future expansion.

PLC Errors for Allen-Bradley EtherNet/IP Protocol – CIP Errors (Error code 0xaabbbb returned from the PLC.)	
Panel Error Code PLC-497 Hex Value	Description
0x010100	Connection Manager: Connection in Use or Duplicate Forward Open.
0x010103	Connection Manager: Transport Class and Trigger combination not supported.
0x010106	Connection Manager: Ownership Conflict.
0x010107	Connection Manager: Connection not found at target application.
0x010108	Connection Manager: Invalid connection type (problem with type or priority).
0x010109	Connection Manager: Invalid connection size.
0x010110	Connection Manager: Device not configured.
0x010111	Connection Manager: RPI not supported. Could also be problem with inactivity timeout.
0x010113	Connection Manager: Connection Manager cannot support any more connections.
0x010114	Connection Manager: Either the vendor ID or the Product Code in the key segment did not match the device.
0x010115	Connection Manager: Product Type in the key segment did not match the device.
0x010116	Connection Manager: Major or minor revision information in the key segment did not match the device.
0x010117	Connection Manager: Invalid connection point.
0x010118	Connection Manager: Invalid configuration format.
0x010119	Connection Manager: Connection request fails since there is no controlling connection currently open.
0x01011a	Connection Manager: Target application cannot support any more connections.
0x01011b	Connection Manager: RPI is smaller than the Production Inhibit Time.
0x010203	Connection Manager: Connection cannot be closed since the connection has timed out.
0x010204	Connection Manager: Unconnected Send timed out waiting for a response.
0x010205	Connection Manager: Parameter error in Unconnected send service.

(PLC error code tables continued on the next page.)

Allen-Bradley – EtherNet/IP Protocol – PLC Error Code Tables(cont'd)

PLC Errors for Allen-Bradley EtherNet/IP Protocol – CIP Errors (Error code 0xaabbbb returned from the PLC.)	
Panel Error Code PLC-497 Hex Value	Description
0x010206	Connection Manager: Message too large for Unconnected message service.
0x010207	Connection Manager: Unconnected acknowledge without reply.
0x010301	Connection Manager: No buffer memory available.
0x010302	Connection Manager: Network Bandwidth not available for data.
0x010303	Connection Manager: No Tag filters available.
0x010304	Connection Manager: Not configured to send real-time data.
0x010311	Connection Manager: Port specified in Port segment not available.
0x010312	Connection Manager: Link address specified in port segment not available.
0x010315	Connection Manager: invalid segment type or segment value in path.
0x010316	Connection Manager: Path and Connection not equal in close.
0x010317	Connection Manager: Ether Segment not present or Encoded Value in Network Segment is invalid.
0x010318	Connection Manager: Link address to self invalid.
0x010319	Connection Manager: Resources on Secondary unavailable.
0x01031a	Connection Manager: Connection already established.
0x01031b	Connection Manager: Direct connection already established.
0x01031c	Connection Manager: Miscellaneous.
0x01031d	Connection Manager: Redundant connection mismatch.
0x01031e	Connection Manager: No more consumer resources available in the producing module.
0x01031f	Connection Manager: No connection resources exist for target path.
0x010320 - 0x0107ff	Connection Manager: Vendor specific.
0x020000	Resource unavailable: Connection Manager resources are unavailable to handle service request.
0x030000	Invalid parameter value.
0x040000	Path segment error: The path segment identifier or the segment syntax was not understood by the processing node.
0x050000	Path destination unknown: The path is referencing an object class, instance or structure element that is not known or is not contained in the processing node.
0x060000	Partial transfer: Only part of the expected data was transferred.
0x070000	Connection lost: The messaging connection was lost.
0x080000	Service not supported: The requested service was not implemented or was not defined for this Object Class/Instance.
0x090000	Invalid attribute value: Invalid attribute data detected.
0x0a0000	Attribute list error: An attribute in the Get_Attribute_List or Set_Attribute_List response has a non-zero status.
0x0b0000	Already in requested mode/state: The object is already in the mode/state being requested by the service.
0x0c0000	Object state conflict: The object cannot perform the requested service in its current mode/state.
0x0d0000	Object already exists: The requested instance of object to be created already exists.
0x0e0000	Attribute not settable: A request to modify non-modifiable attribute was received.
0x0f0000	Privilege violation: A permission/privilege check failed.
0x100000	Device state conflict: The device's current mode/state prohibits the execution of the requested service.
0x110000	Reply data too large: The data to be transmitted in the response buffer is larger than the allocated response buffer.
0x120000	Fragmentation of a primitive value: The service specified an operation that is going to fragment a primitive data value. For example, trying to send a 2 byte value to a REAL data type (4 byte).
0x130000	Not enough data: The service did not supply enough data to perform the specified operation.
0x140000	Attribute not supported: The attribute specified in the request is not supported.
0x150000	Too much data: The service supplied more data than was expected.

(PLC generated error codes for the Allen-Bradley EtherNet/IP protocol continued on the next page.)

Allen-Bradley – EtherNet/IP Protocol – PLC Error Code Tables (cont'd)

PLC Errors for Allen-Bradley EtherNet/IP Protocol – CIP Errors (Error code 0xaabbbb returned from the PLC.)	
Panel Error Code PLC-497 Hex Value	Description
0x160000	Object does not exist: The object specified does not exist in the device.
0x170000	Service fragmentation sequence not in progress: The fragmentation sequence for this service is not currently active for this data.
0x180000	No stored attribute data: The attribute data of this object was no saved prior to the requested service.
0x190000	Store operation failure: The attribute data of this object was not saved due to a failure during the attempt.
0x1a0000	Routing failure, request packet too large: The service request packet was too large for transmission on a network in the path to the destination.
0x1b0000	Routing failure, response packet too large: The service response packet was too large for transmission on a network in the path from the destination.
0x1c0000	Missing attribute list entry data: The service did not supply an attribute in a list of attributes that was needed by the service to perform the requested behavior.
0x1d0000	Invalid attribute value list: The service is returning the list of attributes supplied with status information for those attributes that were invalid.
0x1e0000	Embedded service error: See Service Packet error list (PLC-498 Error codes) below:
0x1f0000	Vendor specific error: A vendor specific error has been encountered. This occurs when none of the specified errors relate to the error in the device.
0x200000	Invalid parameter: A parameter associated with the request was invalid. This code is used when a parameter does meet the requirements defined in an Application Object specification.
0x210000	Write-once value or medium already written: An attempt was made to write to a write-once-medium that has already been written or to modify a value that cannot be change once established.
0x220000	Invalid Reply Received: An invalid reply is received (example: service code sent doesn't match service code received.).
0x230000	Reserved by CIP for future extensions.
0x240000	Reserved by CIP for future extensions.
0x250000	Key failure in path: The key segment was included as the first segment in the path does not match the destination module. The object specific status shall indicate which part of the key check failed.
0x260000	Path Size Invalid: The size of the path which was sent with the Service Request is either not large enough to allow the Request to be routed to an object or too much routing data was included.
0x270000	Unexpected attribute in list: An attempt was made to set an attribute that is not able to be set at this time.
0x280000	Invalid Member ID: The Member ID specified in the request does not exist in the specified Class/Instance/Attribute.
0x290000	Member not settable: A request to modify a non-modifiable member was received.
0x2a0000	Group 2 only server general failure: This error code may only be reported by DeviceNet group 2 only servers with 4K or less code space and only in place of Service not supported, Attribute not supported and Attribute not settable.
0x2b0000 - 0xcf0000	Reserved by CIP for future extensions.
0xd00000 - 0xff0000	Reserved for Object Class and service errors: This range of error codes is to be used to indicate Object Class specific errors. Use of this range should only be used when errors in this table don't accurately reflect the error encountered.

(PLC generated error codes for the Allen-Bradley EtherNet/IP protocol continued on the next page.)

Allen-Bradley – EtherNet/IP Protocol – PLC Error Code Tables (cont'd)

PLC Errors for Allen-Bradley EtherNet/IP Protocol – Service Packet Errors (Error code 0xaabbbb returned from the PLC.)	
Panel Error Code PLC-498 Hex Value	Description
0x010000	DST Node is out of buffer space.
0x020000	Cannot guarantee delivery; link layer (The remote node specified does not ACK command).
0x030000	Duplicate token holder detected.
0x040000	Local port is disconnected.
0x050000	Application layer timed out waiting for response.
0x060000	Duplicate node detected.
0x070000	Station is offline.
0x080000	Hardware fault.
0x100000	Illegal command or format. Typical error received from PLC when addressed requested to the PLC does not exist. Usually occurs if memory map has not been expanded in PLC to the range requested from panel.
0x200000	Host has a problem and will not communicate.
0x300000	Remote node host is missing, disconnected, or shut down.
0x400000	Host could not complete function due to hardware fault.
0x500000	Addressing problem or memory protected rungs.
0x600000	Function not allowed due to command protection selection.
0x700000	Processor is in Program Mode.
0x800000	Compatibility mode file missing or communication zone problem.
0x900000	Remote node cannot buffer command.
0xA00000	Wait ACK (1775 KA buffer full).
0xB00000	Not used.
0xC00000	Not used.
0xD00000	Error code in the EXT STS byte. See the error code table below.
0xE00000	Fewer levels specified in address than minimum for any address.
0xF00300	More levels specified in address than system supports.
0xF00400	Symbol not found.
0xF00500	Symbol is of improper format.
0xF00600	Address does not point to something usable.
0xF00700	File is wrong size.
0xF00800	Cannot complete request, situation has changed since start of the command.
0xF00900	Data or file size is too large.
0xF00900	Transaction size plus word address is too large.
0xF00B00	Access denied; improper privilege. This will occur if data file is set to constant or protected.
0xF00C00	Condition cannot be generated; resource is not available.
0xF00D00	Condition already exists; resource is readily available.
0xF00E00	Command cannot be executed.
0xF00F00	Histogram overflow.
0xF01000	No access.
0xF01100	Illegal data type.
0xF01200	Invalid parameter or invalid data.
0xF01300	Address reference exists to deleted area.
0xF01400	Command execution failure for unknown reason; possible histogram overflow.
0xF01500	Data conversion error.

(PLC generated error codes for the Allen-Bradley EtherNet/IP protocol continued on the next page.)

Allen-Bradley – EtherNet/IP Protocol – PLC Error Code Tables (cont'd)

PLC Errors for Allen-Bradley EtherNet/IP Protocol – Service Packet Errors (Error code 0xaabbbb returned from the PLC.)	
Panel Error Code PLC-498 Hex Value	Description
0xF01600	Scanner not able to communicate with 1771 rack adapter.
0xF01700	Type mismatch.
0xF01800	1771 module response was not valid.
0xF01900	Duplicated label.
0xF02200	Remote rack fault.
0xF02300	Timeout.
0xF02400	Unknown error.
0xF01A00	File is open; another node owns it.
0xF01B00	Another node is the program owner.
0xF01C00	Reserved.
0xF01D00	Reserved.
0xF01E00	Data table element protection violation.
0xF01F00	Temporary internal problem.

Generic EtherNet IP Protocol – PLC Error Codes

Only errors as listed in the Touch Panel Error Code Table shown previously in this Appendix can occur when using the Generic Ethernet IP protocol, there are no PLC generated errors.

GE 90-30 – Panel Error Code PLC-499 Explanation

The PLC-499 error code is used to show any errors that are generated by the connected PLC. The PLC-499 error message includes a four-digit hexadecimal value embedded in the message. This value can be looked up in the specific PLC's error tables to determine the cause of the error. The possible PLC generated error codes for the GE 90-30 communication protocol are represented by a hexadecimal value as shown in the following message example.

GE 90-30 Error Code PLC-499 Message Example

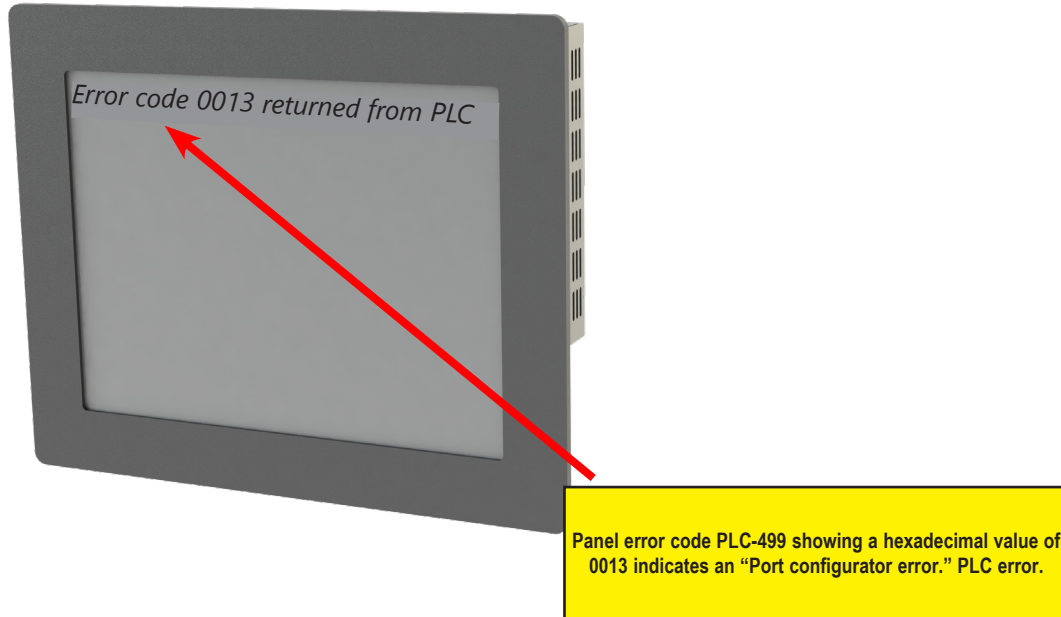

GE 90-30 SNPX Protocol – PLC Error Code Tables

The following table lists the errors that can be generated by the GE 90-30 PLC when using the SNPX protocol.



NOTE: The following errors can be generated from the designated PLC, are monitored by the C-more touch panel, and displayed on the touch panel's screen as a hexadecimal value in panel error code PLC-499 message, if active. Please refer to the PLC manufacturer's documentation for additional information.

PLC Errors for GE 90-30 SNPX Protocol (Major)	
Panel Error Code PLC-499 Hex Value	Description
No error	Successful completion. (This is the expected completion value in the COMMREQ Status Word.)
0x0002	Insufficient Privilege. For Series 90-70 PLC, the minor error code contains the privilege level required for the service request.
0x0004	Protocol Sequence Error. The CPU has received a message that is out of order.
0x0005	Service Request Error, the minor error code contains the specific error code.
0x0006	Illegal Mailbox Type. Service request mailbox type is either undefined or unexpected.
0x0007	The PLC CPU's Service Request Queue is full. The master should retry later. It is recommended that the master wait a minimum of 10 msec before sending another service request.
0x000A	SNP DOS Driver Error. The minor error code contains the specific error code.
0x000B	Illegal Service Request. The requested service is either not defined or not supported. (This value is returned in lieu of the actual 01h value passed in the SNP error message, to avoid confusion with the normal successful COMMREQ completion.)
0x000C	Local SNP/SNP-X Error. An error occurred within the SNP task in the CMM module in this PLC. This error may occur in either an SNP master or an SNP slave. The minor error code contains the specific error code.
0x000D	Remote SNP Error. An error occurred within the SNP slave task in the CMM module in the remote PLC. The minor error code contains the specific error code.
0x000E	Autodial Error. An error occurred while attempting to send a command string to an attached external modem. The minor error code contains the specific error code.
0x000F	SNP-X slave error. An error occurred within the SNPX task in the remote slave device. The minor error code contains the specific error code.
0x0013	Port configurator error.
0x0050	Problem with sending mail to the slave Service Request task. (Series 90-70 PLC CPUs only)
0x0051	Problem with getting mail from the slave Service Request task. (Series 90-70 PLC CPUs only)
0x0055	Slave SNP task timed out before receiving an SRP response. (Series 90-70 PLC CPUs only)
0x0056	Slave SNP task could not find the requested datagram connection. (Series 90-70 PLC CPUs only)
0x0057	Slave SNP task encountered an error in trying to write the datagram. (Series 90-70 PLC CPUs only)
0x0058	Slave SNP task encountered an error in trying to update the datagram. (Series 90-70 PLC CPUs only)

(PLC generated error codes for the GE 90-30 SNPX protocol continued on the next page.)

GE 90-30 SNPX Protocol – PLC Error Code Tables (cont'd)

PLC Errors for GE 90-30 SNPX Protocol (Minor-Major)	
Panel Error Code PLC-499 Hex Value	Description
PLC Error 0x010C	WAIT-type COMMREQ is not permitted; must use NOW AIT-type.
PLC Error 0x010E	Not used
PLC Error 0x010F	The service request code in an X-Request message is unsupported or invalid at this time. This error may occur if an SNP-X communication session has not been successfully established at the slave device.
PLC Error 0x020C	COMMREQ command is not supported.
PLC Error 0x020E	The modem command string length exceeds 250 characters.
PLC Error 0x020F	Insufficient privilege level in the slave PLC CPU for the requested SNP-X service. Password protection at PLC CPU may be preventing the requested service.
PLC Error 0x0213	Unsupported COMMREQ. These errors are only generated when there is no protocol currently being run on a port, and the port receives a COMMREQ. (The port may be disabled or an error has occurred in processing a new configuration).
PLC Error 0x030C	SNP communication is not active. Must initiate a new SNP communication by sending an Attach or Long Attach COMMREQ.
PLC Error 0x030E	COMMREQ Data Block Length is too small. Output command string data is missing or incomplete.
PLC Error 0x030F	Invalid slave memory type in X-Request message.
PLC Error 0x0313	Invalid COMMREQ length.
PLC Error 0x040C	SNP slave did not respond to Attach message from master.
PLC Error 0x040E	Serial output timeout. The CMM module was unable to transmit the modem autodial output from the serial port. (May be due to missing CTS signal when the CMM is configured to use hardware flow control.)
PLC Error 0x040F	Invalid slave memory address or range in X-Request message.
PLC Error 0x0413	Invalid COMMREQ status word location.
PLC Error 0x050C	Unable to write SNP Status Word to local PLC memory; may be due to invalid Status Word memory type or address.
PLC Error 0x050E	Response was not received from modem. Check modem and cable.
PLC Error 0x050F	Invalid data length in X-Request message. Data length must be non-zero, and may not exceed decimal 1000 bytes.
PLC Error 0x0513	Invalid COMMREQ data.
PLC Error 0x060C	Master device memory type is not valid in this PLC.
PLC Error 0x060E	Modem responded with BUSY. Modem is unable to complete the requested connection. The remote modem is already in use; retry the connection request at a later time.
PLC Error 0x060F	X-Buffer data length does not match the service request in X-Request message. The X-Buffer message length is obtained from the Next Message Length field in the X-Request message; the length of the data within the buffer message is always the message length.
PLC Error 0x070C	Master device memory address or length is zero.
PLC Error 0x070E	Modem responded with NO CARRIER. Modem is unable to complete the requested connection. Check the local and remote modems and the telephone line.
PLC Error 0x070F	Queue Full indication from Service Request Processor in slave PLC CPU. The slave is temporarily unable to complete the service request. The master should try again later. It is recommended that the master wait at least 10 msec before repeating the X-Request.
0x080C	Unable to read or write master device memory locations specified in COMMREQ. Usually caused by invalid memory address for this PLC. SNP message exchange may have taken place.
0x080E	Modem responded with NO DIALTONE. Modem is unable to complete the requested connection. Check the modem connections and the telephone line.
0x080F	Service Request Processor response exceeds 1000 bytes; the SNP-X slave device cannot return the data in an X-Response message. (This error applies to CMM module only.)

(PLC generated error codes for the GE 90-30 SNPX protocol continued on the next page.)

GE 90-30 SNPX Protocol – PLC Error Code Tables (cont'd)

PLC Errors for GE 90-30 SNPX Protocol (Minor-Major) (cont'd)	
Panel Error Code PLC-499 Hex Value	Description
0x090C	Master device memory data length exceeds maximum data size of CMM module (2048 bytes). Must use a smaller data length. Use multiple COMMREQs if total data length exceeds this maximum value.
0x090E	Modem responded with ERROR. Modem is unable to complete the requested command. Check the modem command string and modem.
0x0A0C	Slave device memory type is missing or not valid.
0x0A0E	Modem responded with RING, indicating that the modem is being called by another modem. Modem is unable to complete the requested command. Retry the modem command at a later time.
0x0B0C	Slave device memory address is missing or zero.
0x0B0E	An unknown response was received from the modem. Modem is unable to complete the requested command. Check the modem command string and modem. The modem response is expected to be either CONNECT or OK.
0x0C0C	COMMREQ Data Block Length is too small. (When expected COMMREQ length is 6 words or less. An improper length may cause other minor error codes 6-11.)
0x0D0C	Invalid Diagnostic Status Word (DSW) starting word or length.
0x0E0C	Invalid maximum SNP message data size. Must be an even value from 42 to 2048.
0x0F0C	Invalid Privilege Level. Must be 0 through 4 or -1.
0x100C	Invalid Fault Table selector. Must be 1 for I/O Fault Table, or 2 for PLC Fault Table.
0x100F	Unexpected Service Request Processor error. (This error applies to CMM module only; the unexpected SRP error code is saved in the Diagnostic Status Words in the CMM module.)
0x110C	Invalid Fault Table starting index. Must be 1-32 for I/O Fault Table, or 1-16 for PLC.
0x120C	Invalid fault count. Must be 1-32 for I/O Fault Table, or 1-16 for PLC Fault Table.
0x130C	Invalid Set PLC Date/Time mode. Must be 1-4.
0x140C	Invalid Set PLC Date/Time date, time, or day-of-week value.
0x150C	Unable to retrieve master device PLC time/date from PLC CPU.
0x150F	Requested service is not permitted in a Broadcast request. The master must direct the X-Request message to a specific SNP-X slave device.
0x160C	Invalid slave PLC type. Must be 0 for Series 90-70, or 1 for Series 90-30 or Series 90-20.
0x170C	Invalid datagram type. Must be 01h for normal datagram, or 81h (129) for permanent datagram.
0x180C	Missing or too many datagram point formats. Must be 1-32.
0x190C	Invalid datagram point format data.
0x1A0C	Datagram area size is too small to include data for all specified point formats.
0x1B0C	Invalid number of Control Program Names. Must be 1-8.
0x1C0C	SNP-X Request exceeds maximum data size (1000 bytes). Must use a smaller data length. Use multiple COMMREQs if necessary.
0x1D0C	Invalid SNP-X communication session type. Must be 0 for a single slave device, or 1 for multiple slave devices.
0x1E0C	Illegal destination SNP ID specified for SNP-X slave. Must be 0-7 ASCII characters, plus a terminating null character (00h). The Null SNP ID (eight bytes of 00h) may be used to specify any single device. The Broadcast SNP ID (eight bytes of FFh) may be use to specify all slave devices on the serial link.
0x1F0C	Destination SNP ID does not match SNP-X session type. The Broadcast SNP ID is not permitted in a single-slave SNP-X session. The Null SNP ID is not permitted in a multiple-slave SNP-X session.

(PLC generated error codes for the GE 90-30 SNPX protocol continued on the next page.)

GE 90-30 SNPX Protocol – PLC Error Code Tables (cont'd)

PLC Errors for GE 90-30 SNPX Protocol (Minor-Major) (cont'd)	
Panel Error Code PLC-499 Hex Value	Description
0x200C	Inactivity timeout (T3'). The SNP slave has not received any new SNP messages within the configured T3' time interval.
0x200F	Invalid Message Type field in a received X-Request message. The message type of an X-Request message must be 58h = 'X'.
0x210C	A Parity error has occurred on an Attach, Attach Response, or Update Real-time Datagram message. Communications have not been established.
0x210F	Invalid Next Message Type or Next Message Length field in a received X Request message. If this request does not use a buffer (0-2 bytes of data), the Next Message Type must be zero. If this request will be followed with a buffer message (more than 2 byte.)), the Next Message Type must be 54h = 'T', and the Next Message Length must specify the length of the X-Buffer message. Valid X-Buffer message lengths are 9-1008 bytes (data length plus 8 bytes).
0x220C	A BCC (Block Check Code) error has occurred on an Attach, Attach Response, or Update Realtime Datagram message. Communications have not been established.
0x220F	Invalid Message Type field in a received X-Buffer message. The message type of an X-Buffer message must be 54h = 'T'.
0x230C	A Framing or Overrun serial error has occurred on an Attach, Attach Response, or Update Realtime Datagram message. Communications have not been established.
0x230F	Invalid Next Message Type field in a received X-Buffer message. Since an X-Buffer message is never followed by another message, the Next Message Type must always be zero.
0x240C	An invalid SNP message type was received when an Attach, Attach Response, or Update Realtime Datagram message was required. Communications have not been established.
0x250C	An invalid next message length value was specified in an Attach, Attach Response, or Update Realtime Datagram message. Communications have not been established.
0x260C	An unexpected SNP message type was received when an Attach, Attach Response, or Update Realtime Datagram was required. Communications have not been established.
0x270C	Another Break was received while SNP slave was waiting for an Attach or Update Realtime Datagram message.
0x280C	An SNP message has been sent and retried the maximum number of times. A maximum of two retries are permitted. A retry is caused by a NAK from the remote SNP device.
0x290C	A received SNP message has been NAKed the maximum number of two times. The NAKed message may be retransmitted a maximum of two times.
0x2A0C	An unknown message was received when an acknowledge (ACK or NAK) was required.
0x2B0C	Sequence Error. An unexpected SNP message type was received.
0x2C0C	Received SNP message contains bad next message length value.
0x2D0C	Acknowledge timeout. An acknowledge (ACK or NAK) was not received within the configured T2 time interval. A slave device may generate this error if the master device has aborted after maximum response NAKs and does not NAK the next response retry.
0x2E0C	Response timeout. The SNP Master did not receive an SNP Response message within the configured T5' time interval.
0x2F0C	Buffer message timeout. An expected Text Buffer or Connection Data message was not received within the configured T5'' time interval.
0x300C	Serial output timeout. The CMM module was unable to transmit a Break, an SNP message, or SNP acknowledge (ACK or NAK) from the serial port. (May be due to missing CTS signal when the CMM module is configured to use hardware flow control.)
0x310C	SNP slave did not receive a response from the Service Request Processor in the PLC CPU.
0x320C	COMMREQ timeout. The COMMREQ did not complete within the configured time interval.
0x330C	An SNP Request or Response was aborted prior to completion due to reception of a Break.
0x340C	PLC backplane communications error
0x350C	Invalid Piggyback Status data memory type or address. Communications have not been established.
0x360C	Invalid SNP Slave SNP ID. Must be a 0-7 ASCII characters, plus a terminating null character (00h). The Null SNP ID (eight bytes of 00h) may be used to specify any single slave device.

(PLC generated error codes for the GE 90-30 SNPX protocol continued on the next page.)

GE 90-30 SNPX Protocol – PLC Error Code Tables (cont'd)

PLC Errors for GE 90-30 SNPX Protocol (Minor-Major) (cont'd)	
Panel Error Code PLC-499 Hex Value	Description
0x370C	The SNP master has received a response message containing an unexpected data length. Usually indicates a problem with the remote SNP slave device. May occur when Series 90-70 commands (Task Memory or Program Block Memory Read/Write) are issued to a Series 90-30 slave device.
0x380C	Response code in received SNP-X response message does not match expected value. (Response code must equal the request code +80h.)
0x390C	SNP-X Response message exceeds maximum data size (decimal 1000 bytes). Data in the Response is ignored.
0x400C	A parity error has occurred on an X-Attach Response message when establishing a new SNP-X communication session. Communications have not been established.
0x400D	The requested service is not supported by the SNP slave.
0x400F	Serial output timeout. The slave was unable to transmit an SNP-X message from the serial port. (May be due to missing CTS signal when the CMM module is configured to use hardware flow control.)
0x410C	A framing or overrun error has occurred on an X-Attach Response message when establishing a new SNP-X communication session. Communications have not been established.
0x410D	SNP slave on CMM module requires PLC CPU privilege level 2 to operate. The SNP slave has rejected a request to change to a higher or lower privilege level.
0x410F	An SNP-X request was aborted prior to completion due to reception of a Break.
0x420C	A BCC (Block Check Code) error has occurred on an X-Attach Response message when establishing a new SNP-X communication session. Communications have not been established.
0x420D	SNP Request or Response message exceeds maximum data length of the CMM module. (Total data length for Mailbox and all following Buffer messages is 2048 bytes.) The master must use a smaller data length. Use multiple requests if total data length exceeds the maximum value.
0x420F	An X-Buffer message was received containing greater than 1000 bytes of data. The data is ignored.
0x430C	An invalid message type was received when an X-Attach Response was required when establishing a new SNP-X communication session. Communications have not been established.
0x430D	Improper Write Datagram message format. Series 90-70 slave devices use a different format for this message than Series 90-30 or Series 90-20 slave devices. The master must use the proper message format for this SNP slave device. (The SNP master in the CMM module sends this message as part of the Establish Datagram COMMREQ command. The datagram has been partially established, but is not usable; the datagram should be cancelled by using the Datagram ID returned by the COMMREQ.)
0x430F	The SNP-X slave did not receive a response from the Service Request Processor in the PLC CPU.
0x440C	An invalid next message type value was detected in an X-Attach Response message when establishing a new SNP-X communication session. Communications have not been established.
0x440D	A datagram error occurred in a Series 90-70 slave device (dual-port error).
0x440F	PLC backplane communications error.
0x450C	An invalid response code was detected in an X-Attach Response message when establishing a new SNP-X communication session. Communications have not been established.
0x460C	An expected X-Attach Response message was not received within the response timeout interval when establishing a new SNP-X communication session. The master has retried the X-Attach message twice without receiving a response. Communications have not been established.
0x500C	A parity error has occurred on an X-Attach Response message when re-establishing an existing SNP-X communication session. Communications have not been established.
0x500F	A parity error has occurred in a received X-Attach message.
0x510C	A framing or overrun error has occurred on an X-Attach Response message when re-establishing an existing SNP-X communication session. Communications have not been established.

(PLC generated error codes for the GE 90-30 SNPX protocol continued on the next page.)

GE 90-30 SNPX Protocol – PLC Error Code Tables (cont'd)

PLC Errors for GE 90-30 SNPX Protocol (Minor-Major) (cont'd)	
Panel Error Code PLC-499 Hex Value	Description
0x520C	A BCC (Block Check Code) error has occurred on an X-Attach Response message when re-establishing an existing SNP-X communication session. Communications have not been established.
0x520F	A BCC (Block Check Code) error has occurred in a received X-Attach message.
0x530C	An invalid message type was received when an X-Attach Response was required when re-establishing an existing SNP-X communication session. Communications have not been established.
0x530F	An invalid Message Type was received when an X-Attach message was required. (For an X-Attach message, the message type must be 58h = 'T'.)
0x540C	An invalid Next Message Type value was detected in an X-Attach Response message when re-establishing an existing SNP-X communication session. Communications have not been established.
0x540F	An invalid Next Message Type value was detected in a received X-Attach message. (For an X-Attach message, the Next Message Length must be zero.)
0x550C	An invalid response code was detected in an X-Attach Response message when re-establishing an existing SNP-X communication session. Communications have not been established.
0x550F	An invalid request code was detected in a received X-Attach message.
0x560C	An expected X-Attach Response message was not received within the response timeout interval when re-establishing an existing SNP-X communication session. The master has retried the X-Attach message twice without receiving a response. Communications have not been established.
0x600C	A parity error has occurred on an X-Response message.
0x600F	A parity error has occurred in a received X-Request message.
0x610C	A framing or overrun error has occurred on an X-Response message.
0x610F	A framing or overrun error has occurred in a received X-Request message.
0x620C	A BCC (Block Check Code) error has occurred on an X-Response message.
0x620F	A BCC (Block Check Code) error has occurred in a received X-Request message.
0x630C	An invalid message type was received when an X-Response message was required.
0x640C	An invalid next message type value was detected in an X-Response message.
0x650C	An invalid response code was detected in an X-Response message.
0x660C	An expected X-Response message was not received within the response time.
0x700C	A parity error has occurred on an Intermediate Response message.
0x700F	A parity error has occurred in a received X-Buffer message.
0x710C	A framing or overrun error has occurred on an Intermediate Response message.
0x710F	A framing or overrun error has occurred in a received X-Buffer message.
0x720C	A BCC (Block Check Code) error has occurred on an Intermediate Response message.
0x720F	A BCC (Block Check Code) error has occurred in a received X-Buffer message.
0x730C	An invalid message type was received when an Intermediate Response message was required.
0x730F	An expected X-Buffer message was not received.
0x740C	An invalid next message type value was detected in an Intermediate Response message.
0x750C	An invalid response code was detected in an Intermediate Response message.
0x760C	An expected Intermediate Response message was not received within the response timeout interval.
0x8D0A	Bad DOS Version. Must have DOS 2.0, or later, to support the SNP DOS Driver.
0x8E0A	PC Serial port configured for SNP Master driver is not open; no communication can take place.
0x8F0A	Out-of-Sequence SNP message. SNP message type received was not the type expected.
0x900A	Bad SNP BCC encountered. Transmission was aborted after maximum retries due to a bad Block Check Code.
0x910A	Bad SNP communication. Transmission was aborted after maximum retries due to serial errors (that is, parity, overrun, or framing errors).

(PLC generated error codes for the GE 90-30 SNPX protocol continued on the next page.)

GE 90-30 SNPX Protocol – PLC Error Code Tables (cont'd)

PLC Errors for GE 90-30 SNPX Protocol (Minor-Major) (cont'd)	
Panel Error Code PLC-499 Hex Value	Description
0x920A	No SNP communication. Either communication has been lost or a communication session has not been established.
0xC105	Invalid block state transition.
0xC205	The OEM key is NULL (inactive).
0xC305	Text length does not match traffic type.
0xC405	Verify with FA Card or EEPROM failed.
0xC505	No task-level Rack/Slot configuration to read or delete.
0xC605	Control Program (CP) tasks exist but requestor not logged into main CP.
0xC705	Passwords are set to inactive and cannot be enabled or disabled.
0xC805	Password(s) already enabled and can not be forced inactive.
0xC905	Login using non-zero buffer size required for block commands.
0xCA05	Device is write-protected.
0xCB05	A comm or write verify error occurred during save or restore.
0xCC05	Data stored on device has been corrupted and is no longer reliable.
0xCD05	Attempt was made to read a device but no data has been stored on it.
0xCE05	Specified device has insufficient memory to handle request.
0xCF05	Specified device is not available in the system (not present).
0xD005	One or more PLC modules configured have unsupported revision.
0xD105	Packet size or total program size does not match input.
0xD205	Invalid write mode parameter.
0xD305	User Program Module (UPM) read or write exceeded block end.
0xD405	Mismatch of configuration checksum.
0xD505	Invalid block name specified in datagram.
0xD605	Total datagram connection memory exceeded.
0xD705	Invalid datagram type specified.
0xD805	Point length not allowed.
0xD905	Transfer type invalid for this Memory Type selector.
0xDA05	Null pointer to data in Memory Type selector.
0xDB05	Invalid Memory Type selector in datagram.
0xDC05	Unable to find connection address.
0xDD05	Unable to locate given datagram connection ID.
0xDE05	Size of datagram connection invalid.
0xDF05	Invalid datagram connection address.
0xE005	Service in process cannot login.
0xE105	No I/O configuration to read or delete.
0xE205	IOS could not delete configuration, or bad type.
0xE305	CPU revision number does not match.
0xE405	Memory Type for this selector does not exist.
0xE505	DOS file area not formatted.
0xE605	CPU model number does not match.
0xE705	Configuration is not valid.
0xE805	No user memory is available to allocate.
0xE905	Memory Type selector not valid in context.
0xEA05	Not logged in to process service request.
0xEB05	Task unable to be deleted.

(PLC generated error codes for the GE 90-30 SNPX protocol continued on the next page.)

GE 90-30 SNPX Protocol – PLC Error Code Tables (cont'd)

PLC Errors for GE 90-30 SNPX Protocol (Minor-Major) (cont'd)	
Panel Error Code PLC-499 Hex Value	Description
0xEC05	Task unable to be created.
0xED05	VME bus error encountered.
0xEE05	Could not return block sizes.
0xEF05	Programmer is already attached.
0xF005	Request only valid in stop mode.
0xF105	Request only valid from programmer.
0xF205	Invalid program cannot log in.
0xF305	I/O configuration mismatch.
0xF405	Invalid input parameter in request.
0xF505	Invalid password.
0xF605	Invalid sweep state to set.
0xF705	Required to log in to a task for service.
0xF805	Invalid Task Name referenced.
0xF905	Task address out of range.
0xFA05	Cannot replace I/O module.
0xFB05	Cannot clear I/O configuration.
0xFC05	I/O configuration is invalid.
0xFD05	Unable to perform auto configuration.
0xFE05	No privilege for attempted operation.
0xFF05	Service Request Error has been aborted.

Mitsubishi FX Protocol – PLC Error Codes

Only errors as listed in the Touch Panel Error Code Table shown previously in this Appendix can occur when using the Mitsubishi FX protocol, there are no PLC generated errors.

Omron – Panel Error Code PLC-499 Explanation

The PLC-499 error code is used to show any errors that are generated by the connected PLC. The PLC-499 error message includes a four-digit hexadecimal value embedded in the message. This value can be looked up in the specific PLC's error tables to determine the cause of the error. The possible PLC generated error codes for the Omron Host Link and FINS communication protocol are represented by a hexadecimal value as shown in the following message example.

Omron Error Code PLC-499 Message Example

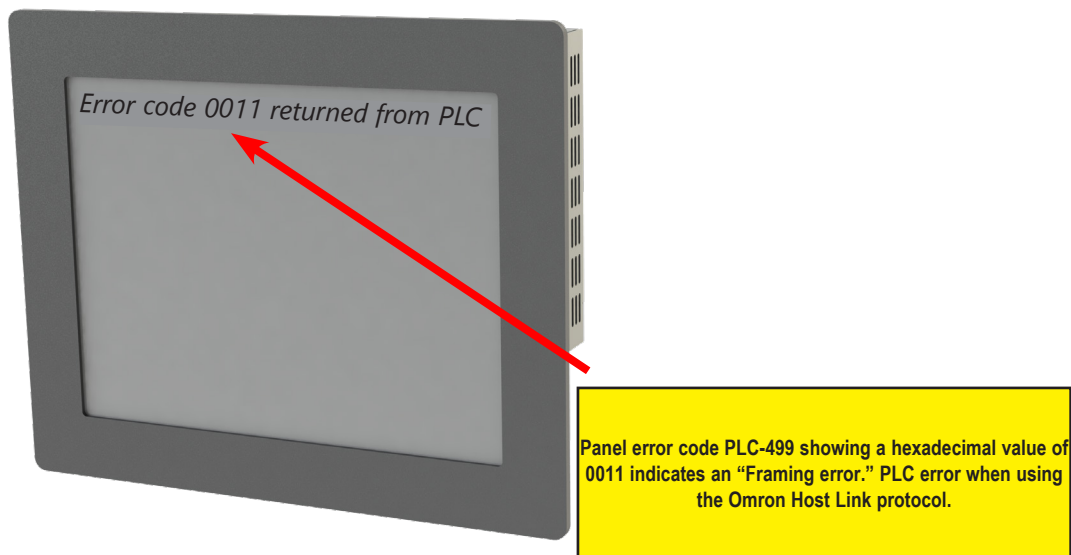

Omron Host Link Protocol – PLC Error Code Table

The following table lists the errors that can be generated by the Omron PLC when using the Host Link protocol.



NOTE: The following errors can be generated from the designated PLC, are monitored by the C-more touch panel, and displayed on the touch panel's screen as a hexadecimal value in panel error code PLC-499 message, if active. Please refer to the PLC manufacturer's documentation for additional information.

PLC Error Codes for Omron Host Link	
Panel Error Code PLC-499 Hex Value	Description
0x0000	Normal Completion.
0x0001	Not executable in RUN mode.
0x0002	Not executable in MONITOR mode.
0x0003	Not executable with PROM mounted.
0x0004	Address over (data overflow).
0x000B	Not executable in PROGRAM mode.
0x000C	Not executable in DEBUG mode.
0x000D	Not executable in LOCAL mode.
0x0010	Parity error.
0x0011	Framing error.
0x0012	Overrun.
0x0013	FCS error.
0x0014	Format error (parameter length error).
0x0015	Entry number data error (parameter error, data code error, data length error).
0x0016	Instruction not found.
0x0018	Frame length error.
0x0019	Not executable (due to Un-executable error clear, non-registration of I/O table, etc.).
0x0020	I/O table generation impossible (unrecognized remote I/O unit, channel over, duplication of optical transmitting I/O unit).
0x00A0	Abort due to parity error in transmit data under process.
0x00A1	Abort due to framing error in transmit data under process.
0x00A2	Abort due to overrun in transmit data under process.
0x00A3	Abort due to FCS error in transmit data under process.
0x00A4	Abort due to format error in transmit data under process.
0x00A5	Abort due to frame length error in transmit data under process.
0x00A8	Abort due to entry number data error in transmit data under process.
0x00B0	Un-executable due to program area capacity other than 16k bytes.

Omron FINS Protocol – PLC Error Code Table

The following table lists the errors that can be generated by the Omron PLC when using the FINS protocol.



NOTE: The following errors can be generated from the designated PLC, are monitored by the C-more touch panel, and displayed on the touch panel's screen as a hexadecimal value in panel error code PLC-499 message, if active. Please refer to the PLC manufacturer's documentation for additional information.

PLC Error Codes for Omron FINS	
Panel Error Code PLC-499 Hex Value	Description
0x0000	Normal Completion.
0x0001	Service Canceled.
0x0101	Local Error: Local node not in network.
0x0102	Local Error: Token Timeout.
0x0103	Local Error: Retries Failed.
0x0104	Local Error: Too many send frames.
0x0105	Local Error: Node address range error.
0x0106	Local Error: Node Address Duplication.
0x0201	Destination Node Error: Destination Node not in network.
0x0202	Destination Node Error: Unit Missing.
0x0203	Destination Node Error: Third Node missing.
0x0204	Destination Node Error: Destination Node busy.
0x0205	Destination Node Error: Response Timeout.
0x0301	Controller Error: Communications Controller Error.
0x0302	Controller Error: CPU Unit Error.
0x0303	Controller Error: Controller Error.
0x0304	Controller Error: Unit number Error.
0x0401	Service Unsupported: Undefined Command.
0x0402	Service Unsupported: Not supported by Model/Version.
0x0501	Routing Table Error: Destination address setting error.
0x0502	Routing Table Error: No routing tables.
0x0503	Routing Table Error: Routing table error.
0x0504	Routing Table Error: Too many delays.
0x1001	Command Format Error: Command too long.
0x1002	Command Format Error: Command too short.
0x1003	Command Format Error: Elements/Data don't match.
0x1004	Command Format Error: Command format error.
0x1005	Command Format Error: Header Error.
0x1101	Parameter Error: Area classification missing.
0x1102	Parameter Error: Access Size Error.
0x1103	Parameter Error: Address range error.
0x1104	Parameter Error: Address range exceeded.
0x1106	Parameter Error: Program Missing.
0x1109	Parameter Error: Relational Error.
0x110A	Parameter Error: Duplicate Data Access.
0x110B	Parameter Error: Response too long.
0x110C	Parameter Error: Parameter Error.
0x2002	Read Not Possible: Protected.

(PLC generated error codes for the Omron FINS protocol continued on the next page.)

Omron FINS Protocol – PLC Error Code Table (cont'd)

PLC Error Codes for Omron FINS	
Panel Error Code PLC-499 Hex Value	Description
0x2003	Read Not Possible: Table missing.
0x2004	Read Not Possible: Data missing.
0x2005	Read Not Possible: Program missing.
0x2006	Read Not Possible: File missing.
0x2007	Read Not Possible: Data mismatch.
0x2101	Write Not Possible: Read Only.
0x2102	Write Not Possible: Protected - cannot write data link table.
0x2103	Write Not Possible: Cannot register.
0x2105	Write Not Possible: Program missing.
0x2106	Write Not Possible: File missing.
0x2107	Write Not Possible: File name already exists.
0x2108	Write Not Possible: Cannot change.
0x2201	Not executable in current mode: Not possible during execution.
0x2202	Not executable in current mode: Not possible while running.
0x2203	Not executable in current mode: Wrong PLC mode (Program).
0x2204	Not executable in current mode: Wrong PLC mode (Debug).
0x2205	Not executable in current mode: Wrong PLC mode (Monitor).
0x2206	Not executable in current mode: Wrong PLC mode (Run).
0x2207	Not executable in current mode: Specified node not polling node.
0x2208	Not executable in current mode: Step cannot be executed.
0x2301	No such device: File device missing.
0x2302	No such device: Missing memory.
0x2303	No such device: Clock missing.
0x2401	Cannot Start/Stop: Table missing.
0x2502	Unit Error: Memory Error.
0x2503	Unit Error: I/O setting Error.
0x2504	Unit Error: Too many I/O points.
0x2505	Unit Error: CPU bus error.
0x2506	Unit Error: I/O Duplication.
0x2507	Unit Error: I/O bus error.
0x2509	Unit Error: SYSMAC BUS/2 error.
0x250A	Unit Error: CPU Bus Unit Error.
0x250D	Unit Error: SYSMAC BUS No. duplication.
0x250F	Unit Error: Memory Error.
0x2510	Unit Error: SYSMAC BUS terminator missing.
0x2601	Command Error: No protection.
0x2602	Command Error: Incorrect password.
0x2604	Command Error: Protected.
0x2605	Command Error: Service already executing.
0x2606	Command Error: Service stopped.
0x2607	Command Error: No execution right.
0x2608	Command Error: Settings not complete.
0x2609	Command Error: Necessary items not set.
0x260A	Command Error: Number already defined.
0x260B	Command Error: Error will not clear.
0x3001	Access Right Error: No access right.
0x4001	Abort: Service aborted.

Omron – Panel Error Code PLC-495 Explanation

The PLC-495 error code is used to show any errors that are generated by the connected PLC. The PLC-495 error message includes a four-digit hexadecimal value embedded in the message. This value can be looked up in the specific PLC’s error tables to determine the cause of the error. The possible PLC generated error codes for the Omron CS/CJ FINS Ethernet communication protocol are represented by a hexadecimal value as shown in the following message example.

Omron Error Code PLC-495 Message Example

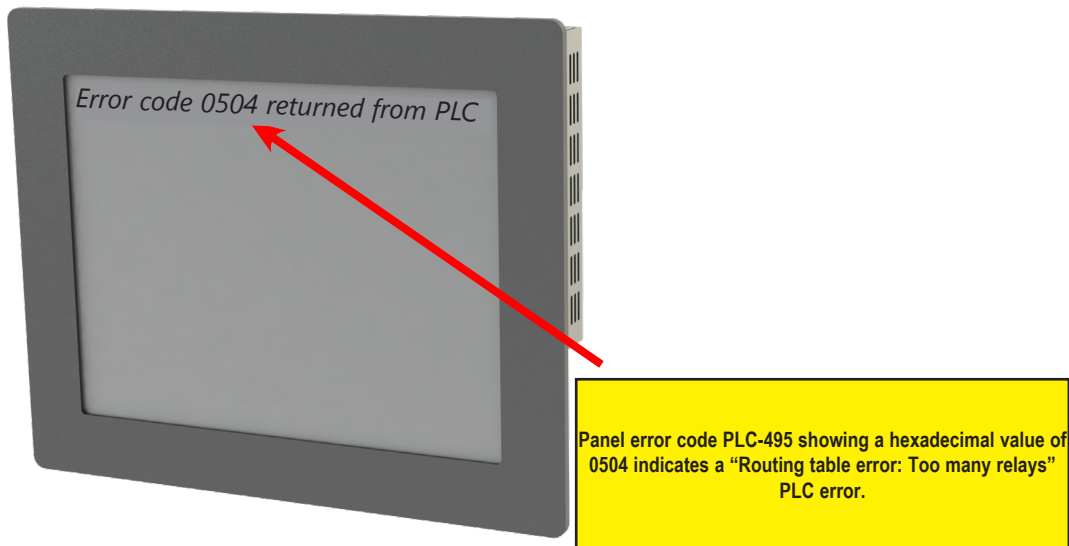

Omron CS/CJ FINS Ethernet Protocol – PLC Error Code Table

The following table lists the errors that can be generated by the Omron PLC when using the CS/CJ FINS Ethernet protocol.



NOTE: The following errors can be generated from the designated PLC, are monitored by the C-more touch panel, and displayed on the touch panel's screen as a hexadecimal value in panel error code PLC-495 message, if active. Please refer to the PLC manufacturer's documentation for additional information.

PLC Error Codes for Omron CS/CJ FINS Ethernet	
Panel Error Code PLC-495 Hex Value	Description
0103	Local Error: Send Error from lack of buffer space. Try reducing Ethernet load to the module.
0201	Destination Node Error: IP address of remote node not set correctly.
0202	Destination Node Error: No node with the specified unit address found.
0205	Destination Node Error: Packet corrupted or Response timeout. Try increasing timeout.
0301	Controller Error: Communications controller error.
0302	Controller Error: CPU Unit error. Check error LEDs on PLC. Refer to documentation for that CPU.
0304	Controller Error: Unit number error. Make sure Unit number is not used twice.
0401	Service unsupported: Undefined command.
0501	Routing table error: Destination address setting error. Routing table incorrect.
0502	Routing table error: No routing tables.
0503	Routing table error: Routing table error.
0504	Routing table error: Too many relays.
1001	Command format error: Command too long. Bad packet: check for electrical noise and grounding.
1002	Command format error: Command too short. Bad packet: check for electrical noise and grounding.
1003	Command format error: Elements/data don't match. Bad packet: check for electrical noise and grounding.
1005	Command format error: Header error. This is the error received when station # set in the command does not match the station # of the Ethernet module.
1100	Parameter error: UDP socket number bad.
1101	Parameter error: Address requested does not exist in PLC.
1103	Parameter error: Address area requested in not accessible.
220F	Status error: Duplicate Socket error.
2210	Status error: Specified socket not open.
2305	Environment Error: IP address conversion failed. Only encountered when using routing tables.
2307	Environment Error: IP address conversion set for automatic.
2503	Unit error: I/O setting error.
2505	Unit error: CPU bus error.
250A	Unit error: CPU Bus Unit error.

Siemens – Panel Error Code P499 Explanation

The PLC-499 error code is used to show any errors that are generated by the connected PLC. The PLC-499 error message includes a four-digit hexadecimal value displayed at the end of the message. This value can be looked up in the specific PLC’s error tables to determine the cause of the error. The possible PLC generated error codes for the Siemens PPI communication protocols breakdown into a four-digit hexadecimal value as shown in the following message example.

Siemens Error Code PLC-499 Message Example

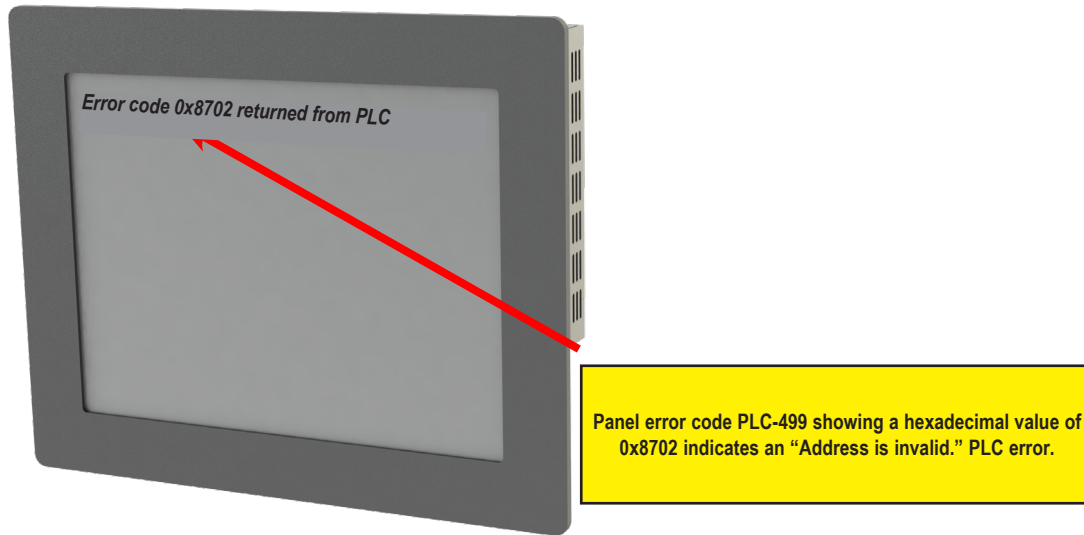

Siemens PPI Protocol – PLC Error Code Table

PLC PDU Header Errors for S7-200 PPI	
Panel Error Code PLC-499 Hex Value	Description
0x0001	Hardware Fault.
0x0003	Object access not allowed: Occurs when access to Timer and Counter data type is set to Signed Integer and not BCD.
0x0004	Context not supported.
0x0005	Address out of range: Occurs when requesting an address within a Data Block that does not exist or is out of range.
0x0006	Address out of range.
0x0007	Write Data size mismatch.
0x000A	Object does not exist: Occurs when trying to request a Data Block that does not exist.
0x8000	Function being used.
0x8001	Action is not allowed in current mode.
0x8101	Hardware fault.
0x8103	Access not allowed.
0x8104	Function not supported.
0x8105	Address invalid.
0x8106	Data Type not supported.
0x8107	Data Type is not consistent with size.
0x810A	Object does not exist.
0x8500	PDU Size is incorrect.
0x8702	Address is invalid.
0xD201	Block name syntax error.
0xD202	Error with function parameter.
0xD203	Error with block type.
0xD204	No linked block.
0xD205	Object already exists.
0xD206	Object already exists.
0xD207	Block already used in EPROM.
0xD209	Block does not exist.
0xD20E	No Block does not exist.
0xD210	Block number incorrect.

Siemens ISO over TCP Protocol – PLC Error Code Table

PLC PDU Header Errors for S7-300 CPU; S7-200, S7-400, S7-1200, S7-1500 Ethernet	
Panel Error Code PLC-499 Hex Value	Description
0x0001	Hardware Fault.
0x0003	Object access not allowed: Occurs when access to Timer and Counter data type is set to Signed Integer and not BCD.
0x0004	Context not supported.
0x0005	Address out of range: Occurs when requesting an address within a Data Block that does not exist or is out of range.
0x0006	Address out of range.
0x0007	Write Data size mismatch.
0x000A	Object does not exist: Occurs when trying to request a Data Block that does not exist.
0x8000	Function being used.
0x8001	Action is not allowed in current mode.
0x8101	Hardware fault.
0x8103	Access not allowed.
0x8104	Function not supported.
0x8105	Address invalid.
0x8106	Data Type not supported.
0x8107	Data Type is not consistent with size.
0x810A	Object does not exist.
0x8500	PDU Size is incorrect.
0x8702	Address is invalid.
0xD201	Block name syntax error.
0xD202	Error with function parameter.
0xD203	Error with block type.
0xD204	No linked block.
0xD205	Object already exists.
0xD206	Object already exists.
0xD207	Block already used in EPROM.
0xD209	Block does not exist.
0xD20E	No Block does not exist.
0xD210	Block number incorrect.

BLANK
PAGE



APPENDIX

B

TOUCH PANEL RUNTIME ERRORS

In this Section...

Introduction.....	B-2
Runtime Errors.....	B-3

Introduction

The **C-more** touch panels have diagnostics built-in to the operating system that monitor various runtime functions that will display an error message on the panel's display indicating that a particular error has occurred and what the error represents. The Error Message(s) is displayed in the upper left area of the display screen. The Runtime Errors are also logged into the panel's Error log under the Information tab in the panel's System Setup Screens. The Error Log Code, for example RTE-004, identifies the error on the System Screen - Error tab and in the error log. See Chapter 5: System Setup Screens for additional details. The tables that follow show the possible Runtime Errors.

The user can include in their touch panel project the use of this diagnostic information by using the system tag name SYS ERR ERRORCODE to control displayed screens, operator messages, etc., and also communicate error information to the PLC or controlling device. If a runtime error occurs, the SYS ERR ERRORCODE system tag will contain the numeric value shown under the Tag Code Error Value. For example, if the panel project is configured to log to USB and no USB flash drive is installed in the panel, the panel will display "RTE-004 Log buffer memory is full" and the SYS ERR ERRORCODE system tag will contain the value 2004. The value of the last runtime error detected will remain in the SYS ERR ERRORCODE.

If you have difficulty determining the cause of the error, refer to **Chapter 8: Troubleshooting** for additional help or contact our technical support group at 770-844-4200

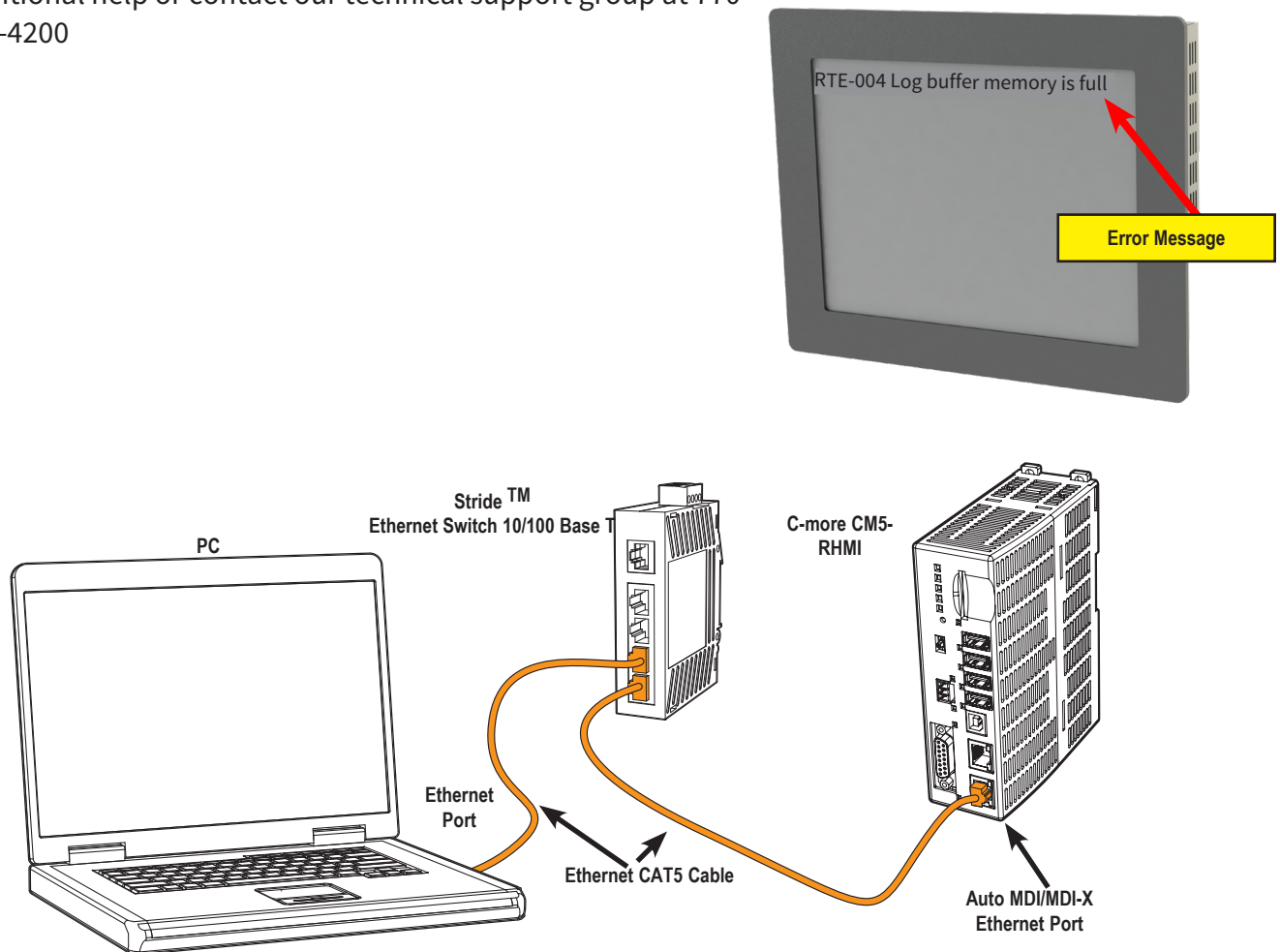

Runtime Errors

The following table includes all of the error codes and error messages that the panel will display if the listed cause is detected. All of these errors involve problems that could result with the panel communicating with the connected PLC. Be aware that not all of the panel errors are used with each type of PLC that can be connected to the panel.

No.	Error Log Code	Error Message Located at upper left of screen	Error Message Tag	Tag Error Code Value	System Screen Info > Error	Cause
Log Error						
1	RTE-001	Log Failed. Not enough Memory Space in %Device%	SYS ERR ERRORCODE	2001	MM/DD/YY HH/MM/SS Error Code RTE-001	The size of the destination memory is not large enough to store the data.
2	RTE-002	Log Failed. %Device% cannot be found	SYS ERR ERRORCODE	2002	MM/DD/YY HH/MM/SS Error Code RTE-002	No device available or the device is defective.
3	RTE-003	Log Failed. Can not write file - %file%	SYS ERR ERRORCODE	2003	MM/DD/YY HH/MM/SS Error Code RTE-003	Logging the data has failed due to a problem such as the memory write protect is enabled.
4	RTE-004	Log cache memory is full	SYS ERR ERRORCODE	2004	MM/DD/YY HH/MM/SS Error Code RTE-004	The data log buffer in the SRAM memory is full.
Screen Capture						
1	RTE-011	Capture Failed. Not enough Memory Space in %Device%	SYS ERR ERRORCODE	2011	MM/DD/YY HH/MM/SS Error Code RTE-011	The size of the destination memory is not large enough to store the data.
2	RTE-012	Capture Failed. %Device% cannot be found	SYS ERR ERRORCODE	2012	MM/DD/YY HH/MM/SS Error Code RTE-012	No device available or the device is defective.
3	RTE-013	Capture Failed. Can not write file - %file%	SYS ERR ERRORCODE	2013	MM/DD/YY HH/MM/SS Error Code RTE-013	Logging the data has failed due to a problem such as the memory write protect is enabled.
Table continued						

Runtime Errors (cont'd)

No.	Error Log Code	Error Message Located at upper left of screen	Error Message Tag	Tag Error Code Value	System Screen Info > Error	Cause
Handshake						
1	RTE-021	Handshake Timeout Error	SYS ERR ERRORCODE	2021	MM/DD/YY HH/MM/SS Error Code RTE-021	A communications timeout occurred when either a Recipe or Numeric Entry Object, in which Notification and Handshake signals are used, failed to complete the responses.
e-mail						
1	RTE-041	E-mail Connection Error %Address%	SYS ERR ERRORCODE	2041	MM/DD/YY HH/MM/SS Error Code RTE-041	An incorrect SMTP address has been entered into the Panel Network dialog screen.
2	RTE-042	Send E-mail Error %Address%	SYS ERR ERRORCODE	2042	MM/DD/YY HH/MM/SS Error Code RTE-042	An incorrect email address has been entered into the Address Book.
3	RTE-043	Email Failed: The file cannot be attached	SYS ERR ERRORCODE	2043	MM/DD/YY HH/MM/SS Error Code RTE-043	—
Send FTP						
1	RTE-051	FTP Connection Error %Address%&%ID%	SYS ERR ERRORCODE	2051	MM/DD/YY HH/MM/SS Error Code RTE-051	An incorrect FTP Service has been assigned into the Panel Network dialog screen.
2	RTE-052	Send FTP Error %Address%&%ID%	SYS ERR ERRORCODE	2052	MM/DD/YY HH/MM/SS Error Code RTE-052	Permission to write to the FTP folder has not been authorized. The FTP site may require a user ID and password.
3	RTE-053	FTP Failed: The file cannot be copied	SYS ERR ERRORCODE	2053	MM/DD/YY HH/MM/SS Error Code RTE-053	—
Receive FTP						
1	RTE-061	Receive FTP Error	SYS ERR ERRORCODE	2061	MM/DD/YY HH/MM/SS Error Code RTE-061	—
2	RTE-062	FTP Server stopped due to excessive connections from %Address%	SYS ERR ERRORCODE	2062	MM/DD/YY HH:MM:SS Error Code RTE-062	The listed IP Address has attempted unsuccessfully to connect to the FTP Server in what appears to be a Denial of Service attack.
Receive HTTP						
1	RTE-071	Receive HTTP Error	SYS ERR ERRORCODE	2071	MM/DD/YY HH/MM/SS Error Code RTE-071	—
Sound						
1	RTE-081	Sound Failed. Not enough Memory	SYS ERR ERRORCODE	2081	MM/DD/YY HH/MM/SS Error Code RTE-081	The sound file failed to play due to insufficient memory.
Table continued						

Runtime Errors (cont'd)

No.	Error Log Code	Error Message Located at upper left of screen	Error Message Tag	Tag Error Code Value	System Screen Info > Error	Cause
Conflict						
1	RTE-091	IP Address Conflict - Correct IP Address and Power Cycle	SYS ERR ERRORCODE	2091	MM/DD/YY HH/MM/SS Error Code RTE-091	Conflict of IP Address
Multiple Recipe						
1	RTE-101	Record doesn't exist	SYS ERR ERRORCODE	2101	MM/DD/YY HH/MM/SS Error Code RTE-101	The recipe file or data doesn't exist.
2	RTE-102	File cannot open	SYS ERR ERRORCODE	2102	MM/DD/YY HH/MM/SS Error Code RTE-102	The recipe file cannot be opened.
3	RTE-103	Wrong Data - Row Column	SYS ERR ERRORCODE	2103	MM/DD/YY HH/MM/SS Error Code RTE-103	Abnormality is found in the numeric character data of the recipe file.
4	RTE-104	Wrong Tag - Row Column	SYS ERR ERRORCODE	2104	MM/DD/YY HH/MM/SS Error Code RTE-104	Abnormality is found in the Tag data of the recipe file.
5	RTE-105	Recipe - Index (%Row%) error	SYS ERR ERRORCODE	2105	MM/DD/YY HH/MM/SS Error Code RTE-105	Recipe was operated by the record number outside the range.
6	RTE-106	Not enough buffer memory	SYS ERR ERRORCODE	2106	MM/DD/YY HH/MM/SS Error Code RTE-106	Memory allocation error
7	RTE-107	File cannot write	SYS ERR ERRORCODE	2107	MM/DD/YY HH/MM/SS Error Code RTE-107	There was an error trying to write the recipe file.
8	RTE-108	Wrong file format	SYS ERR ERRORCODE	2108	MM/DD/YY HH/MM/SS Error Code RTE-108	The recipe file format is incorrect.
9	RTE-109	Not enough Memory Space in %Device%	SYS ERR ERRORCODE	2109	MM/DD/YY HH/MM/SS Error Code RTE-109	Insufficient storage space on media.
Table continued						

Runtime Errors (cont'd)

No.	Error Log Code	Error Message Located at upper left of screen	Error Message Tag	Tag Error Code Value	System Screen Info > Error	Cause
Action						
1	RTE-121	Action Overflows	SYS ERR ERRORCODE	2121	MM/DD/YY HH/MM/SS Error Code RTE-121	The number of actions executed in the event exceeded the maximum number.
SD Ejection						
1	RTE-130	SD1 has been removed from the panel and the panel has stopped. To restart the panel, insert the SD1 card and press Reboot.	SYS ERR ERRORCODE	2130	MM/DD/YY HH/MM/SS Error Code RTE-130	The project is on SD1 and the SD1 was removed.
2	RTE-131	The panel has detected a Project file in SD1 and in the Panel Built-in-Flash. Only one location can contain a project. See Help File topic Project Storage/Boot Location	SYS ERR ERRORCODE	2131	MM/DD/YY HH/MM/SS Error Code RTE-130	—
SRAM Error						
1	RTE-500	SRAM Checksum Error	SYS ERR ERRORCODE	2500	MM/DD/YY HH/MM/SS Error Code RTE-500	Memory in Panel has been Corrupted by Power Loss, etc. Try cycling power to the panel and re-transfer the project to the panel, in sequential steps to attempt to resolve the error.
SRAM Error						
1	RTE-500	SRAM Checksum Error	SYS ERR ERRORCODE	2500	MM/DD/YY HH/MM/SS Error Code RTE-500	Memory in Panel has been Corrupted by Power Loss, etc. Try cycling power to the panel and re-transfer the project to the panel, in sequential steps to attempt to resolve the error.

SYSTEM SCREEN ERROR CODES



APPENDIX

C

In This Section...

<i>C-more</i> Touch Panel System Screen Error Code Table.....	C-2
---	-----

C-more Touch Panel System Screen Error Code Table

The following table provides a list of **C-more** Panel SSC (System Screen) errors that may be displayed on the panel when performing different operations in the panel system screens.

C-more Touch Panel System Screen Error Code Table		
Error Code	Error Message	Description
SSC-100	Please enter the year from %1 to %2.	Enter a valid value for the Year
SSC-101	Date is incorrect.	Enter a valid value for the Date
SSC-130	Input value is invalid. Please input all octets from the first octet to the fourth octet. The value of each octet should be 0~255.	See message on panel
SSC-131	Input value is invalid. Please input all octets from the first octet to the fourth octet. The value of each octet should be 0~255.	See message on panel
SSC-132	The combination of "Static" for "IP Address" and "Obtain DNS Server Address from DHCP" for "DNS Server" cannot be set.	Select either Static or DHCP for both IP Address and DNS server.
SSC-133	These are the same network address (%1/%2)	"Network addresses must be different for each Ethernet Port. For example: Eth Port 1 - 192.168.12.1/16 Eth Port 2 - 192.168.10.100/16 Both have Network address - 192.168.0.0 /16=Subnet Mask of 255.255.0.0"
SSC-134	Invalid IP Address.	The input IP address is a link local address (169.254 series). Choose different IP Address that is not a Link Local Network address.
SSC-135	Different Network address is used between Default Gateway and Preferred.	
SSC-136	An unexpected error has occurred. Please reopen the system screen again. (Code: %1)	
SSC-300	"%1 does not have enough free space. Please use a %2 with more space."	The backup destination device is does not have enough space. Choose another device.
SSC-301	An exception error has occurred. Unable to execute.	The folder /home/CM5/EA/WSUpdatePanel does not exist. Requires a firmware update to correct.
SSC-302	Invalid storage is selected. %1	Displayed when the backup destination is not set. Backout of screen and select destination device again or try a different device.
SSC-303	Invalid data area is selected.	Select a valid backup target
SSC-304	Another process is in progress. Please try again after a while.	Wait a few minutes. Memory is being used by another process at the moment.
SSC-305	Cannot run in safe mode.	Wait a few minutes. Memory is being used by another process at the moment. Cycle power, update firmware if possible. If problem continues, there may be a hardware defect.
SSC-306	Backup Failed.%1	Backup to device failed. Try again. If problem continues reformat the backup device or try a different device. Make sure power is not interrupted.
SSC-320	Invalid storage is selected. %1	Select a valid target device and files.
SSC-310	Backed up Firmware Support Panel: %1 Restore Panel Type: %2 Cannot restore because the panel type is not supported by the firmware.	"This error occurs when the target panel does not match the backup. For example, trying to restore a CM5-T4W project to a CM5-T10W panel. Combinations not allowed: CM5-T4W, -T7W to CM5-T10,-T12W,-T15W or -T22W CM5-T10,-T12W,-T15W or -T22W to CM5-T4W, -T7W"
SSC-311	The Restore Project is configured to boot from SD1. Please Insert SD1.	Insert SD Card into SD1 slot and try again.
SSC-312	Project version: %1 Current Panel version: %2 Cannot restore because the Project version does not match the Panel Firmware version.	The backup does not contain the firmware version, so the project file in the backup must match the panel firmware. Update the panel firmware to match the backup file version using the CM5-PGMSW software or backup the file again, making sure to select to backup both firmware and project.
SSC-313	Cannot restore because the project size exceeds the %1 memory available.	Clear panel memory and try again. Make sure the panel you are restoring to is the correct model with the same amount of source panel memory.
SSC-314	"An exception error has occurred. Unable to execute."	The folder /home/CM5/EA/WSUpdatePanel does not exist. Requires a firmware update to correct.

C-more Touch Panel System Screen Error Code Table continued on the next page

C-more Touch Panel System Screen Error Code Table (con't)

C-more Touch Panel System Screen Error Code Table		
Error Code	Error Message	Description
SSC-315	Invalid storage is selected. %1	Displayed when the restore destination is not set. Backout of screen and select destination device again or try a different device.
SSC-316	Invalid data area is selected.	Select a valid restore device
SSC-317	Another process is in progress. Please try again after a while.	Wait a few minutes. Memory is being used by another process at the moment.
SSC-318	Cannot run in safe mode.	Wait a few minutes. Memory is being used by another process at the moment. Cycle power, update firmware if possible. If problem continues, there may be a hardware defect.
SSC-319	Restore Failed. %1	Restoration from device failed. Try again. If problem continues try a different device. Make sure power is not interrupted.
SSC-321	"Restoration is not possible because the Panel Type is different. Restore Project Type: %1 Current Panel Type: %2	Backup file does not match the panel being restored to. Choose the correct panel model to restore to.

BLANK
PAGE

SECURITY CONSIDERATIONS FOR CONTROL SYSTEMS NETWORKS



APPENDIX

D

In this Section...

Security Considerations for Control Systems Networks D-2

Security Considerations for Control Systems Networks

Manufacturers are realizing that to stay competitive, their Automation and Control Systems need to be more integrated within their plant. The systems often need to be integrated with upstream Enterprise Data Systems, and even further integrated to allow information to be accessible across multiple plants, or even through the Internet. This convergence of the IT world with the Automation World creates challenges in maintaining secure systems and protecting your investments in processes, personnel, data and intellectual property.

While Automation Networks and Systems have built-in password protection schemes, this is only one very small step in securing your systems. Automation Control System Networks need to incorporate data protection and security measures that are at least as robust as a typical business computer system. We recommend that users of PLCs, HMI products and SCADA systems perform your own network security analysis to determine the proper level of security required for you application. However, the Department of Homeland Security's National Cybersecurity and Communications Integration Center (NCCIC) and Industrial Control Systems Cyber Emergency Response Team (ICS-CERT) has provided direction related to network security and safety under an approach described as "Defense in Depth", which is published at [https://ics-cert.us-cert.gov/sites/default/files/recommended_practices/NCCIC ICS-CERT Defense in Depth 2016 S508C.pdf](https://ics-cert.us-cert.gov/sites/default/files/recommended_practices/NCCIC%20ICS-CERT%20Defense%20in%20Depth%202016%20S508C.pdf)

This comprehensive security strategy involves physical protection methods, as well as process and policy methods. This approach creates multiple layers and levels of security for industrial automation systems. Such safeguards include the location of control system networks behind firewalls, their isolation from business networks, the use of intrusion detection systems, and the use of secure methods for remote access such as Virtual Private Networks (VPNs). Further, users should minimize network exposure for all control system devices and such control systems and these systems should not directly face the internet. Following these procedures should significantly reduce your risks both from external sources as well as internal sources, and provide a more secure system.

It is the user's responsibility to protect such systems, just as you would protect your computer and business systems. AutomationDirect recommends using one or more of these resources in putting together a secure system:

- ICS-CERT's Control Systems recommended practices at the following web address: <https://ics-cert.us-cert.gov/Recommended-Practices>
- Special Publication 800-82 of the National Institute of Standards and Technology – Guide to Industrial Control Systems (ICS) Security: <https://csrc.nist.gov/publications/detail/sp/800-82/rev-2/final>
- ISA99, Industrial Automation and Control Systems Security <https://www.isa.org/standards-and-publications/isa-standards/isa-standards-committees/isa99> (please note this is a summary and these standards have to be purchased from ISA)

The above set of resources provides a comprehensive approach to securing a control system network and reducing risk and exposure from security breaches. Given the nature of any system that accesses the internet, it is incumbent upon each user to assess the needs and requirements of their application and take steps to mitigate the particular security risks inherent in their control system.



