

REPLACEMENT PARTS





CHAPTER

9

In This Chapter...

Replacement Parts Overview	9-2
3-wire Communications Terminal Block – EA9-3TB.....	9-3
DC Panel Power Connector Replacement – C0-4TB.....	9-3

Replacement Parts Overview

Part Number		Description
EA9-3TB		<p>C-more pluggable terminal block, replacement, 3-pole. Package of 2. For use with 3-wire RS485 communications port on C-more EA9 series panels.</p>
C0-4TB		<p>CLICK terminal blocks, replacement, 4-pole. Package of 2. For use with CLICK PLCs and C-more CM5-RHMI.</p>

3-wire Communications Terminal Block – EA9-3TB

C-more CM5 series 3-wire communications terminal block replacement. One (1) terminal block is supplied with each HMI. Two (2) connectors are supplied when ordered as a replacement part.

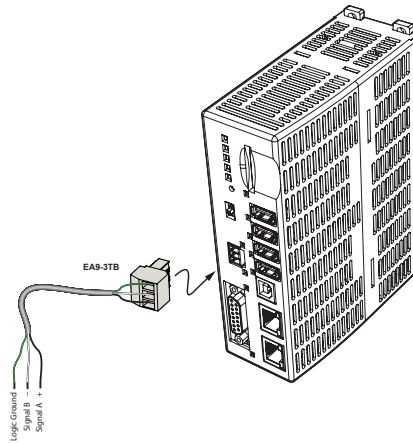

Tightening Torque	
Cable torque	Minimum 1.95 lb-in (0.22 Nm)



NOTE: Use 60/75 °C copper conductors only, 16-24 AWG

DC Power Connector Replacement – C0-4TB

CM5-RHMI 4-position DC power connector terminal block replacement. One (1) DC Power Connector is supplied with each HMI. Two (2) connectors are supplied when ordered as a replacement part.

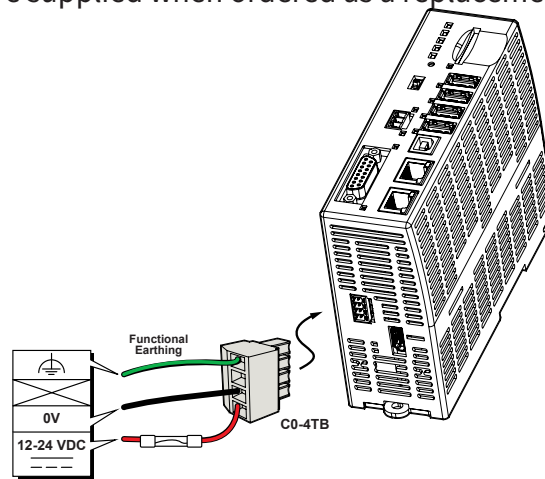

Tightening Torque	
Power supply cable torque	35.4 oz-in (20.25Nm)



NOTE: Use 60/75 °C copper conductors only, 16-24 AWG

BLANK
PAGE