

INSTALLATION AND WIRING



CHAPTER

4

In This Chapter...

Safety Guidelines	4-2
Plan for Safety.....	4-2
Introduction	4-3
Mounting	4-4
DIN Rail Mounting.....	4-4
Panel Mounting.....	4-4
Mounting Clearances.....	4-5
Wiring Guidelines	4-6
Agency Approvals.....	4-6
Providing Power to the HMI	4-7
C-more LED Status Indicators.....	4-8
Reset Button	4-9
RUN/STOP switch	4-9
User Defined LED	4-9
CM5-RHMI Beep.....	4-9

Safety Guidelines



NOTE: *Products with CE marks perform their required functions safely and adhere to relevant standards as specified by CE directives provided they are used according to their intended purpose and that the instructions in this manual are adhered to. The protection provided by the equipment may be impaired if this equipment is used in a manner not specified in this manual. A listing of our international affiliates is available on our website: <http://www.automationdirect.com>*



WARNING: Providing a safe operating environment for personnel and equipment is your responsibility and should be your primary goal during system planning and installation. Automation systems can fail and may result in situations that can cause serious injury to personnel or damage to equipment. Do not rely on the automation system alone to provide a safe operating environment. You should use external electromechanical devices, such as relays or limit switches, that are independent of the PLC application to provide protection for any part of the system that may cause personal injury or damage. Every automation application is different, so there may be special requirements for your particular application. Make sure you follow all national, state, and local government requirements for the proper installation and use of your equipment.

Plan for Safety

The best way to provide a safe operating environment is to make personnel and equipment safety part of the planning process. You should examine every aspect of the system to determine which areas are critical to operator or machine safety. If you are not familiar with control system installation practices, or your company does not have established installation guidelines, you should obtain additional information from the following sources.

- NEMA — The National Electrical Manufacturers Association, located in Washington, D.C. publishes many different documents that discuss standards for industrial control systems. You can order these publications directly from NEMA. Some of these include:
 - ICS 1, General Standards for Industrial Control and Systems
 - ICS 3, Industrial Systems
 - ICS 6, Enclosures for Industrial Control Systems
- NEC — The National Electrical Code provides regulations concerning the installation and use of various types of electrical equipment. Copies of the NEC Handbook can often be obtained from your local electrical equipment distributor or your local library.
- Local and State Agencies — many local governments and state governments have additional requirements above and beyond those described in the NEC Handbook. Check with your local Electrical Inspector or Fire Marshall office for information.

Introduction

The installation and wiring of the **C-more**® CM5-RHMI requires selecting an appropriate location for the HMI in the control cabinet that it will be mounted in, securing the unit to the DIN Rail or mounting it to the back panel of the enclosure with screws, and connecting the appropriate power source to the HMI.

This chapter covers the proper mounting of the CM5-RHMI and connecting power. Once power is applied to the unit, the user will want to read Chapter 5, System Setup Screens, in order to set the internal time and date for the unit, become familiar with the HMI test features, and check memory options.

Mounting

DIN Rail Mounting

CM5-RHMI can be mounted vertically on a standard 35mm x 7.5mm height DIN rail (Standard: CENELEC EN50022).

1. Pull the bottom retaining tab of the CM5-RHMI down.
2. Position the CM5-RHMI on the DIN rail.
3. Push the retaining tab up until it clicks to secure the CM5-RHMI on the DIN rail.

Panel Mounting

CM5-RHMI can be mounted vertically on a panel using the tabs located on the back of the unit.

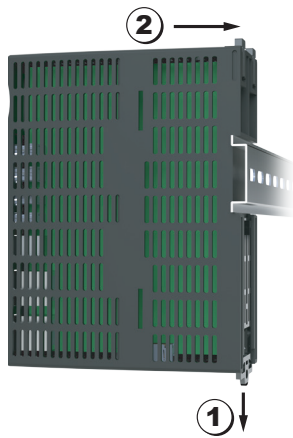

1. Fully extend the three mounting tabs located on the top and bottom of the unit.



2. Secure to a panel using three #8 standard or M4 metric screws and appropriate hardware.

Mounting Clearances

The following drawing shows the mounting clearances for the **C-more** RHMI. There should be a minimum of 2 inches of space on top and sides and 3 inches on the bottom from the nearest object or obstruction. There should also be a minimum of 1.75 inches of space in front of the unit to allow for the bend radius of any cables attached.

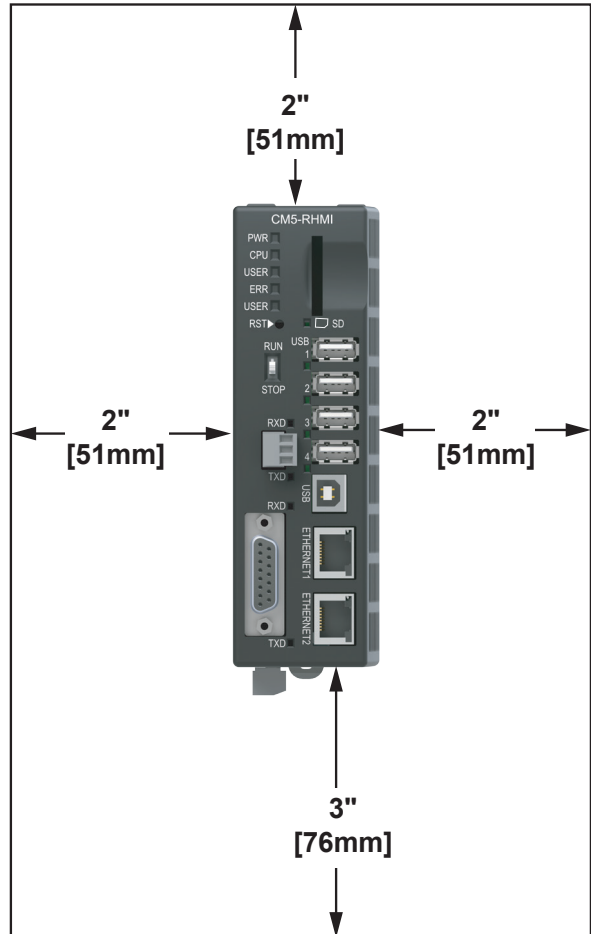
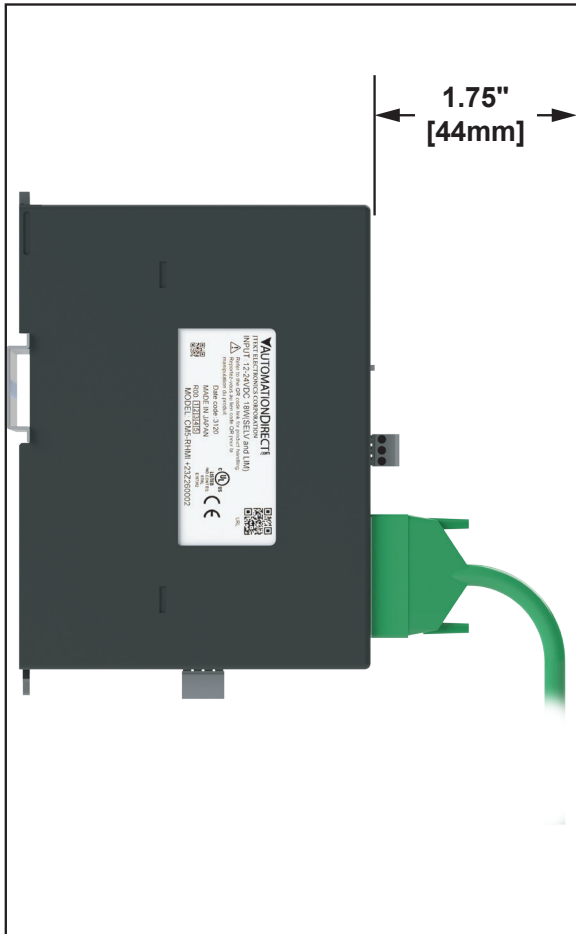

Wiring Guidelines



WARNING: To minimize the risk of potential safety problems, you should follow all applicable local and national codes that regulate the installation and operation of your equipment. These codes vary from area to area and it is your responsibility to determine which codes should be followed, and to verify that the equipment, installation, and operation are in compliance with the latest revision of these codes.

Equipment damage or serious injury to personnel can result from the failure to follow all applicable codes and standards. We do not guarantee the products described in this publication are suitable for your particular application, nor do we assume any responsibility for your product design, installation, or operation.

If you have any questions concerning the installation or operation of this equipment, or if you need additional information, please call technical support at 1-800-633-0405 or 770-844-4200.

This publication is based on information that was available at the time it was printed. At Automationdirect.com® we constantly strive to improve our products and services, so we reserve the right to make changes to the products and/or publications at any time without notice and without obligation. This publication may also discuss features that may not be available in certain revisions of the product.

Agency Approvals

Some applications require agency approvals for particular components. **C-more** agency approvals are listed below:

- UL (Underwriters' Laboratories, Inc.)
- cUL (Canadian Underwriters' Laboratories, Inc.)
- CE (European Economic Union)

Wiring Guidelines (cont'd)

Providing Power to the HMI

- **Connect a dedicated** 12-24 VDC Class 2 power supply to the DC connector on the front of the **C-more** CM5-RHMI, include wiring the ground terminal to a proper equipment ground
- **Then** turn on the power **source** and check the LED status indicators on the front of the **C-more** CM5-RHMI for proper indication (see next page)



NOTE: A dedicated power supply is recommended. If the power supply also feeds inductive loads such as solenoids or relays, the transients caused by these loads can affect the operation of the unit or damage HMI components.

DC Power Wiring

Recommended Fuse	
Rating	ADC part number
5 A	MDL-5

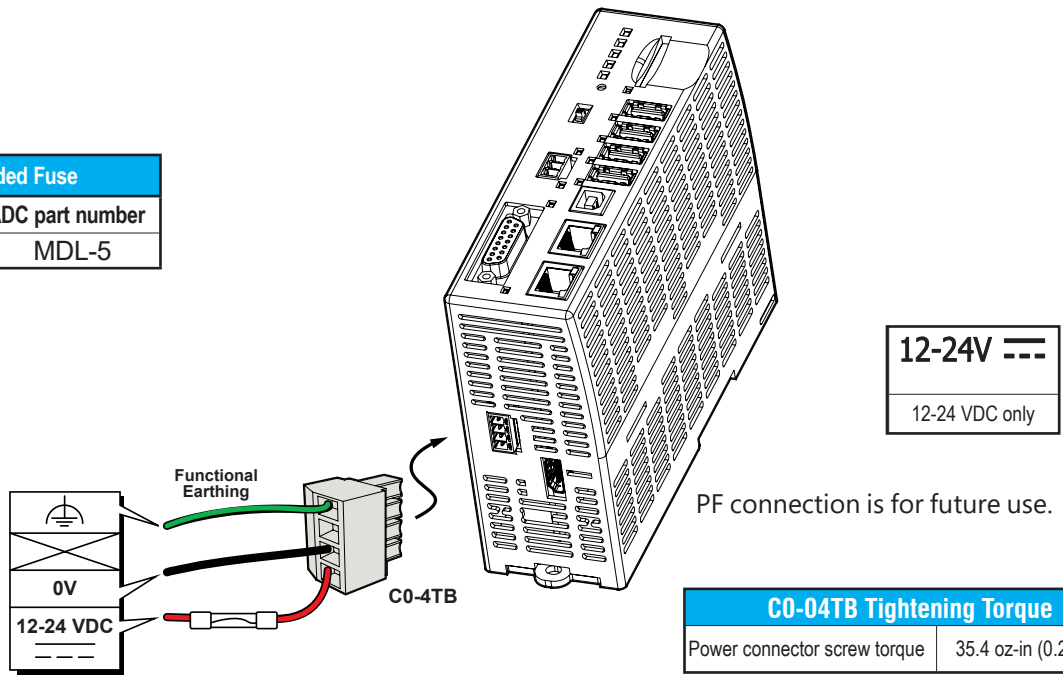

C0-04TB Tightening Torque	
Power connector screw torque	35.4 oz-in (0.25 Nm)



Warning: Use 60/75°C copper conductors only.

C-more LED Status Indicators

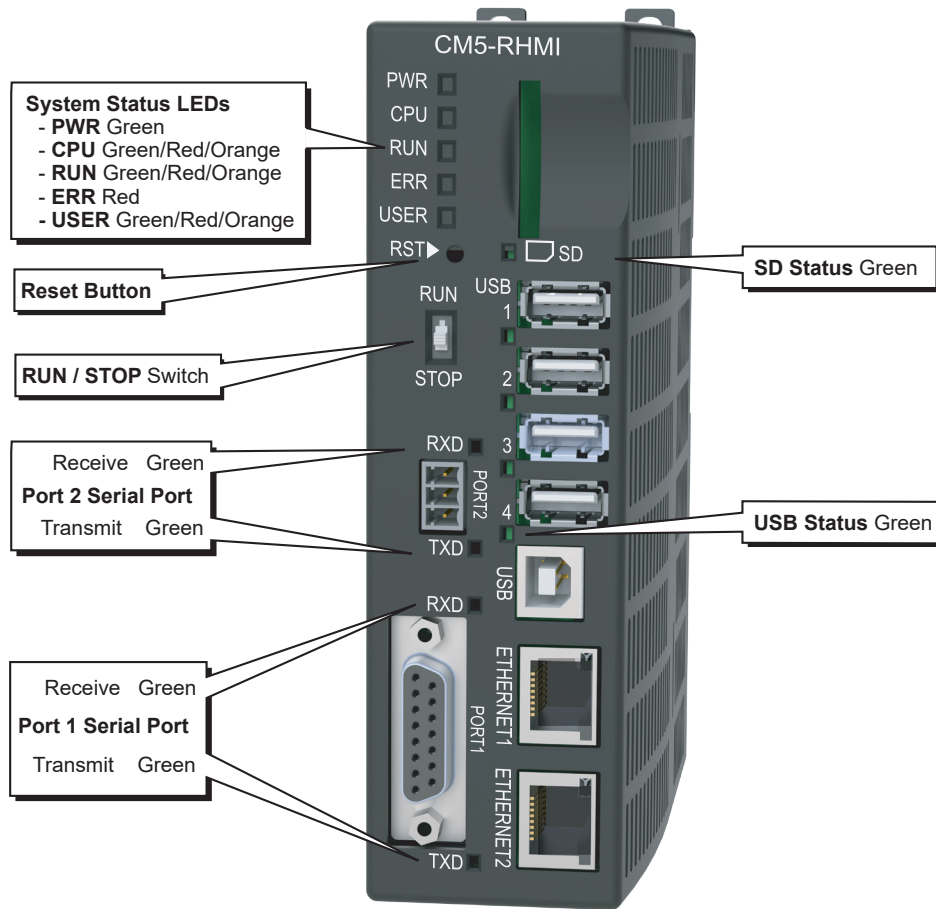

System Status LEDs				
State	LED	CPU	RUN	ERR
Loading Project		–	Blinking Green (0.2s)	–
Loading OS		Blinking Green (0.5s)	–	OFF
CPU Running Normally		Green	–	OFF
Project Loaded and Running		–	Green	–
No User Project		–	Orange	–
Reset to Factory Default		Blinking Green (0.5s)	Blinking Green (0.5s)	Blinking Red (0.5s)
System Screen		–	OFF	–
Password Required		–	Blinking Orange (0.5s)	Blinking Red (0.5s)
Errors	Power Loss Detection	Blinking Orange (0.2s)	–	–
	Memory Error	Red	OFF	Red
	OS Error	Blinking Orange (0.5s)	OFF	Red
	No Log Storage Found	–	Blinking Orange (0.5s)	Blinking Red (0.5s)
	General Error*	–	Red	Blinking Red (0.5s)
	Warning*	–	Blinking Orange (0.5s)	Blinking Red (0.5s)
	Safe Mode	Orange	OFF	Red

*Note - See Chapter 8 — Troubleshooting for General Error and Warning explanations.

Reset Button

Reset Button		
Push Action	Behavior	Note
Push for <15 seconds	Reboot the CM5-RHMI	—
Push for >15 seconds	Reset to factory default	The project is cleared and all settings are initialized.
Hold down the button and power on the CM5-RHMI	Safe Mode	The Error LED will be RED and the CPU LED will blink ORANGE. See “No System Found” in Chapter 8 - Troubleshooting

RUN/STOP switch

RUN / STOP Switch		
Position	Behavior	Note
RUN	Project will run if present and the RUN LED will be green	If no project is loaded in the HMI, the message “No Program Found” will be displayed. The RUN LED will blink orange.
STOP	The project and any logging stops and the System Screen is displayed.	If a password has been set up for the System Screen, the RUN LED will blink orange.
Power on the CM5-RHMI while in the STOP position	After the project is loaded into memory the System Screen is displayed	A System Screen password is ignored.

User Defined LED

The user defined LED on the CM5-RHMI can be controlled from the project to illuminate red, green or orange. It can also be configured to blink these colors. Refer to the online help file provided with the programming software for details.

CM5-RHMI Beep

Beep Functions	
Function	Beep Pattern
Boot	1-long, 2-short
Boot Error*	3-long
HDMI Connected	3-short
Reset to Factory Defaults	14 short beeps progressively closer together followed by 1-long beep.
Blink Screen	5-long
<p>*Boot Errors</p> <ul style="list-style-type: none"> Multiple Projects Write Protected SD Card No Log Storage Found Password Protected 	

BLANK
PAGE