

C2-08DR-6C OPTION SLOT MODULE

- 4 discrete DC sinking/sourcing inputs
- 4 discrete relay outputs
- 4 analog current inputs
- 2 analog current outputs

General Specifications	
Operating Temperature	32°F to 131°F [0°C to 55°C]
Storage Temperature	-4°F to 158°F [-20°C to 70°C]
Ambient Humidity	30% to 95% relative humidity (non-condensing)
Altitude	Up to 2,000m
Environmental Air	No corrosive gases Pollution Degree 2 (UL840)
Environment	For Indoor Use Only
Vibration	5-9Hz: 3.5 mm amplitude; 9-150Hz: 1.0 G 10 sweep cycles per axis on each of 3 mutually perpendicular axes.
Shock	15G peak, 11ms duration, 3 shocks in each direction per axis, on 3 mutually perpendicular axes.
Weight	58g
Bus Power Required	Max 100mA (all points ON)
Agency Approvals	UL61010 (File No. E157382); CE (EN61131-2); CUL Canadian C22.2
Other	RoHS 2011/65/EU Amendment (EU)2015/863

Please read and understand the information in these installation instructions prior to installation, operation, or servicing this equipment. This module is intended to be used with a CLICK PLUS CPU. Ensure the CPU is installed in accordance with its installation and safety instructions.

PLEASE REVIEW SAFETY WARNINGS ON PAGE 2!

DISCRETE I/O SPECIFICATIONS

Discrete Input Specifications	
Inputs per Module	4 (Source/Sink)
Nominal Voltage	24.0 VDC
Input Voltage Range	21.6–26.4 VDC
Input Current	6.5 mA @ 24VDC, typical
Max. Input Current	7mA @ 26.4 VDC
Input Impedance	3.9 kΩ @ 24VDC
ON Voltage Level	> 19.0 VDC
OFF Voltage Level	< 2.0 VDC
Minimum ON Current	4.5 mA
Maximum OFF Current	0.5 mA
OFF to ON Response	3μs typical, 5μs maximum
ON to OFF Response	1μs typical, 5μs maximum
Input Filter	1ms unit (set from 1 to 99 ms)*
Status Indicators	4 Green LEDs
Commons	1 (4 points/common)

* Set from CLICK Tool.

Discrete Output Specifications	
Outputs per Module	4
Operating Voltage Range	6–27VDC, 6–240VAC (47–63Hz)
Output Voltage Range	5–30VDC, 5–264VAC (47–63Hz)
Output Type	Relay, Form A(SPST)
Max. Output Current	1A/point, C2: 4A/common
Min. Load Current	5mA @ 5VDC
Max. Inrush Current	3A for 10ms
OFF to ON Response	< 15ms
ON to OFF Response	< 15ms
Status Indicators	4 Red LEDs
Commons	1 (4 points/common)

Technical Specs, continued

ANALOG I/O

Analog Input Specifications	
Number of Channels	4
Input Type	Current
Input Range	4–20mA
Resolution	12 bit
Conversion Time	50ms
Input Impedance	125Ω
Input Stability	±2 LSB, maximum
Full-scale Calibration Error	±2%, maximum
Offset Calibration Error	±0.1 mA, maximum
Accuracy vs Temperature Error	±100ppm/°C, maximum
Largest Instant Deviation During Noise Test	±20% of full scale

Analog Output Specifications	
Number of Channels	2
Output Type	Current
Output Range	4–20mA
Resolution	12 bit
Conversion Time	2.5 ms
Load Impedance	250Ω typical (200–800Ω)
Loop Power Supply	24VDC typical (21.6–26.4 VDC)
Full-scale Calibration Error	±2%, maximum
Offset Calibration Error	±0.1 mA, maximum
Accuracy vs Temperature Error	±120ppm/°C, maximum
Largest Instant Deviation During Noise Test	±20% of full scale

Safety Warnings

Please follow these instructions for personal and operational safety.

WARNING Assumes that incorrect handling may cause hazardous conditions, resulting in severe injury or death.

CAUTION Assumes that incorrect handling may cause hazardous conditions, resulting in medium or slight injury, or may cause equipment damage.

WARNING

- Don't use this equipment in a flammable or explosive environment in order to avoid accidental injury or fire.
- You should use external electromechanical devices that are independent of the PLC (Programmable Logic Controller) system to provide protection for any part of the system; otherwise malfunction or output failures may result in a hazardous accident.
- 24VDC power is required from a secondary circuit or a specific power supply unit only.
- Ensure the Ground Terminal of the Power Supply (C0-00AC/ C0-01AC) for the CLICK PLUS CPU is connected to Earth Ground to avoid electric shock or equipment damage during a short circuit.
- Don't operate the equipment with a nonconforming external power supply to avoid electric shock, equipment damage or fire.
- Don't intentionally fault the wiring; this may cause equipment damage or fire.
- To avoid electric shock or malfunctions which might result in an accident, don't touch any terminal while the PLC power is on.
- Don't put metals (e.g. screwdriver) into vent holes, or drop trash or foreign objects (e.g. wire cut-offs) into the device, in order to avoid electric shock or equipment damage.
- If the equipment is used in a manner not specified by the manufacturer, the protection provided by the equipment may be invalidated.

CAUTION

- For use in Pollution Degree 2 Environment. Use and store the equipment in an environment described in the specifications (regarding temperature, humidity, vibrations, shock, etc.) in order to avoid equipment damage or fire.
- Ensure all wiring has strain reliefs in order to avoid damage to insulation that might result in electric shock or fire.
- Ensure secondary external power circuits are only live after PLC control program is started; otherwise a malfunction or output failure may result in a hazardous accident.
- Don't block the vent holes. This may cause an increase of internal temperature resulting in equipment damage or fire.
- Don't disassemble or modify equipment so as to avoid electric shock, equipment damage, or fire.
- Cut off all phases of the external power source before maintenance work, thus avoiding electric shock or equipment damage.

Hardware Installation

CAUTION Discharge static electricity before installation or wiring to avoid electric equipment damage.

CAUTION Cut off all phases of the power source externally and wait **5 seconds** before installing or removing the Option Slot Module of a running system.

INSTALL OR REMOVE THE OPTION SLOT MODULE

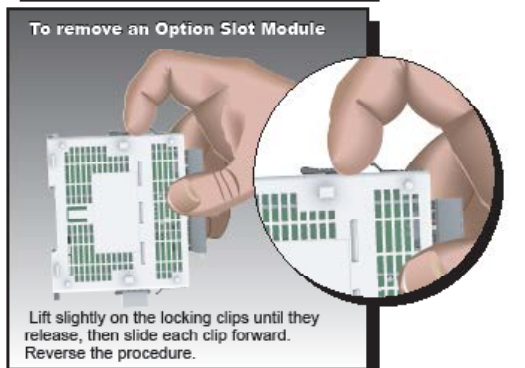
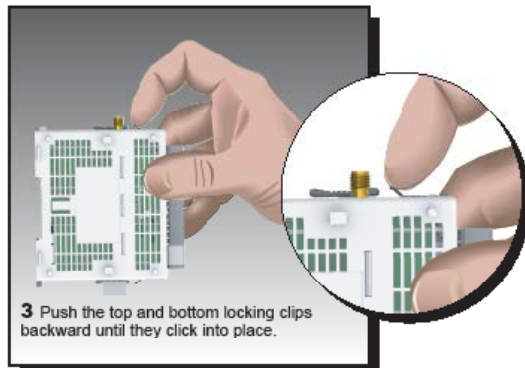
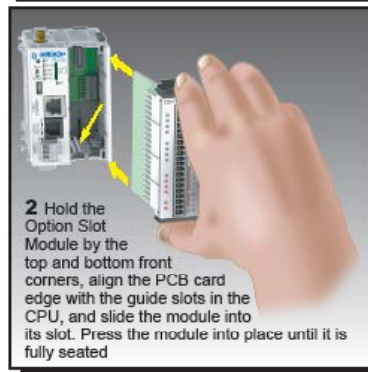

WIRING

16–28 AWG wiring is supported. We recommend using crimping ferrules on all wire terminations for a more secure connection. The following crimping ferrules are recommended for the I/O terminals.

Company	Type	Model No.	Compliant Wire
AutomationDirect	Ferrule	V30AE000009 V30AE000041	0.2–0.5 mm ² (22–26AWG)

* Rated torque is 0.22 to 0.25 N·m.
Take care not to contact adjacent terminal.

Terminal Block Specifications	
Connector Type	Pluggable Terminal Block
Number of Pins	20
Pitch	3.50 mm
Wire Size Range	16–28 AWG
Stripping Length	7.0 mm
Wire Specification	Lead-free, heat resistant, polyvinyl chloride insulated copper wire, rated over 80°C
Screw Thread	M2.0
Tightening Torque	2.0–2.2 inch-lb [0.22–0.25 N·m]

WIRING DIAGRAM

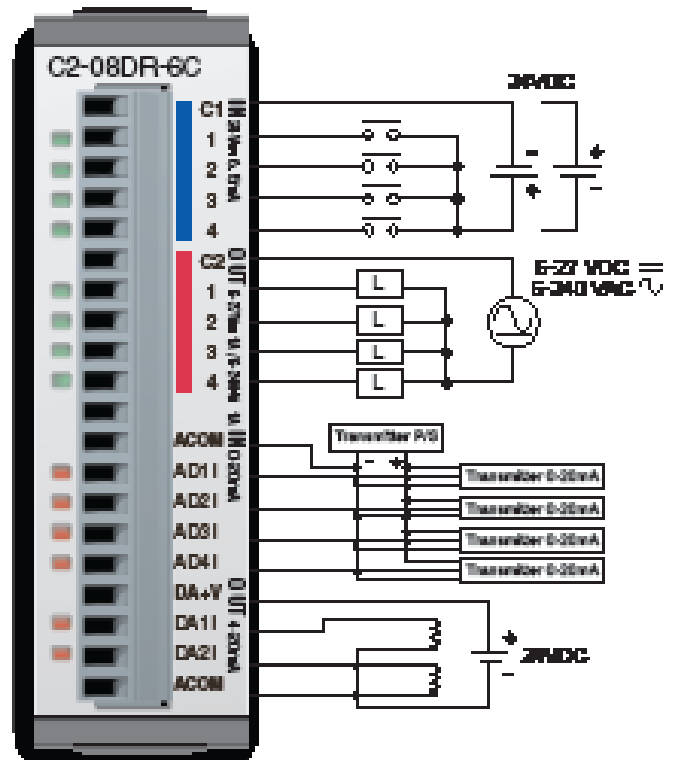

Hardware Installation, continued

EQUIVALENT CIRCUITS

Equivalent Discrete Input Circuit

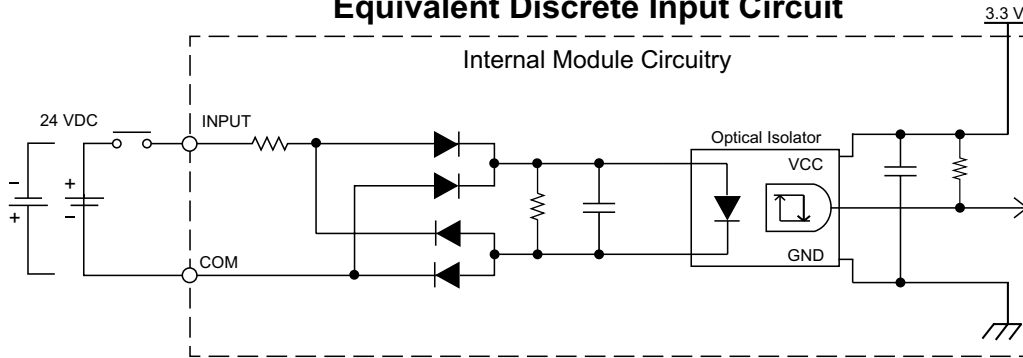

Equivalent Discrete Output Circuit

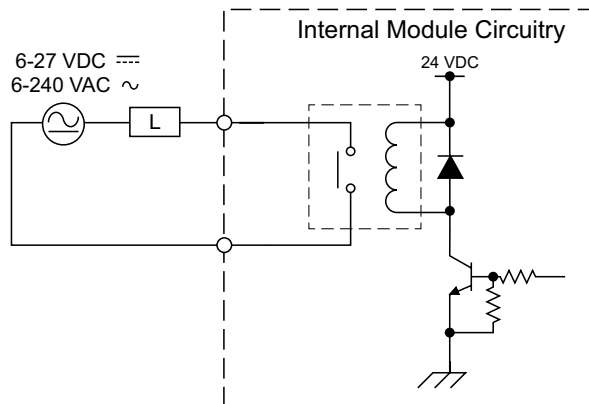

Analog Current Input Circuit

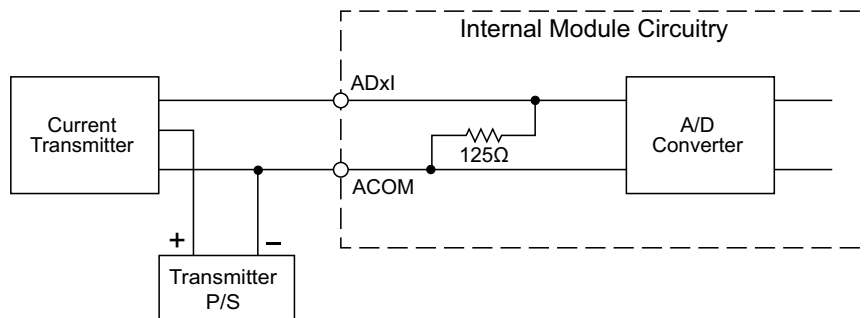

Hardware Installation, continued

EQUIVALENT CIRCUITS, CONTINUED

Analog Current Output Circuit

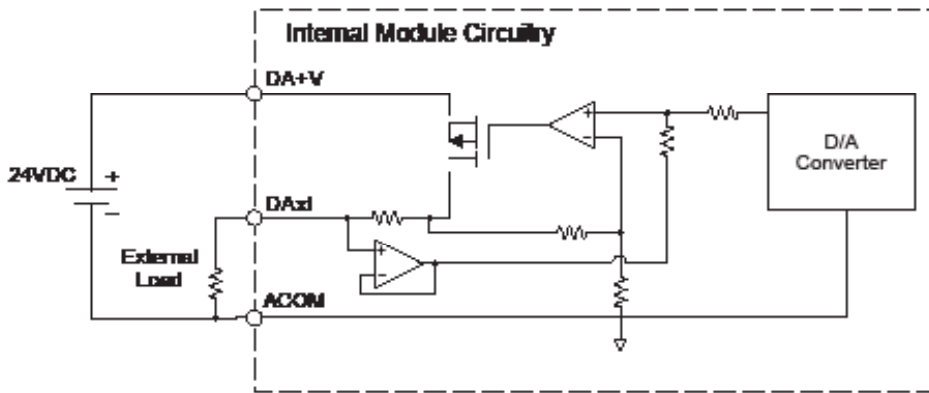

DERATING CHARTS

Discrete Input Temperature Derating Chart

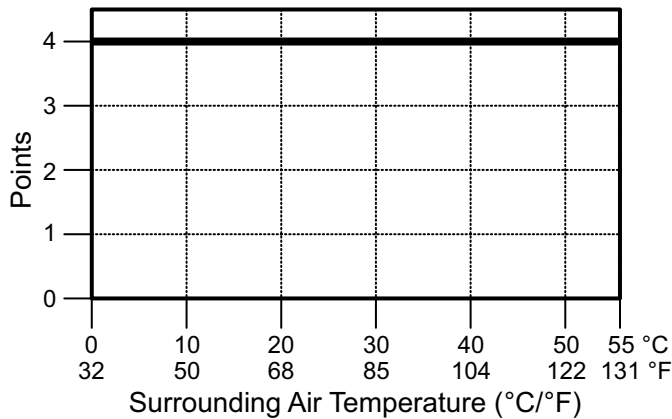

Discrete Output Temperature Derating Chart

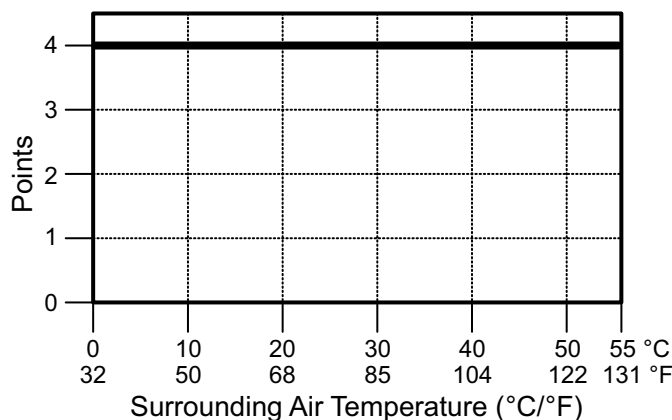

Symbols listed on the equipment are shown below.

Name	Description	Symbol
DC	DC power supply	IEC60417 No. 5031
CAUTION	<ul style="list-style-type: none"> Refer to QR code link for product handling Use Copper Conductor Only 	ISO 7000 No.0434B

INSULATION REQUIREMENTS FOR IEC/UL 61010-1 AND 61010-2-201 (SECTIONS 6.5 AND 6.7)

Input to Output Insulation

Basic insulation is provided between the Relay Output and the closest Input terminal. When connecting the Relay Output to a circuit that exceeds 100VAC (141VDC) more than the closest input circuit an additional basic insulation layer must be added to the input circuit.

Additional Basic Insulation Examples

- Supplementary Insulation: Interposing relay, additional insulating material,...
- (sec. 6.5.3)
- Automatic Disconnection of the Supply: Properly sized breaker (sec. 6.5.5)
- Current or Voltage Limiting device: Properly sized fuse (sec. 6.5.6)

Basic insulation requires a clearance distance of 1.5 mm or more, a creepage distance of 2.5 mm or more, and dielectric voltage withstand of 1500Vrms.

DC input	Internal circuit
Relay output	
Analog input Analog output	

- : No insulation
- - - : Basic insulation
- : Reinforced insulation



For additional technical support or questions, call our Technical Support team at 1-800-633-0405 or 770-844-4200.