



JEFFERSON ELECTRIC, INC.

Buck-Boost Transformer Application Manual

Revised on February 15, 2012

Table of Contents

I.	Introduction.....	2
II.	Choosing the Proper Transformer.....	2
III.	Rapid Selector Charts	4
	Single Phase Chart	4
	Open Delta Chart	6
	Wye Chart	7
IV.	Connection Instructions and Diagrams.....	9
	Single Phase	9
	3 Phase Wye.....	11
	3 Phase Open Delta.....	15
V.	Typical Questions	20
VI.	Misapplications.....	21

I. Introduction

Jefferson Electric Buck-Boost transformers are low voltage isolation transformers that can be connected in an auto-transformer arrangement to provide a convenient and economical way to raise or lower single and three-phase voltages from 5-20%. The auto-transformer arrangement allows smaller and less expensive Buck-Boost transformers to supply large power loads.

This application manual provides the information to properly select and install a Buck-Boost transformer. Sections of this manual include the answers to typical questions, common misapplications and the wiring diagrams for most applications.

Important notes regarding Buck-Boost Transformers;

- Buck-Boost transformers do not compensate for fluctuating voltages, they will always increase or decrease the voltage by a constant percentage of the source voltage.
- Buck-Boost transformers do not provide electrical isolation from the source voltage. If electrical isolation is required a separate isolation transformer must be used.
- When using transformers connected per these wiring diagrams, check local electrical code requirements regarding the use of auto-transformers to ensure compliance.

II. Choosing the Proper Transformer

You will need the following information to select the appropriate transformer for your application;

- ◆ Phase requirement, single phase or three phase
- ◆ Three phase Load wiring, 3-wire or 4-wire
- ◆ Source voltage
- ◆ Load voltage
- ◆ Load KVA or Amperage

Step 1: What is the load: Single-Phase or Three-Phase?

- ◆ If single-phase: Go to Single-Phase Chart.
- ◆ If three-phase: Is the load 3-wire or 4-wire?
 - Three wire: You can use the Open Delta Chart or the Wye Chart.
 - Four wire: You must make sure you have a wye source, if not see misapplication M3, otherwise go to the Wye Chart.

Step 2: What is the source and load voltage?

- ◆ -Are you stepping up or stepping down the voltage?
 - Stepping up: Go to the LV column in the charts and find your source voltage.
 - Stepping down: Go to the HV column in the charts and find your source voltage.
- ◆ After locating the source voltage in the charts, find your load voltage.
 - Stepping up: Go to the HV column in the charts and find your load voltage.
 - Stepping down: Go to the LV column in the charts and find your load voltage.
- ◆ Please note that you might not find the exact voltage because of the fixed change of the buck-boost transformer. So locate the closest voltage to your load voltage and determine if this is acceptable for your application. Note the Catalog number shown, (e.g. 416-12xx)

Step 3: What is the amperage required by the load or the KVA of the load?

From the voltages that you have chosen, go across the chart until you find a maximum current greater than your required current or a maximum KVA greater than your maximum load KVA.

Step 4: From this current or KVA you will complete the catalog number for the buck-boost transformer required.

Go up the chart to the top of the column and you will find two numbers (e.g. 11, 21, 31, etc). Place these two numbers at the end of the catalog number chosen above in place of the xx, (e.g. 416-12**31**). The catalog number is completed by adding a -000 to the end. (e.g. 416-1231-**000**).

Step 5: Order the number of units that are required, located in the title of the charts (1 for single-phase, 2 for open delta and 3 for wye configurations).

Step 6: Note the diagram number at the end of the row of the selected voltages. Connect the transformers per the diagram listed for the transformers you have chosen. See Section IV for wiring diagrams.

III. Rapid Selector Charts

Single Phase Chart (requires 1 transformer)

Low Voltage (LV)	High Voltage (HV)	Catalog Number	Load Required	01	11	21	31	41	51	61	71	81	91	New Diagram #	Old Diagram #
95	120	416-12xx	KVA Amperes	0.37 3.95	0.56 5.93	0.94 9.89	1.8 19.7	2.8 29.6	3.7 39.5	5.6 59.3	7.5 79.1	11.2 118	18.8 197	2	56-B
100	120	416-11xx	KVA Amperes	0.50 5.0	0.75 7.5	1.25 12.5	2.5 25.0	3.7 37.0	5.0 50.0	7.5 75.0	10.0 100	15.0 150	25.0 250	2	56-B
106	120	416-12xx	KVA Amperes	0.75 7.07	1.12 10.5	1.87 17.6	3.7 34.9	5.6 52.8	7.5 70.7	11.2 105	15.0 141	22.5 212	37.0 349	1	56-A
109	120	416-11xx	KVA Amperes	1.0 9.17	1.5 13.7	2.5 22.9	5.0 45.8	7.5 68.8	10.0 91.7	15.0 137	20.0 183	30.0 275	50.0 458	1	56-A
120	132	416-11xx	KVA Amperes	1.10 9.17	1.65 13.7	2.75 22.9	5.5 45.8	8.2 68.8	11.0 91.7	16.5 137	22.0 183	33.0 275	55.0 458	1	56-A
120	136	416-12xx	KVA Amperes	0.85 7.08	1.27 10.5	2.12 17.6	4.2 35.0	6.3 52.5	8.5 70.8	12.7 105	17.0 141	25.5 212	42.0 350	1	56-A
120	144	416-11xx	KVA Amperes	0.60 5.0	0.90 7.5	1.50 12.5	3.0 25.0	4.5 37.5	6.0 50.0	9.0 75.0	12.0 100	18.0 150	30.0 250	2	56-B
120	152	416-12xx	KVA Amperes	0.47 3.91	0.71 5.91	1.18 9.83	2.3 19.1	3.5 29.1	4.7 39.1	7.1 59.1	9.5 79.1	14.2 118	23.0 191	2	56-B
200	240	416-14xx	KVA Amperes	0.50 2.50	0.75 3.75	1.25 6.25	2.5 12.5	3.7 18.7	5.0 25.0	7.5 37.5	10.0 50.0	15.0 75.0	25.0 125	2	56-B
208	236	416-12xx	KVA Amperes	0.73 3.53	1.1 5.28	1.84 8.82	3.6 17.4	5.5 26.4	7.3 35.3	11.0 52.8	14.7 70.7	22.1 106	36.8 174	4	56-D
212	240	416-12xx	KVA Amperes	0.75 3.53	1.12 5.28	1.87 8.82	3.7 17.4	5.6 26.4	7.5 35.3	11.2 52.8	15.0 70.7	22.5 106	37.0 174	4	56-D

Low Voltage (LV)	High Voltage (HV)	Catalog Number	Load Required	01	11	21	31	41	51	61	71	81	91	New Diagram #	Old Diagram #
208	230	416-11xx	KVA Amperes	0.95 4.58	1.4 6.88	2.3 11.4	4.7 22.9	7.1 34.4	9.5 45.8	14.3 68.8	19.0 91.7	28.6 137	47.6 229	4	56-D
218	240	416-11xx	KVA Amperes	1.0 4.58	1.5 6.88	2.5 11.4	5.0 22.9	7.5 34.4	10.0 45.8	15.0 68.8	20.0 91.7	30.0 137	50.0 229	4	56-D
225	240	416-12xx	KVA Amperes	1.5 6.66	2.25 10.0	3.75 16.6	7.5 33.3	11.2 49.7	15.0 66.6	22.5 100	30.0 133	45.0 200	75.0 333	3	56-C
230	276	416-14xx	KVA Amperes	0.57 2.5	0.86 3.75	1.43 6.25	2.8 12.5	4.3 18.7	5.7 25.0	8.6 37.5	11.5 45.0	17.2 75.0	28.7 124	2	56-B
240	252	416-11xx	KVA Amperes	2.1 8.75	3.15 13.1	5.25 21.8	10.5 43.7	15.7 65.4	21.0 87.5	31.5 131	42.0 175	63.0 262	105 437	3	56-C
240	264	416-11xx	KVA Amperes	1.1 4.58	1.65 6.87	2.75 11.4	5.5 22.9	8.2 34.1	11.0 45.8	16.5 68.7	22.0 91.6	33.0 137	55.0 229	4	56-D
240	272	416-12xx	KVA Amperes	0.85 3.54	1.27 5.29	2.12 8.83	4.2 17.5	6.3 26.2	8.5 35.4	12.7 52.9	17.0 70.8	25.5 106	42.0 175	4	56-D
240	288	416-14xx	KVA Amperes	0.60 2.5	0.90 3.75	1.5 6.25	3.0 12.5	4.5 18.7	6.0 25.0	9.0 37.5	12.0 50.0	18.0 75.0	30.0 125	2	56-B
437	480	416-14xx	KVA Amperes	1.0 2.28	1.5 3.43	2.5 5.72	5.0 11.4	7.5 17.1	10.0 22.8	15.0 34.3	20.0 45.7	30.0 68.6	50.0 114	4	56-D
457	480	416-14xx	KVA Amperes	2.0 4.37	3.0 6.56	5.0 10.9	10.0 21.8	15.0 32.8	20.0 43.7	30.0 65.6	40.0 87.5	60.0 131	100 218	3	56-C
480	504	416-14xx	KVA Amperes	2.1 4.37	3.15 6.56	5.25 10.9	10.5 21.8	15.7 32.8	21.0 43.7	31.5 65.6	42.0 87.5	63.0 131	105 218	3	56-C
480	528	416-14xx	KVA Amperes	1.1 2.29	1.65 3.43	2.75 5.72	5.5 11.4	8.2 17.0	11.0 22.9	16.5 34.3	22.0 45.8	33.0 68.7	55.0 114	4	56-D

Open Delta Chart (requires 2 transformers)

Low Voltage (LV)	High Voltage (HV)	Catalog Number	Load Required	01	11	21	31	41	51	61	71	81	91	New Diagram #	Old Diagram #
200	240	416-14xx	KVA Amperes	0.86 2.1	1.29 3.1	2.1 5.1	4.3 10.3	6.4 15.4	8.6 20.7	12.9 31.0	17.2 41.4	25.0 60.1	43.0 103	10	57-B
208	236	416-12xx	KVA Amperes	1.27 3.1	1.91 4.7	3.1 7.6	6.3 15.4	9.5 23.2	12.7 31.1	19.1 46.7	25.5 62.4	38.2 93.4	63.7 156	12	57-D
212	240	416-12xx	KVA Amperes	1.29 3.1	1.94 4.7	3.2 7.7	6.4 15.4	9.7 23.3	12.9 31.0	19.4 46.7	25.8 62.1	38.0 91.4	64.0 154	12	57-D
208	230	416-11xx	KVA Amperes	1.65 4.1	2.47 6.2	4.1 10.3	8.2 20.6	12.3 30.9	16.5 41.4	24.7 62.0	33.0 82.8	49.5 124	82.5 207	12	57-D
218	240	416-11xx	KVA Amperes	1.73 4.2	2.59 6.2	4.3 10.3	8.6 20.7	12.9 31.0	17.3 41.6	25.9 62.3	34.6 83.2	51.0 123	86.0 207	12	57-D
225	240	416-12xx	KVA Amperes	2.59 6.2	3.89 9.4	6.4 15.4	12.9 31.0	19.4 46.7	25.9 62.3	38.9 93.6	51.9 124.8	77.0 185	129 310	11	57-C
229	240	416-11xx	KVA Amperes	3.46 8.3	5.18 12.5	8.6 20.7	17.3 41.6	25.9 62.3	34.6 83.2	51.8 124.6	69.2 166.5	103 248	173 416	11	57-C
230	253	416-14xx	KVA Amperes	1.81 4.1	2.72 6.2	4.5 10.3	9.0 20.5	13.6 31.0	18.1 41.3	27.2 62.1	36.3 82.8	54.0 123	90.0 205	9	57-A
230	276	416-14xx	KVA Amperes	0.99 2.1	1.49 3.1	2.4 5.0	4.9 10.2	7.4 15.5	9.9 20.7	14.9 31.2	19.9 41.6	29.0 60.7	49.0 103	10	57-B
240	252	416-11xx	KVA Amperes	3.64 8.3	5.47 12.5	9.1 20.8	18.2 41.7	27.2 62.3	36.4 83.4	54.7 125.3	72.8 166.8	109 250	182 417	11	57-C
240	264	416-11xx	KVA Amperes	1.9 4.2	2.86 6.3	4.7 10.3	9.5 20.8	14.2 31.1	19.0 41.6	28.6 62.5	38.1 83.3	57.0 125	95.0 208	12	57-D
240	272	416-12xx	KVA Amperes	1.47 3.1	2.2 4.7	3.6 7.6	7.3 15.5	11.0 23.3	14.7 31.2	22.0 46.7	29.4 62.4	44.1 93.6	73.6 156	12	57-D
240	288	416-14xx	KVA Amperes	1.03 2.1	1.55 3.1	2.5 5.0	5.1 10.2	7.7 15.4	10.3 20.6	15.5 31.1	20.7 41.5	31.0 62.1	51.0 102	10	57-B
437	480	416-14xx	KVA Amperes	1.73 2.1	2.59 3.1	4.3 5.2	8.6 10.3	12.9 15.5	17.3 20.8	25.9 31.2	34.6 41.6	51.0 61.3	86.0 103	12	57-D
457	480	416-14xx	KVA Amperes	3.46 4.2	5.18 6.2	8.6 10.3	17.3 20.8	25.9 31.2	34.6 41.6	51.8 62.3	69.2 83.2	103 124	173 208	11	57-C

Low Voltage (LV)	High Voltage (HV)	Catalog Number	Load Required	01	11	21	31	41	51	61	71	81	91	New Diagram #	Old Diagram #
480	504	416-14xx	KVA Amperes	3.64 4.2	5.47 6.3	9.1 10.4	18.2 20.8	27.2 31.2	36.4 41.7	54.7 62.7	72.8 83.4	109 125	183 210	11	57-C
480	528	416-14xx	KVA Amperes	1.9 2.1	2.86 3.1	4.7 5.1	9.5 10.4	14.2 15.5	19.0 20.8	28.6 31.3	38.1 41.7	57.0 62.3	95.0 104	12	57-D

Wye Chart (requires 3 transformers)

Low Voltage (LV)	High Voltage (HV)	Catalog Number	Load Required	01	11	21	31	41	51	61	71	81	91	New Diagram #	Old Diagram #
164	208	416-12xx	KVA Amperes	1.1 3.89	1.7 5.89	2.8 9.79	5.6 18.9	8.4 29.4	11.2 38.9	16.8 58.9	22.0 78.9	34.0 117	56.0 197	6	58-B
173	208	416-11xx	KVA Amperes	1.50 5.0	2.20 7.5	3.7 12.5	7.5 25.0	11.2 37.0	15.0 50.0	22.5 75.0	30.0 100	45.0 150	75.0 250	6	58-B
183	208	416-12xx	KVA Amperes	2.2 7.07	3.3 10.5	5.6 17.6	11.2 34.9	16.8 52.8	22.5 70.7	33.7 105	45.0 141	67.0 212	112 354	5	58-A
189	208	416-11xx	KVA Amperes	3.0 9.17	4.5 13.7	7.5 22.9	15.0 45.8	22.5 68.8	30.0 91.7	45.0 137	60.0 183	90.0 275	150 458	5	58-A
208	229	416-11xx	KVA Amperes	3.3 9.17	4.9 13.7	8.2 22.9	16.5 45.8	24.7 68.8	33.0 91.7	49.5 137	66.0 183	99.0 275	165 458	5	58-A
208	235	416-12xx	KVA Amperes	2.5 7.08	3.8 10.5	6.3 17.6	12.7 35.0	19.1 52.5	25.5 70.8	38.2 105	51.0 141	76.5 212	127 350	5	58-A
208	249	416-11xx	KVA Amperes	1.80 5.0	2.70 7.5	4.5 12.5	9.0 25.0	13.5 37.5	18.0 50.0	27.0 75.0	36.0 100	54.0 150	90.0 250	6	58-B
208	263	416-12xx	KVA Amperes	1.4 3.91	2.1 5.91	3.5 9.83	7.1 19.1	10.6 29.1	14.2 39.1	21.4 59.1	28.0 79.1	42.0 118	71.0 191	6	58-B
346	416	416-14xx	KVA Amperes	1.50 2.5	2.2 3.75	3.7 6.25	7.5 12.5	11.2 18.5	15.0 25.0	22.5 37.5	30.0 50.0	45.0 75.0	75.0 125	6	58-B
367	416	416-12xx	KVA Amperes	2.2 3.53	3.3 5.28	5.6 8.82	11.2 17.4	16.8 26.4	22.5 35.3	33.7 52.8	45.0 70.7	67.0 106	112 174	8	58-D

Low Voltage (LV)	High Voltage (HV)	Catalog Number	Load Required	01	11	21	31	41	51	61	71	81	91	New Diagram #	Old Diagram #
378	416	416-11xx	KVA Amperes	3.0 4.58	4.5 6.88	7.5 11.4	15.0 22.9	22.5 34.4	30.0 45.8	45.0 68.8	60.0 91.7	90.0 137	150 229	8	58-D
390	416	416-12xx	KVA Amperes	4.5 6.66	6.7 10.0	11.2 16.6	22.5 33.3	33.7 49.7	45.0 66.6	67.5 100	90.0 133	135 200	225 333	7	58-C
397	416	416-11xx	KVA Amperes	6.0 8.73	9.0 13.1	15.0 21.8	30.0 43.6	45.0 65.5	60.0 87.3	90.0 131	120 174	180 262	300 436	7	58-C
398	438	416-14xx	KVA Amperes	3.1 4.56	4.7 6.82	7.8 11.3	15.7 22.6	23.6 33.9	31.5 45.6	47.2 68.2	63.0 91.3	94.0 136	157 229	5	58-A
398	478	416-14xx	KVA Amperes	1.7 2.50	2.5 3.75	4.3 6.25	8.6 12.5	12.9 18.7	17.2 25.0	25.9 37.5	34.0 50.0	51.0 75.0	86.0 125	6	58-B
416	437	416-11xx	KVA Amperes	6.3 8.75	9.4 13.1	15.7 21.8	31.5 43.7	47.2 65.4	63.0 87.5	94.5 131	126 175	189 262	315 437	7	58-C
416	443	416-12xx	KVA Amperes	4.8 6.66	7.2 10.0	12.0 16.6	24.0 33.3	36.0 50.0	48.0 66.6	72.0 100	96.0 133	144 200	240 333	7	58-C
416	457	416-11xx	KVA Amperes	3.3 4.58	4.9 6.87	8.2 11.4	16.5 22.9	24.7 34.1	33.0 45.8	49.5 68.7	66.0 91.6	99.0 137	165 229	8	58-D
416	471	416-12xx	KVA Amperes	2.5 3.54	3.8 5.29	6.3 8.83	12.7 17.5	19.1 26.2	25.5 35.4	38.2 52.9	51.0 70.8	76.5 106	127 175	8	58-D
416	498	416-14xx	KVA Amperes	1.80 2.5	2.7 3.75	4.5 6.25	9.0 12.5	13.5 18.7	18.0 25.0	27.0 37.5	36.0 50.0	54.0 75.0	90.0 125	6	58-B

IV. Connection Instructions and Diagrams

Single Phase

WIRING DIAGRAM #1 (56-A)

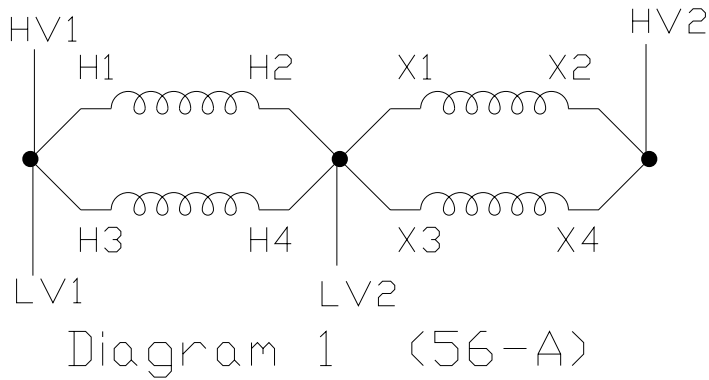

Step 1: Connect LV1, H1, H3 & HV1 together.

Step 2: Connect H2, H4, LV2, X1 & X3 together.

Step 3: Connect X2, X4 & HV2 together.

WIRING DIAGRAM #2 (56-B)

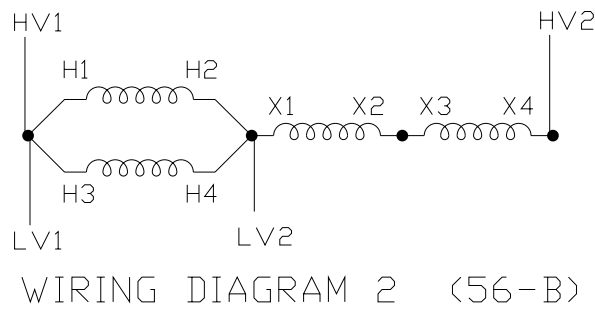

Step 1: Connect LV1, H1, H3 & HV1 together.

Step 2: Connect H2, H4, LV2 & X1 together.

Step 3: Connect X2 & X3 together.

Step 4: Connect X4 & HV2 together.

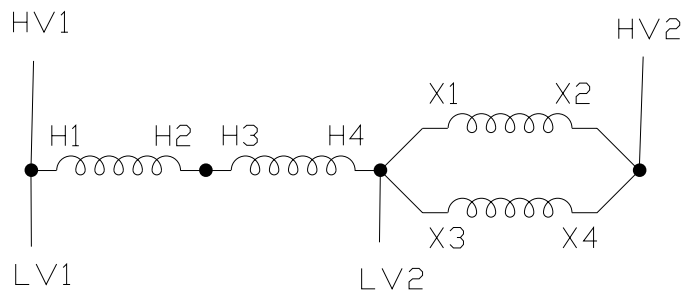
WIRING DIAGRAM #3 (56-C)

WIRING DIAGRAM 3 (56-C)

- Step 1: Connect LV1, H1 & HV1 together.
- Step 2: Connect H2 & H3 together.
- Step 3: Connect H4, LV2, X1 & X3 together.
- Step 4: Connect X2, X4 & HV2 together.

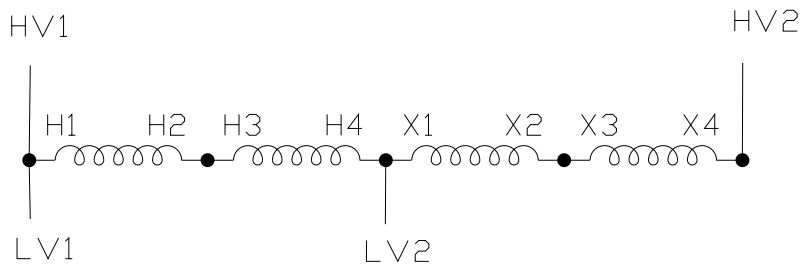
WIRING DIAGRAM #4 (56-D)

WIRING DIAGRAM 4 (56-D)

- Step 1: Connect LV1, H1 & HV1 together.
- Step 2: Connect H2 & H3 together.
- Step 3: Connect H4, LV2 & X1 together.
- Step 4: Connect X2 & X3 together.
- Step 5: Connect X4 & HV2 together

3 Phase Wye

WIRING DIAGRAM #5 (58-A)

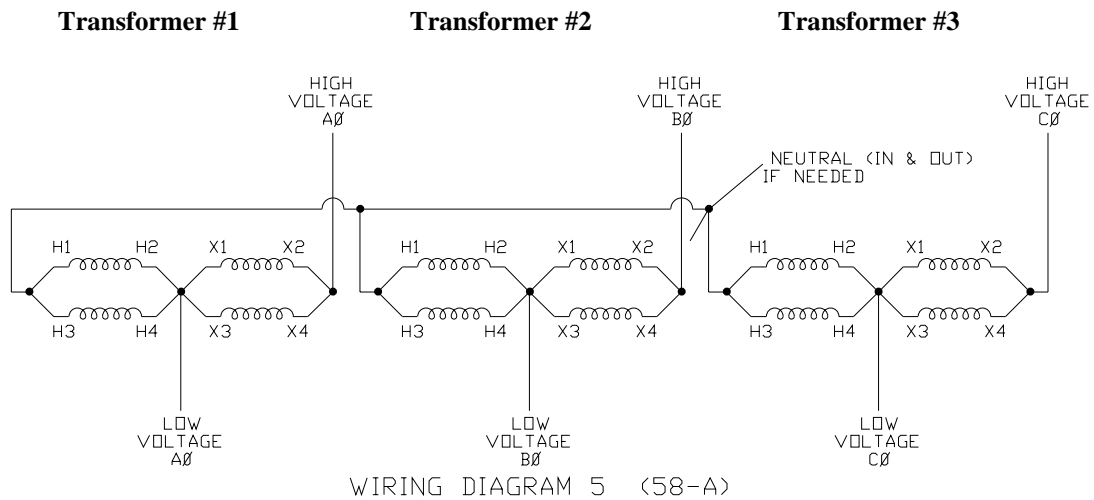

Part A (Transformer #1):

Step 1: Connect H1 & H3 together.

Step 2: Connect H2, H4, X1, X3 & LOW VOLTAGE AØ-Phase together.

Step 3: Connect X2, X4 & HIGH VOLTAGE AØ-Phase together.

Part B (Transformer #2):

Step 1: Connect H1 & H3 together.

Step 2: Connect H2, H4, X1, X3 & LOW VOLTAGE BØ-Phase together.

Step 3: Connect X2, X4 & HIGH VOLTAGE BØ-Phase together.

Part C (Transformer #3):

Step 1: Connect H1 & H3 together.

Step 2: Connect H2, H4, X1, X3 & LOW VOLTAGE CØ-Phase together.

Step 3: Connect X2, X4 & HIGH VOLTAGE CØ-Phase together.

Part D:

Connect H1 from Transformer #1, H1 from Transformer #2, H1 from Transformer #3, the LV neutral & the HV neutral together.

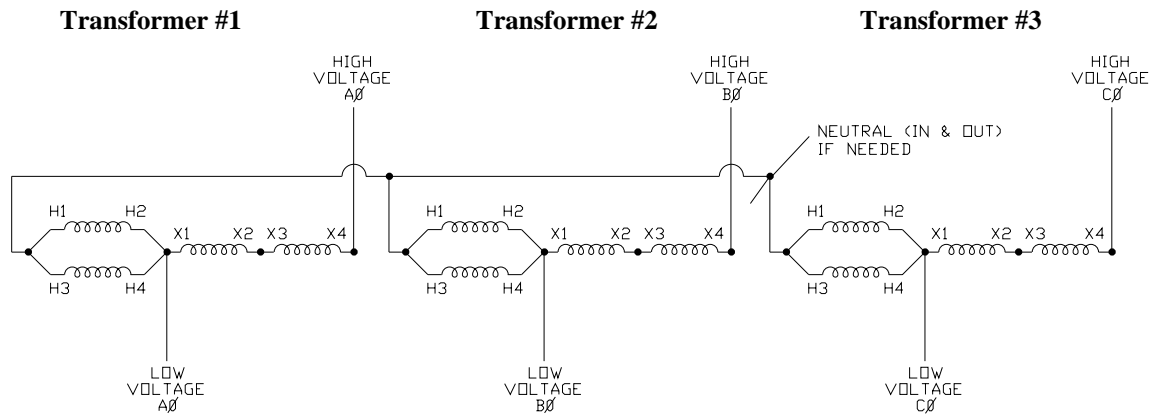
WIRING DIAGRAM #6 (58-B)

WIRING DIAGRAM 6 (58-B)

Part A (Transformer #1):

Step 1: Connect H1 & H3 together.

Step 2: Connect H2, H4, X1 & LOW VOLTAGE AØ-Phase together.

Step 3: Connect X2 & X3 together.

Step 4: Connect X4 & HIGH VOLTAGE AØ-Phase together.

Part B (Transformer #2):

Step 1: Connect H1 & H3 together.

Step 2: Connect H2, H4, X1 & LOW VOLTAGE BØ-Phase together.

Step 3: Connect X2 & X3 together.

Step 4: Connect X4 & HIGH VOLTAGE BØ-Phase together.

Part C (Transformer #3):

Step 1: Connect H1 & H3 together.

Step 2: Connect H2, H4, X1 & LOW VOLTAGE CØ-Phase together.

Step 3: Connect X2 & X3 together.

Step 4: Connect X4 & HIGH VOLTAGE CØ-Phase together.

Part D:

Connect H1 from Transformer #1, H1 from Transformer #2, H1 from Transformer #3, the LV neutral & the HV neutral together.

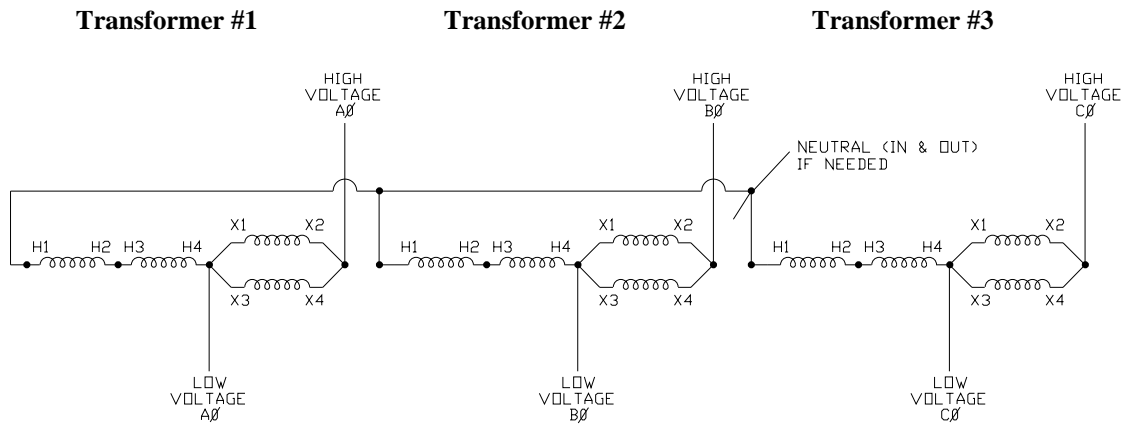
WIRING DIAGRAM #7 (58-C)

WIRING DIAGRAM 7 (58-C)

Part A (Transformer #1):

Step 1: Connect H2 & H3 together.

Step 2: Connect H4, X1, X3 & LOW VOLTAGE AØ-Phase together.

Step 3: Connect X2, X4 & HIGH VOLTAGE AØ-Phase together.

Part B (Transformer #2):

Step 1: Connect H2 & H3 together.

Step 2: Connect H4, X1, X3 & LOW VOLTAGE BØ-Phase together.

Step 3: Connect X2, X4 & HIGH VOLTAGE BØ-Phase together.

Part C (Transformer #3):

Step 1: Connect H2 & H3 together.

Step 2: Connect H4, X1, X3 & LOW VOLTAGE CØ-Phase together.

Step 3: Connect X2, X4 & HIGH VOLTAGE CØ-Phase together.

Part D:

Connect H1 from Transformer #1, H1 from Transformer #2, H1 from Transformer #3, the LV neutral & the HV neutral together.

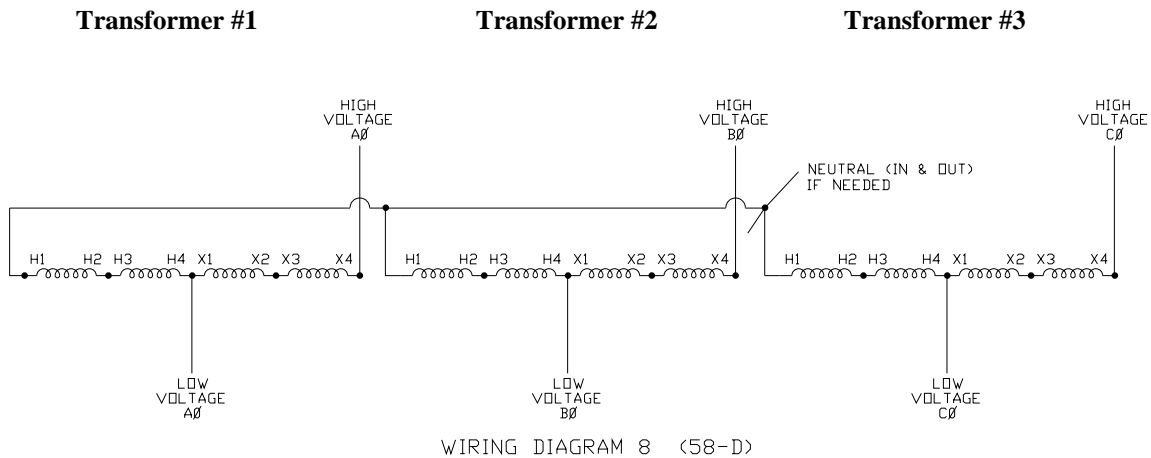
WIRING DIAGRAM #8 (58-D)**Part A (Transformer #1):**

- Step 1: Connect H2 & H3 together.
- Step 2: Connect H4, X1 & LOW VOLTAGE AØ-Phase together.
- Step 3: Connect X2 & X3 together.
- Step 4: Connect X4 & HIGH VOLTAGE AØ-Phase together.

Part B (Transformer #2):

- Step 1: Connect H2 & H3 together.
- Step 2: Connect H4, X1 & LOW VOLTAGE BØ-Phase together.
- Step 3: Connect X2 & X3 together.
- Step 4: Connect X4 & HIGH VOLTAGE BØ-Phase together.

Part C (Transformer #3):

- Step 1: Connect H2 & H3 together.
- Step 2: Connect H4, X1 & LOW VOLTAGE CØ-Phase together.
- Step 3: Connect X2 & X3 together.
- Step 4: Connect X4 & HIGH VOLTAGE CØ-Phase together.

Part D:

Connect H1 from Transformer #1, H1 from Transformer #2, H1 from Transformer #3, the LV neutral & the HV neutral together.

3 Phase Open Delta

WIRING DIAGRAM #9 (57-A)

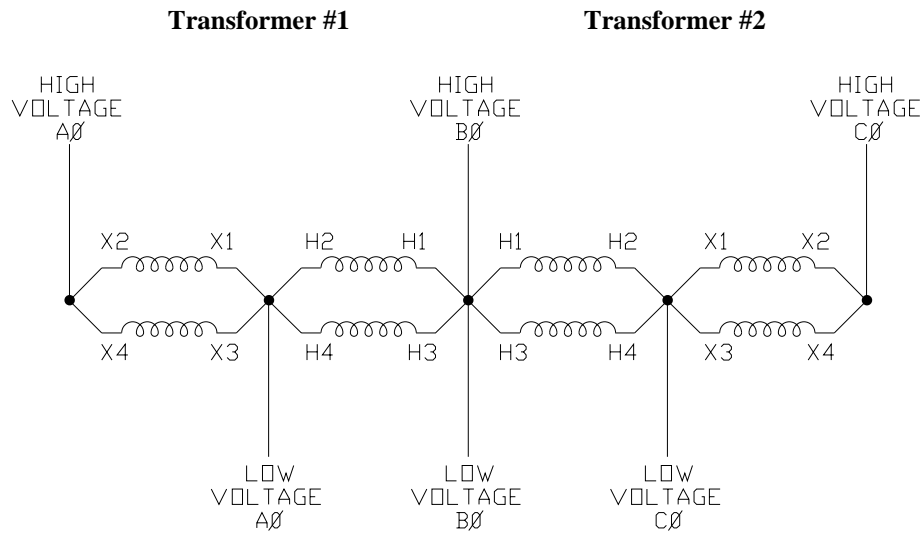

WIRING DIAGRAM 9 (57-A)

Part A (Transformer #1):

Step 1: Connect X2, X4 & HIGH VOLTAGE AØ-Phase together.

Step 2: Connect X1, X3, H2, H4 & LOW VOLTAGE AØ-Phase together.

Step 3: Connect H1 & H3 together.

Part B (Transformer #2):

Step 1: Connect X2, X4 & HIGH VOLTAGE CØ-Phase together.

Step 2: Connect X1, X3, H2, H4 & LOW VOLTAGE CØ-Phase together.

Step 3: Connect H1 & H3 together.

Part C:

Connect H1 from Transformer #1, H1 from Transformer #2, HIGH VOLTAGE BØ-Phase & LV B-Phase together.

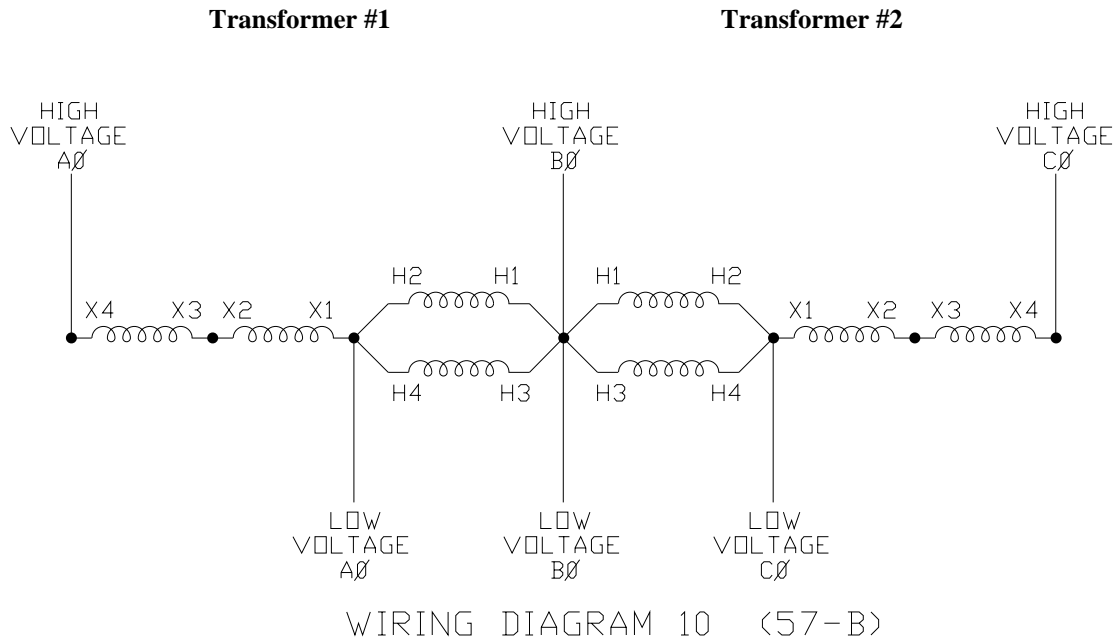
WIRING DIAGRAM #10 (57-B)**Part A (Transformer #1):**

- Step 1: Connect X4 & HIGH VOLTAGE AØ-Phase together.
- Step 2: Connect X2 & X3 together.
- Step 3: Connect X1, H2, H4 & LOW VOLTAGE AØ-Phase together.
- Step 4: Connect H1 & H3 together.

Part B (Transformer #2):

- Step 1: Connect X4 & HIGH VOLTAGE CØ-Phase together.
- Step 2: Connect X2 & X3 together.
- Step 3: Connect X1, H2, H4 & LOW VOLTAGE CØ-Phase together.
- Step 4: Connect H1 & H3 together.

Part C:

Connect H1 from Transformer #1, H1 from Transformer #2, HIGH VOLTAGE BØ-Phase & LV B-Phase together

WIRING DIAGRAM #11 (57-C)

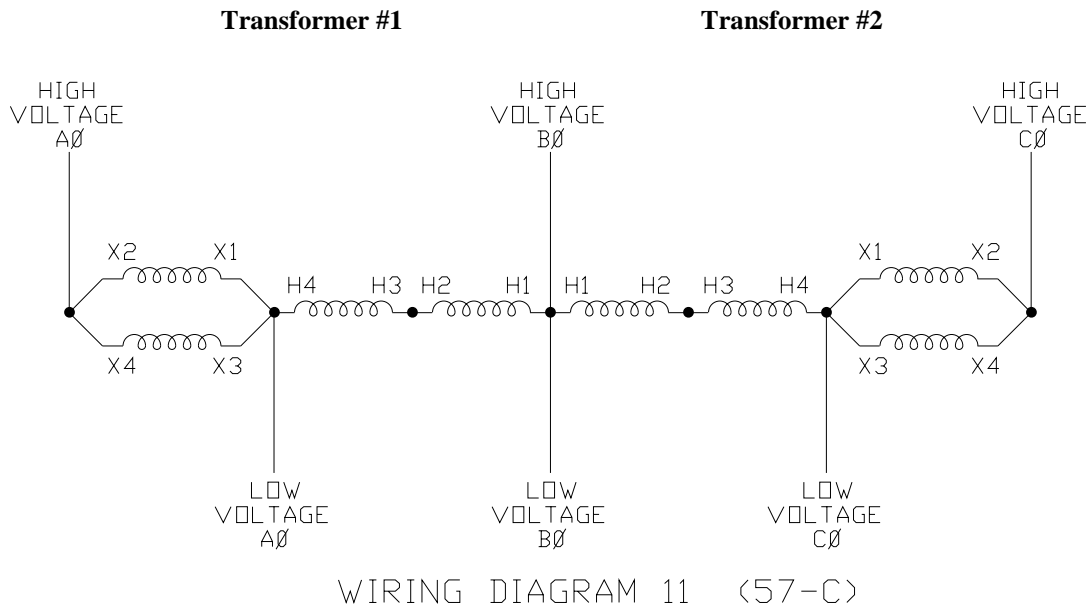

Part A (Transformer #1):

- Step 1: Connect X2, X4 & HIGH VOLTAGE AØ-Phase together.
- Step 2: Connect X1, X3, H4 & LOW VOLTAGE AØ-Phase together.
- Step 3: Connect H2 & H3 together.

Part B (Transformer #2):

- Step 1: Connect X2, X4 & HIGH VOLTAGE CØ-Phase together.
- Step 2: Connect X1, X3, H4 & LOW VOLTAGE CØ-Phase together.
- Step 3: Connect H2 & H3 together.

Part C:

Connect H1 from Transformer #1, H1 from Transformer #2, HIGH VOLTAGE BØ-Phase & LV B-Phase together.

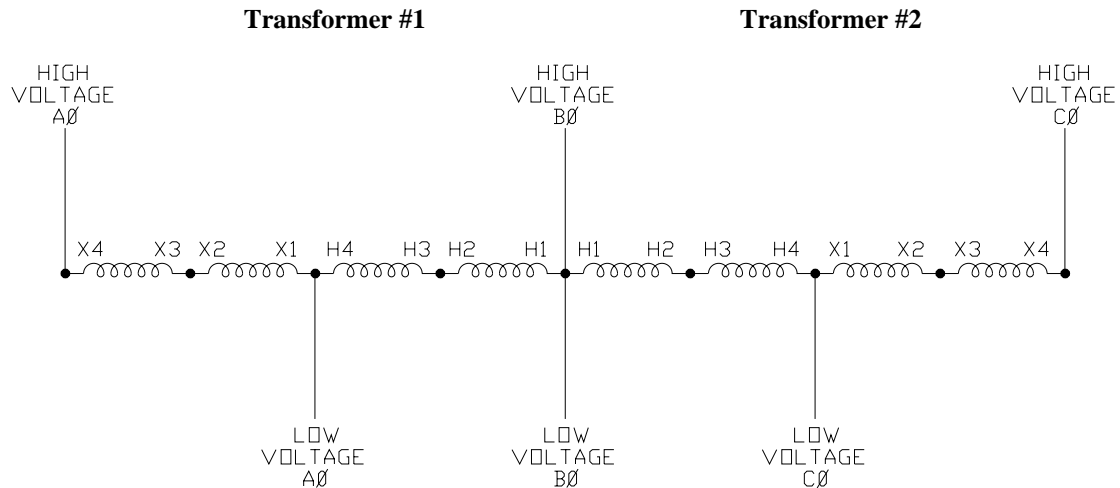
WIRING DIAGRAM #12 (57-D)

WIRING DIAGRAM 12 (57-D)

Part A (Transformer #1):

Step 1: Connect X4 & HIGH VOLTAGE AØ-Phase together.

Step 2: Connect X2 & X3 together.

Step 3: Connect X1, H4 & LOW VOLTAGE AØ-Phase together.

Step 4: Connect H2 & H3 together.

Part B (Transformer #2):

Step 1: Connect X4 & HIGH VOLTAGE CØ-Phase together.

Step 2: Connect X2 & X3 together.

Step 3: Connect X1, H4 & LOW VOLTAGE CØ-Phase together.

Step 4: Connect H2 & H3 together.

Part C:

Connect H1 from Transformer #1, H1 from Transformer #2, and HIGH VOLTAGE BØ-Phase & LV B-Phase together.

V. Typical Questions

- Q1. What is the difference between an autotransformer and an isolation transformer?*
- A1. In an isolation transformer the input and output are completely separated and all the energy is transformed. In an autotransformer the input and output are electrically connected. Only a portion of the electrical energy is changed in an autotransformer, the remainder flowing directly between the primary and the secondary. An autotransformer is typically smaller, lighter and less costly than a comparable isolation transformer.
- Q2. When using the transformer as a step-up (boost) does the lower voltage get connected to the LV or HV terminals?*
- A2. When connecting the Buck-Boost transformer per our wiring diagrams, the diagrams are not set up as step-up or step-down, they can be used in either application. The LV side is always the lower of the two voltages and the HV side is always the higher of the two voltages.
- Q3. Why do I measure different voltages between the lines and neutral? I purchased your unit and need to go from 208 volts to 240 volts, when I take my measurements from neutral to my lines I get 120 volts from one line to neutral and 130 to 140 volts from the other line to neutral.*
- A3. The measurements are correct, but this configuration is not recommended. The unequal voltages are due to the fact that one line is being boosted by 13.3%. See better solutions offered in the description of misapplication M1.
- Q4. Can I use a Buck-Boost Transformer to provide an output of 208Y/120 (or any other wye combination)?*
- A4. This all depends on your source. If you have a wye source, you can feed the wye through the autotransformer. If you have a High-Leg Delta or a 3-wire source, you can not create the wye for your application and must purchase an Isolation style transformer.
- Q5. When do I use an Open Delta configuration and when do I use a Wye configuration?*
- A5. This all depends on your load requirements. If your load requires a wye and you meet the criteria from question #4, then you need a wye configuration. If you have a 3-wire load it is your choice on the Open Delta or Wye configuration. Please note that you may want to take availability and cost of the transformers into consideration when you make your decision. An Open Delta requires 2 transformers compare to using 3 slightly smaller transformers for the wye configuration.

- Q6. Why does the nameplate read High Volts = 120 x 240 and Low Volts = 12/24, when the chart shows that I can connect 208 volts in and 229 volts out ?*
- A6. The nameplate shows the rating for when the unit is used as an isolation transformer. When the transformers are used as auto-transformers they are only “transforming” a portion of the total voltage.
- Q7. Why do I have larger capacity wire then what is in the transformer?*
- A7. You have a larger capacity wire because you have sized yours for the current that is required for your load and source. Our wires are smaller in capacity because of the features of an autotransformer that subtracts the current in the common coil. Since the current that will flow through our wires is less, the capacity of the wire can be smaller.

VI. Misapplications

- M1. Pulling the neutral around the transformer on a single-phase application. This usually occurs when the source voltage is 208Y/120 and you need to feed a single-phase panel with 120/240.

What occurs is that you size the buck-boost unit to go from 208 volts up to 240 (236) volts, obtain the units and boost the voltage between your lines from 208 volts to 236 volts. You pull this new voltage to the panel and since the panel requires a neutral, you take the neutral from your 208Y/120 source and pull it to the panel.

When taking voltage measurements you realize that from one line to neutral is 120 volts, but from the other line to neutral you have a higher voltage than 120, somewhere between 130 and 145 volts. This occurs because on the autotransformer connection line one is a common line between the input and the output. Since it is directly connected to the input, the voltage between line and neutral stays at 120 volts. The other line has been boosted 13.3%, so the voltage to neutral has also been boosted. That is why the voltage is higher than 120 volts.

Two Solutions:

1. The correct transformer is an isolation transformer rated 208 volts to 120/240 volts.
2. A second choice is to use the buck-boost transformer for the 240 volt loads only, the 120 volt loads can be fed by using the source 208Y/120 volts.

- M2. Using a buck-boost transformer to correct voltage drop. This application is load dependent, voltage drop occurs because of $I^2 \times R$ losses. (These losses are also

called copper losses and increase as the load increases causing a larger voltage drop.) Since the current is dependent on the load, the voltage drop will fluctuate with the amount of load. The buck-boost units will correct the voltage drop at a constant percentage of the input voltage, if the input voltage changes as the load changes the output voltage will change at the same rate. If your load cannot function with a change in voltage, the best alternative is a regulator instead of a buck-boost transformer.

- M3. Deriving a neutral with the buck-boost transformer, this is against the N.E.C. section 210-9. The buck-boost transformers are autotransformers and cannot create a neutral if you do not have a neutral.

This application requires a Delta to Wye isolation transformer.

Jefferson Electric

9650 S Franklin Drive, Franklin, WI 53132-8847

Ph: 414-209-1620 or 800-892-3755

Fax: 414-209-1621

E-mail: info@jeffersonelectric.com

Web: <http://www.jeffersonelectric.com>

Buck-Boost Application Manual

Revised 02-15-2012