

**Heat Exchanger Kit, Model FPTN101-SA  
P/N 51024420101**



**READ ALL INSTRUCTIONS CAREFULLY BEFORE ATTEMPTING TO ASSEMBLE, INSTALL, OPERATE OR MAINTAIN THE PRODUCT DESCRIBED. PROTECT YOURSELF AND OTHERS BY OBSERVING ALL SAFETY INFORMATION. FAILURE TO COMPLY WITH INSTRUCTIONS COULD RESULT IN PERSONAL INJURY AND/OR PROPERTY DAMAGE!**

**RETAIN INSTRUCTIONS FOR FUTURE REFERENCE.**

**WARNING: THIS INSTRUCTION MANUAL IS INTENDED FOR USE BY QUALIFIED INDIVIDUALS WITH A WORKING KNOWLEDGE OF HYDRAULIC AND ELECTRICAL PRINCIPLES. PROFESSIONAL INSTALLATION IS RECOMMENDED.**

**Attention: This manual provides information on how to convert the return filter manifold and how to install the heat exchanger on a specific version of hydraulic power unit. These instructions are for use by properly trained individuals familiar with hydraulic components, hydraulic fittings, and the correct use of the appropriate hand tools.**

1. Heat exchanger kit, model FPTN101-SA

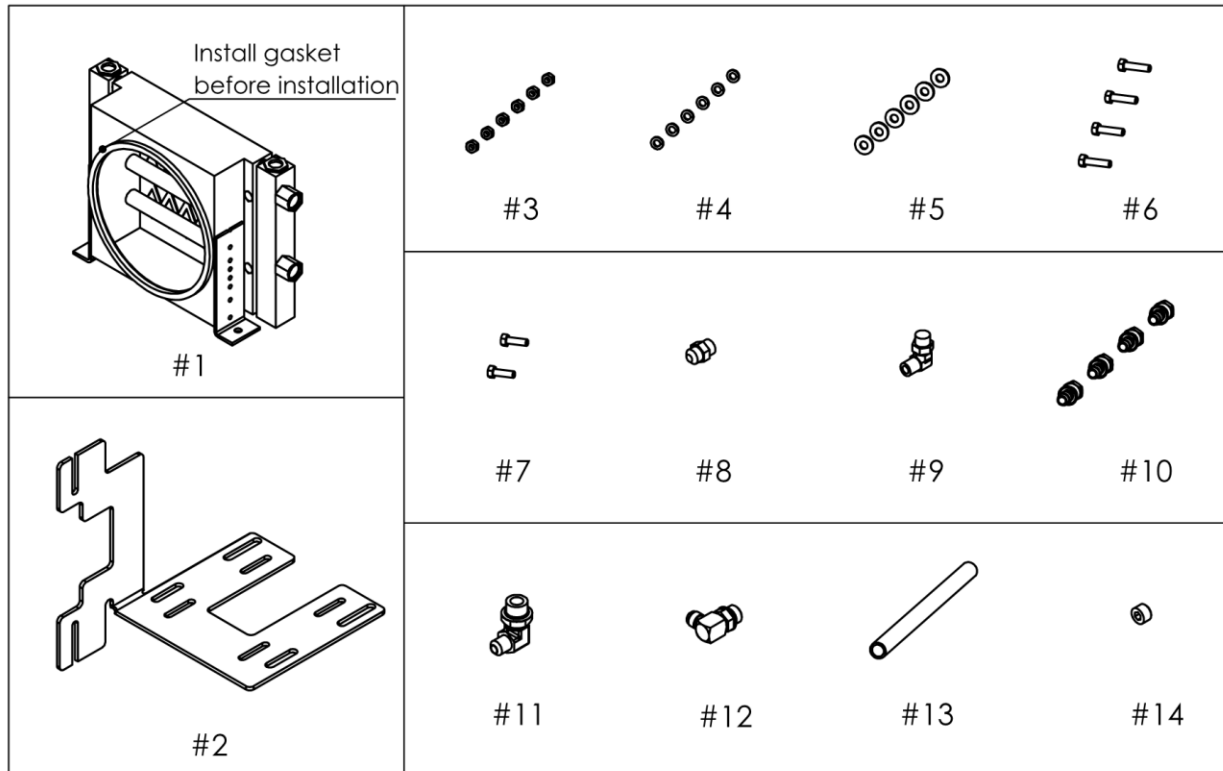

#	JDE Number	Part Number	Description	Qty	Unit
1	51020420050	ZPRM-08-22	A/O HEAT EXCH,RM,48~184,SAE PT	1	PC
2	51020101429	FPN1429	BRACKET FOR RM-08&56C~184TC MT	1	PC
3	500205207790	FP7790	NUT,HEX,5/16-18	6	PC
4	500208607781	FP7781	WASHER,LOCK,5/16	6	PC
5	500208607801	FP7801	WASHER,FLAT,5/16in,(UNPLATED)	6	PC
6	51020691434	FPN1434	SCREW HEX HEAD,5/16-16UNC X1.5	4	PC
7	500206907766	FP7766	SCREW,H.H.CAP,5/16-18 X 1	2	PC
8	51020330283	ZH848FSO-08-08	ADAPTER,#8 JICM X #8 SAE M	1	PC
9	51020330329	ZH849FSO-08-08	ELBOW,90 DEG,#8 SAE MALE X #8	1	PC
10	51020330566	ZKKA08-08NJ	HOSE END,1/2" PUSHLOCK TO #8 JI	4	PC
11	51020330331	ZH849FSO-08-12	FITTING ADAPTER,#08JIC-#12SAEM	1	PC
12	51020330330	ZH849FSO-08-10	ELBOW,90 DEG.,#8JICM TO #10SAE	1	PC
13	51020440013	ZM08L3S-BK	HOSE,1/2" PUSHLOCK	4	FT
14	500205902348	FP2348	PLUG,PIPE,FLUSH,1/2"-14NPT	1	PC

2. Hydraulic power unit shown without heat exchanger, before conversion.

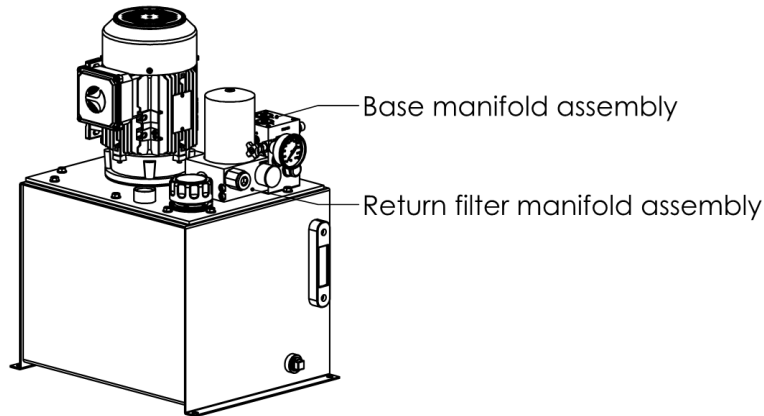

3. **The path of fluid through the return filter manifold must first be modified as follows:**

- A. Unscrew the filler/breather cap from the reservoir and set it aside.
- B. Loosen the (4) pcs of socket head cap screws holding the filter manifold to the base manifold and remove the filter assembly.
- C. Install the ½" NPT plug (item #14 on page 1) into the base manifold as shown below and ensure that the o'ring around this passage remains in place.
- D. Remove the #10 SAE plug from the rear port of the base manifold and install the 90° elbow (item #12 from page 1). Position the elbow to point vertically and tighten the lock nut (do not over tighten).
- E. Remove the #12 SAE plug from the adapter in the filter manifold return port and install the 90° elbow (item #11 from page 1). Position the elbow to point vertically and tighten the lock nut (do not over tighten).
- F. Ensure that all the o'rings are in place on the base manifold and reinstall the return filter manifold assembly to the base manifold. Snug up all (4) socket head cap screws then torque to 9 ft.lb <108 in.lb>.
- G. Reinstall the filler / breather cap.

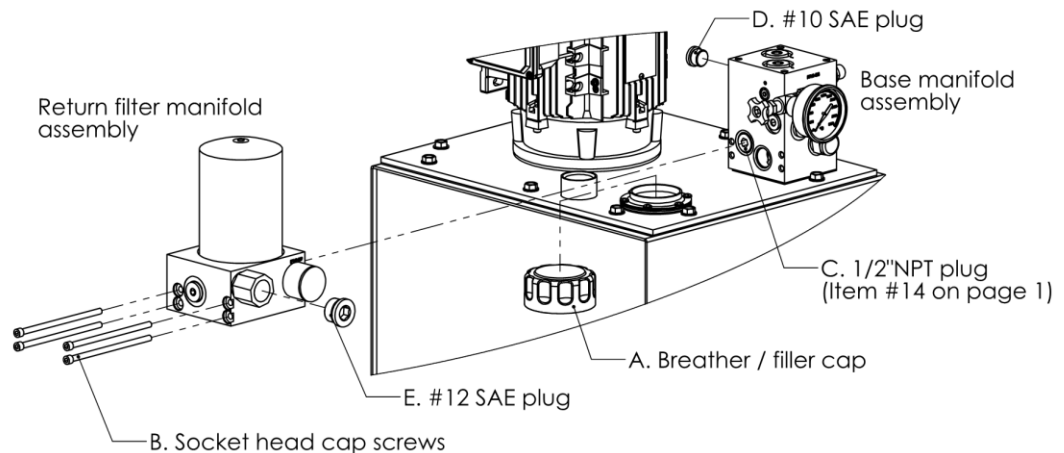

4. Install the heat exchanger bracket, heat exchanger, fittings, and hoses to the hydraulic unit per the instructions below and the diagram on page 4 as follows:
  - A. Install the heat exchanger bracket to the motor using the four pcs of 1.5" long bolts (item #6 on page 1), washers and nuts provided and leave these slightly loose to allow alignment of the bracket and heat exchanger.
  - B. Install the rubber gasket to the heat exchanger housing opening (cut off any excess length) then position the heat exchanger on top of the electric motor and install the two pcs of 1" long bolts (item #7 on page 1), washers, and nuts to secure the heat exchanger to the bracket (leave slightly loose to allow alignment).
  - C. Align the bracket and heat exchanger on top of the electric motor so that the heat exchanger sits level on the fan shroud of the motor (there should be no gaps between the rubber gasket and the fan shroud). Snug up then tighten the 6 fasteners (4 holding the bracket to the motor and 2 holding the heat exchanger to the bracket).
  - D. Install the 90° elbow (item #9 from page 1) into the inlet port of the heat exchanger and position per the diagram on page 4 then tighten the lock nut. **Note, the heat exchanger core uses copper tubing so the inlet and outlet ports must be held with a wrench when the fittings are tightened.**
  - E. Install the straight fitting (item #8 from page 1) into the outlet port of the heat exchanger and hold the heat exchanger port position with a wrench when tightening the fitting.
  - F. Cut the ½" push-on hose (item #13 from page 1) into two pcs, 16" long each and install the (4) barbed hose ends (item #10 from page 1) by placing the hex end of the fitting against a flat surface and pushing the hose over the barb until the end of the hose meets the yellow plastic ring near the hex.
  - G. Install one hose assembly between the base manifold and the heat exchanger inlet and the 2nd hose between the heat exchanger outlet and the return filter manifold inlet as shown on the diagram then tighten all 4 hose ends making sure to hold the fittings at the heat exchanger with a wrench to avoid damage to the copper heat exchanger connections. **Note, the barbed fittings have swivel ends so ensure that the hoses do not rotate when tightening as this may kink the hoses causing excess back pressure through the hoses.**

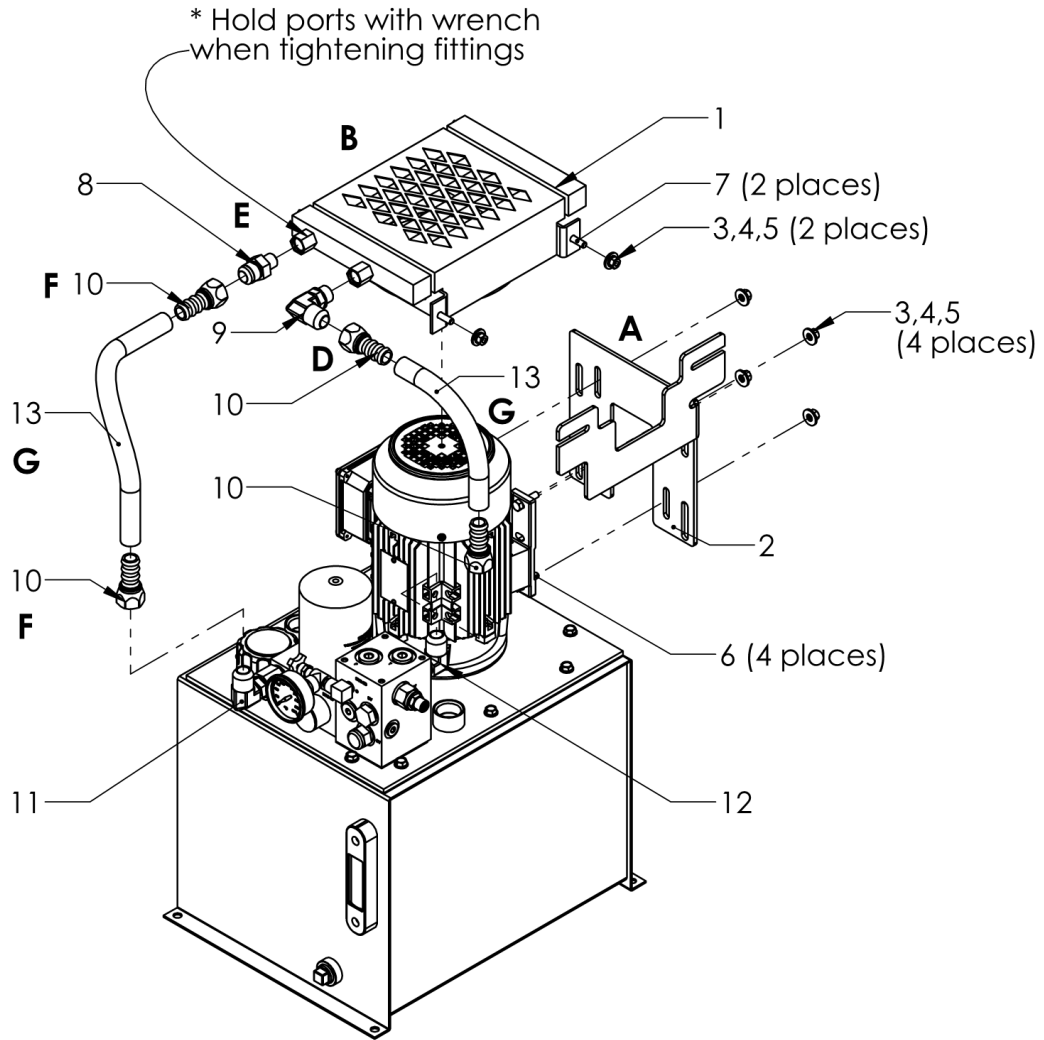



---

**Notes:**

- A. The heat exchanger core uses copper tubing so the inlet and outlet ports must be held with a wrench when the fittings are tightened.
  - B. The barbed fittings have swivel ends so ensure that the hoses do not rotate when tightening as this may kink the hoses causing excess back pressure through the hoses.
  - C. SAE fittings use o’rings to seal so do not over tighten.
-

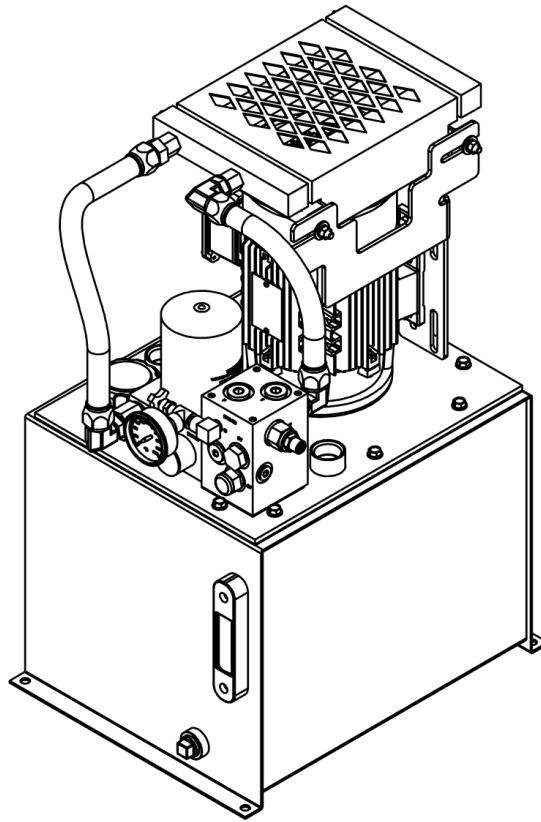
5. Hydraulic power unit shown with heat exchanger installed.

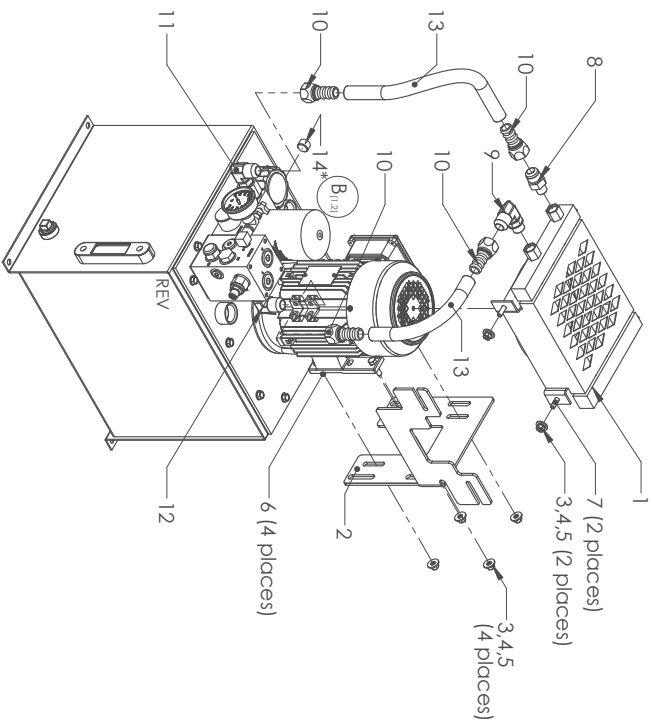



\* Please refer to the FPTN101-SA installation manual to install #14, 1/2"NPT plug, into the base manifold.

#	JDE Number	Part Number	Description	Qty	Unit
1	51020420050	ZPRM-08-22	A/O HEAT EXCH,RM,48~184,SAE PT	1	PC
2	51020101429	FPN1429	BRACKET FOR RM-08&56C~184TC MT	1	PC
3	500205207790	FP7790	NUT,HEX,5/16-18	6	PC
4	500208607781	FP7781	WASHER,LOCK,5/16	6	PC
5	500208607801	FP7801	WASHER,FLAT,5/16in,(UNPLATED)	6	PC
6	51020691434	FPN1434	SCREW,HEX HEAD,5/16-16UNC X1.5	4	PC
7	500206907766	FP7766	SCREW,H.H,CAP,5/16-18 X 1	2	PC
8	51020330283	ZH849FSO-08-08	ADAPTER,#8 JICM X #8 SAEM	1	PC
9	51020330329	ZH849FSO-08-08	ELBOW,90 DEG,#8 SAE MALE X #8	1	PC
10	51020330566	ZKKA08-08NJ	HOSE END,1/2" PUSHLCK TO #8 JI	4	PC
11	51020330331	ZH849FSO-08-12	FITTING ADAPTER,#08JIC-#12SAEM	1	PC
12	51020330330	ZH849FSO-08-10	ELBOW,90 DEG,#8JICM TO #10SAE	1	PC
13	51020440013	ZM08L3S-BK	HOSE,1/2" PUSHLCK	4	FT
14	500205902348	FP2348	PLUG,PIPE,FLUSH,1/2"-14NPT	1	PC

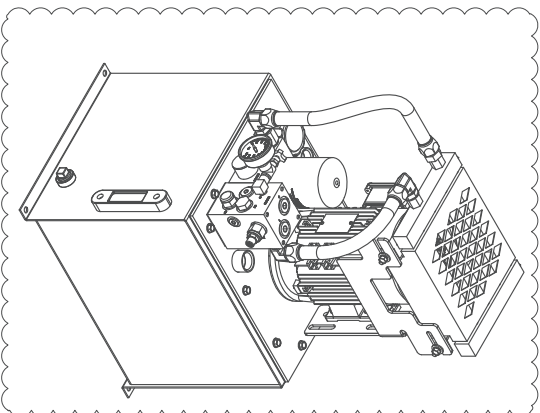

=>

DO NOT SCALE DRAWING	REV	QTY	DESCRIPTION	DATE	APPROVED
Critical dimension Dimension tolerance XX ±.010" XXX ±.005" Fraction ±.1/32 Angles ±.1/2° Remove burrs	B	1	1/2"NPT PLUG ADDED	10/16/2024	H.Z.
Location London,(ON)	Type of document ASSEMBLY DRAWING		Item No. 51024420101	Sem. Manuf. Part	H.Z.
Location London,(ON)	Description 1/2 FPTN101-SA HT EXR KIT,RM-08-22,56C~145TC		Customer 	EPV No. H.Z.	Dimension Material
<b>BUCHER hydraulics</b>	Description 1/2 FPTN101-SA HT EXR KIT,RM-08-22,56C~145TC		Weight (lbs) 	Created by X.L.	Released by H.Z.
This document contains information of a proprietary nature, which is the property of Bucher Hydraulics. Disclosure of this information is prohibited without written consent. It is specifically prohibited to be disclosed to any third party without written consent.			Drawing No. FPTN101-SA	Status RELEASED	Scale 1:9
Location London,(ON)			Weight (lbs) 	Created by X.L.	Released by H.Z.
Description 1/2 FPTN101-SA HT EXR KIT,RM-08-22,56C~145TC			Item No. 51024420101	Sem. Manuf. Part	H.Z.
Location London,(ON)			Customer 	EPV No. H.Z.	Dimension Material
Description 1/2 FPTN101-SA HT EXR KIT,RM-08-22,56C~145TC			Weight (lbs) 	Created by X.L.	Released by H.Z.
Location London,(ON)			Drawing No. FPTN101-SA	Status RELEASED	Scale 1:9
This document contains information of a proprietary nature, which is the property of Bucher Hydraulics. Disclosure of this information is prohibited without written consent. It is specifically prohibited to be disclosed to any third party without written consent.			Weight (lbs) 	Created by X.L.	Released by H.Z.