

English

## GENERAL INFORMATION

- NOTICE:** For installation by a qualified electrician in accordance with national and local electrical codes and the following instructions.
- CAUTION: RISK OF ELECTRIC SHOCK.** Disconnect power before installing. More than one disconnect switch may be required to de-energize this equipment before servicing. Disconnect **ALL** power supplies to enclosure before exposing interior.
- NOTICE:** Separate overcurrent protection must be provided in accordance with National Electrical Code® Article 220 or Canadian Electrical Code, Section B, as appropriate. Overcurrent protection **MUST NOT** exceed the ampere rating of the receptacle [ref.: National Electrical Code® section 430-42(c) or Canadian Electrical Code, Part 1, Rule 28-602(3)(c) (i)].
- Suitable for use on a circuit capable of delivering not more than 10,000 rms symmetrical amperes at the voltage rating of the receptacle.
- This enclosure includes a lockout provision to isolate the receptacle and connected equipment from the power supplied to the enclosure as a method of compliance to OSHA Lockout/Tagout Regulation 29, CFR Part 1910.147. The **ON-OFF** control knob (in the **OFF** position) accepts up to 5/16 inch (8 mm) diameter shackle of a suitable padlock or Lockout device. This feature does **NOT** isolate the power supplied to the enclosure during internal servicing of the enclosure.
- NOTICE:** This enclosure must **NOT** be used as a junction box for feed-through connections.
- The pilot contact (if installed) is rated A600 pilot duty, 600 VAC 10A.

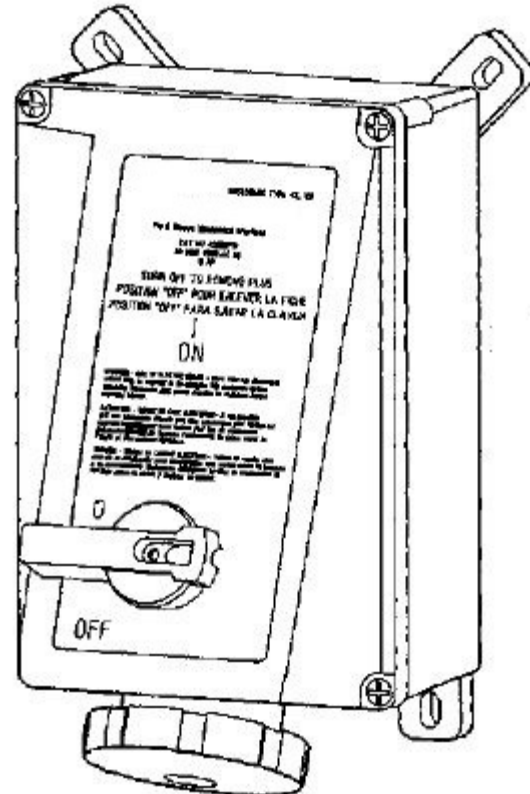

## BOTTOM FEED (RECOMMENDED METHOD OF ENTRY)

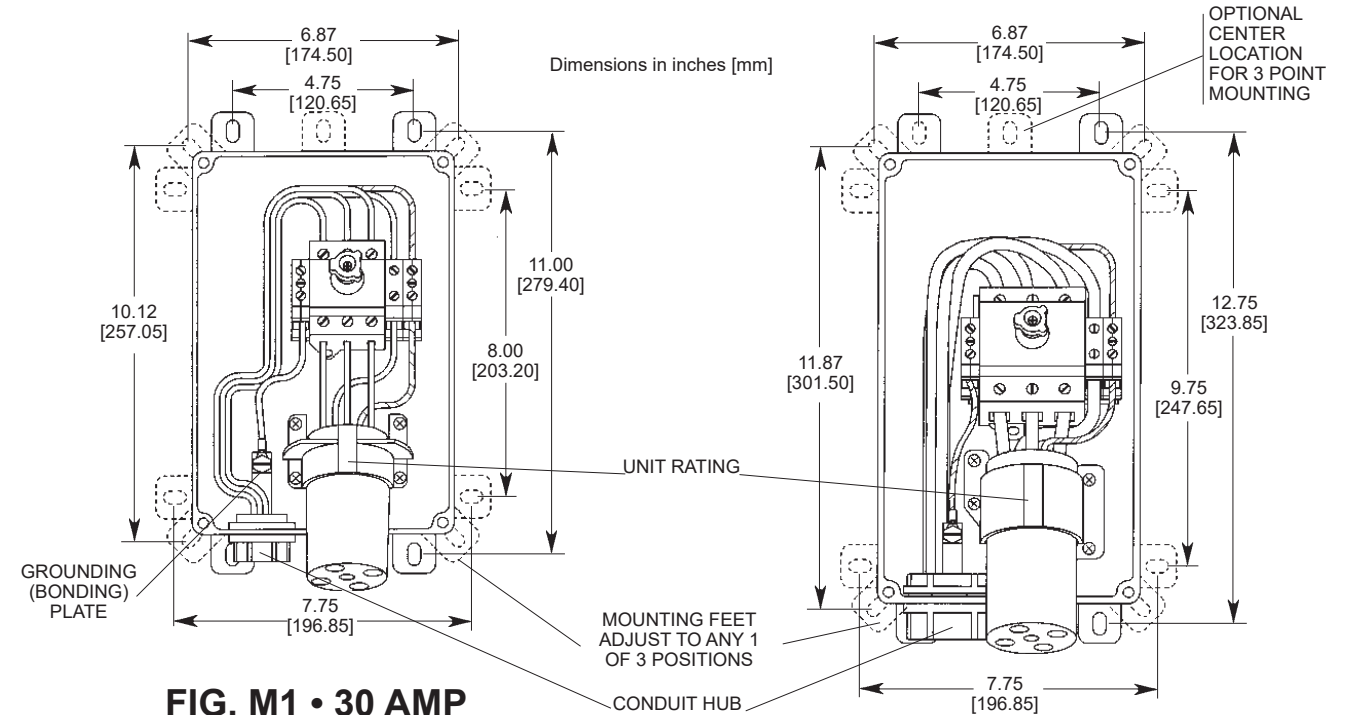

FIG. M1 • 30 AMP

FIG. M2 • 60 & 100 AMP

## INSTALLATION INSTRUCTIONS

### A. Mounting Instructions:

- This enclosure must always be mounted vertically with receptacle end down.
- This enclosure may be mounted for top, bottom or back conduit entrances. Bottom feed is recommended whenever possible. Figs M1 & M2. Back feed is permitted in Type 4X applications only. Fig. M4.
- For Type 4X and Type 12 applications, enclosure must be mounted by means of mounting feet. **DO NOT** drill, punch or nail mounting holes through the enclosure.
- Mount the feet to the enclosure using the screws provided. Tighten to 10-12 lb·in (1.2 - 1.4 N·m).
- Mounting feet will accept up to 5/16 inch (8 mm) diameter screws (not provided). Mounting pattern is shown in Fig. M1.
- Remove the four (4) cover mounting screws and remove cover. Switch handle must be in **“OFF”** position to remove cover.
- Drill or punch hole at the desired conduit entry location:
  - 1-3/8 inch (34.9 mm) diameter for 1 inch trade size conduit hub (30 Amp).
  - 1-3/4 inch (44.4 mm) diameter for a 1-1/4 inch trade size conduit hub (60 & 100 Amp).
 Molded drill spots on the outside top, bottom and back surface show the locations. Fig. M4.
- Use **ONLY** Listed/Certified conduit hub rated for Type 4X and Type 12 applications (one supplied).
- Install the conduit hub. Be sure that the “O” ring is properly seated in its groove.
- Install the grounding (bonding) plate under the conduit nut. Tighten nut securely for a watertight seal and grounding continuity.
- Any unused conduit entrance holes must be sealed with Listed/Certified closure plugs rated Type 4X and type 12. (Hubbell Cat. No. MICPK30 for 30A, Cat. No. MICPK60 for 60A and 100A).
- NOTE:** The metal closure plug must be grounded (bonded) back to the inside green & yellow grounding buss. Grounding (bonding) wire connection required.
- Use of user-installed conduit entrances above the switch are not recommended in applications where condensation may be present in the conduit (high humidity and extreme temperature change locations). When using the top feed conduit entrance, drip loops must always be formed as indicated in fig. M3.

# INSTALLATION INSTRUCTIONS (CONTINUED)

## B. Wiring Instructions

- Select conductors having 90°C or higher rated insulation and sufficient ampacity in accordance with the 60°C column (for 30 Amp and 60 Amp devices) or the 75°C column (for 100 Amp devices) of the National Electrical Code® Table 310-16 or Canadian Electrical Code Table 2.
- CAUTION: USE COPPER CONDUCTORS ONLY.**
- DO NOT TIN CONDUCTORS.
- Make sure the connected equipment rating does not exceed the rating of this device. See General Information #4 regarding overcurrent protection.
- Loose terminal screws. Insert conductors fully into proper terminals as identified in Table 1.  
For 16A, 20A, 30A and 32A use a 7/64 Hex Key.  
For 60A, 63A and 100A use a 5mm Hex Key.
- Strip conductor insulation ½ inch (13 mm).
- Select proper wiring diagram. Loosen terminal screws. Insert conductors fully into proper terminal.
- Tighten terminal screws to torque indicated in Table 2:
- TAKE CAUTION THAT THERE ARE NO STRAY WIRE STRANDS.**
- Tighten the grounding buss mounting screw to 10-12 lb•in (1.2-1.4 N•m).
- Reinstall the cover. The handle must be in the **OFF** position. Make sure the rope gasket is properly seated in the groove. Tighten the four cover screws to 10-12 lb•in (1.2-1.4 N•m).

	30A	60A	100A
Switch	#4 to #12 AWG	#2 to #10 AWG	#2 to #10 AWG
Ground	#6 to #16 AWG	#4 to #10 AWG	#4 to #10 AWG
Neutral	#8 to #22 AWG	#4 to #14 AWG	#1/0 to #14 AWG
Auxiliary contact	#14-18 AWG	#14-18 AWG	#14-18 AWG
Pilot		#12-18 AWG	P12-18 AWG

	30A	60 & 100A
Switch	27 lb•in (3.0 N•m)	50 lb•in (5.7 N•m)
Ground	16-18 lb•in (1.8-2.0 N•m)	22 lb•in (2.5 N•m)
Neutral	13-15 lb•in (1.5-1.7 N•m)	22 lb•in (2.5 N•m)
Auxiliary contact	10-12 lb•in (1.2-1.4 N•m)	10-12 lb•in (1.2-1.4 N•m)
Pilot		20 lb-in (2.5 N•m)

## THIS DEVICE CARRIES A MAXIMUM RATING OF:

CAT. NOS.	AMPS	RATING	HORSEPOWER [kW]	USE PIN & SLEEVE PLUG CAT. NO.	WIRE PER FIG.
BRY330MI4W	30	120VAC	2 [1.5]	HBL330P4W	W1
BRY330MI6W	30	240VAC	3 (208-240VAC) [2.25]	HBL330P6W	W2
BRY330MI7W	30	480VAC	7.5 [5.62]	HBL330P7W	W2
BRY430MI5W	30	600VAC 3Ø	20 [15]	HBL430P5W	W3
BRY430MI7W	30	480VAC 3Ø	15 [11.25]	HBL430P7W	W3
BRY430MI9W	30	240VAC 3Ø	7.5 [5.62]	HBL430P9W	W3
BRY430MI12W	30	120 / 240VAC	3 (208-240VAC, L-L) [2.25]	HBL430P12W	W4
BRY432MI3W	32	380VAC 3Ø 50 Hz 440VAC 3Ø 60Hz	15 (440VAC 3 Ø 60 Hz) [11.25]	HBL432P3W	W3
BRY530MI5W	30	347 / 600VAC 3ØY	20 [15]	HBL530P5W	W5
BRY530MI7W	30	277 / 480VAC 3ØY	15 [11.25]	HBL530P7W	W5
BRY530MI9W	30	120 / 208VAC 3ØY	5 [3.75]	HBL530P9W	W5
BRY360MI4W	60	120VAC	3 [1.5]	HBL360P4W	W1
BRY360MI6W	60	240VAC	7.5 (208-240VAC) [5.62]	HBL360P6W	W2
BRY360MI7W	60	480VAC	20 [15]	HBL360P7W	W2
BRY460MI5W+	60	600VAC 3Ø	40 [30]	HBL460P5W	W3
BRY460MI7W	60	480VAC 3Ø	30 [22.5]	HBL460P7W	W3
BRY460MI9W	60	240VAC 3Ø	15 [11.25]	HBL460P9W	W3
BRY460MI12W	60	120 / 240VAC	7.5 (208-240VAC, L-L) [5.62]	HBL460P12W	W4
BRY560MI5W	60	347 / 600VAC 3ØY	40 [30]	HBL560P5W	W5
BRY560MI7W	60	277 / 480VAC 3ØY	30 [22.5]	HBL560P7W	W5
BRY560MI9W	60	120 / 208VAC 3ØY	15 [11.25]	HBL560P9W	W5
--					
BRY3100MI6W	100	240VAC 208VAC	15 [11.25] 10 [7.5]	HBL3100P6W	W2
--					
BRY4100MI5W	100	600VAC 3Ø	50 [37.5]	HBL4100P5W	W3
BRY4100MI7W	100	480VAC 3Ø	50 [37.5]	HBL4100P7W	W3
BRY4100MI9W	100	240VAC 3Ø	25 [18.75]	HBL4100P9W	W3
BRY4100MI12W*	100	120/240VAC 208VAC	15 [11.25] 10 [11.25]	HBL4100P12W	W4
--					
BRY5100MI9W	100	120 / 208VAC 3ØY	20 [15]	HBL5100P9W	W5

\* Consult factory for availability

FIG. M3 • TOP FEED

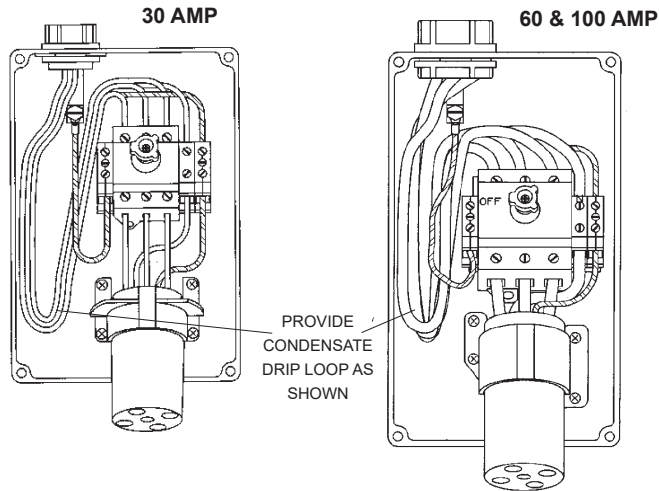

FIG. M4 • BACK FEED (TYPE 4X INSTALLATIONS ONLY)

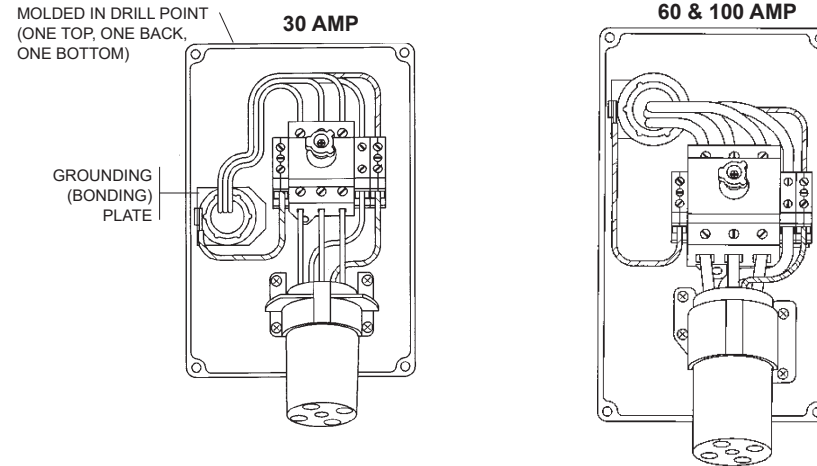

FIG. W1  
L W G

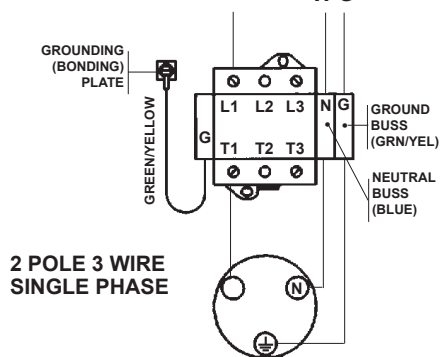

FIG. W2  
L L G

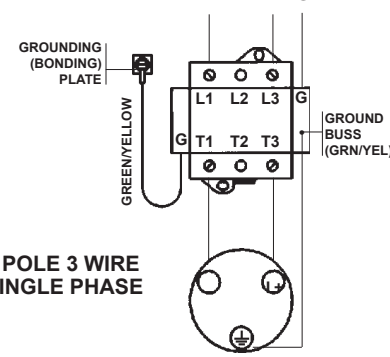

FIG. W3  
X Y Z G

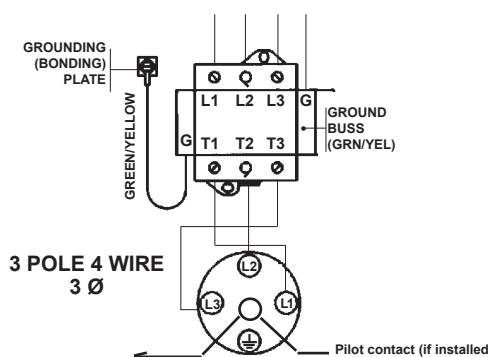

FIG. W4  
L L W G

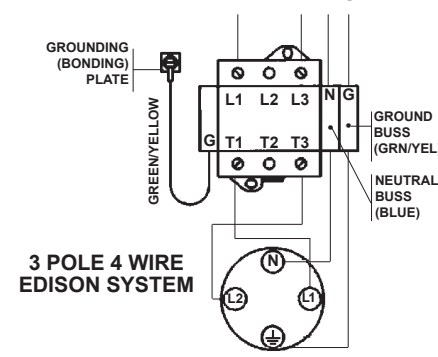

FIG. W5  
X Y Z W G

