

General Specifications	
Operating Temperature	0° to 60°C (32° to 140°F)
Storage Temperature	-20° to 70°C (-4° to 158°F)
Humidity	5 to 95% (non-condensing)
Environmental Air	No corrosive gases permitted
Vibration	IEC60068-2-6 (Test Fc)
Shock	IEC60068-2-27 (Test Ea)
Enclosure Type	Open Equipment
Agency Approvals	UL61010-2-201 file E139594, Canada & USA CE (Safety: EN61010-2-201 and Immunity: EN61131-2: 2007)
Noise Immunity	NEMA ICS3-304
EU Directive	See the "EU Directive" topic in the BRX Help File.
Weight	98g (3.5 oz)
Heat Dissipation	0.8W
Software Version Required	Do-more! Designer Version 2.3, or later.

*Meets EMC and Safety requirements. See the D.O.C. for details.

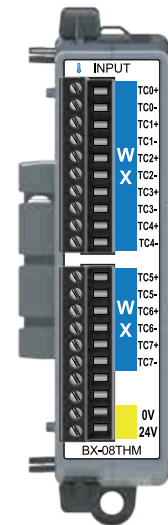

BX-08THM

Thermocouple Input Expansion Module

8-ch, 16-bit

I/O Terminal Blocks included. (See Terminal Block Connector Spec.table inside).
 Not compatible with the ZIPLink Wiring System

Terminal Block Connector Specifications			
Part Number	BX-RTB10 (Included)	BX-RTB10-1*	BX-RTB10-2*
Connector Type	Screw Type-90°	Spring Clamp Type-180°	Screw Type-180°
Pitch	3.81mm	3.81mm	3.81mm
Recommended Screw torque	<1.77 lb-in (0.2 N-m)	N/A	<1.77 lb-in (0.2 N-m)
Screwdriver Blade Width	2.5mm	2.5mm	2.5mm
Equiv. Dinkle part #	EC381V-10P-BK	ESC381V-10-BK	EC381F-10P-BK

*Sold separately

Thermocouple Input Specifications	
Input Channels	8 Differential
Commons	0
Input Impedance	Rev. A1: >5MΩ Rev. A2 or higher: >1MΩ
Resolution	16-bit, ±0.1°C or °F
Thermocouple Input Ranges	Type J -190° to 760°C (-310° to 1400°F) (Default) Type E -210° to 1000°C (-346° to 1832°F) Type K -150° to 1372°C (-238° to 2502°F) Type R 65° to 1768°C (149° to 3214°F) Type S 65° to 1768°C (149° to 3214°F) Type T -230° to 400°C (-382° to 752°F) Type B 529° to 1820°C (984° to 3308°F) Type N - 70° to 1300°C (-94° to 2372°F) Type C 65° to 2320°C (149° to 4208°F)
Cold Junction Compensation	Automatic
Thermocouple Linearization	Automatic
Accuracy vs. Temperature	±50PPM per °C (maximum)
Maximum Inaccuracy Temperature	±3°C maximum (excluding thermocouple error) (including temperature drift)
Linear Voltage Input Ranges	0-39mV ±78mV ±156mV ±39mV 0-156mV 0-1.25V
Maximum Inaccuracy Voltage	0.06% @25°C, 0.10% @ 0-60°C
Sample Duration Time	270ms
All Channel Update Rate	2.16 s
Open Circuit Detection Time	Within 2s
Maximum Ratings	Fault protected inputs to ±50V
Common Mode Range	0.6V
Common Mode Rejection	100dB @ DC and 130dB @ 60Hz
Conversion Method	Sigma-Delta
Backplane Power Consumption	0.1W
External DC Power Required	Class 2 or LPS power supply 24VDC (±20%) 25mA

WARNING: To minimize the risk of potential safety problems, you should follow all applicable local and national codes that regulate the installation and operation of your equipment. These codes vary from area to area and it is your responsibility to determine which codes should be followed, and to verify that the equipment, installation, and operation are in compliance with the latest revision of these codes.

Equipment damage or serious injury to personnel can result from the failure to follow all applicable codes and standards. We do not guarantee the products described in this publication are suitable for your particular application, nor do we assume any responsibility for your product design, installation, or operation.

If you have any questions concerning the installation or operation of this equipment, or if you need additional information, please call Technical Support at 770-844-4200.

This publication is based on information that was available at the time it was printed. At AutomationDirect.com® we constantly strive to improve our products and services, so we reserve the right to make changes to the products and/or publications at any time without notice and without any obligation. This publication may also discuss features that may not be available in certain revisions of the product.

Do-more BRX Manual available at
www.automationdirect.com/pn/doc/manual/BX-08THM



IMPORTANT!



Hot-Swapping Information
Note: This device cannot be Hot Swapped.

Document Name	Edition/Revision	Date
BX-08THM	1st Ed. RevA	2/4/2019

Copyright 2019, AutomationDirect.com Incorporated/All Rights Reserved Worldwide.

I/O Wiring

Terminal Block Input Wiring

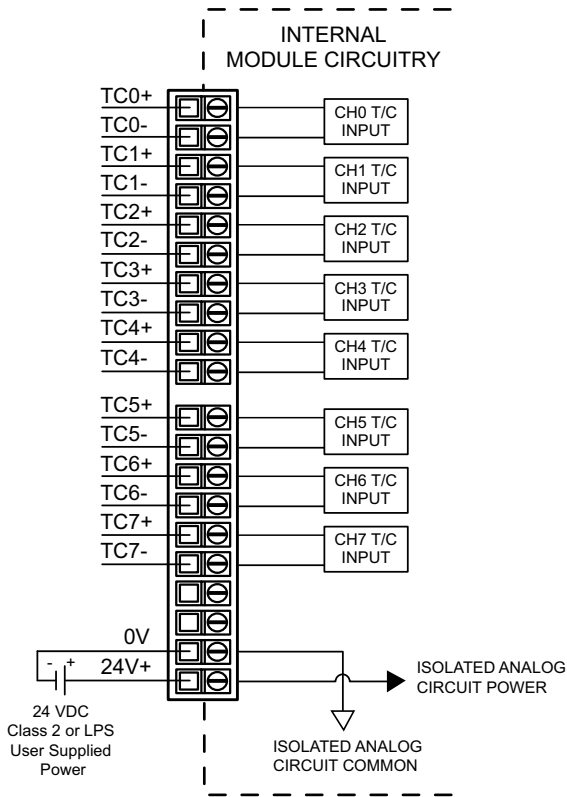

Module Installation

1 To Install, remove Connector Cover

To remove, depress disengagement plungers at top and bottom of module

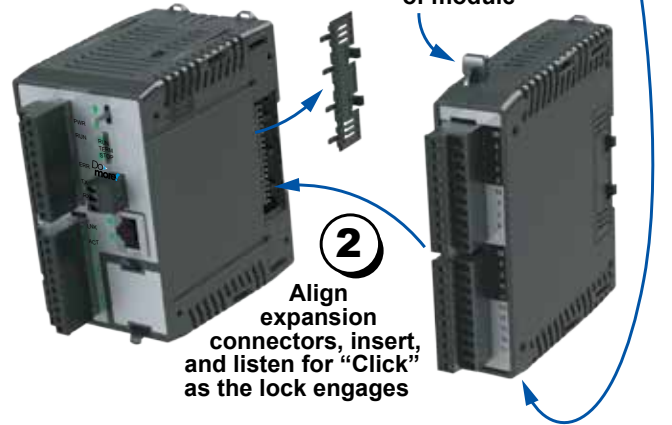

Dimensional Information

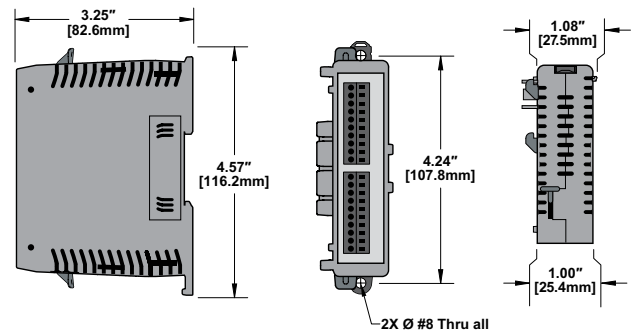

I/O Wiring

Thermocouple Input Circuits

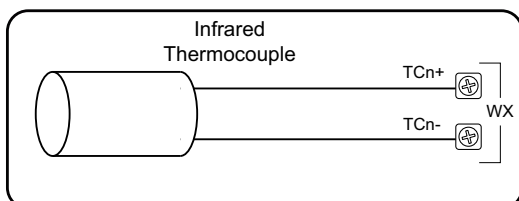
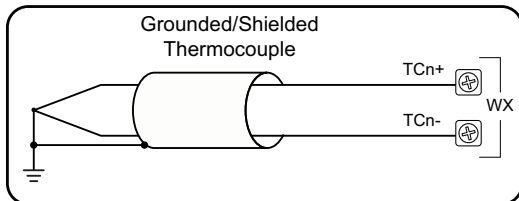
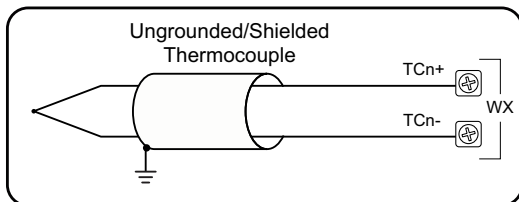

NOTE: Thermocouple extension wire and proper thermocouple terminal blocks must be used to extend thermocouples. AutomationDirect thermocouple wire is recommended.

I/O Wiring

Analog Voltage Input Circuits

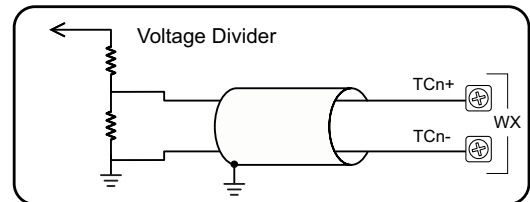
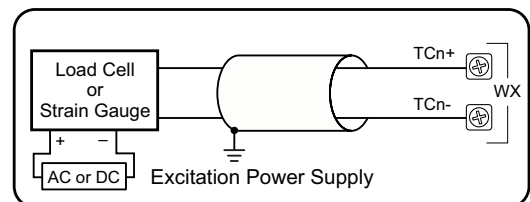
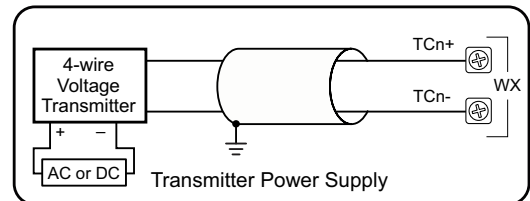

For maximum accuracy: Jumper unused inputs.

NOTE: Shield should be connected only at one end, to ground at the source device.