

MANUAL

UNINTERRUPTIBLE POWER SUPPLY



CHARGE AND CONTROL UNIT **PCC-0524-xxx-xx**

TABLE OF CONTENTS

| | |
|---|-----------|
| 1... ORDER DATA | 3 |
| 2. .. GENERAL INFORMATION..... | 4 |
| 2.1 Safety instructions | 4 |
| 2.2 Qualified personnel | 4 |
| 2.3 Intended use | 4 |
| 2.4 Disclaimer..... | 4 |
| 3. .. PRODUCT DESCRIPTION | 6 |
| 3.1 Block diagram | 7 |
| 3.2 Dimensioning..... | 8 |
| 3.3 Assembly..... | 9 |
| 3.4 Connections and signaling PCC-0524-xxx-00..... | 11 |
| 3.5 Connections and signaling PCC-0524-xxx-0U | 12 |
| 4. .. Commissioning | 13 |
| 4.1 Operating States / Signaling | 13 |
| 4.2 Battery tests | 16 |
| 4.3 Battery charging (PCC-0524-xxx-0U) | 17 |
| 4.4 Battery operation | 20 |
| 4.5 Buffer times of the battery modules..... | 23 |
| 4.6 Derating | 23 |
| 5. .. MAINTENANCE | 24 |
| 5.1 Service life of the battery modules | 24 |
| 5.2 Storage of the battery modules..... | 24 |
| 6. .. USV FIRMWARE UPDATE..... | 24 |

1. ORDER DATA

The following table shows the ordering data for the charging and control unit and the battery modules.

Table 1: Order numbers

| CHARGING AND CONTROL UNIT | | | |
|---------------------------|---------------|----------------|------------------|
| Variant | Input voltage | Output current | Interface |
| PC-0524-400-0 | 24 Vdc | 40 A | Yes (USB) |
| PCC-0524-100-00 | 24 Vdc | 10 A | No |
| PCC-0524-100-0U | 24 Vdc | 10 A | Yes (USB) |
| PCC-0524-200-00 | 24 Vdc | 20 A | No |
| PCC-0524-200-2U | 24 Vdc | 20 A | Yes (USB) |
| BATTERY MODULE | | | |
| Variant | Input voltage | Output current | Nominal capacity |
| PVAF 24/0,8 Ah | 24 Vdc | max. 5 A | 0,8 Ah |
| PVAF 24/1,2 Ah | 24 Vdc | max. 7,5 A | 1,2 Ah |
| PVAF 24/7 Ah | 24 Vdc | max. 40 A | 7 Ah |
| PVAF 24/12 Ah | 24 Vdc | max. 40 A | 12 Ah |
| PVA 24/3,2 Ah | 24 Vdc | max. 20 A | 3,2 Ah |
| PVA 24/7 Ah | 24 Vdc | max. 40 A | 7 Ah |
| PVA 24/12 Ah | 24 Vdc | max. 40 A | 12 Ah |
| PST-0124-032-00 | 24 Vdc | max. 20 A | 3,2 Ah |
| PST-0124-070-00 | 24 Vdc | max. 40 A | 7 Ah |
| PST-0124-070-10 | 24 Vdc | max. 40 A | 7 Ah |
| PST-0124-120-00 | 24 Vdc | max. 40 A | 12 Ah |
| PST-0124-120-10 | 24 Vdc | max. 40 A | 12 Ah |
| PST-0124-180-00 | 24 Vdc | max. 40 A | 18 Ah |
| PST-0124-400-00 | 24 Vdc | max. 40 A | 40 Ah |

UPS-Control Software

Visualization and configuration software for the charging and control unit, free download at www.block.eu For the display and individual setting of the charging and control unit.

2. GENERAL INFORMATION

2.1 Safety instructions

Please read these warnings and safety instructions carefully before operating the appliance. The appliance may only be installed by skilled and qualified personnel. In the event of malfunctions or damage, switch off the supply voltage immediately and send the device to BLOCK Transformatoren-Elektronik GmbH for inspection. The device does not contain any service parts. If an internal fuse blows, there is most likely an internal defect in the appliance. The data provided is for product description purposes only and should not be construed as guaranteed characteristics in the legal sense.

2.2 Qualified personnel

The product associated with this documentation may only be handled by qualified personnel in compliance with the documentation associated with the respective task, in particular the safety instructions and warnings contained therein. Qualified personnel can ensure, on the basis of their training and experience, that the use of the described product complies with all safety requirements and the applicable provisions, regulations, standards and laws.

2.3 Intended use

This device is designed for installation in a housing and is suitable for use in general electronic devices, such as industrial control systems, office equipment, communication devices or measuring devices. Do not use this device in control systems of airplanes, trains or nuclear facilities, where a malfunction could lead to serious injury or danger to life.

2.4 Disclaimer

The content of this publication has been checked with the utmost care to ensure that it corresponds to the hardware and software described. Nevertheless, there may be discrepancies between the product and the documentation. Deviations may also occur due to the continuous further development of the product. For this reason, we cannot guarantee complete conformity. Should this documentation contain errors, we reserve the right to make any necessary corrections without prior notice.



CAUTION

Before carrying out installation, maintenance or modification work, switch off the input voltage and secure it against unintentional reconnection.



CAUTION

Do not modify or attempt to repair the appliance. Do not open the device!



CAUTION

Prevent the ingress of foreign objects such as paper clips and metal parts.



CAUTION

Do not operate the appliance in a damp environment or in an environment where condensation or condensation is to be expected.



CAUTION

Do not touch the housing during operation or shortly after switching off.
Hot surfaces can cause injuries.

3. PRODUCT DESCRIPTION

In combination with up to three battery modules and a suitable external power supply, the charging and control unit forms an uninterruptible power supply (UPS). This UPS protects the system and sensitive data from power failures and voltage fluctuations. Depending on the application, up to 20 A is available without interruption for 24 V networks. The charging and control unit ensures a reliable supply of power to industrial PCs at all times.

The intelligent battery management of the UPS combines short charging times with optimized charge management for the longest possible service life of the battery modules. In addition, permanent monitoring of the battery modules is available, which provides an early warning if the remaining service life of the battery modules is low.

A special feature of the device is the setting option via the rotary switch on the front. This rotary switch makes it possible to select a fixed buffer time, individual configuration via the interface (only the USB versions in conjunction with the UPS-Control software) or the IPC shutdown mode.

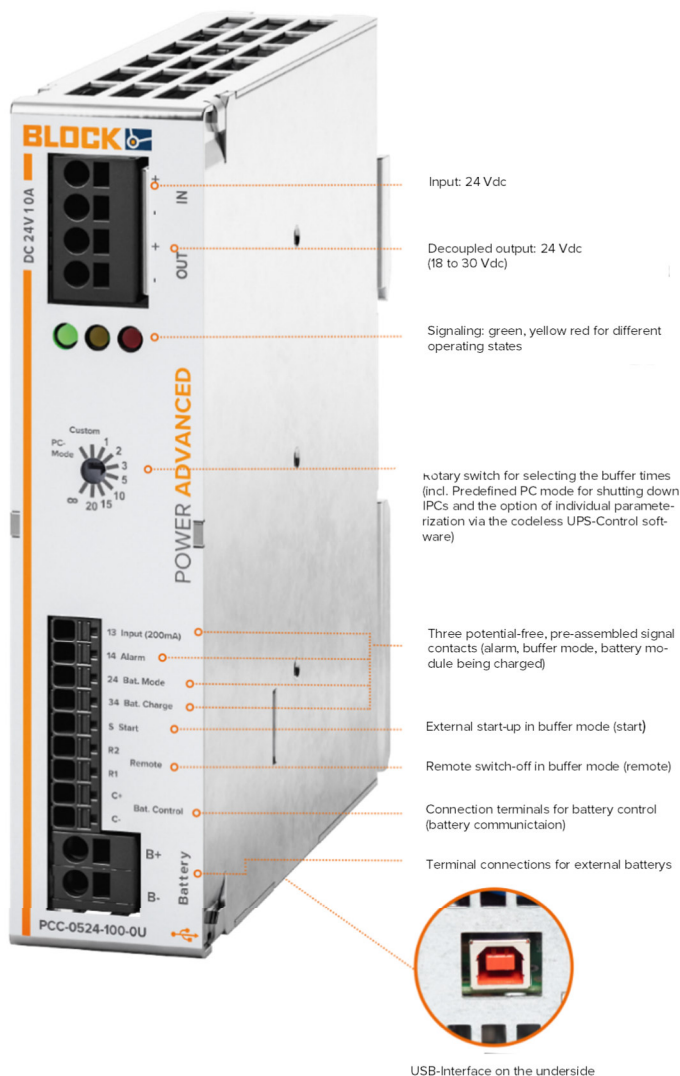

Figure 1: PCC-0524-xxx-0U

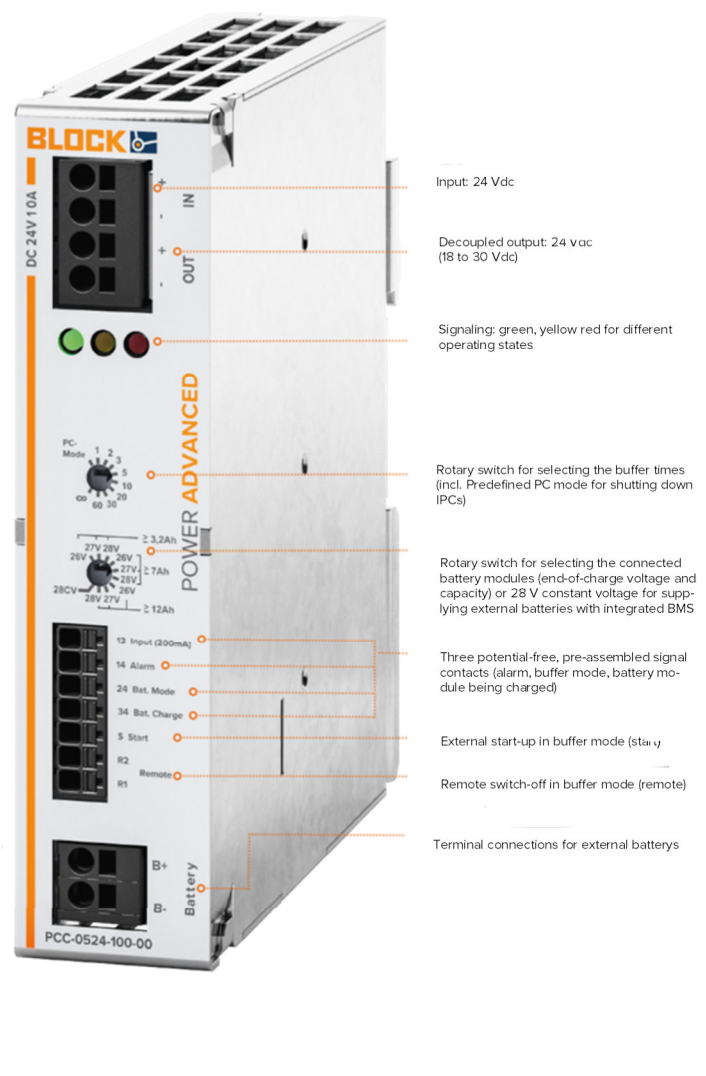

Figure 2: PCC-0524-xxx-00

3.1 Block diagram

The following block diagram shows a wiring example.

To ensure good communication between the battery modules and the charging and control unit, interface, control and signal cables should be < 3 meters.

In addition, care must be taken not to lay the control cable parallel to power cables, as otherwise communication interference is to be expected.

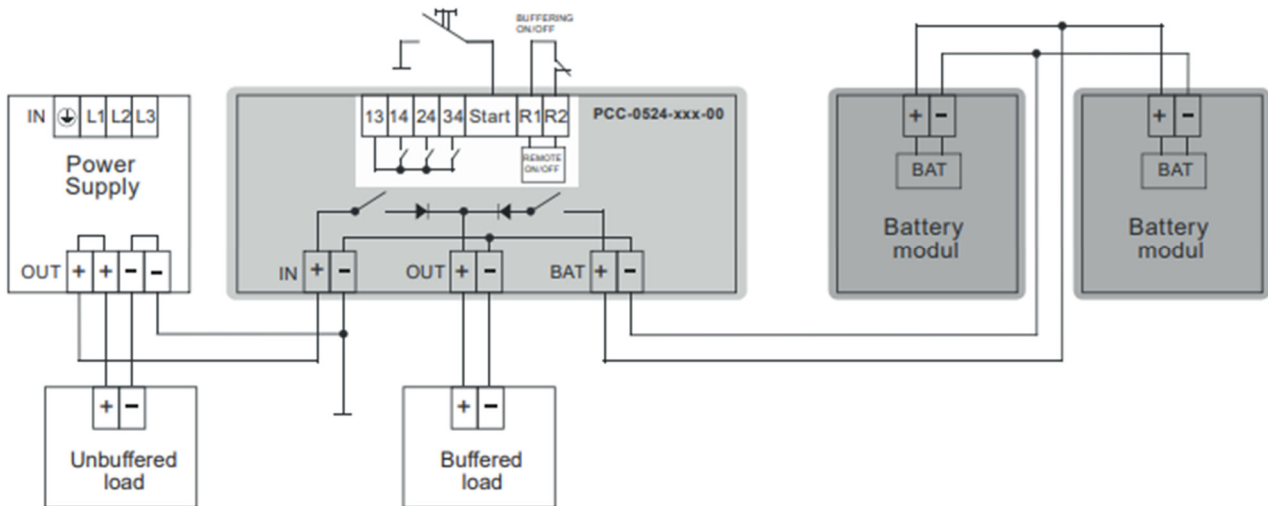

Figure 3: Wiring block diagram - PCC-0524-xxx-00

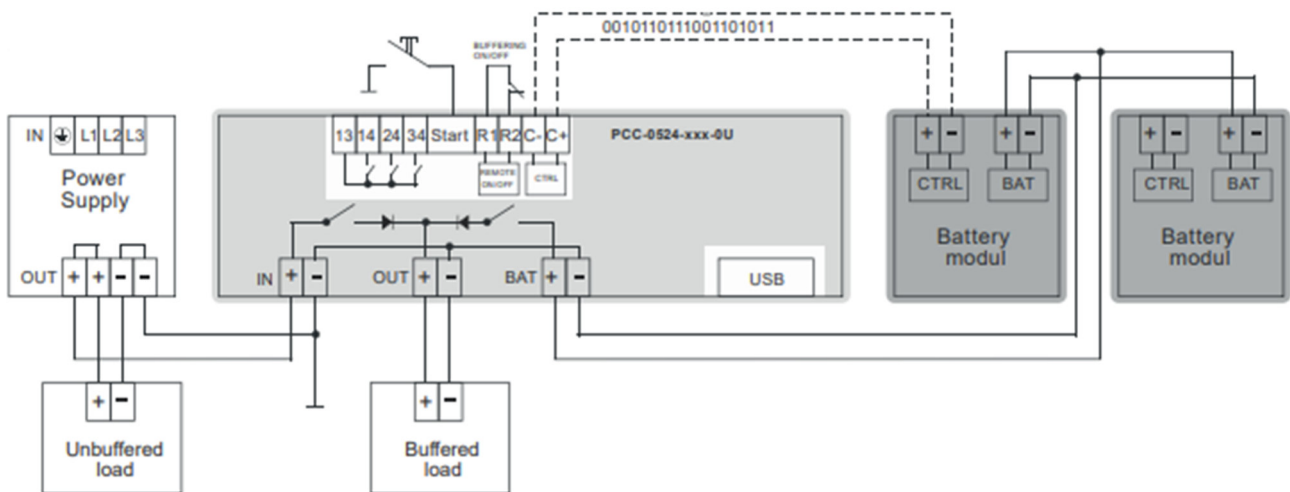

Figure 4: Wiring block diagram - PCC-0524-xxx-0U

In order to maintain the maximum buffer time, up to 3 battery modules can be connected in parallel (see chapter 4.5). If several battery modules are used, the control cable must only be connected to one battery module.

3.2 Dimensioning

The dimensions of the loading and control units are shown in Figures 5 & 6.

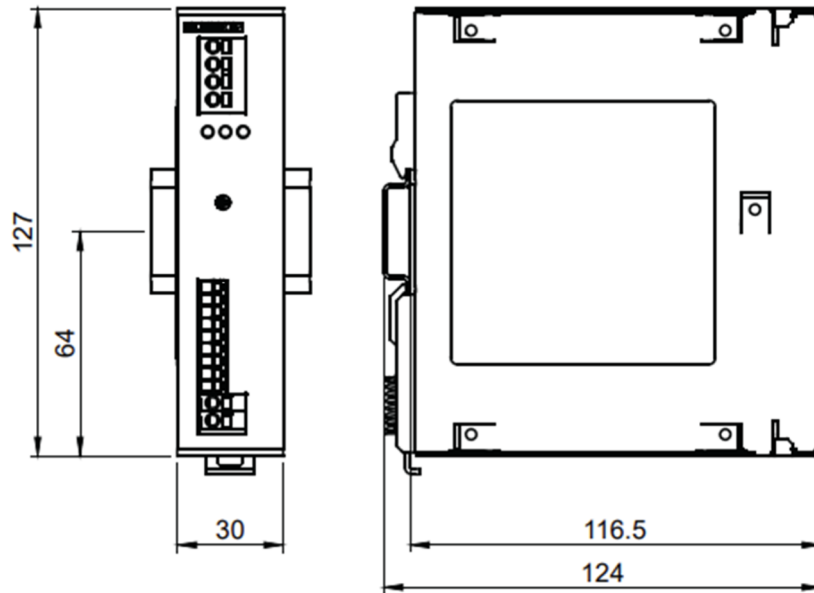

Figure 5: Dimensioning of the PCC-0524-100-xx

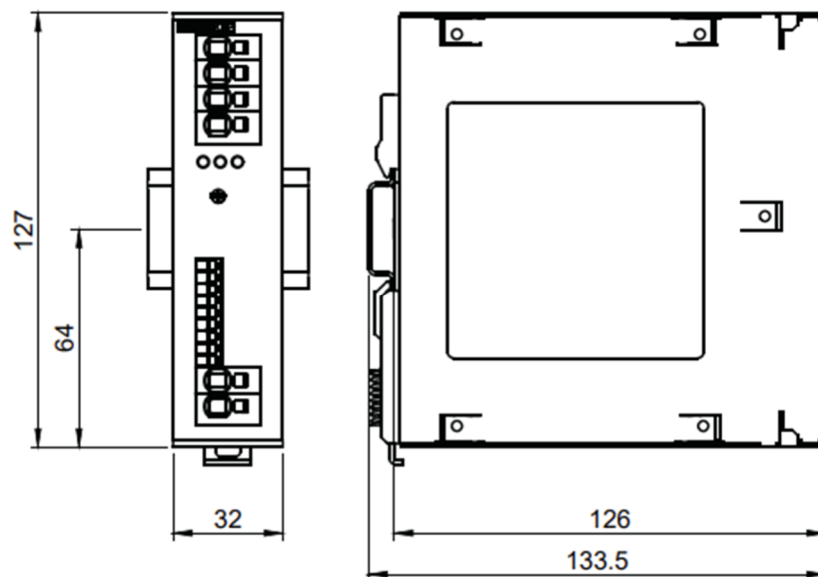

Figure 6: Dimensioning of the PCC-0524-200-xx

The dimensions of the corresponding battery modules can be found in the operating instructions for the battery modules.

3.3 Assembly

The charging and control unit can be mounted on the mounting rail without tools.

To do this, first turn the front of the device slightly upwards and place it on the top-hat rail. Make sure that the device is pushed down as far as it will go. If the device is seated on the top-hat rail, the underside is pressed against the mounting rail until it locks into the top-hat rail (followed by a "click" sound). To check, gently shake the device again to ensure that it is properly locked.

A standard tool, such as a slotted screwdriver, is required for removal. The device can be detached from the top-hat rail by lifting the underside of the device and pressing down on the fastening.

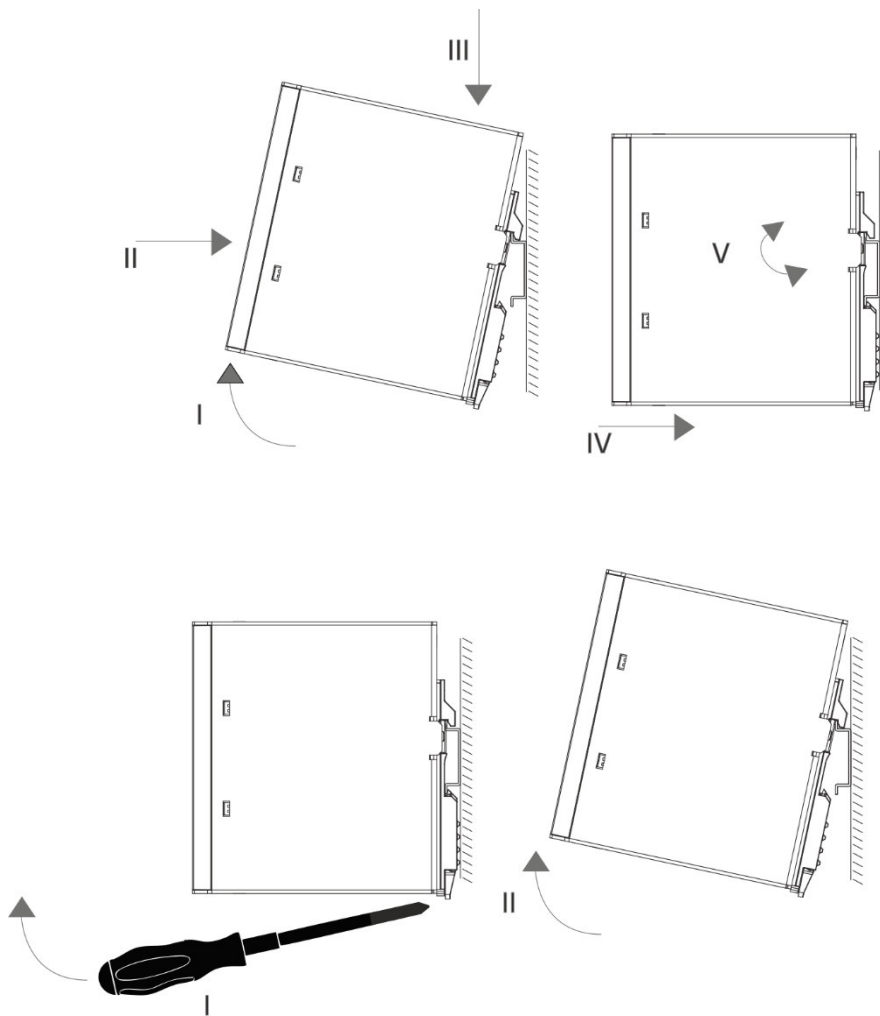

Figure 7: Assembly

To ensure cooling by natural convection, a distance of at least 40 mm from neighboring appliances must be maintained at the top and bottom. Direct side mounting of other appliances is permitted.

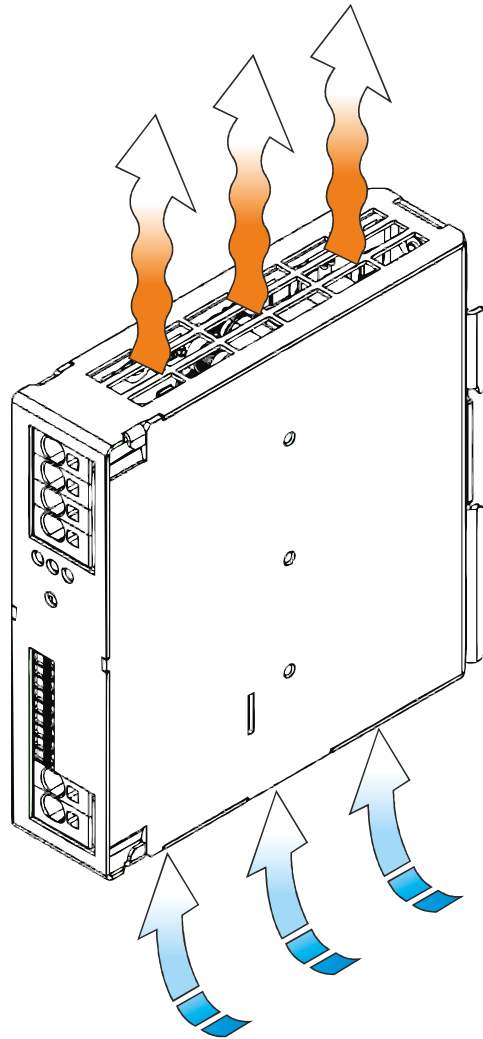

Figure 8: Convection cooling



ATTENTION

The device may only be mounted horizontally. Any other installation is not permitted.

3.4 Connections and signaling PCC-0524-xxx-00

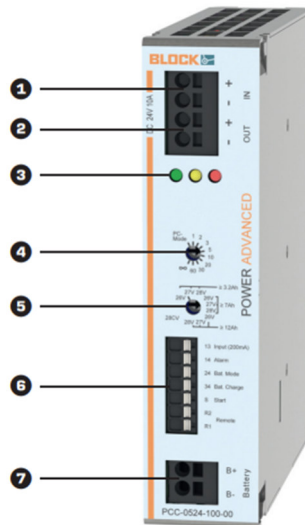

| Nr. | Function | Note |
|-----|--|---|
| 1 | Input terminals of the power supply | Push-In, max. 2,5 mm ² (PCC-0524-100-00) Push-In, max. 6 mm ² (PCC-0524-200-00) |
| 2 | Output terminals of the power supply | Push-In, max. 2,5 mm ² (PCC-0524-100-00) Push-In, max. 6 mm ² (PCC-0524-200-00) |
| 3 | Signal lights | LED red: Alarm LED yellow: Bat. charge /Bat. mode LED green: DC OK |
| 4 | Rotary switch for buffer time setting | Buffer time in minutes (1-60) IPC mode (PC mode) Maximum time (∞) |
| 5 | Setting the charge controller (end-of-charge voltage / charging current) | 3.2Ah, 7Ah or 12Ah battery module |
| 6 | Signal and control contacts | 13: Floating collective input for signal outputs 14/24/34 14: Alarm (active low) 24: Battery mode (active high) 34: Battery Charge (active high) Start: Start-up in battery mode R1/R2: Remote shutdown in buffer operation 0.2-1.5 mm ² (24...12 AWG) |
| 7 | Battery connection terminals | Push-In, max. 2,5 mm ² (PCC-0524-100-00) Push-In, max. 6 mm ² (PCC-0524-200-00) |

Table 1: Connections and signaling of the PCC-0524-xxx-00

3.5 Connections and signaling PCC-0524-xxx-0U

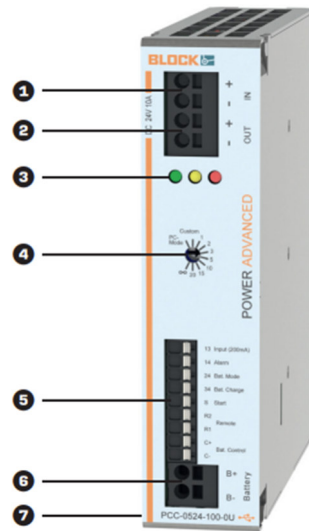

| Nr. | Function | Note |
|-----|--|--|
| 1 | Input terminals of the power supply | Push-In, max. 2,5 mm ² (PCC-0524-100-0U) Push-In, max. 6 mm ² (PCC-0524-200-0U) |
| 2 | Output terminals of the power supply | Push-In, max. 2,5 mm ² (PCC-0524-100-0U) Push-In, max. 6 mm ² (PCC-0524-200-0U) |
| 3 | Signal lights | LED red: Alarm LED yellow: Bat. charge /Bat. mode LED green: DC OK |
| 4 | Rotary switch for buffer time setting | Buffer time in minutes (1-20) IPC mode (PC mode) Maximum time (∞) Individually via configuration software setting (Custom) |
| 5 | Signal- and control contacts | 13: Potential-free collective input for signal outputs 14/24/34 14: Alarm (default = active low) 24: Battery Mode (default = active high) 34: Batterie Charge (default = active high) Start: Run-up in battery option R1/R2: Remot shutdown in buffer operation C+/C-: Control lines for „Battery Control“ |
| 6 | Battery terminal connections | Push-In, max. 2,5 mm ² (PCC-0524-100-0U) Push-In, max. 6 mm ² (PCC-0524-200-0U) |
| 7 | USB-socket on the underside for connection to the PC | USB 2.0 / Potentially separated |

Figure 2: Connections and Signaling of the PCC-0524-xxx-0U

4. Commissioning

After connecting battery modules with „Battery Control“ to the PCC-0524-xxx-0U, they are automatically recognized, provided the control line „C+/C-“, for communication between the modules is connected with the correct polarity.



NOTE

The cable to the battery must be protected against overload according to the wire cross-section.



NOTE

For optimal supply of the battery modules, operation with connected control lines and battery modules with "Battery Control" is recommended. The polarity must be observed. Before supplying power to the module, the battery modules should be fully connected to avoid incorrect signaling..

4.1 Operating States / Signaling

The charging and control unit can signal current operating states, warnings, and faults. For function monitoring, three control lights (LEDs) and three potential-free contacts are available.

At delivery, the signal outputs are configured as follows::

Table 3: Configured Signal Outputs

| State | Signal output | Function |
|---|---------------|--------------|
| No battery operation possible or battery replacement recommended or output turned off | 13/14 | Not inverted |
| UPS is operating in battery mode | 13/24 | Inverted |
| Battery module is charging | 13/34 | Inverted |

The charging and control unit is capable of detecting multiple events, which can be individually linked to the three signal outputs via the configuration and management software UPS-Control. The logic (inverted / not inverted or low-resistance / high-resistance) can also be changed if needed.

Table 4: Detectable events

| Nr. | Description |
|-----|--|
| 1 | Buffer mode |
| 2 | No buffer operation possible: Presence test negative or connection for remote shutdown (remote input) not available |
| 3 | Battery voltage very low < 20,4 V |
| 4 | Battery charge < 85 % |
| 5 | Battery replacement recommended |
| 6 | Output is turned off |
| 7 | Fuse-Mode |
| 8 | Hiccup-Mode |
| 9 | Output current to high |
| 10 | Automatic charging control |
| 11 | System error |
| 12 | Safety shutdown |

The charging and control unit has three overload behaviors that can be selected.

Hiccup Mode

The output cannot be started within 5 seconds due to a short circuit or persistent overload.

Three start attempts are made with a waiting time of 20 seconds each. If no restart has occurred so far, a 5-minute pause will be performed before the next start attempt.

Fuse Mode

The output cannot be started within 5 seconds due to a short circuit or persistent overload. The output remains turned off.

To exit Fuse Mode, the "Reset Fuse Mode" button must be pressed. This button appears in the UPS-Control software under "Overload Behavior" once Fuse Mode is activated.

If the restart attempt was unsuccessful, it can only be tried again after a waiting time of 20 seconds.

Power Boost/Top Boost

In the event of an overload, the charging and control unit allows temporarily increased loads to be supplied with Power Boost.

PCC-0524-100-xx

- PowerBoost : 15A für 5S
- TopBoost : 25A für 55mS

PCC-0524-200-xx

- PowerBoost : 30A für 5S
- TopBoost : 50A für 55mS

The Power Boost in mains operation must be supported by the upstream power supply.

NOTE



In the delivery state, the Hiccup Mode is activated. To enable Fuse Mode or Power Boost, the UPS-Control software is required.
In the UPS-Control software, under the "Parameters" and "Overload Behavior" tabs, Fuse Mode or Power Boost can be selected.

The LED status indicators also allow the operating state of the charging and control unit to be viewed. The light signals have the following meaning.

Graphic 1: Signaling via LED status indicators

| Shutdown_Mode Output off | Net_Mode Output on | Charging_Mode Output off | Buffer/IPC Mode Output on | Safety_Mode Output off | Over current_Mode Output off |
|-----------------------------|---|-----------------------------|------------------------------|------------------------------|---------------------------------|
| | | | Storage Voltage >20,5V | Input Voltage is to high | Fuse |
| | SOC < 85% | SOC < 85% | Storage Voltage <20,5V | Input Voltage is to low | Hiccup |
| | Bridge or Storage not Available | | Storage Voltage <19V | | |
| | Bridge or Storage not Available and SOC < 85% | | Storage Voltage <18V | | |
| | Exchange Storage (Lifetime >260) | | | | |
| | SOC <85% / Exchange Storage (Lifetime >260) | | | | |

Legende

Fast blink

Slow blink

Shutdown_Mode: In this mode, everything on the UPS is turned off. However, the states of the switched relays are maintained for a maximum of 1 hour and do not drop.

Net_Mode: The UPS is in mains mode. DC-In is OK. The load is being supplied with power, and the battery module is being charged simultaneously..

Charging_Mode: DC-In OK, the output of the UPS is turned off, and the exclusive charging mode is active. This mode can only be activated via the UPS-Control in the USB variant.

Buffer/IPC Mode: DC-In not OK, the power supply is now provided by the connected battery module. The backup time can be adjusted via the rotary switch on the front or through the IPC.

Safety_Mode: Due to a faulty input voltage, the UPS switches to Safety Mode.

Over_current_Mode: Due to a short circuit, the UPS switches to the overcurrent mode. Safety shutdown.

The output is turned off to protect the charging and control unit and the load. If a voltage that is too low (< 18 V in 24 V operation) or too high (> 30 V in 24 V operation) is detected during the startup process, the system waits for the return of the nominal voltage within a 60-second waiting period. If no voltage change is detected after the waiting time, the system switches to shutdown mode.

Shutdown Modus

The shutdown mode has been activated due to the safety shutdown. If the mains voltage does not reach the nominal voltage after three cycles, the waiting time in shutdown mode will be extended to 120 seconds.

The buffer operation has been ended (backup time has expired or buffer operation was terminated due to deep discharge protection) and the mains voltage is not within the nominal range. The LED signals this state for an additional 5 seconds, after which the system will be turned off.

Start from the battery

If an external start of the system is required without an incoming power supply, the charging and control unit allows startup from the connected battery. By briefly applying the ground of the battery or power supply to the „Start“ terminal, the charging and control unit is started in buffer operation, and the connected load is fully supplied by the connected batteries.

Once the system has started up and the mains voltage is applied, the charging and control unit automatically switches to normal operation.



ATTENTION

Applying the ground of the battery or power supply to the "Start" terminal must only be done briefly (pulse), as continuously applying 0V to the "Start" terminal will bypass the safety shutdown.



NOTE

In the delivery state, the states of the LED indicators are also signaled via the signal outputs. If a custom configuration of the signal outputs is made, signal states may differ from the LED display. Ensure that only meaningful combinations are signaled.

4.2 Battery tests

The charging and control unit performs different battery module checks depending on the operating state. If irregularities are detected, corresponding warnings or faults are generated.

Charging status (Only for PCC-0524-xxx-0U)

In normal operation, the battery module is charged. During charging, the charging status is checked every 60 seconds.

If the battery modules are less than 85% charged, the state "Battery is charging" is signaled. The yellow LED lights up, and the signal output "Bat. Charge" is activated (only in the delivery state).

Presence test

The presence test is used to detect a correctly connected and functional battery module and is carried out during normal operation. During the presence test, the battery modules are briefly subjected to a slight load to ensure that the battery module is connected correctly, that the batteries are functional and that the fuse is intact.

The presence test is carried out every 30 seconds in normal operation with a charging current < 1 A and every 180 seconds with a charging current > 1 A. In the event of a negative result, the test is repeated cyclically every 15 seconds.

If the presence test returns a negative result, the fault "no buffer operation possible" is signaled. The red LED lights up and the "Alarm" signal output is activated (only in the as-delivered state).

**NOTE**

For battery modules without "Bat. Control", only the presence test is carried out.

**NOTE**

The presence test is carried out every 60s

Quality test

Batteries have a limited service life, which can be between < 1 -15 years depending on the model and the ambient temperature.

The remaining service life of the batteries is calculated dynamically depending on the ambient temperature in the battery module, provided that both "Bat. control" control lines are connected correctly. This check is carried out every 10 minutes during normal operation. If the quality test produces a negative result, the warning "Battery replacement recommended" is generated. The red LED flashes and the "Alarm" signal output is activated.

**NOTE**

It is recommended that the battery module is replaced as soon as possible after the warning as soon as possible in order to maintain safe buffer operation.

4.3 Battery charging (PCC-0524-xxx-0U)

The intelligent battery management enables dynamic adjustments, such as setting the optimum charging current or a temperature-dependent charging voltage for all detected battery modules with "Battery Control".

Temperature-dependent charging voltage

By measuring the actual temperature directly in the battery module with "Battery Control", charging is temperature-compensated. This extends the service life of the installed batteries in the long term. Further settings of charging parameters are not necessary due to the automatic detection.

With the PCC-0524-xxx-00, the temperature is measured via an internal NTC resistor. Although this is not quite as accurate as the USB version, it contributes to safe charging management.

In addition, the PCC-0524 has a safety shutdown due to the internal NTC resistor mentioned above.

The charging control is based on an IU charging characteristic. This is a 2-stage charging process that is represented as follows.

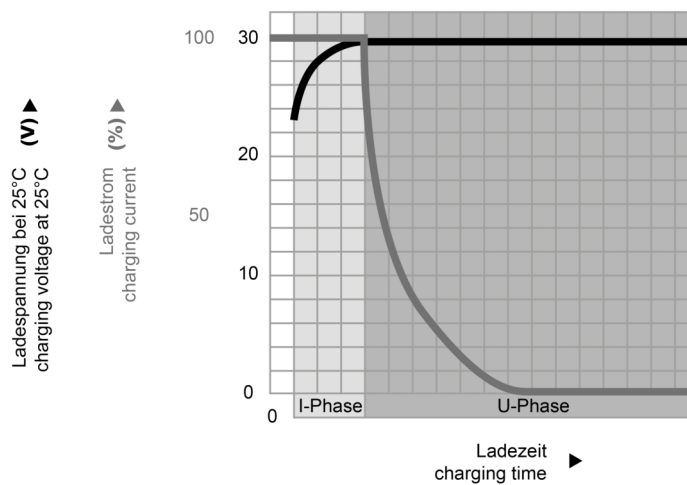

Figure 9: Charging characteristics

| Level | Name | Description |
|-------|------------------------------------|---|
| 1 | Main charge | Constant current charging phase Initial charging current |
| 2 | Equalizing charge / trickle charge | Constant voltage charging phase Equalizing end-of-charge voltage Float charge voltage |

If the communication cable between the charging and control unit and the battery module is interrupted, the temperature recorded in the charging and control unit is used as a substitute to ensure temperature compensation.



NOTE

Temperature compensation for battery modules without "Battery Control" is handled in the same way as for a communication interruption.

If battery modules without communication are used, the adaptation of general charging parameters must be individually checked and ensured depending on the battery module used.

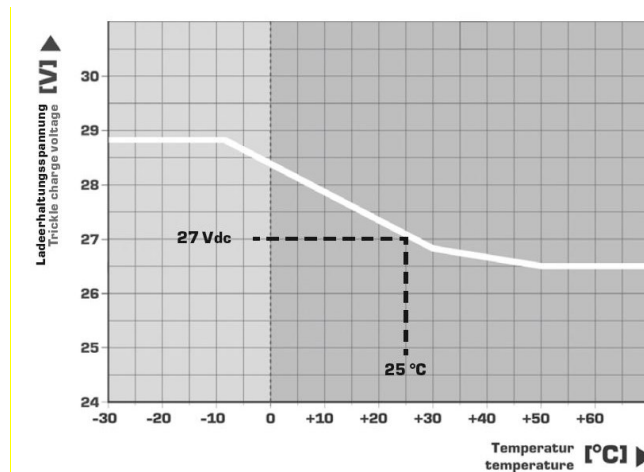

Figure 10: Compensation charging curve

Automatic temperature compensation can be deactivated at any time via the configuration software. A fixed value for the float charge voltage can be stored individually.

NOTE



To enable temperature-dependent charging even for battery modules without "Battery Control", it is possible to attach a separate temperature sensor to the battery module and connect it to the charging and control unit via the "C+" and "C-" terminals. To obtain accurate measurement results, it is necessary to use only the following temperature sensor: EPCOS B57164K0472

Factory charging settings

Once the battery modules with "Battery Control" have been detected, the following charging settings are adopted at the factory. Battery modules without "Battery Control" are charged at the factory with a voltage of 27.4 V in 24 V mode and a charging current of 0.8 A.

Table 2: Factory charging setting

| Variant | Charging voltage | Charging current |
|----------------|------------------|------------------|
| PVAF 24/0,8Ah | 28,8 V | 0,2 A |
| PVAF 24/1,2 Ah | 28,8 V | 0,3 A |
| PVAF 24/7 Ah | 28,8 V | 1,8 A |
| PVAF 24/12 Ah | 28,8 V | 3,0 A |
| PVA 24/3,2 Ah | 28,8 V | 0,8 A |
| PVA 24/7 Ah | 28,8 V | 1,8 A |
| PVA 24/12 Ah | 28,8 V | 3,0 A |

NOTE



The configuration software can be used to set an individual charging current as a fixed fixed setpoint value at any time, regardless of the battery module used.

4.4 Battery operation

If the mains voltage fails, the system switches to buffer mode without interruption. The energy required to maintain the DC 24V supply voltage is taken from the battery module. The level of the output voltage is directly dependent on the state of charge and the capacity of the batteries.

Buffer operation is signaled by the slow flashing of the yellow LED (approx. 2 Hz). This event is linked to the "Bat. mode" signal output ex works.

The charging and control unit supports both the maintenance of the supply voltage for a configurable time and the controlled shutdown and restart of an industrial PC (IPC) - see chapter "Buffer operation in IPC mode".

For the software-based shutdown of an IPC, the rotary switch must be set to "PC mode" or the setting can be made via the "UPS Control" Windows software. If the charging and control unit is connected to the IPC, the cyclically sent data from the UPS triggers the shutdown after an adjustable time.



ATTENTION

It is not permitted to connect a 12 V battery module in 24 V operation. This can lead to destruction of the battery module.

Switch-on threshold for buffer operation

If the input voltage drops below the switch-on threshold, the energy from the battery modules is provided without interruption. The charging and control unit is then in buffer mode.

The switch-on threshold is preconfigured to 22 V at the factory. The switch-on threshold can be changed using the UPS Control configuration software.

- 21 V - 26 V adjustable (24 V operation)

Buffer operation with adjustable buffer time

The module is preconfigured at the factory for maximum (unlimited) buffer time. In this configuration, the entire energy of the battery module is used to maintain the DC 24 V supply voltage. The buffer time can be set using the selector switch.

- 1 ... 20 minutes
- Unlimited until deep discharge protection ends buffer operation
- Individual time via configuration software
- PC mode, see chapter "Buffer operation in IPC mode"

Buffer operation in ∞ mode

If ∞ mode is selected, buffering of at least 8 hours is guaranteed in accordance with VDE-AR-N 4110.

Buffer operation in IPC mode

In IPC mode, the UPS module operates according to a time sequence that is used for the controlled shutdown and reliable restart of an IPC. Changeable times can only be adjusted via the configuration software. The signal to shut down the IPC is transmitted via the potential-free signaling contact selected in the UPS Control.

The time sequence of "delay time", "switch-off time" and "waiting time" is defined in each case. The option of switching off the output despite network recovery during buffer operation means that an IPC can be reliably restarted after shutdown.



NOTE

To activate IPC mode, the rotary switch on the charging and control unit must be set to PC mode. Only then will the IPC configuration appear in the UPS Control software.

Delay time

If the mains voltage is restored during the set delay time in buffer mode, the output of the charging and control unit is not switched off.

The "Bat. mode" signal output (can be configured via the configuration software) remains in an inactive state so that no signal is generated to shut down the IPC.

If the input network only returns after the set delay time has elapsed, the output voltage and signal output are switched according to the sequence diagram.

- 5 - 65,535 seconds adjustable

Switch-off time

After the delay time has elapsed, the "Bat. mode" signal output is activated. This signal output remains in the activated state for the entire set time. This means that the IPC receives the request to shut down. The IPC continues to be supplied with power by the charging and control unit for the entire set time.

- 0 - 65.535 seconds adjustable

Waiting time

After the switch-off time has elapsed, the output voltage is switched off if the input voltage is present again between the end of the delay time and the start of the waiting time. This gives the IPC the necessary 0 - 24 V edge for a restart after the PC idle time has elapsed.

If the input voltage is not restored after the switch-off time has elapsed, the charging and control unit, including the output, is switched off permanently. After the module is switched off, an automatic restart with connection of the DC 24 V at the output only takes place when the input voltage returns.

- 0 - 65.535 seconds adjustable

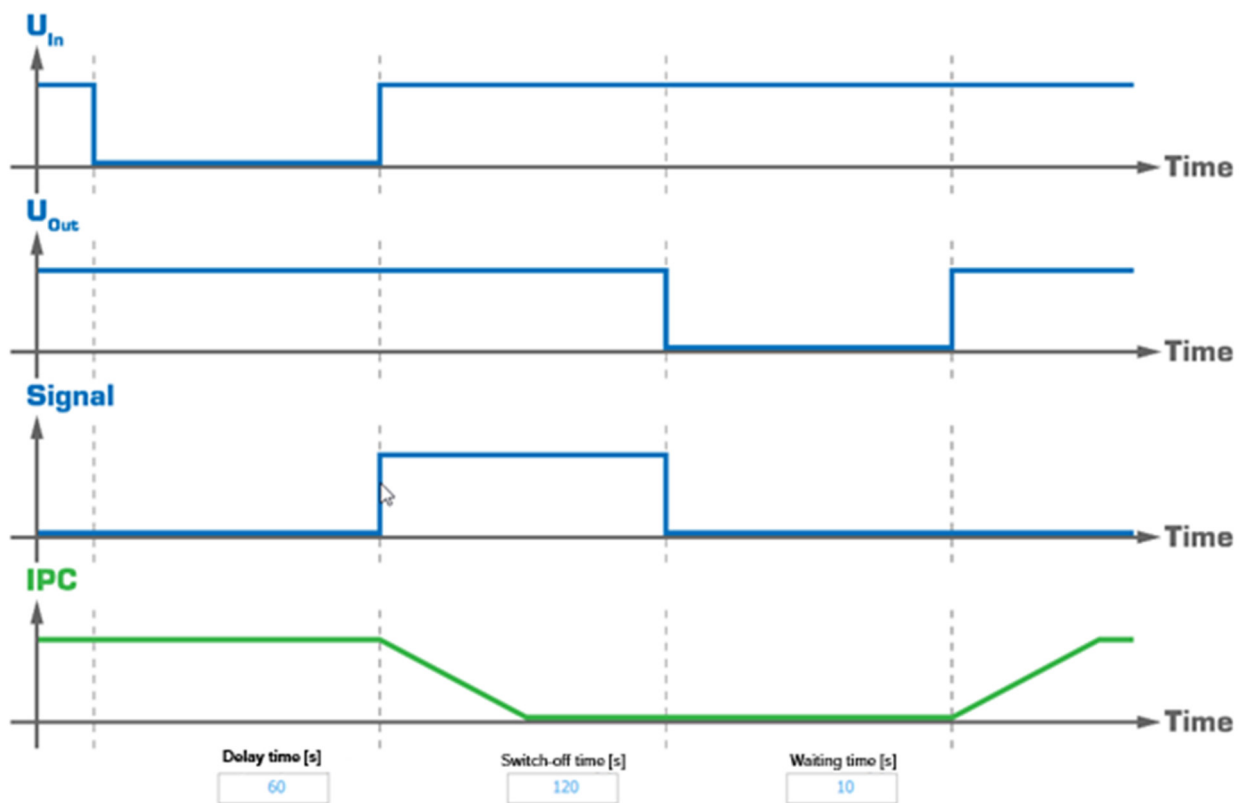

Figure 11: IPC setting

Remote switch-off in buffer mode

If the load connected to the output of the charging and control unit is not to be supplied from the battery module during buffer operation, e.g. in EMERGENCY OFF mode, buffer operation can be disabled. To do this, the connection between the two contacts R1/R2 of the "Remote" input must be interrupted.

If this connection is not available in normal operation, the module signals the fault "no buffer operation possible". The red LED lights up continuously. By default, this fault is linked to the "Alarm" signal output so that the contact is opened.

Deep discharge protection in buffer mode

In order to protect the installed battery modules against deep discharge, buffer operation is forcibly terminated in 24 V mode at a battery voltage $U_{bat} < 18\text{ V} - 19.2\text{ V}$ (deep discharge threshold adjustable). The module switches off the output.

The signaling by the flashing LEDs is maintained in the voltage range $U_{bat} < 19.2\text{ V}$ in 24 V operation after the output is switched off, before the module switches off completely when the voltage falls below $U_{bat} < 18\text{ V}$ in 24 V operation. After the output is switched off, the output is only switched on again when the input voltage returns.

From a battery voltage $U_{bat} < 20.4\text{ V}$ in 24 V operation, the module signals the warning "Battery is almost empty" by flashing the yellow LED at 4 Hz.

4.5 Buffer times of the battery modules

The following diagram shows the maximum possible buffer times of the battery modules. The buffer times symbolize typical average values and result for new battery modules after full charging.

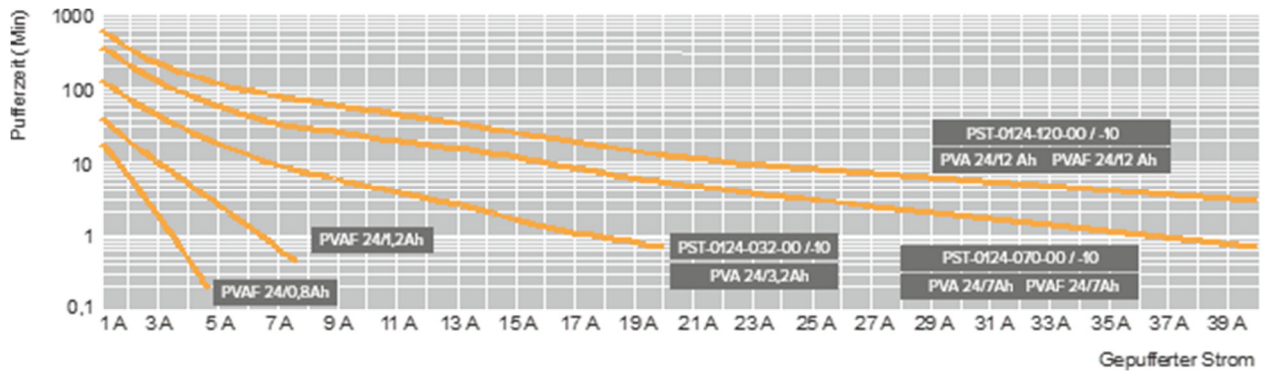

Figure 12: Buffer times of the battery modules

The buffer time can be extended by connecting up to three battery modules in parallel. Please note that only identical battery modules with the same state of charge may be connected.

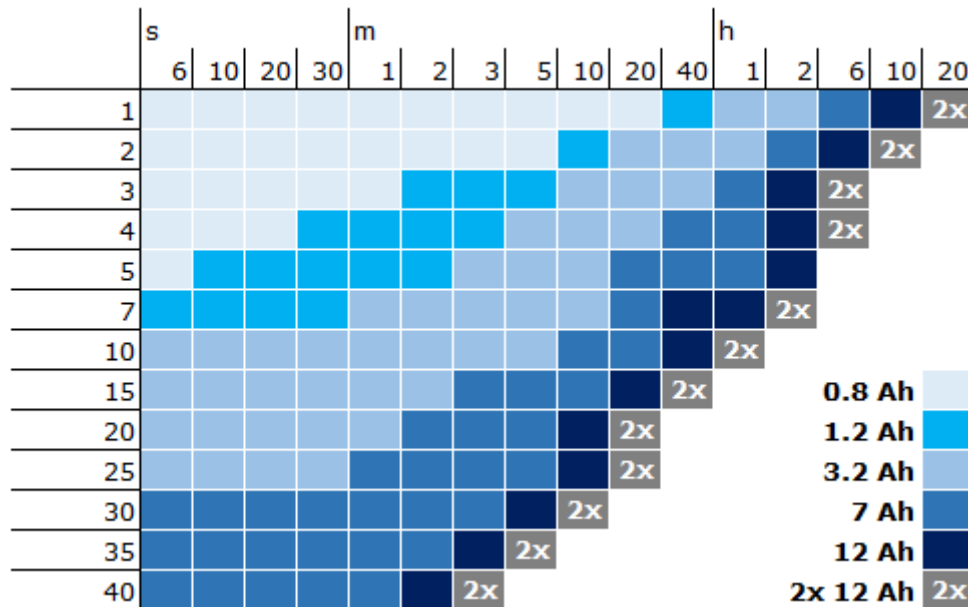

Figure 13: Buffer time as a function of the load current

4.6 Derating

The function of the charging and control units is not restricted by derating.

5. MAINTENANCE

5.1 Service life of the battery modules

The battery modules in the PVA, PVAF and PST series contain sealed, maintenance-free lead fleece accumulators that are designed for temperatures ranging from -10 °C to +40 °C. Depending on the ambient temperature, the service life of these battery modules is between 5 years at 20 °C and one year at 40 °C.

The remaining service life is calculated dynamically depending on the ambient temperature of the battery module, provided that both control cables are connected between the charging and control unit and the battery module. In addition, the battery modules are cyclically loaded in order to detect when a permissible voltage drop is exceeded. This allows conclusions to be drawn about damaged batteries even before the end of their service life.

5.2 Storage of the battery modules

The battery modules are delivered pre-charged to ensure immediate availability. The date of the last charge is indicated on the packaging. The latest commissioning should take place after 9 months at 20 °C - 30 °C or after 6 months at 30 °C - 40 °C after the last charge.



ATTENTION

The battery modules must not be stored upside down when switched off. See the PST battery module manual.



ATTENTION

When shipping or storing the UPS system, the corresponding device fuse must be removed to protect the battery modules, the corresponding device fuse must be removed.

6. USV FIRMWARE UPDATE

For the UPS-Control software, see the **UPS-Control software manual**