

# MANUAL

UNINTERRUPTED  
POWER SUPPLY

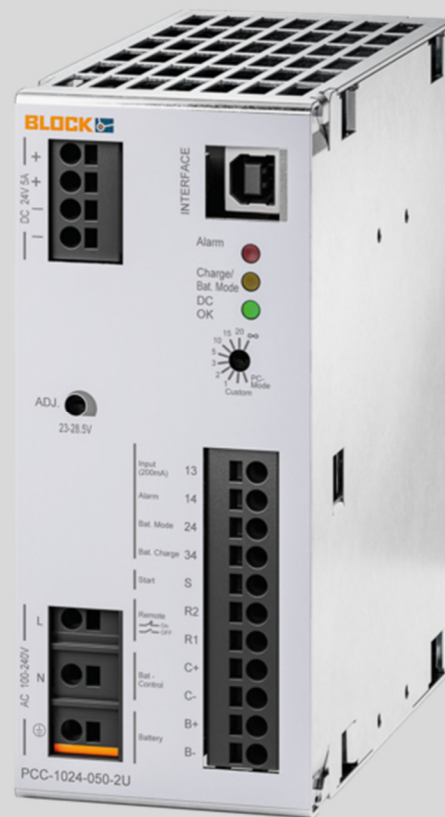

## POWER SUPPLY WITH INTEGRATED CHARGE AND CONTROL UNIT **PCC-1024**

# TABLE OF CONTENTS

|   |           |
|---|-----------|
| <b>1 ... ORDERING DATA.....</b>         | <b>3</b>  |
| <b>2 .. GENERAL INFORMATION.....</b>    | <b>4</b>  |
| 2.1 Safety.....                         | 4         |
| 2.2 Qualified personnel .....           | 4         |
| 2.3 Intended use .....                  | 4         |
| 2.4 Disclaimer.....                     | 4         |
| <b>3. .. PRODUCT.....</b>               | <b>6</b>  |
| 3.1 Block diagram .....                 | 7         |
| 3.2 Dimensioning.....                   | 8         |
| 3.3 Assembly.....                       | 9         |
| 3.4 Connections and signalling .....    | 11        |
| <b>4. .. COMMISSIONING .....</b>        | <b>12</b> |
| 4.1 Operating states/ signalling .....  | 12        |
| 4.2 Battery Testing .....               | 14        |
| 4.3 Battery.....                        | 15        |
| 4.4 Battery operation .....             | 17        |
| <b>5. .. Maintenance.....</b>           | <b>21</b> |
| 5.1 Battery module life .....           | 21        |
| 5.2 Storage of the battery modules..... | 21        |
| <b>6. .. UPS Firmware Update .....</b>  | <b>22</b> |
| 6.1 Preparation .....                   | 22        |
| 6.2 Performing a firmware update .....  | 23        |
| 6.3 Troubleshooting .....               | 24        |
| <b>7.... Specifications .....</b>       | <b>26</b> |
| 7.1 PCC-1024-050/100-20 .....           | 26        |
| 7.2 PCC-1024-050/100-2U .....           | 27        |

## 1. ORDERING DATA

The following table shows the order data of the Combi UPS and the battery modules.

Table 1: Order Numbers

| Combi UPS       |               |                       |                  |
|-----------------|---------------|-----------------------|------------------|
| Variant         | Input voltage | Output current        | Interface        |
| PCC-1024-050-20 | 230 Vac       | 5 A                   | NO               |
| PCC-1024-050-2U | 230 Vac       | 5 A                   | YES              |
| PCC-1024-100-20 | 230 Vac       | 10 A                  | NO               |
| PCC-1024-100-2U | 230 Vac       | 10 A                  | YES              |
| BATTERY MODULES |               |                       |                  |
| Variant         | Input voltage | Output current rating | Nominal Capacity |
| PVAF 24/0,8 Ah  | 24 Vdc        | max. 5 A              | 0,8 Ah           |
| PVAF 24/1,2 Ah  | 24 Vdc        | max. 7,5 A            | 1,2 Ah           |
| PVAF 24/7 Ah    | 24 Vdc        | max. 40 A             | 7 Ah             |
| PVAF 24/12 Ah   | 24 Vdc        | max. 40 A             | 12 Ah            |
| PVA 24/3,2 Ah   | 24 Vdc        | max. 20 A             | 3,2 Ah           |
| PVA 24/7 Ah     | 24 Vdc        | max. 40 A             | 7 Ah             |
| PVA 24/12 Ah    | 24 Vdc        | max. 40 A             | 12 Ah            |
| PST-0124-032-00 | 24 Vdc        | max. 20 A             | 3,2 Ah           |
| PST-0124-070-00 | 24 Vdc        | max. 40 A             | 7 Ah             |
| PST-0124-070-10 | 24 Vdc        | max. 40 A             | 7 Ah             |
| PST-0124-120-00 | 24 Vdc        | max. 40 A             | 12 Ah            |
| PST-0124-120-10 | 24 Vdc        | max. 40 A             | 12 Ah            |
| PST-0124-180-00 | 24 Vdc        | max. 40 A             | 18 Ah            |
| PST-0124-400-00 | 24 Vdc        | max. 40 A             | 40 Ah            |

### UPS-Control Software

Visualization and configuration software for the charging and control unit. Free download at [www.block.eu](http://www.block.eu). For the display and individual setting of the loading and control unit.

## 2. GENERAL INFORMATION

### 2.1 Safety

Please read these warnings and safety instructions carefully before using the device. The device may only be installed by competent and qualified personnel. In the event of malfunctions or damage, immediately switch off the supply voltage and send the device to BLOCK Transformatoren-Elektronik GmbH for inspection. The device does not include any service components. If an internal fuse is tripped, there is most likely an internal defect in the device. The data provided are for product description purposes only and are not to be regarded as warranted properties in the legal sense.

### 2.2 Qualified personnel

The product associated with this documentation may only be handled by qualified personnel in compliance with the documentation related to the respective task, in particular the safety and warning instructions contained therein. Qualified personnel can guarantee on the basis of their training and experience that the use of the described product meets all safety requirements as well as the applicable regulations, regulations, standards and laws.

### 2.3 Intended use

This device is designed to be installed in an enclosure and is suitable for use with general electronic devices, such as industrial controls, office equipment, communication equipment or measuring instruments. Do not use this device in control systems of aircraft, trains or nuclear facilities where malfunction could result in serious injury or danger to life.

### 2.4 Disclaimer

The content of this publication has been checked with the greatest care for compliance with the hardware and software described. Nevertheless, there may be discrepancies between the product and the documentation. Deviations can also occur due to the constant further development of the product. For this reason, we cannot guarantee complete compliance. If this documentation contains errors, we reserve the right to make necessary corrections without prior notice.



**ATTENTION**

Switch off the input voltage before installation, maintenance or modification work and protect it against unintentional reconnection.



**ATTENTION**

Do not make any modifications or repair attempts to the device. Do not open the device!



**ATTENTION**

Prevent the ingress of foreign objects, such as paper clips and metal parts.



**ATTENTION**

Do not operate the appliance in a humid environment or in an environment where condensation or condensation.



**ATTENTION**

Do not touch the housing during operation or shortly after shutting down.  
Hot surfaces can cause injuries.

### 3. PRODUCT

An uninterruptible power supply system maintains the DC 24V supply voltage even if the mains voltage to be supplied fails. Consumers continue to work reliably without interruption.

The Combi UPS combines power supply and charging and control unit in one housing, reducing the space required and wiring effort in your control cabinet.

The entire system consists of only two functional units in a combi UPS:

- AC/DC power supply and charging and control unit in one device
- DC 24V battery module for energy storage

All components for the construction of an uninterruptible power supply system are optimally matched to each other. They are quick to install and ready to use from the first time you turn them on.

Connected battery modules with "**Battery Control**" are automatically detected by the **combi UPS**. Dynamic adjustments such as the optimal charging current per battery module or a temperature-dependent charging voltage maximize the service life of the installed batteries in the long term.

The system can be integrated into the control system via several signal contacts and an integrated interface. Critical operating conditions are signaled at an early stage, even before the maintenance of the 24V system voltage is endangered.

The **combined UPS** enables the controlled shutdown of an industrial PC (IPC) after an individual buffer period. The device also ensures the important restart of the industrial PC when the supply voltage returns.



Figure 1: PCC-1024-050-2U

### 3.1 Block diagram

The battery module is connected via the "Battery +/-" connection terminals. For error-free operation, the control contacts R1/R2 for remote shutdown must be closed either via a bridge or an (EMERGENCY) STOP SWITCH.

Connected battery modules with **"Battery Control"** are automatically detected if both control lines "Bat. Control +/-" for communication between the modules with correct polarity.

Dynamic adjustments such as the optimal charging current per battery module or a temperature-dependent charging voltage are automatically adjusted depending on the battery module used and sustainably maximize the service life of the installed batteries.

**For an optimal supply of the accumulators, operation with connected control cables and battery modules with "Battery Control" is recommended. The polarity must be observed.**

If several battery modules are connected in parallel, the control cables must only be connected to one battery module. No adjustments are required on the charging and control unit for the parallel operation of battery modules.

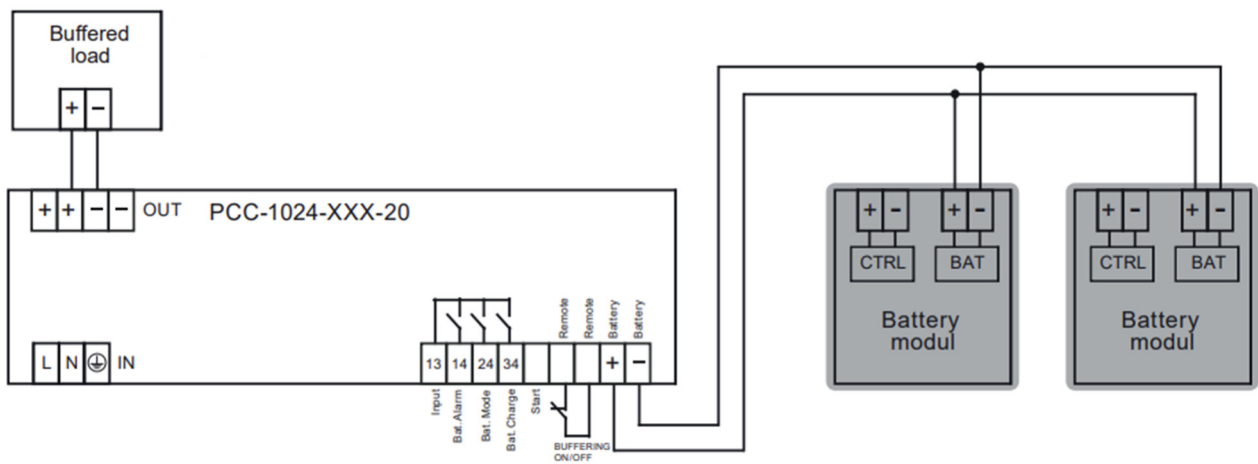

Figure 2: Wiring block diagram PCC-1024-xxx-20

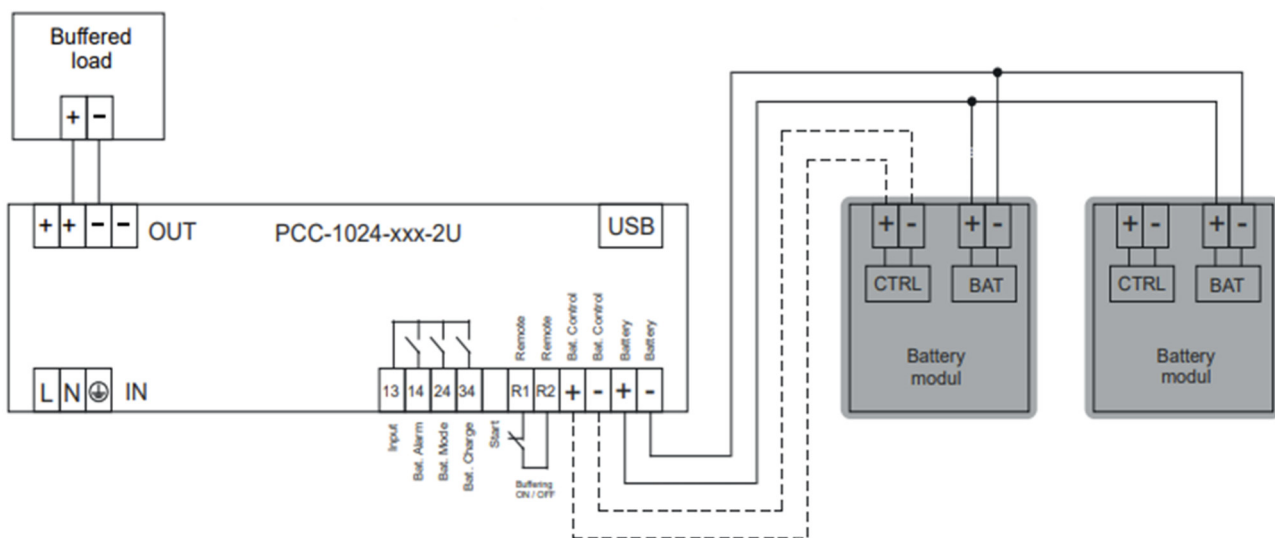

Figure 3: Wiring block diagram PCC-1024-xxx-2U

### 3.2 Dimensioning

The dimensions of the PCC-1024-050-xx UPS and PCC-1024-100-xx combinations are shown in Figures 3 and 4.

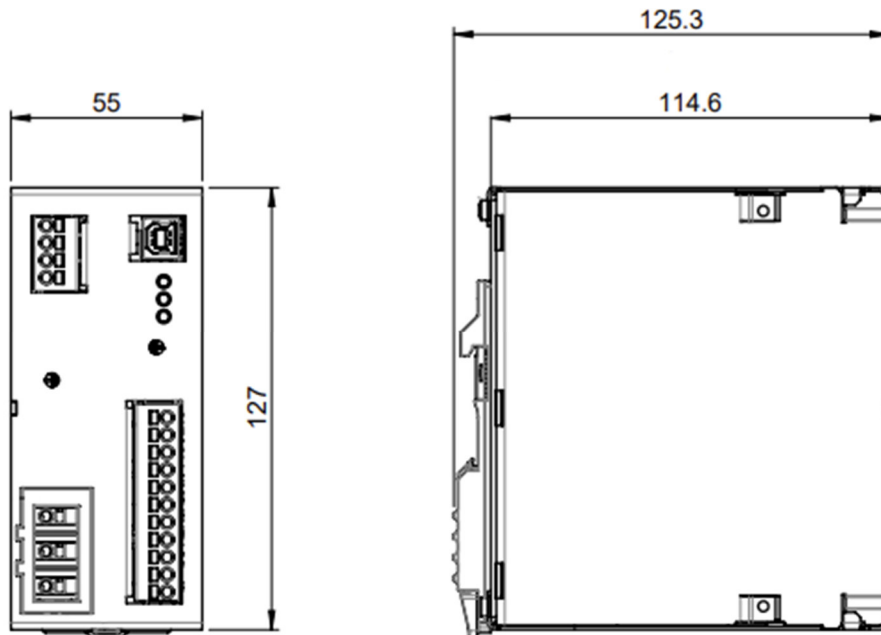

Figure 4: PCC-1024-050-2U/20

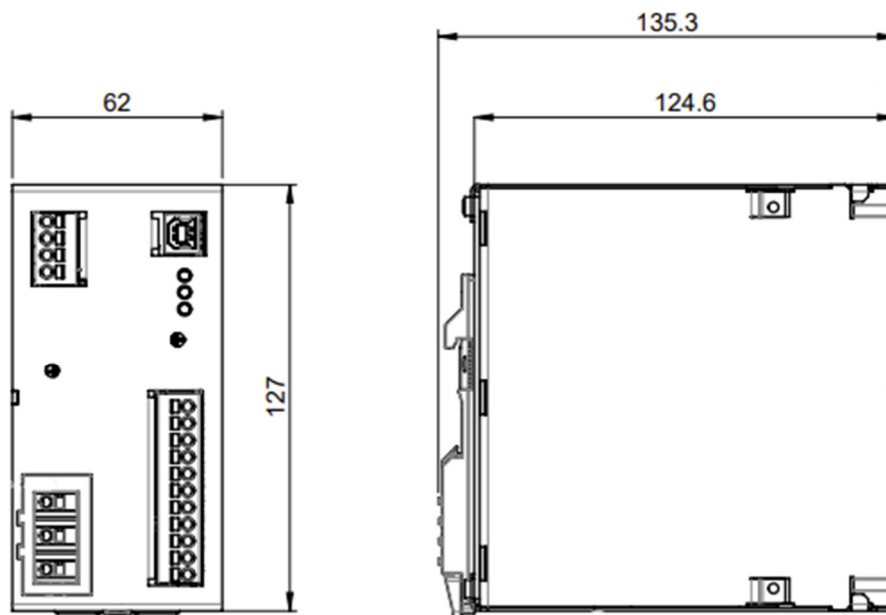

Figure 5: PCC-1024-100-2U/20

The dimensions of the associated battery modules can be found in the operating instructions for the battery modules.

### 3.3 Assembly

The combi UPS can be mounted on the DIN rail without tools.

To do this, the front of the device is first turned slightly upwards and placed on the DIN rail. It should be noted that the device is pushed down to the stop. When the device sits on the DIN rail, the underside is pressed against the mounting rail until it is locked in the DIN rail (followed by a "click" sound). To check, shake the device again lightly to ensure proper locking.

A standard tool, such as a flat-head screwdriver, is required for disassembly. By pressing down the fastener, the device can be detached from the DIN rail by lifting the underside of the device.

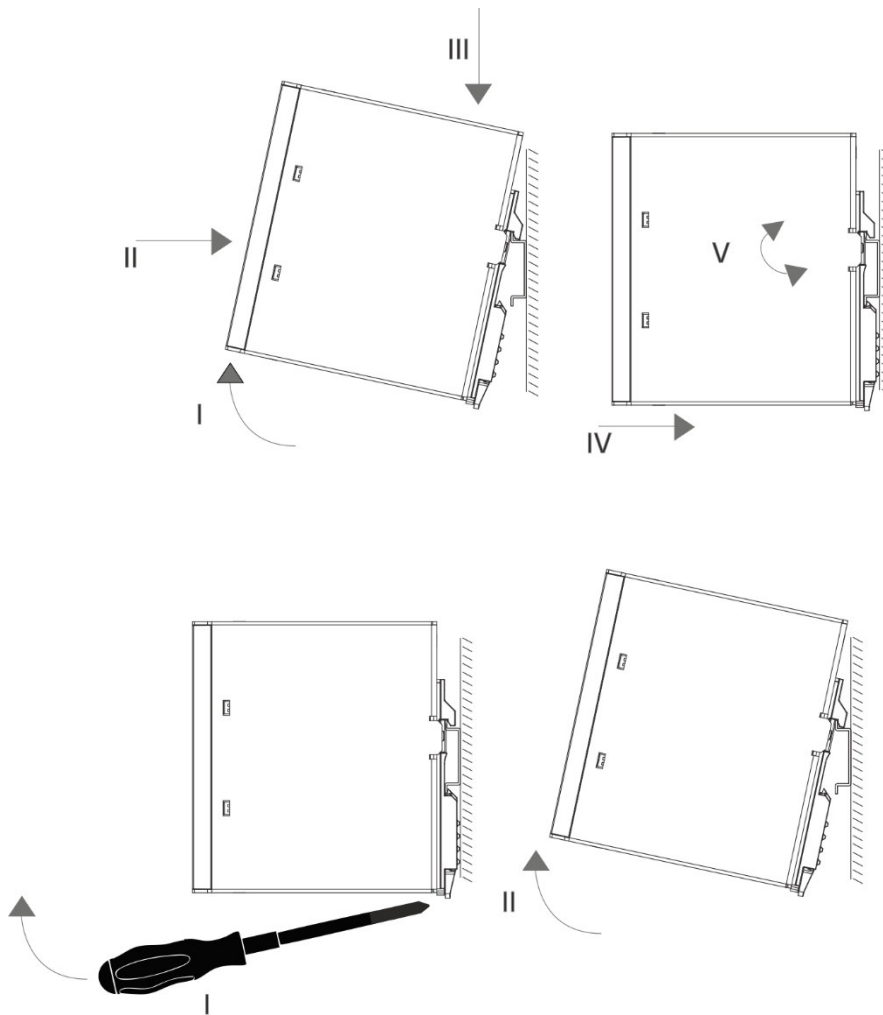

Figure 6: Assembly



#### ATTENTION

Mounting the battery modules overhead is not permitted.

To ensure cooling by natural convection, a distance of at least 40 mm from neighboring devices must be maintained at the bottom and top. Direct lateral mounting of other devices is permitted.

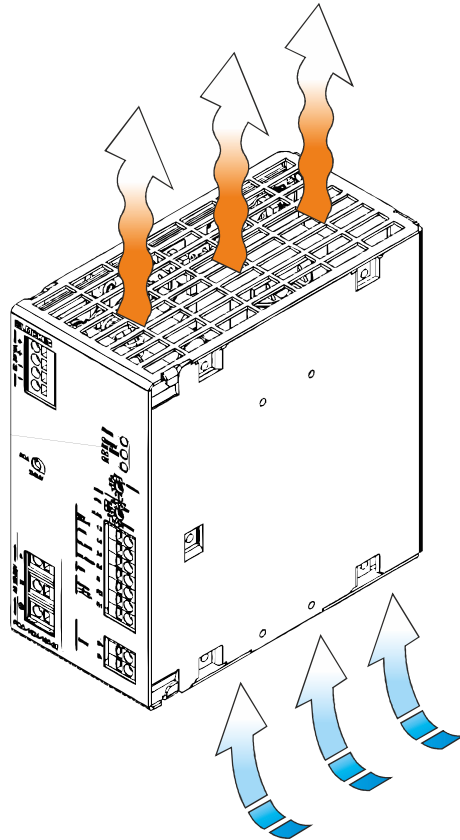

Figure 7: Convection Cooling



**ATTENTION**

Mount the device horizontally only. A different assembly is not permitted.

### 3.4 Connections and signalling

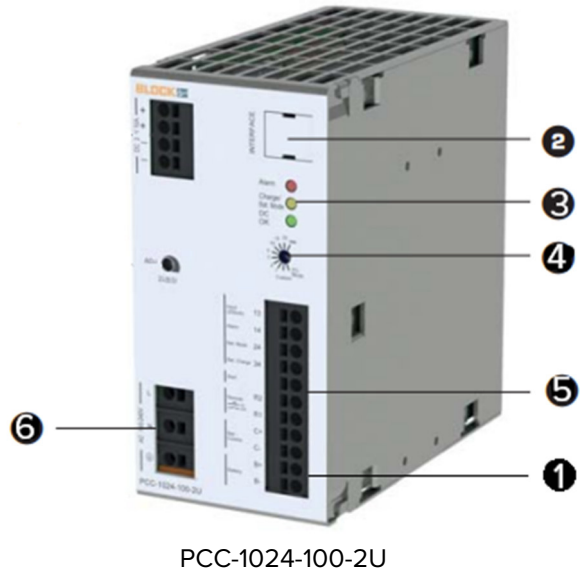
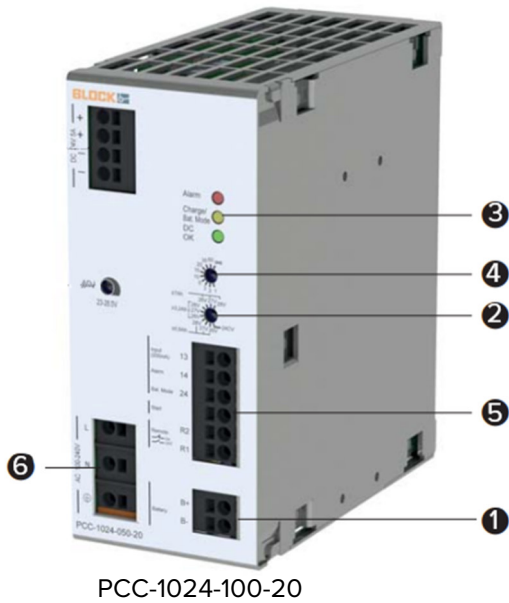

| Nr. | Function   | Note  |
|-----|--|---|
| 1   | Battery terminal   | 0,75 – 16 mm <sup>2</sup> (20...4 AWG)  |
| 2   | Rotary switch for setting the battery module<br>PC interface | Adjusting the battery modules<br>USB interface port<br>(USB Type B)   |
| 3   | Indicators   | LED red: Alarm<br>LED yellow: Bat. Charge /Bat. Mode<br>LED green: DC OK  |
| 4   | Rotary switch for buffer time setting                        | Buffering time in minutes (1-20)<br>IPC-Mode (PC-Mode)<br>Maximal time (∞)<br>Individually via settings of the configuration software   |
| 5   | Signal and signaling contacts                                | 13: Potential-free collective input<br>for signal outputs 14/24/34<br>14: Alarm (default = active low)<br>24: Battery Mode<br>(default = active high)<br>34: Battery Charge<br>(default = active high)<br>Start: Start-up in battery mode<br>R1/R2: Remote shutdown in the<br>Buffering<br>C+/C-: Control cable for<br>„Battery Control“<br>0,2-2,5 mm <sup>2</sup> (24...12 AWG) |
| 6   | Input voltage terminals                                      | 0,75-16 mm <sup>2</sup> (20...4 AWG)  |

## 4. COMMISSIONING

After connecting battery modules with "Battery Control", they are automatically detected, provided that the control cable "C+/C-" is connected for communication between the modules with the correct polarity. In order to use the functionality of "Battery Control", both control cables of the combi UPS must be connected to the "BAT CTRL" connectors of the battery modules with the correct polarity.

Dynamic adjustments such as the optimal charging current depending on the battery module used and a temperature-dependent charging voltage sustainably maximize the service life of the installed batteries.



### NOTE

For optimal supply of the battery modules, operation with connected Control cables and battery modules with "Battery Control" recommended. The polarity must be observed. Before the module is powered, the battery modules should be fully connected to avoid false signaling.

### 4.1 Operating states/ signalling

The combi UPS module can signal current operating states, warnings or faults. Three indicator lights (LED) and three potential-free contacts are available for function monitoring.

Table 2: Configured Signal Outputs

| Condition  | Signal output     | Function          |
|--|-------------------|-------------------|
| No battery operation possible or battery replacement recommended | Alarm 13/14       | Active low (0V)   |
| UPS works on battery power                                       | Bat. Mode 13/24   | Active high (24V) |
| Charging the battery module                                      | Bat. Charge 13/34 | Active high (24V) |

The Kombi UPS is able to detect several events that can be individually linked to the three signal outputs via the UPS-Control configuration and management software. The logic (inverted / non-inverted or active high / active low ) can also be changed if necessary

Table 3: Detectable Events

| Nr. | Description   |
|-----|---|
| 1   | Battery   |
| 2   | No battery operation possible:<br>Presence test negative or connection for remote shutdown (remote input) not available |
| 3   | Battery replacement recommended   |
| 4   | Charging the battery  |
| 5   | Battery is almost empty   |
| 6   | Deep discharge protection active  |
| 7   | Output voltage not OK   |
| 8   | Output is overloaded  |

Table 4: Signaling via LED status indicators

| Operating status   | LED green | LED yellow       | LED red        |
|--|-----------|------------------|----------------|
|  | DC OK     | Charge/Bat. Mode | Alarm          |
| UPS works in normal operation<br>Output voltage > 20.4 V<br>Battery is charged and OK  | On        | Off              | Off            |
| UPS works in normal operation<br>Charging the battery<br>(Charge < 85% of rated capacity)  | On        | On               | Off            |
| UPS works in normal operation,<br>no battery operation possible<br>(Presence test negative or remote shutdown<br>R1/R2 active)                                   | On        | Off              | On             |
| UPS works in normal operation<br>Battery replacement recommended   | On        | Off              | Flashes (2 Hz) |
| UPS works on battery power<br>Battery voltage > 20.4V  | On        | Flashes (2 Hz)   | Off            |
| UPS works on battery power<br>Battery voltage >= 20.4V   | On        | Flashes (8 Hz)   | Off            |
| UPS over-discharge protection has stopped bat-<br>tery operation<br>(Battery voltage <= 19.2V)<br>Only the signalling is used for max.<br>Continued for 10 hours | Off       | Off              | Flashes (2 Hz) |
| UPS works in battery operation,<br>DC output was shut down due to overcurrent  | Off       | X                | Flashes (2 Hz) |

## 4.2 Battery Testing

*The combi UPS* performs different tests of the accumulators depending on the operating condition. If irregularities are detected, appropriate warnings or disruptions are generated.

### *Status Charging*

In normal operation, the battery module is charged. During charging, the state of charge is checked every 60 seconds.

If the batteries are less than 85% charged, the "battery is charging" status is signaled. The yellow LED lights up and the "Bat Charge" signal output is activated.

### *Presence test*

The presence test is used to detect a correctly connected and functional battery module and is carried out in normal operation. During the presence test, the battery modules are subjected to a slight load for a short time to ensure that the battery module is connected correctly, that the batteries are functional and that the fuse is intact.

The face-to-face test is carried out every 60 seconds in normal operation. In the event of a negative result, the test is repeated cyclically at 30-second intervals.

If the quality test yields a negative result, the warning "Battery replacement recommended" is generated. The red LED will flash and the "Alarm" signal output will be activated.



#### **NOTE**

It is recommended that the battery module be replaced as soon as possible after the warning occurs in order to maintain a safe buffer operation.

At the end of the service life, either both batteries must be replaced in pairs or the entire battery module. The battery module must be used to confirm the replacement of the batteries. To do this, press the reset button for 5 seconds with a sharp object (e.g. paper clip). To check, all three indicator lights flash for 5 seconds after successful acknowledgment. The stored operating hours are reset in order to be able to correctly calculate the remaining service life of the new batteries.

### 4.3 Battery

Intelligent battery management enables dynamic adjustments such as setting the optimal charging current or a temperature-dependent charging voltage for all detected battery modules with "Battery Control".

#### Temperature-dependent charging voltage

By measuring the real temperature directly in the battery module with "Battery Control", the charge is temperature-compensated. The service life of the installed batteries is thus sustainably extended. Further settings of charging parameters are not necessary due to the automatic detection.

The charge control is based on an IUoU charging characteristic. This is a 3-stage charging procedure, which is as follows.

Abbildung 7: Ladecharakteristik

| Level | Name                | Description   |
|-------|---------------------|---|
| 1     | Main charge         | Konstantstromladephase<br>initialer Ladestrom               |
| 2     | Compensatory charge | Konstantspannungsladephase<br>Ausgleichsladeschlussspannung |
| 3     | Trickle charging    | Konstantspannungsladephase<br>Erhaltungsladeschlussspannung |

In the event of interruptions in the communication cable between the combi UPS and the battery module, the temperature recorded in the combi UPS shall be used as a substitute to ensure temperature compensation.

The same applies when using battery modules in a different way from the **"Battery Control" functionality**

In these cases, charging is not carried out according to the 3-stage IUoU charging method, but with the temperature-compensated trickle charging end-of-charge voltage. The adjustment of general charging parameters must be checked and ensured individually depending on the battery module used.



#### NOTE

The temperature compensation of battery modules without "Battery Control" is treated as if there were a communication interruption.

If battery modules are used without communication, the adjustment of general charging parameters must be checked and ensured individually depending on the battery module used.

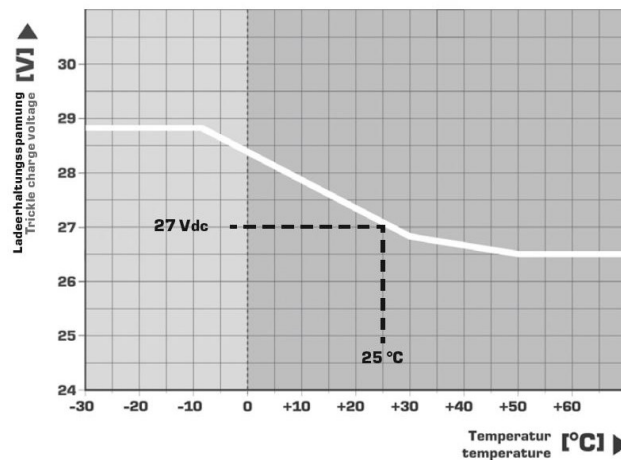

Figure 8: Compensation charging characteristic curve

Automatic temperature compensation can be deactivated at any time via the configuration software. A fixed value for the final float voltage can be stored individually.



**NOTE**

The configuration software can be used at any time to set an individual charging current as set point, regardless of the battery module used.

- Unlimited until deep discharge protection stops buffering
- Individual time via configuration software
- PC Mode, see chapter "Buffering in IPC Mode"

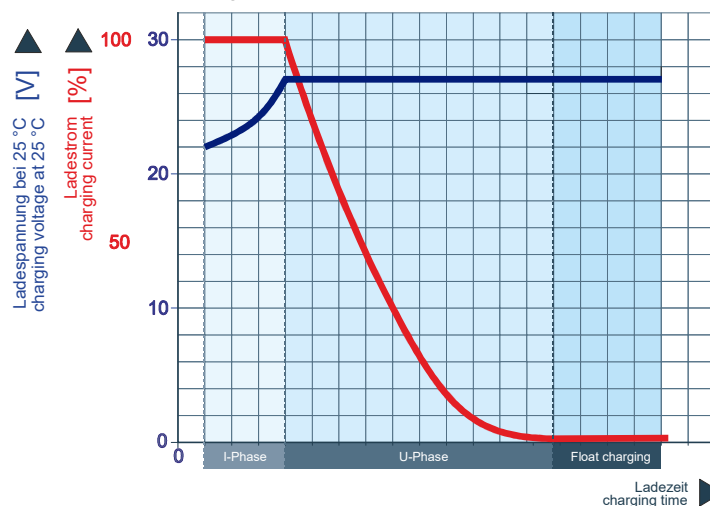

**Setting the end-of-charge voltage:**

The end-of-charge voltage of the PCC-1024-xxx-2U can be set via the UPS Control software by connecting the combi UPS to the PC via the existing interface and setting the desired parameters.

The end-of-charge voltage of the PCC-1024-xxx-20, on the other hand, can only be adjusted via a second potentiometer on the front of the device. Using the potentiometer, you can manually set the end-of-charge voltage based on your existing battery, as well as on the existing ambient temperature.

## 4.4 Battery operation

In the event of a failure of the mains voltage, it switches to battery operation without interruption. The energy required to maintain the DC 24V supply voltage is taken from the battery module. The level of the output voltage is directly dependent on the state of charge and the capacity of the batteries.

The combo UPS module supports both maintaining the supply voltage for a configurable time and controlled shutdown and restarting of an IPC.

For the software shutdown of an IPC, the installation of the free Windows software "USV\_Control" is required. If the combi UPS module is connected to the IPC, the cyclically transmitted data from the module triggers the shutdown after an adjustable time.

The buffer operation is signaled by the slow flashing of the yellow LED (approx. 2Hz). This event is ex-factory with signal output "Bat. fashion".

### ***Switching threshold for buffer operation***

If the input voltage drops below the switching threshold, the energy from the battery module is switched to the output of the UPS without interruption. The **combined UPS module** is then in buffer mode. The activation threshold is preconfigured to 22V ex works. The additional threshold can be changed via the free configuration software.

20.0 – 25.5V adjustable

### ***Buffer operation with adjustable buffer time***

The module is preconfigured for maximum (unlimited) buffer time ex works. In this configuration, all the energy of the battery module is used to maintain the DC 24 V supply voltage. The buffer time can be set via the selector switch.

0,5 ... 20 minutes

Unlimited until deep discharge protection stops battery operation

Individual time via configuration software

PC mode, see chapter "Buffer operation in IPC mode"

### ***Buffer operation in IPC mode***

In IPC mode, the UPS module works according to a chronological sequence that serves the controlled shutdown and reliable restart of an IPC. Changeable times can only be adjusted via the configuration software. The signal for shutting down the IPC is transmitted via the potential-free signal contact selected in UPS Control.



#### **NOTE**

To activate IPC mode, the rotary switch on the charging and control unit must be set to PC mode. Only then does the IPC configuration appear in the UPS Control software.

### ***Delay***

If the mains voltage returns in buffer mode during the set delay time, the output of the combined UPS is not switched off.

The signal output "Bat. Mode" (can be configured via the configuration software) remains in the inactive state, so that no signal is generated for a shutdown of the IPC.

If the input network does not return until after the set delay time has elapsed, the output voltage and signal output are switched according to the flow diagram.

5-65,535 seconds adjustable

### ***Disconnecting time***

After the delay time has elapsed, the signal output "Bat. Mode" is activated. This signal output remains in the activated state for the entire set time. Thus, the IPC receives the request to shut down. During the entire set time, the IPC will continue to be powered by the combined UPS.

0-65,535 seconds adjustable

### ***Latency***

After the shutdown time has elapsed, the output voltage is switched off if the input voltage is available again between the end of the delay time and the beginning of the waiting time. This gives the IPC the necessary 0 – 24 V edge for a restart after the PC idle time has expired.

If the input voltage is not yet available again after the switch-off time has expired, the combined UPS including the output is permanently switched off. After the module has been switched off, an automatic restart takes place only by the return of the input voltage with the DC 24 V switching on at the output.

0-65,535 seconds adjustable

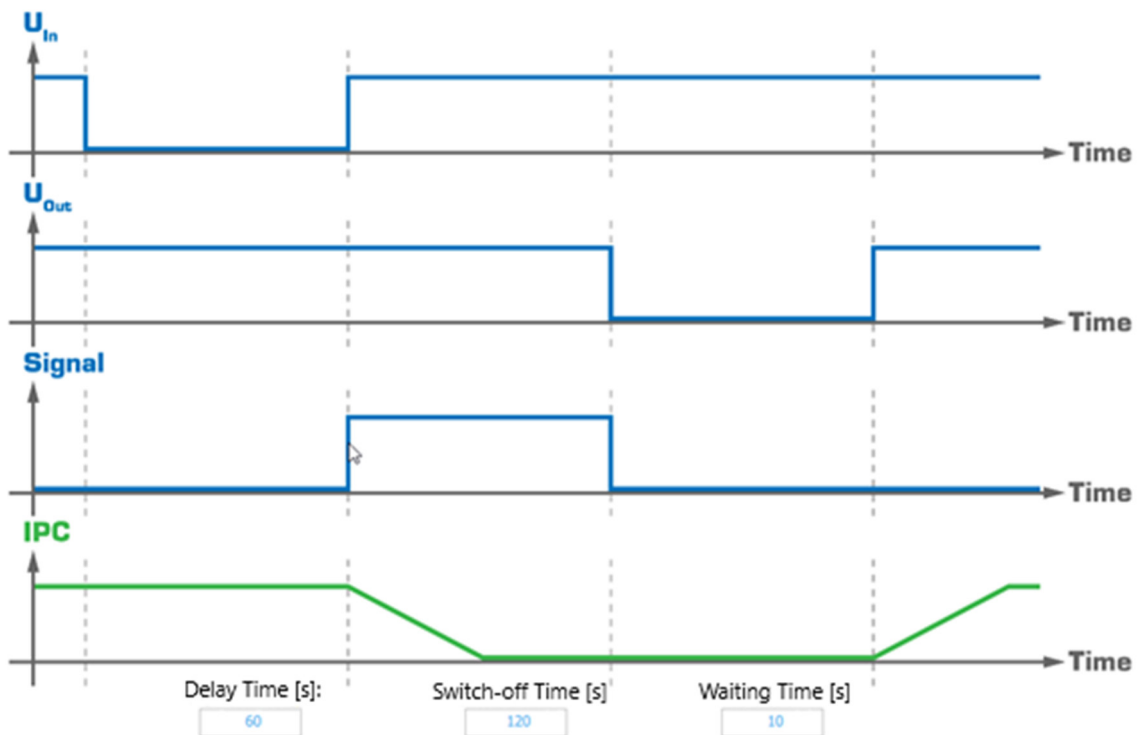

Figure 9: IPC Setting

### Remote shutdown in buffer mode

If the connected load at the output of the combi UPS module is not to be supplied from the battery module during battery operation, e.g. in EMERGENCY STOP mode, battery operation can be disabled. For this purpose, the connection between the two contacts R1/R2 of the "remote" input must be interrupted.

If this connection is not available during normal operation, the module signals the fault "no buffer operation possible". The red LED lights up continuously. This interference is linked to the "Alarm" signal output ex works, so that the contact is opened.

### Deep discharge protection in buffer mode

In order to protect the installed battery modules against deep discharge, the buffer operation is forcibly terminated at a battery voltage  $U_{bat} < 18\text{ V} - 19.2\text{ V} / 9\text{ V} - 9.6\text{ V}$  (deep discharge threshold adjustable) in 24 V / 12 V operation. The module switches off the output.

The signaling by the flashing LEDs is maintained in the voltage range  $U_{bat} < 19.2\text{ V} / 9.6\text{ V}$  in 24 V / 12 V after switching off the output before the module switches off completely after the voltage  $U_{bat} < 18\text{ V} / 9\text{ V}$  in 24 V / 12 V is dropped. After the output has been switched off, the output is only reconnected when the input voltage returns.

From a battery voltage  $< 20.4\text{ V} / 10.2\text{ V}$  in 24 V / 12 V operation, the module signals the warning "Battery is almost empty" by flashing the yellow LED at 4 Hz.

**Start from the battery**

It is possible to start the system directly in buffer mode without an existing input voltage. To do this, the "Start" contact on the front of the device must be briefly pulled to a negative potential using a push-button. There must not be a permanent bridge, otherwise the system will no longer switch off in the event of undervoltage. (See figure 9)

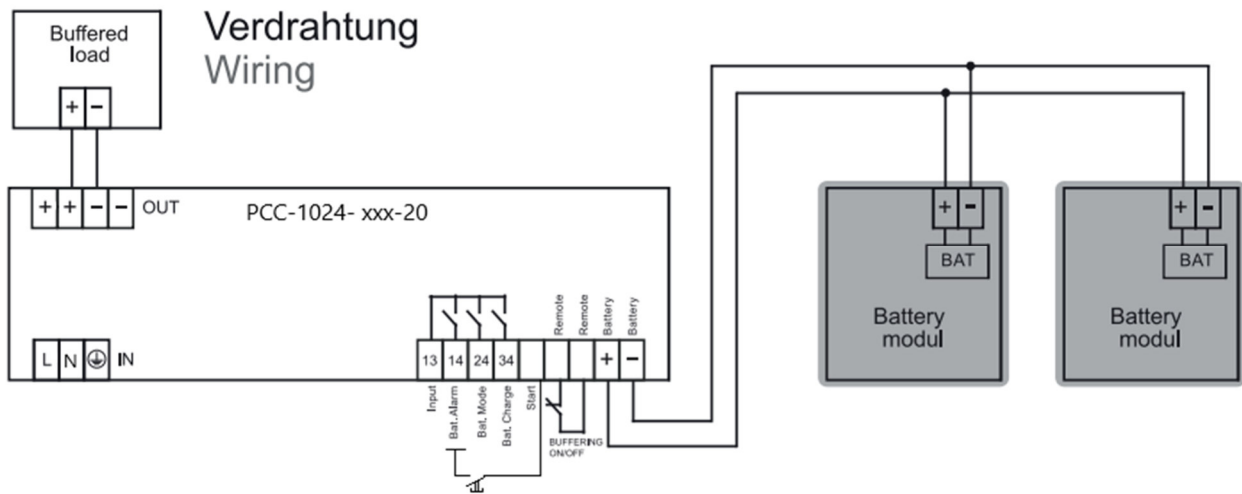

Figure 9: Wiring

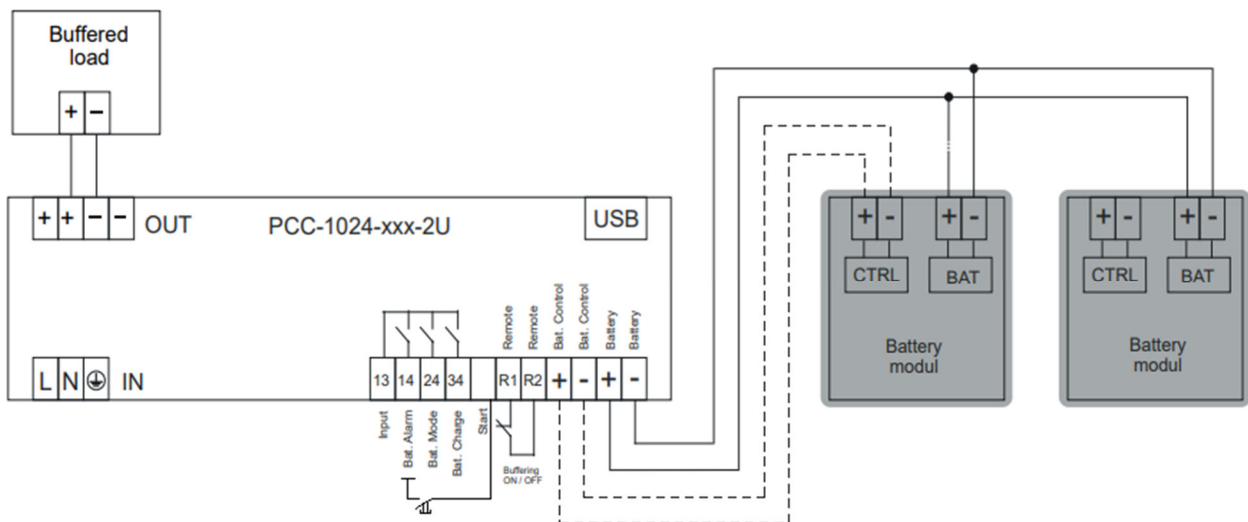

Figure 10: Wiring

## 5. Maintenance

### 5.1 Battery module life

The battery modules are equipped with sealed, maintenance-free lead-fleece batteries that are designed for -10 °C to +50 °C. Depending on the ambient temperature, the battery life ranges from 5 years at 20 °C to 2 years at 40 °C.

The remaining service life is dynamically calculated depending on the ambient temperature of the battery module, provided that both control lines are connected between the charging and control unit and the battery module. In addition, the battery modules are cyclically loaded to detect the exceeding of a permissible voltage drop. This allows conclusions to be drawn about accumulators that have already been damaged even before the end of their service life.

### 5.2 Storage of the battery modules

The battery modules are supplied with pre-charged accumulators to ensure immediate availability. The date of the last top-up is printed on the packaging. The latest start-up should take place after nine months at 20°C to 30°C or after six months at 30°C to 40°C after the last charge.



#### ATTENTION

The battery modules must not be stored overhead when switched off.

When shipping or storing the UPS system, the associated device fuse must be removed to protect the battery modules from discharge.



#### ATTENTION

Please disconnect the battery modules before updating the firmware. After updating, you can reconnect the battery modules and reset the battery voltage setpoint

## 6. UPS Firmware Update

### 6.1 Preparation

Install the current version of the UPS Control Software. Operate the UPS in nominal mode and navigate to the status page within the UPS Control Software:

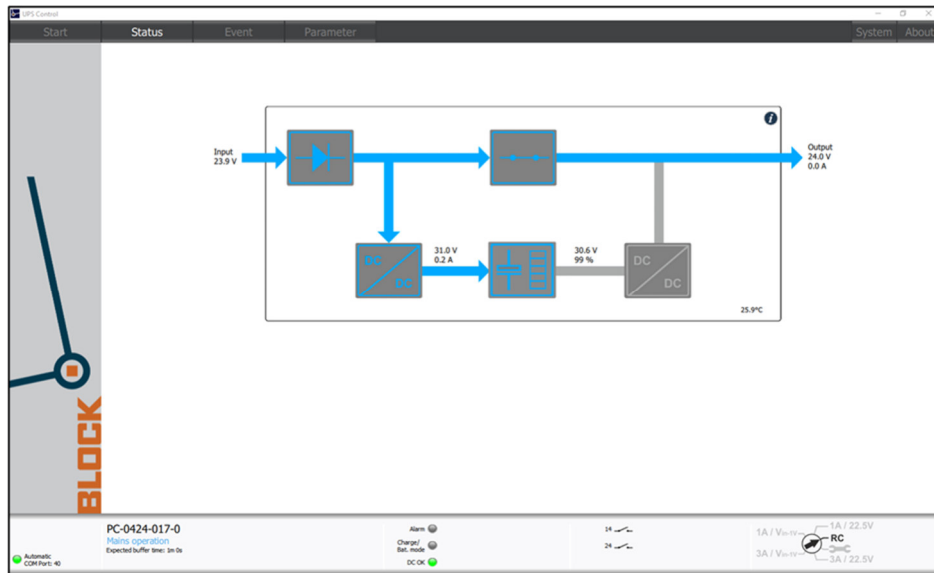

Now click on the small info symbol in the top right-hand corner to display the device information:

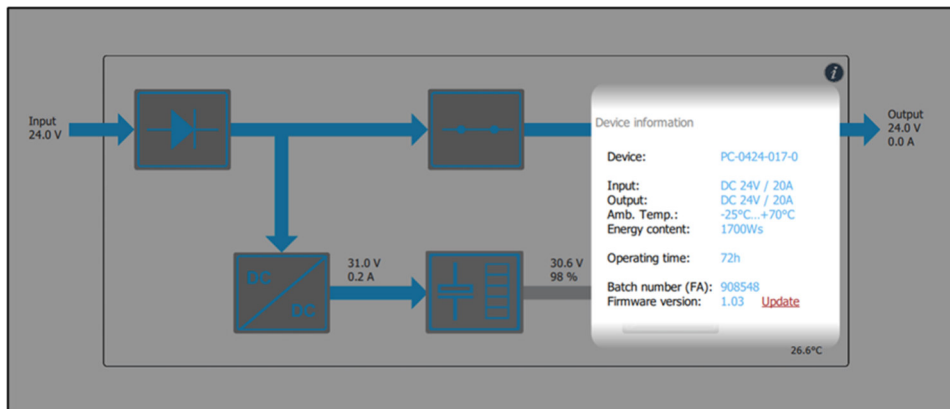

#### **Attention:**

Please disconnect the battery modules before updating the firmware. After the update, you can reconnect the battery modules and reset the target value of the battery voltage

## 6.2 Performing a firmware update

The last line of the info box shows the current firmware version. Next to it is a red link with the name "Update". Now click on this link. A dialog opens to select the "Firmware.bin" file from the computer's file system:

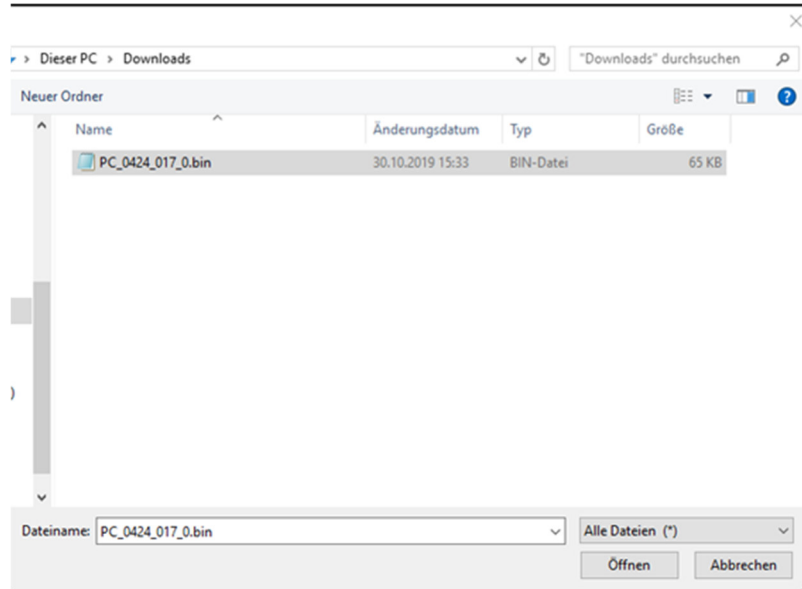

Now click on "Open". The update process begins and "Updating Firmware" appears in red in the bottom bar of the UPS Control software while the process is in progress. After completion, the UPS performs a reset and the UPS Control switches to the start page:



The firmware update has now been successfully completed.

## 6.3 Troubleshooting

If the firmware update fails and the device no longer works, it is still possible to update it again. To do this, navigate to the system page in UPS Control:

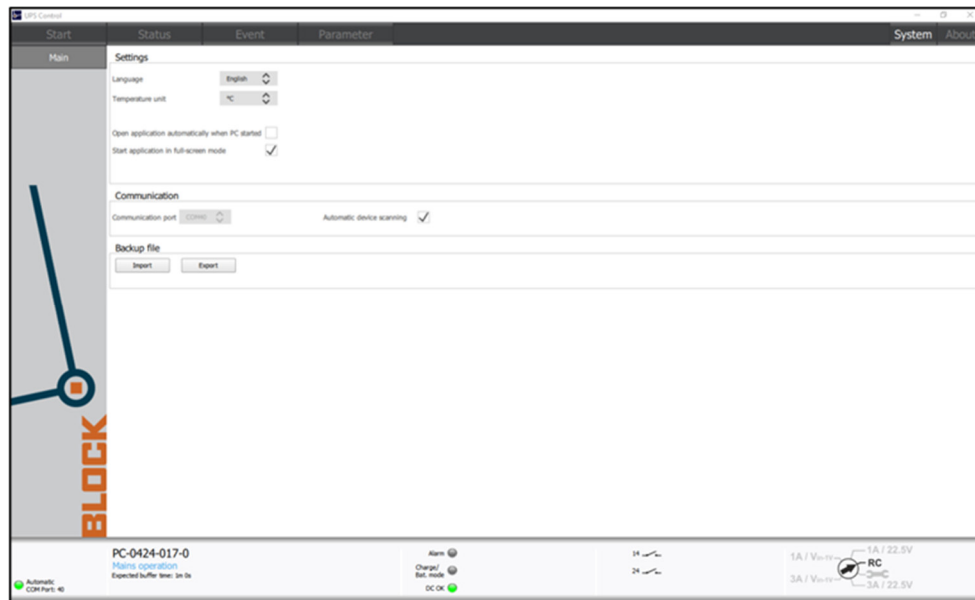

In the Communication area, uncheck the "Automatically detect device" box and, if not already checked, click the "Disconnect" button. Now switch to the start page and select the corresponding device directly (e.g.: PC-0424-017-0):



Now switch to the status page and click on the info box of the device:

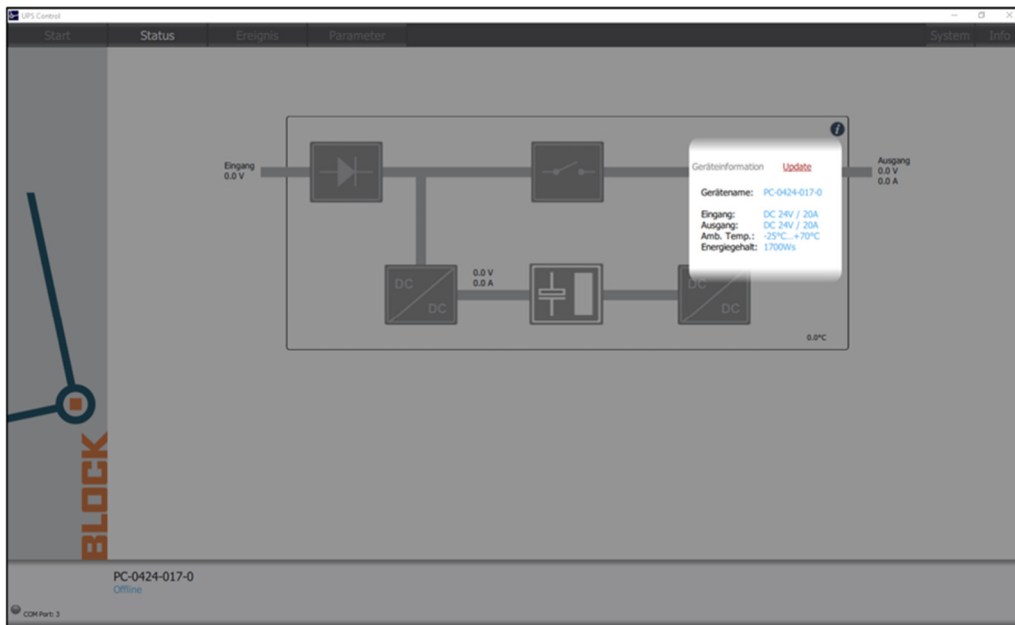

Ensure that the UPS is supplied with power. Then click on the "Update" link at the top of the info box, which opens the selection dialog for the "Firmware.bin" again. The writing of the firmware begins. Once the process is complete, automatic detection must be reactivated on the system page.

## 7. Specifications

### 7.1 PCC-1024-050/100-20

deutsch

english

#### Technische Daten

#### Technical data

|   |  | PCC-1024-050-20  | PCC-1024-100-20                     |
|---|--|--|-------------------------------------|
| <b>Eingangsdaten</b>  |  | <b>Input data</b>  |                                     |
| Eingangsnennspannung  | Nominal input voltage  | 100 - 240 Vac (100 - 240 Vdc)*   |                                     |
| Eingangsspannungsbereich  | Input voltage range  | 90 - 264 Vac (90 - 264 Vdc)*   |                                     |
| Nennfrequenzbereich   | Frequency range  | 47 Hz - 63 Hz / 0 Hz   |                                     |
| Eingangsstrom (bei Nennlast und Batterie ist geladen / Max.)  | Input current (at nominal load and battery is charged / max.)  | 2,00 A (100 Vac) / 0,95 A (230 Vac)  | 2,80 A (100 Vac) / 1,30 A (230 Vac) |
| Eingangsstrom (bei Nennlast und Batterie wird geladen / Max.)   | Input current (at nominal load and battery is being charged / max.)  | 2,60 A (100 Vac) / 1,20 A (230 Vac)  | 2,90 A (100 Vac) / 1,40 A (230 Vac) |
| Einschaltstrombegrenzung  | Inrush current limitation  | < 30 A, NTC  |                                     |
| Eingangssicherung, intern (Geräteschutz)  | Input fuse, internal (device protection)   | 6,3 A  |                                     |
| Vorgeschriebene Vorrichtung, Leitungsschutzschalter (Charakteristik)  | Required back-up fuse, circuit breaker (characteristic)  | 6 A, 10 A, 16 A (B,C)  |                                     |
| Transientenüberspannungsschutz  | Transient surge voltage protection   | Varistor   |                                     |
| Anschlüsse Eingang  | Terminals input  | Push-In, max. 2,5 mm <sup>2</sup>  |                                     |
| <b>Ausgangsdaten allgemein</b>  |  | <b>Output data</b>   |                                     |
| Ausgangsnennstrom   | Nominal output current   | 5 A  | 10 A                                |
| Ausgangsstrom Boost (5s)*   | Boost output current (5s)*   | 7,5 A  | 15 A                                |
| Ausgangsstrom Boost (kontinuierlich bis 45 °C / 100-264 Vac / 110-372 Vdc)                                  | Output current boost (continuous up to 45 °C / 100-264 Vac / 110-372 Vdc)  | 5,5 A  | 11 A                                |
| Auslösen von Leitungsschutzschaltern  | Tripping of standard circuit breaker   | max. B4  |                                     |
| Parallelschaltbarkeit zur Erhöhung der Systemverfügbarkeit  | Parallel connection to gain a higher system reliability  | , only with additional redundancy module for decoupling, max. 5 A output current |                                     |
| Restwelligkeit  | Ripple/noise   | typ. 50 mVss   |                                     |
| Rückspießfestigkeit   | Resistance to reverse feed   | max. 35 Vdc  |                                     |
| Überspannungsschutz des Ausgangs (OVP)  | Over-voltage protection  | typ. 38 Vdc  |                                     |
| Anschlüsse Ausgang  | Terminals output   | Push-In, max. 2,5 mm <sup>2</sup> (see Fig. 5)                                   |                                     |
| <b>Ausgangsdaten Netzbetrieb</b>  |  | <b>Output data in mains operation</b>  |                                     |
| Ausgangsnennspannung  | Nominal output voltage   | 24 Vdc ± 1%  |                                     |
| Ausgangsspannungsbereich  | Output voltage range   | 23 - 28,5 Vdc  |                                     |
| Ausgangsstrombegrenzung   | Output current limitation  | typ. 6,5 A   | typ. 13 A                           |
| Verlustleistung (Nennlast und Batterie geladen)   | Power losses (nominal load, battery charged)   | 21W / 15W  | 24,7W / 17W                         |
| Wirkungsgrad (Nennlast und Batterie geladen)  | Efficiency (nominal load, battery charged)   | typ. 89 %  | typ. 93 %                           |
| max. Verlustleistung (Batterie wird geladen)  | Maximum power losses (battery is charging)   | 30 W (90 Vac)  |                                     |
| <b>Ausgangsdaten Batteriebetrieb</b>  |  | <b>Output data in battery operation</b>  |                                     |
| Ausgangsnennspannung (abhängig von der Batteriespannung)  | Nominal output voltage (depends on the battery voltage)  | 24 Vdc   |                                     |
| Ausgangsspannungsbereich  | Output voltage range   | UBAT - 0,5 V (27,5 - 19 Vdc)   |                                     |
| Ausgangsstrombegrenzung   | Output current limitation electronic   | typ. 5,5 A   | typ. 11 A                           |
| max. Verlustleistung (Leerlauf/ Nennlast)   | Max. power losses (stand-by/nominal load)  | 3,2 W  | 5,2 W                               |
| Fernabschaltung   | Remote shut-down   |  |                                     |
| Aufschalten kapazitiver Lasten  | Connection of capacitive loads   | max. 10.000 µF   |                                     |
| einstellbare Pufferzeit   | Adjustable buffer time   | 1, 2, 3, 5, 10, 15, 20, 30, 60 Min.  |                                     |
| <b>Batteriemangement</b>  |  | <b>Battery management</b>  |                                     |
| Verpolschutz  | Reverse connection protection (fuse of battery module will be tripped)   |  |                                     |
| Ladecharakteristik  | Charging characteristic  | IU   |                                     |
| Ladestrom   | Charging current   | 0,2 ... 2,0 A  | 0,8 ... 3,0 A                       |
| Ladeschlussspannung (temperaturkompensiert)   | End-of-charge voltage (temperature compensated)  | 26 ... 28 V  |                                     |
| Zyklus für Batteriepräsenzprüfung   | Battery presence check/time  | 60 Sekunden  | 60 seconds                          |
| Tiefentladeschutz   | Protection against total discharge   | 19 V   |                                     |
| Schwelle Warnmeldung "Batteriespannung sehr gering"   | "Battery voltage very low" alarm signaling threshold   | 20,4 V   |                                     |
| empfohlene Batteriemodule   | Recommended battery modules  | 0,8 ... 7 Ah   | 1,2 ... 12 Ah                       |
| Parallelschaltung von Batteriemodulen / Max. 3 zur Verlängerung der Pufferzeit                              | Parallel connection of batteries / Max. 3 to increase the buffer time  |  |                                     |
| Leckstrom   | Leakage current  | < 0,1 mA   |                                     |
| <b>Signalisierung</b>   |  | <b>Signaling</b>   |                                     |
| Statusanzeige LED grün/gelb/rot   | Status display LED green/yellow/red  |  |                                     |
| Potenzialfreier Sammelgang (strombegrenzt) Summenstrom für Signalausgänge: Alarm / Bat. Mode / Bat. Charge) | Potential-free summation input (short circuit proof summation-current for signal outputs: Alarm / Bat. Mode / Bat. Charge) | max. 30 V / 200 mA   |                                     |
| Signalausgang "Alarm"   | „Signal output "Alarm"“  | max. 30 V  |                                     |
| Relaiskontakt offen: Störung/Austausch Batteriemodul  | Relay-contact opens: Alarm / Exchange Battery  |  |                                     |
| Signaloptionen konfigurierbar über Schnittstelle  | Signal options are adjustable via interface  |  |                                     |
| Signalausgang "Bat. Mode"   | „Signal output "Bat. Mode"“  | max. 30 V  |                                     |
| Relaiskontakt geschlossen: Batteriebetrieb  | Relay-contact closed: buffer mode  |  |                                     |
| Ausgang konfigurierbar über Schnittstelle   | Signal options are adjustable via interface  |  |                                     |
| Signalausgang "Bat. Charge"   | „Signal output "Bat. Charge"“  | max. 30 V  |                                     |
| Relaiskontakt geschlossen: Batterie wird geladen  | Relay-contact closed: battery charging   |  |                                     |
| Ausgang konfigurierbar über Schnittstelle   | Signal options are adjustable via interface  |  |                                     |
| Anschlüsse Signalisierung   | Terminals signaling  | Push-In, max. 2,5 mm <sup>2</sup>  |                                     |
| <b>Umwelt</b>   |  | <b>Environment</b>   |                                     |
| Lagertemperatur   | Storage temperature  | -25 °C ... +85 °C  |                                     |
| Umgebungstemperatur   | Operational temperature  | -25 °C ... +70 °C  |                                     |
| Derating  | Derating   | Anlauf bei -40 °C typgeprüft Device start at -40 °C type-tested                  |                                     |
| Konvektionskühlung  | Convection cooling   | -1,5 % / K > +50 °C (90-264 Vac)   |                                     |
| Luftfeuchtigkeit, keine Betauung  | Humidity, no condensation  | -1,33% / K > +55 °C (180-264 Vac)  |                                     |
| Erforderlicher Mindestabstand (seitlich)  | Required minimum spacing (left/right)  | 5 ... 96 mm  |                                     |
| Erforderlicher Mindestabstand (oben/unten)  | Required minimum spacing (over/under)  | 0 mm   |                                     |
| <b>Allgemeine Daten</b>   |  | <b>General data</b>  |                                     |
| Schutzart nach IEC 60529  | Degree of protection acc. to IEC 60529   | IP 20  |                                     |
| Schutzklasse nach EN 61140  | Protection class acc. to EN 61140  | I  |                                     |
| Einsetz in Bereichen mit Verschmutzungsgrad 2   | For installation in Pollution Degree 2 environment   |  |                                     |
| Zum Anschluss Kupferkabel mit min. 75 °C verwenden  | Use Copper Conduction only, rated 75 °C  |  |                                     |
| Überspannungskategorie  | Over voltage category  | II   |                                     |
| <b>Normen</b>   |  | <b>Safety standards</b>  |                                     |
| Sicherheit  | Safety   | IEC 61010-1, IEC 61010-2-201, EN 61558-2-16, EN 62368-1, EN 60335-1              |                                     |
| EMV   | EMC  | EN 61204-3   |                                     |
| Schutzkleinspannung (SELV/PELV)   | Safety extra-low voltage (SELV/PELV)   | EN 61010-1 (SELV), EN 61010-2-201 (PELV)   |                                     |
| CE gemäß 2014/30/EU   | CE acc. to 2014/30/EU  |  |                                     |
| <b>Prüfzeichen</b>  |  | <b>Markings</b>  |                                     |
| UL  | UL   | UL 61010-1, UL 61010-2-201*  |                                     |
| DNV   | DNV  | in Vorbereitung / In preparation   |                                     |
| <b>Mechanische Daten</b>  |  | <b>Measures and weights</b>  |                                     |
| Befestigung auf Normprofilsschiene DIN EN 60715-TH35-15/ 7,5  | Mounting on standard rail DIN EN 60715-TH35-15/ 7,5  |  |                                     |
| Gewicht   | Weight   | 0,75 kg  | 0,95 kg                             |
| Maße (B x H x T) Tiefe inklusive TH 35-7,5-DIN-Schiene  | Dimensions (W x H x D) Depth including TH rail   | 55x127x126mm   | 63x127x136mm                        |
| Bestellnummern  | Order Number   |  |                                     |
| Kombi-USV   | Combi-UPS  | PCC-1024-050-20  | PCC-1024-100-20                     |

\*UL Note: The boost shall be followed by a recovery time (< nominal load) to prevent the equipment to exceed the max rated output power.  
Maximum continuous overall current 5,5A / 11A  
Nominal input voltage: 100-240 Vac

## 7.2 PCC-1024-050/100-2U

deutsch

english

### Technische Daten

### Technical data

| Eingangsdaten   |   | Input data  |                         | PCC-1024-050-2U  | PCC-1024-100-2U                     |
|---|---|---|-------------------------|--|-------------------------------------|
| Eingangsnennspannung  |   | Nominal input voltage   |                         | 100 - 240 Vac (100 - 240 Vdc)*   |                                     |
| Eingangsspannungsbereich  |   | Input voltage range   |                         | 90 - 264 Vac (90 - 264 Vdc)*   |                                     |
| Nennfrequenzbereich   |   | Frequency range   |                         | 47 Hz - 63 Hz / 0 Hz   |                                     |
| Eingangsstrom (bei Nennlast und Batterie ist geladen / Max.)  |   | Input current (mains operation and battery is charged / max.)   |                         | 2.00 A (100 Vac) / 0.95 A (230 Vac)                                    | 2.60 A (100 Vac) / 1.20 A (230 Vac) |
| Eingangsstrom (bei Nennlast und Batterie wird geladen / Max.)   |   | Input current (at nominal load and battery is being charged / max.)   |                         | 2.60 A (100 Vac) / 1.20 A (230 Vac)                                    | 3.30 A (100 Vac) / 1.40 A (230 Vac) |
| Einschaltstrombegrenzung  |   | Inrush current limitation   |                         | < 30 A, NTC  |                                     |
| Eingangssicherung, intern (Geräteschutz)  |   | Input fuse, internal (device protection)  |                         | 6.3 A  |                                     |
| Vorgeschriebene Vorsicherung, Leitungsschutzschalter (Charakteristik)   |   | Required back-up fuse, circuit breaker (characteristic)   |                         | 6 A, 10 A, 16 A (B,C)  |                                     |
| Transientenüberspannungsschutz  | Varistor  | Transient surge voltage protection  |                         |  |                                     |
| Anschlüsse Eingang  |   | Terminals input   |                         | Push-In, max. 2.5mm <sup>2</sup> (see Fig. 5)                          |                                     |
| Ausgangsdaten allgemein   |   | Output data   |                         |  |                                     |
| Ausgangsnennstrom   |   | Nominal output current  |                         | 5 A  | 10 A                                |
| Ausgangsstrom Boost (5s)*   |   | Output current boost (5s)*  |                         | 7.5 A  | 15 A                                |
| Ausgangsstrom Boost (kontinuierlich bis 45 °C / 100-264 Vac / 120-372 Vdc)  |   | Output current boost (continuous up to 45 °C / 100-264 Vac / 120-372 Vdc)   |                         | 5.5 A  | 11 A                                |
| Auslösen von Leitungsschutzschaltern  |   | Tripping of standard circuit breaker  |                         | max. B4  |                                     |
| Parallelschaltbarkeit zur Erhöhung der Systemverfügbarkeit  |   | Parallel connection to gain a higher system reliability   |                         | , only with additional redundancy module for decoupling                |                                     |
| Restwelligkeit  |   | Ripple/noise  |                         | typ. 50 mVss   |                                     |
| Rückspießfestigkeit   |   | Resistance to reverse feed  |                         | max. 35 Vdc  |                                     |
| Überspannungsschutz des Ausgangs (OVP)  |   | Over-voltage protection   |                         | typ. 38 Vdc  |                                     |
| Anschlüsse Ausgang  |   | Terminals output  |                         | Push-In, max. 2.5mm <sup>2</sup> (see Fig. 5)                          |                                     |
| Ausgangsdaten Netzbetrieb   |   | Output data in mains operation  |                         |  |                                     |
| Ausgangsnennspannung  |   | Nominal output voltage  |                         | 24 Vdc ± 1%  |                                     |
| Ausgangsspannungsbereich  |   | Output voltage range  |                         | 23 - 28.5 Vdc  |                                     |
| Ausgangsstrombegrenzung   | Konstantstrom   | Output current limitation constant current  | typ. 6.5 A              |  | typ. 13 A                           |
| Verlustleistung (Nennlast und Batterie geladen)   |   | Power losses (nominal load, battery charged)  | 21 W / 15 W             |  | 24.7 W / 17 W                       |
| Wirkungsgrad (Nennlast und Batterie geladen)  |   | Efficiency (nominal load, battery charged)  | typ. 89 %               |  | typ. 93 %                           |
| max. Verlustleistung (Batterie wird geladen)  |   | Maximum power losses (battery is charging)  |                         | 30 W (90 Vac)  |                                     |
| Ausgangsdaten Batteriebetrieb   |   | Output data in battery operation  |                         |  |                                     |
| Ausgangsnennspannung (abhängig von der Batteriespannung)  |   | Nominal output voltage (depends on the battery voltage)   |                         | 24 Vdc   |                                     |
| Ausgangsspannungsbereich  |   | Output voltage range  |                         | UBAT - 0.5 V (27.5 - 19 Vdc)   |                                     |
| Ausgangsstrombegrenzung   | elektronisch  | Output current limitation electronic  | typ. 5.5 A              |  | typ. 11 A                           |
| max. Verlustleistung (Leerlauf/ Nennlast)   |   | Max. power losses (stand-by/nominal load)   | 3.2 W                   |  | 5.2 W                               |
| Fernabschaltung   |   | Remote shut-down  |                         |  |                                     |
| Aufschalten kapazitiver Lasten  |   | Connection of capacitive loads  |                         | max. 10.000 µF   |                                     |
| einstellbare Pufferzeit   |   | Adjustable buffer time  |                         | 1, 2, 3, 5, 10, 15, 20 Min. PC-Mode, Maximum, adjustable via interface |                                     |
| Batteriemangement   |   | Battery management  |                         |  |                                     |
| Verpolungsschutz  | Sicherung im Batteriemodul löst aus   | Reverse connection protection (fuse of battery module will be tripped)  |                         |  |                                     |
| Ladecharakteristik  |   | Charging characteristic   |                         | IUoU   |                                     |
| Ladestrom   |   | Charging current  | 0.3 ... 2.0 A           |  | 0.3 ... 3.0 A                       |
| Ladeschlussspannung   | temperatur kompensiert  | End-of-charge voltage compensated temperature   | 26 ... 29.5 V           |  |                                     |
| Zyklus für Batteriepräsenprüfung  | 60 Sekunden   | Battery presence check time interval  |                         |  |                                     |
| Zyklus für Restlebensdauerprüfung   | 10 Minuten  | Battery presence check time interval  | 10 minutes              |  |                                     |
| Tiefentladeschutz   |   | Protection against total discharge  |                         | 19 V   |                                     |
| Schwelle Warnmeldung "Batteriespannung sehr gering"   |   | "Battery voltage very low" alarm signaling threshold  |                         | 20.4 V   |                                     |
| empfohlene Batteriemodule   |   | Recommended battery modules   | 0.8 ... 7 Ah            |  | 3.2 ... 12 Ah                       |
| *Parallelschaltung von Batteriemodulen / Max. 3 zur Verlängerung der Pufferzeit (Beide Steuerleitungen sind nur an einem Batteriemodul anzuschließen) |   | *Parallel connection of batteries / Max. 3 to increase the buffer time (Both control-lines should be connected to only one of the battery module) |                         |  |                                     |
| Leakstrom   |   | Leakage current   |                         | < 0.1 mA   |                                     |
| Signalisierung  |   | Signaling   |                         |  |                                     |
| Statusanzeige LED grün/gelb/rot   |   | Status display LED green/yellow/red   |                         |  |                                     |
| Potenzialfreier Summeingang (strombegrenzter Summenstrom für Signalausgänge: Alarm / Bat. Mode / Bat. Charge)   |   | Potential-free summation input (short circuit proof summation-current for signal-outputs: Alarm / Bat. Mode / Bat. Charge)                        |                         | max. 30 V / 200 mA   |                                     |
| Signalausgang "Alarm"   | Relaiskontakt offen: Störung/ Austausch Batteriemodul<br>Signaloptionen konfigurierbar über Schnittstelle | ,Signal output "Alarm"<br>Relay-contact opens: Alarm / Exchange Battery<br>Signal options are adjustable via interface                            |                         | max. 30 V  |                                     |
| Signalausgang "Bat. Mode"   | Relaiskontakt geschlossen: Batteriebetrieb<br>Ausgang konfigurierbar über Schnittstelle                   | ,Signal output "Bat. Mode"<br>Relay-contact closed: buffer mode<br>Signal options are adjustable via interface                                    |                         | max. 30 V  |                                     |
| Signalausgang "Bat. Charge"   | Relaiskontakt geschlossen: Batterie wird geladen<br>Ausgang konfigurierbar über Schnittstelle             | ,Signal output "Bat. Charge"<br>Relay-contact closed: battery charging<br>Signal options are adjustable via interface                             |                         | max. 30 V  |                                     |
| Anschlüsse Signalisierung   |   | Terminals signaling   |                         | Push-In, max. 2.5mm <sup>2</sup>                                       |                                     |
| Schnittstelle   |   | Interface   |                         |  |                                     |
| USB   |   | USB   |                         | USB Typ B  |                                     |
| Umwelt  |   | Environment   |                         |  |                                     |
| Lagertemperatur   |   | Storage temperature   |                         | -25 °C ... +5 °C   |                                     |
| Umgebungstemperatur   |   | Operational temperature   |                         | -25 °C ... +70 °C  |                                     |
| Derating  |   | Derating  |                         | Anlauf bei -40 °C typgeprüft. Device start at -40 °C type-tested       |                                     |
| Konvektionskühlung  |   | Convection cooling  |                         | -1.5 % / K > +50 °C (90-264 Vac)                                       |                                     |
| Luftfeuchtigkeit, keine Betauung  |   | Humidity, no condensation   |                         | -1.33 % / K > +55 °C (180-264 Vac)                                     |                                     |
| Erforderlicher Mindestabstand (seitlich)  |   | Required minimum spacing (left/right)   |                         | 5 ... 96%  |                                     |
| Erforderlicher Mindestabstand (oben/unten)  |   | Required minimum spacing (over/under)   |                         | 0 mm   |                                     |
| Allgemeine Daten  |   | General data  |                         |  |                                     |
| Schutzart nach IEC 60529  |   | Degree of protection acc. to IEC 60529  |                         | IP20   |                                     |
| Schutzklasse nach EN 61140  |   | Protection class acc. to EN 61140   |                         | I  |                                     |
| Einsatz in Bereichen mit Verschmutzungsgrad 2   |   | For installation in Pollution Degree 2 environment  |                         |  |                                     |
| Zum Anschluss Kupferkabel mit min. 75 °C verwenden  |   | Use Copper Conductor only, rated 75 °C  |                         |  |                                     |
| Überspannungskategorie  |   | Over voltage category   |                         | II   |                                     |
| Normen  |   | Safety standards  |                         |  |                                     |
| Sicherheit  |   | Safety  |                         | IEC 61010-1, IEC 61010-2-201, EN 61558-2-16, EN 62368-1, EN 60335-1    |                                     |
| EMV   |   | EMC   |                         | EN 61204-3   |                                     |
| Schutzkleinspannung (SELV/PELV)   |   | Safety extra-low voltage (SELV/PELV)  |                         | EN 61010-1 (SELV), EN 61010-2-201 (PELV)                               |                                     |
| CE gemäß 2014/30/EU   |   | CE acc. to 2014/30/EU   |                         |  |                                     |
| Prüfzeichen   |   | Markings  |                         |  |                                     |
| UL  |   | UL  |                         | UL 61010-1, UL 61010-2-201*  |                                     |
| DNV   |   | DNV   |                         | in Vorbereitung pending  |                                     |
| Mechanische Daten   |   | Measures and weights  |                         |  |                                     |
| Befestigung auf Normprofilsschiene DIN EN 60715-TH35-15/7.5   |   | Mounting on standard rail DIN EN 60715-TH35-15/7.5  |                         |  |                                     |
| Gewicht   |   | Weight  |                         | 0.75 kg  | 0.95 kg                             |
| Maße (B x H x T)  | Tiefe inklusive TH 35-7.5-DIN-Schiene   | Dimensions (W x H x D)  | Depth including TH rail | 55 x 127 x 126 mm  | 63 x 127 x 166 mm                   |
| Bestellnummern  |   | Order Number  |                         |  |                                     |
| Kombi-USV   |   | Combi-UPS   |                         | PCC-1024-050-2U  | PCC-1024-100-2U                     |

\*UL Note: The boost shall be followed by a recovery time (< nominal load) to prevent the equipment to exceed the max rated output power.  
Maximum continuous overall current 5.5A / 11A  
Nominal input voltage: 100-240 Vac