

# User Manual

Temperature Controllers

## **TM Series**

MCT-TMU1-V3.6-EN

Thank you for purchasing an Autonics product.  
This user manual contains information about the product and its proper use,  
and should be kept in a place where it will be easy to access.

**[www.autonics.com](http://www.autonics.com)**

**Autonics**



# Preface

Thank you for purchasing an Autonics product.





Please familiarize yourself with the information contained in the Safety Precautions section before using this product.

This user manual contains information about the product and its proper use, and should be kept in a place where it will be easy to access.

# User Manual Guide

- Please familiarize yourself with the information in this manual before using the product.
- This manual provides detailed information on the product's features. It does not offer any guarantee concerning matters beyond the scope of this manual.
- This manual may not be edited or reproduced in either part or whole without permission.
- A user manual is not provided as part of the product package.  
Visit our web site ([www.autonics.com](http://www.autonics.com)) to download a copy.
- The manual's content may vary depending on changes to the product's software and other unforeseen developments within Autonics, and is subject to change without prior notice.  
Upgrade notice is provided through out homepage.
- We contrived to describe this manual more easily and correctly. However, if there are any corrections or questions, please notify us these on our homepage.

# User Manual Symbols

Symbol	Description
 <b>Note</b>	Supplementary information for a particular feature.
 <b>Warning</b>	Failure to follow instructions can result in serious injury or death.
 <b>Caution</b>	Failure to follow instructions can lead to a minor injury or product damage.
 <b>Ex.</b>	An example of the concerned feature's use.
※1	Annotation mark.

# Safety Considerations

- Following these safety precautions will ensure the safe and proper use of the product and help prevent accidents, as well as minimizing possible hazards.
- Safety precautions are categorized as Warnings and Cautions, as defined below:

 <b>Warning</b>	<b>Warning</b>	Failure to follow the instructions may lead to a serious injury or accident.
--	----------------	--

 <b>Caution</b>	<b>Caution</b>	Failure to follow the instructions may lead to a minor injury or accident.
--	----------------	--

## Warning

- Fail-safe device must be installed when using the unit with machinery that may cause serious injury or substantial economic loss. (e.g. nuclear power control, medical equipment, ships, vehicles, railways, aircraft, combustion apparatus, safety equipment, crime/disaster prevention devices, etc.)  
Failure to follow this instruction may result in personal injury, economic loss or fire.
- Do not use or store the unit in the place where flammable/explosive/corrosive gas, high humidity, direct sunlight, radiant heat, vibration, impact or salinity may be present.  
Failure to follow this instruction may result in explosion or fire.
- Install the device in panel to use.  
Failure to follow this instruction may result in fire.
- Do not connect, repair, or inspect the unit while connected to a power source.  
Failure to follow this instruction may result in fire.
- Check 'Connections' before wiring.  
Failure to follow this instruction may result in fire.
- Do not disassemble or modify the unit.  
Failure to follow this instruction may result in fire.

## Caution

- When connecting the power input and relay output, use AWG 26 to 12 cable, and connecting the sensor input and communication cable without dedicated cable, use AWG 28 to 14cable.  
Failure to follow this instruction may result in fire or malfunction due to contact failure.
- Use the unit within the rated specifications.  
Failure to follow this instruction may result in fire or product damage.
- Use a dry cloth to clean the unit, and do not use water or organic solvent.  
Failure to follow this instruction may result in fire or electric shock.
- Keep the product away from metal chip, dust, and wire residue which flow into the unit.  
Failure to follow this instruction may result in fire or product damage.

# Caution during Use

- Follow instructions in 'Cautions during Use'. Otherwise, It may cause unexpected accidents.
- Check the polarity of the terminals before wiring the temperature sensor.  
For RTD temperature sensor, wire it as 3-wire type, using cables in same thickness and length.  
For thermocouple (CT) temperature sensor, use the designated compensation wire for extending wire.
- Keep away from high voltage lines or power lines to prevent inductive noise.  
In case installing power line and input signal line closely, use line filter or varistor at power line and shielded wire at input signal line.  
Do not use near the equipment which generates strong magnetic force or high frequency noise.
- Do not apply excessive power when connecting or disconnecting the connectors of the product.
- Install a power switch or circuit breaker in the easily accessible place for supplying or disconnecting the power.
- Do not use the unit for other purpose (e.g. voltmeter, ammeter), but temperature controller.
- When changing the input sensor, turn off the power first before changing.  
After changing the input sensor, modify the value of the corresponding parameter.
- Power supply should be insulated and limited voltage/current or Class 2, SELV power supply device.
- Do not overlapping communication line and power line.  
Use twisted pair wire for communication line and connect ferrite bead at each end of line to reduce the effect of external noise.
- Make a required space around the unit for radiation of heat.  
For accurate temperature measurement, warm up the unit over 20 min after turning on the power.
- Make sure that power supply voltage reaches to the rated voltage within 2 sec after supplying power.
- Do not wire to terminals which are not used.
- Install DIN rail vertically from the ground.
- This unit may be used in the following environments.
  - ①Indoors (in the environment condition rated in 'Specifications')
  - ②Altitude max. 2,000m
  - ③Pollution degree 2
  - ④Installation category II

**The above specifications are subject to change and some models may be discontinued without notice.**

**Be sure to follow cautions written in the instruction manual, user manual and the technical descriptions (catalog, homepage).**



# Table of Contents

	Preface 3	
	User Manual Guide .....	4
	User Manual Symbols .....	5
	Safety Considerations .....	6
	Caution during Use.....	7
	Table of Contents .....	9
<b>1</b>	<b>Product Introduction.....</b>	<b>13</b>
	1.1 Features .....	13
	1.2 Components and accessories.....	14
	1.3 Ordering Information .....	18
	1.3.1 Model list and descriptions.....	19
	1.4 Parts and features.....	20
	1.4.1 Front parts.....	20
	1.4.2 Other parts .....	22
<b>2</b>	<b>Specifications.....</b>	<b>23</b>
<b>3</b>	<b>Dimensions.....</b>	<b>25</b>
	3.1 Installation .....	25
	3.1.1 Connector connection .....	25
	3.1.2 Module connection .....	26
	3.1.3 Mounting with bolts .....	27
	3.1.4 Mounting on DIN rail .....	27
<b>4</b>	<b>Connections and Insulation Block Diagram .....</b>	<b>29</b>
	4.1 TM2 Series .....	29
	4.2 TM4 Series .....	30
	4.3 Wiring precautions.....	31
	4.3.1 Sensor connection .....	31
	4.3.2 Power supply connection .....	32
	4.3.3 Communication line wiring .....	32
	4.3.4 Module connection .....	33
<b>5</b>	<b>Preparation and Startup .....</b>	<b>35</b>
	5.1 General process.....	35
	5.2 Setup values when power ON.....	35
	5.3 Temperature control examples.....	36
	5.3.1 Single module.....	36
	5.3.2 Multiple modules .....	38
<b>6</b>	<b>Parameter Settings and Functions .....</b>	<b>39</b>
	6.1 Input .....	39
	6.1.1 Input type and temperature range.....	39
	6.1.2 Input type.....	40

6.1.3	Input temperature sensor unit .....	40
6.1.4	Input correction.....	41
6.1.5	Input digital filter .....	41
6.1.6	SV high/low-limit value .....	42
6.2	Control output.....	43
6.2.1	Control output operation mode.....	43
6.2.2	Dead band/Overlap band .....	45
6.2.3	MV high/low-limit value.....	49
6.2.4	Ramp function .....	50
6.2.5	Auto/Manual control .....	52
6.2.6	Manual control baseline MV .....	52
6.2.7	Manual control initial MV .....	53
6.2.8	Control output.....	53
6.3	Temperature control .....	54
6.3.1	Temperature control method .....	54
6.3.2	ON/OFF control .....	54
6.3.3	PID control.....	55
6.3.4	Auto-tuning .....	58
6.4	Alarm output .....	60
6.4.1	Alarm output target channel .....	60
6.4.2	Alarm output operating mode.....	61
6.4.3	Alarm output option .....	62
6.4.4	Alarm SV .....	63
6.4.5	Alarm output hysteresis.....	64
6.4.6	Alarm output method .....	64
6.4.7	Alarm output delay .....	65
6.4.8	Loop break alarm(LBA) .....	66
6.4.9	Sensor break alarm.....	69
6.4.10	Heater burnout alarm .....	69
6.4.11	Alarm output OFF.....	71
6.4.12	Alarm output examples.....	72
6.5	Communications.....	75
6.5.1	Communications speed settings .....	76
6.5.2	Communications parity bit.....	76
6.5.3	Communication stop bit.....	77
6.5.4	Response wait time .....	77
6.5.5	Enable/Disable communications writing.....	77
6.5.6	Communication Protocol .....	77
6.5.7	USB-to-Serial connection .....	78
6.6	Monitoring function .....	79
6.6.1	Control output MV monitoring .....	79
6.6.2	Heating MV monitoring.....	79
6.6.3	Cooling MV monitoring.....	79
6.6.4	Heater current monitoring.....	79
6.7	Run/Stop function .....	80
6.7.1	Control output for STOP .....	80
6.7.2	Alarm output for STOP .....	80
6.8	Multi SV .....	81

6.8.1	Number of multi SVs .....	81
6.8.2	Multi SV No. settings .....	81
6.8.3	SV for Multi SVs .....	81
6.9	Digital input.....	82
6.9.1	Digital input terminal settings .....	82
6.9.2	Digital input terminal target channel.....	82
6.10	Error .....	83
6.10.1	Sensor error, MV setting .....	83
6.11	Parameter initialization .....	84
<b>7</b>	<b>Simple Error Diagnosis .....</b>	<b>85</b>
7.1	Error display .....	85
7.2	Trobleshootings.....	85
<b>8</b>	<b>DAQMaster .....</b>	<b>87</b>
8.1	Overview .....	87
8.2	Features .....	88
8.3	Firmware version.....	89



# 1 Product Introduction

## 1.1 Features

TM Series module type temperature controller realizes high-speed controlling with superior sampling cycle (TM4 – 100 ms, TM2 – 50 ms). Side connector connection makes less wiring work and close mounting possible for up to 31 units without additional power and communication wires for expansion modules. PC parameter setting and monitoring is possible via RS485 communication or dedicated USB cable. In addition, more reliable temperature controlling can be realized via various convenient functions.

- Multi channels (4-CH/2-CH) simultaneous controlling possible
- Each channel insulated – Dielectric strength 1,000VAC
- No communication and power supply for expansion modules required using module connectors : Up to 31 module (124 channels/62 channels) expansion possible
- High-speed sampling cycle (100ms/50ms)
- Heating/Cooling simultaneous controlling
- Heater burn-out detection via a current transformer (CT).
- PC parameter setting via PC (USB cable and RS485 communication)
  - : Supports comprehensive device management program (DAQMaster)
  - ※ Communication converter, sold separately
  - : SCM-WF48 (Wi-Fi to RS485-USB wireless communication converter),  
SCM-US48I (USB to RS485 converter), SCM-38I (RS232C to RS485 converter),  
SCM-US (USB to serial converter)
  - : Enables to set parameters via SCM-US which does not required supplying power and wiring
- Easy maintenance via connector type connection
  - : Sensor input connector, control output connector, power/communication connector
- Multi-input/multi-range
- Heater disconnection alarm (CT function)
  - ※ CT, sold separately: CSTC-E80LN, CSTC-E200LN, CSTS-E80PP

## 1.2 Components and accessories

### (1) Components

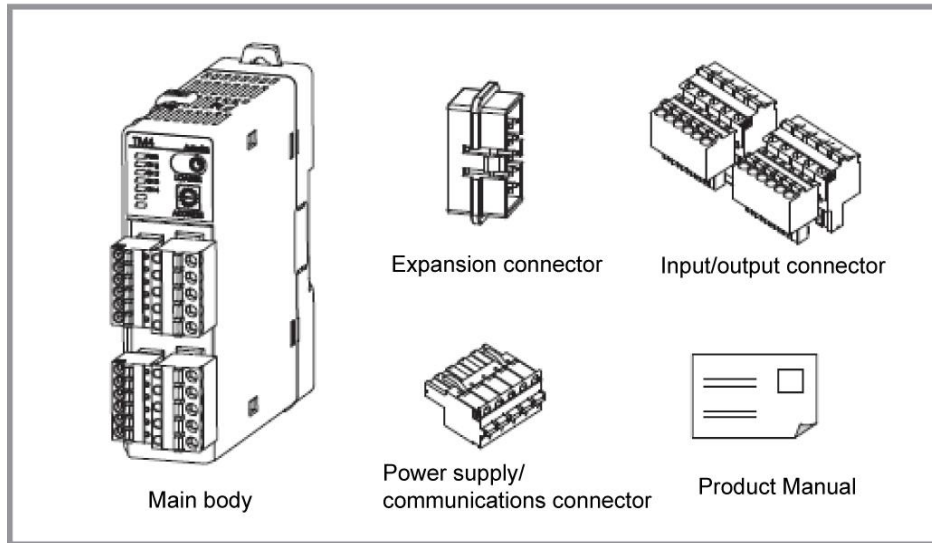

### Note

- Make sure all listed components are included with your product before use. If any components are missing or damaged, please contact our sales department or your dealer.
- Note that power supply/communications connectors are provided with basic modules only.

**(2) Accessories (sold separately)**

- Current transformer(CT)

CSTC-E80LN

- Max. load current: 80A(50/60Hz)  
 ※Max. load current for TM Series is 50A.
- Current ratio: 1/1000
- Wire wounded resistance:  $31\Omega \pm 10\%$

(unit: mm)

OUTPUT IN VOLTS RMS(V)

SENSED CURRENT IN AMPS RMS(I<sub>0</sub>)

F=50Hz

T<sub>a</sub>=25°C

100Ω

10Ω

CSTC-E200LN

- Max. load current: 200A(50/60Hz)  
 ※Max. load current for TM Series is 50A.
- Current ratio: 1/1000
- Wire wounded resistance:  $20\Omega \pm 10\%$

(unit: mm)

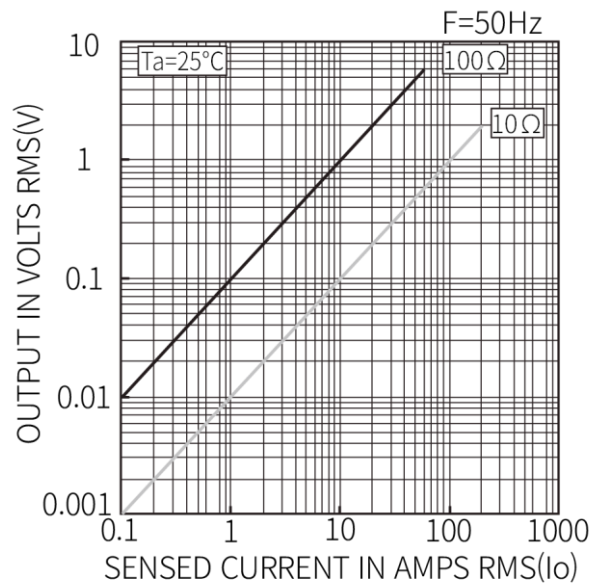
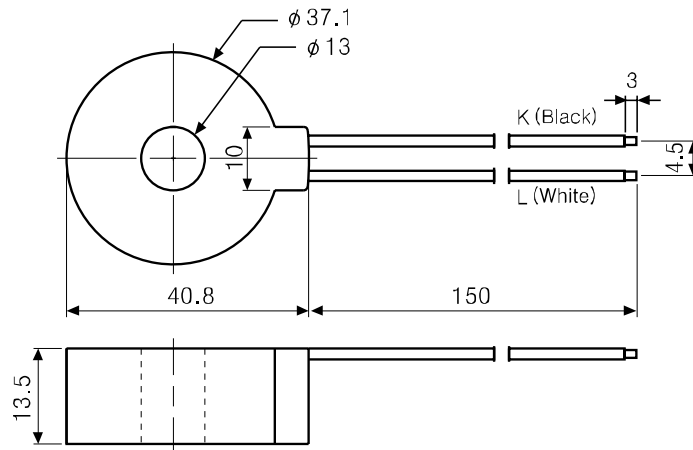

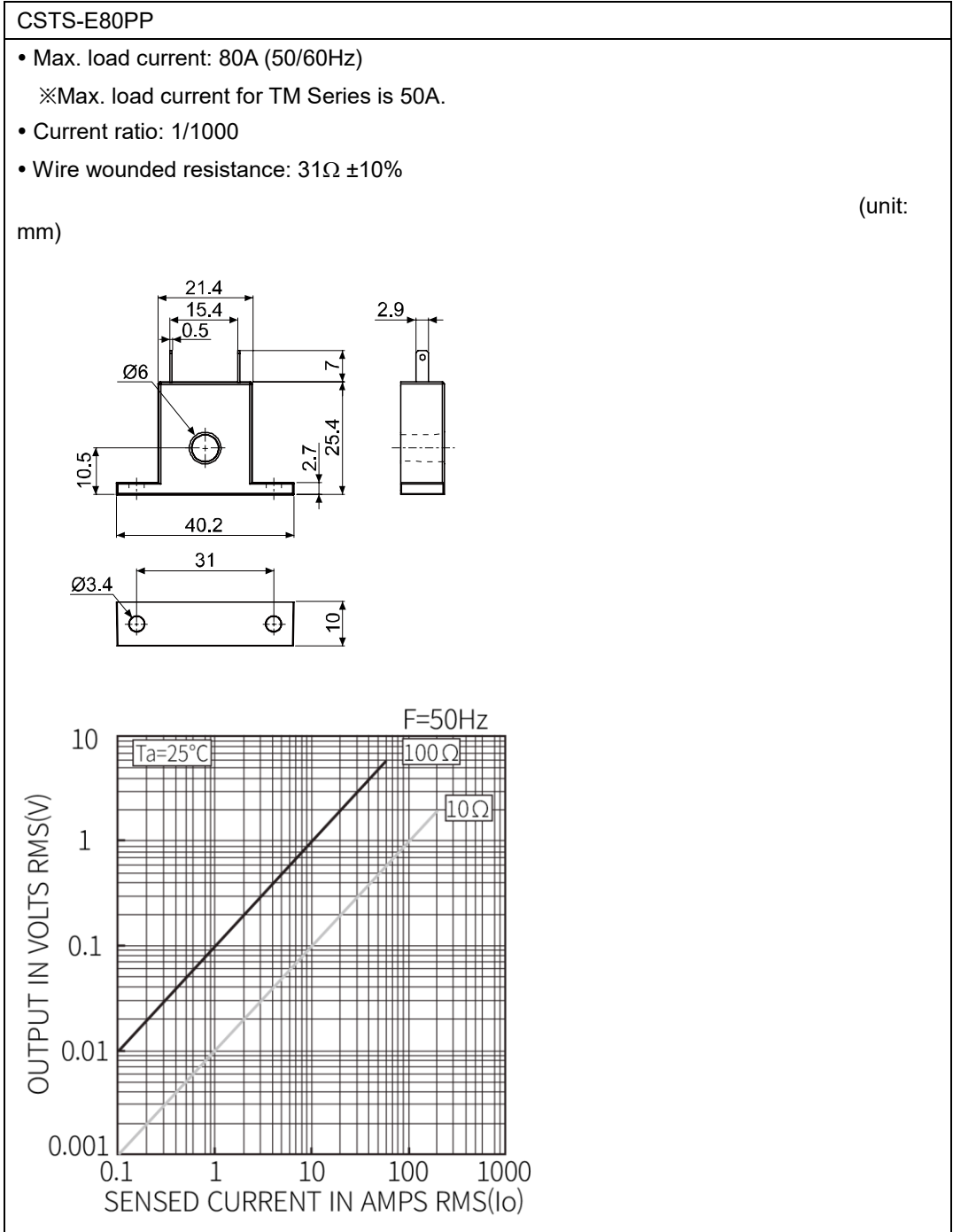

**Caution**

For using CT, do not supply first part current when opening CT output. It occurs high voltage at CT output part.

Using current of above CTs are same as 50A. But be sure that inner hole sizes are different. Select it properly for the environment.

## 1.3 Ordering Information

T	M	①	-	②	③	④	⑤
---	---	---	---	---	---	---	---

### ① Channel

2: 2 channels

4: 4 channels

### ② Alarm output

2: Alarm output 1/2 (2 channels)

4: Alarm output 1/2/3/4 (4 channels)

N: None (4 channels)

### ③ Power supply

2: 24 VDC

### ④ Control output

R: Relay

S: SSR drive

C: Selectable current or SSR drive output

### ⑤ Structure

B: Basic module

E: Expansion module<sup>※1</sup>

※1. Since the expansion module is not supplied with power/comm. terminal. Use it with the basic module.

### 1.3.1 Model list and descriptions

	Model Name	Control Output	Option Input/Output		Structure	
			Input	Output		
TM2 Series	TM2-22RB	Relay output	CT input, Digital input (DI-1, DI-2)	Alarm 1/2, RS485 comm. output	Basic module	
	TM2-22CB	Current or SSR drive output		Alarm 1/2, RS485 comm. output		
	TM2-42RB	Relay output		Alarm 1/2/3/4, RS485 comm. output		
	TM2-42CB	Current or SSR drive output		Alarm 1/2/3/4, RS485 comm. output		
	TM2-22RE	Relay output		-	Alarm 1/2, RS485 comm. output	Expansion module
	TM2-22CE	Current or SSR drive output			Alarm 1/2, RS485 comm. output	
	TM2-42RE	Relay output			Alarm 1/2/3/4, RS485 comm. output	
	TM2-42CE	Current or SSR drive output			Alarm 1/2/3/4, RS485 comm. output	
TM4 Series	TM4-N2RB	Relay output	-	RS485 comm. output	Basic module	
	TM4-N2SB	SSR drive output				
	TM4-N2RE	Relay output			Expansion module	
	TM4-N2SE	SSR drive output				

## 1.4 Parts and features

### 1.4.1 Front parts

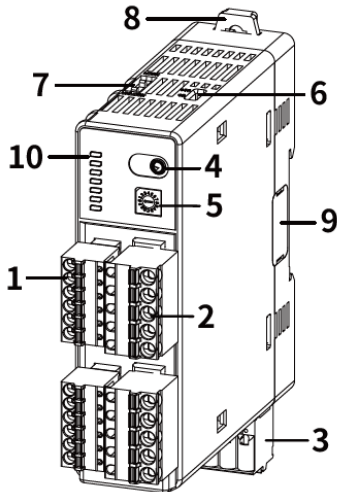

**1. Sensor input connector**

**2. Control output connector**

**3. Power/Comm. Terminal (Basic module)**

Refer to 'Connections' for the detail description about connector and terminal.

**4. PC loader port**

For serial communication between one module and PC to set parameter and monitoring by using communication converter.

**5. Communication address setting switch (SW1)**

**6. Communication address group switch (SW2)**

When setting the communication address over 16, select +16.

**7. Lock switch**

Used for fixing modules at top and bottom.

**8. Rail lock**

Used for installing at DIN rail or using bolts.

**9. END cover**

Remove it when connecting each module to connect an side connector for expansion.

## 10. Indicator

## TM2

Status Indicator	Initial power ON <sup>01)</sup>	Control output	Auto tuning <sup>02)</sup>	Alarm output			
				N.O.		N.C.	
				OFF	ON	OFF	ON
PWR (green) <sup>03)</sup>	ON	ON	ON	-			
CH1 (red)	Flash (4,800 bps)	ON	Flash				
CH2 (red)	Flash (9,600 bps)	ON	Flash				
AL1 (yellow)	Flash (19,200 bps)	ON <sup>04)</sup>	OFF	OFF	ON	OFF	ON
AL2 (yellow)	Flash (38,400 bps)	ON <sup>05)</sup>	OFF	OFF	ON	OFF	ON
AL3 (yellow)	Flash (57,600 bps)	-	OFF	OFF	ON	OFF	ON
AL4 (yellow)	Flash (115,200 bps)	-	OFF	OFF	ON	OFF	ON

## TM4

Status Indicator	Initial power ON <sup>01)</sup>	Control output	Auto tuning <sup>02)</sup>
PWR (green) <sup>03)</sup>	ON	ON	ON
CH1 (red)	Flash (4,800 bps)	ON	Flash
CH2 (red)	Flash (9,600 bps)	ON	Flash
CH3 (red)	Flash (19,200 bps)	ON	Flash
CH4 (red)	Flash (38,400 bps)	ON	Flash
- (yellow)	Flash (57,600 bps)	-	OFF
- (yellow)	Flash (115,200 bps)	-	OFF

01) When power is supplied initially, the set communication speed LED flashes for 5 sec.

02) The auto tuning CH LED flashes for 1 sec in turn.

03) The PWR LED flashes during communication for 1 sec in turn.

04) Turns ON when CH1 control method is heating & cooling control and cooling output occurs.  
(disable AL1 setting)

05) Turns ON when CH2 control method is heating & cooling control and cooling output occurs.  
(disable AL2 setting)

### 1.4.2 Other parts

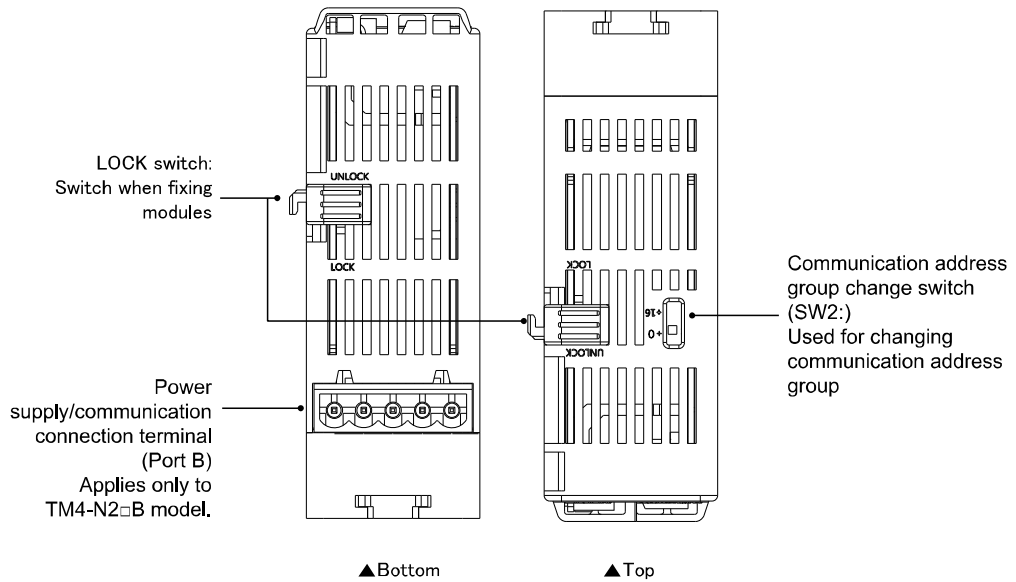
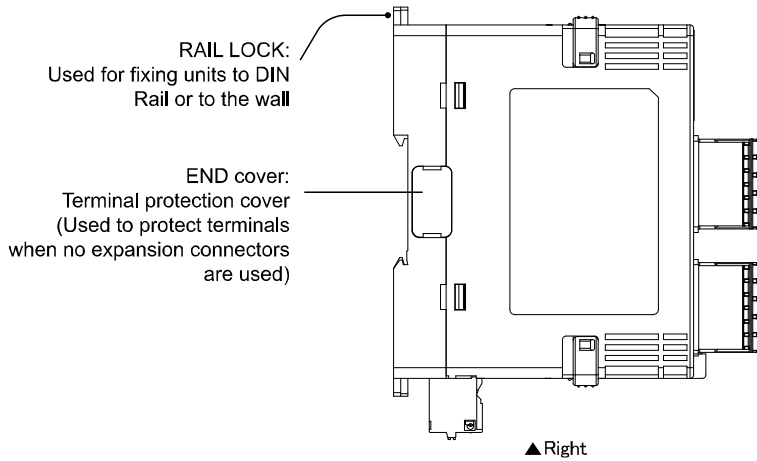

## 2 Specifications

Series		TM2	TM4
Number of channels		2 channels (insulated each channel – dielectric strength 1,000VAC)	4 channels (insulated each channel – dielectric strength 1,000VAC)
Power supply		24VDC	
Allowable voltage range		90 to 110% of rated voltage	
Power consumption		Max. 5W (for max. load)	
Display method		None- parameter setting and monitoring is available at external devices (PC, PLC, etc.)	
Input type	Thermocouple	K(CA), J(IC), E(CR), T(CC), B(PR), R(PR), S(PR), N(NN), C(TT), G, (TT), L(IC), U(CC), Platine II	
	RTD	JPt100 Ω, DPt100 / 50 Ω, Cu50 / 100 Ω, Nickel120 Ω (permissible line resistance max. 5Ω)	
Sampling period		50 ms (2 channel simultaneous sampling)	100 ms (4 channel simultaneous sampling)
Measured accuracy	Thermocouple <sup>※1</sup>	(PV ±0.5% or ±1°C, select the higher one) ±1-digit max.	
	RTD		
	CT input	±5% F.S. ±1-digit max.	-
	Current output	±1.5% F.S. ±1-digit max.	-
Influence of temp. <sup>※2</sup>	Thermocouple	(PV ±0.5% or ±2°C, select the higher one) ±1-digit max.	
	RTD	(Thermocouple input max. -100°C is within ±5°C) ●Thermocouple B, R, S, C, G, L, U: (PV ±0.5% or ±5°C, select the higher one) ±1-digit max.	
Control Output	Relay	250VAC 3A 1a	
	SSR	Max. 12VDC ±3V 30mA	Max. 22VDC ±3V 30mA
	Current	Selectable DC 4-20mA or DC 0-20mA (load resistance max. 500Ω)	-
Control type	Heating, Cooling	ON/OFF control, P, PI, PD, PID control	
	Heating & Cooling		
Option output	Alarm	250VAC 3A 1a	-
	Communication	RS485 communication output (Modbus RTU / ASCII method)	
Option input	CT input	0.0-50.0A (primary current measurement range) ※CT ratio: 1/1000	-
	Digital input	● Contact input: ON max. 1kΩ, OFF min. 100kΩ ● Solid-state input: ON residual voltage max. 1.5VDC□, OFF leakage current max. 0.1mA ● Outflow current: Approx. 0.5mA per input	-
Hysteresis		1 to 100°C/°F (0.1 to 100.0°C/°F) variable	

Series		TM2	TM4
Proportional band (P)		0.1 to 999.9°C/°F	
Integral time (I)		0 to 9999 sec	
Derivative time (D)		0 to 9999 sec	
Control period		0.1 to 120.0 sec (only relay and, SSR drive output type)	
Manual reset		0.0 to 100.0%	
Relay life cycle	Mechanical	Min. 10,000,000 operations	
	Electrical	Min. 100,000 operations (250VAC 3 A resistance load)	
Insulation resistance		100 MΩ (at 500VDC megger)	
Insulation type		Double insulation or reinforced insulation (mark: □, dielectric strength between measurement part and power part: 1kV)	
Dielectric strength		Between the charging part and the case: 3,000VAC 50/60Hz for 1 min	
Vibration		0.75mm amplitude at frequency of 5 to 55Hz in each X, Y, Z direction for 2 hours	
Noise resistance		±0.5kV the square wave noise (pulse width: 1 μs) by the noise simulator	
Environment	Ambient temperature	-10 to 50°C, storage: -20 to 60°C	
	Ambient humidity	35 to 85%RH, storage: 35 to 85%RH	
Accessories		Expansion connector: 1, Power/Comm. connector: 1 (only for basic module)	
Certification		CE, UKCA, UL, KC, EAC	
Weight <sup>※3</sup>	Basic module	Approx. 217g (Approx. 152g)	Approx. 239g (Approx. 174g)
	Expansion module	Approx. 208g (Approx. 143g)	Approx. 231g (Approx. 166g)

※1. In case of thermocouple K, J, E, T, N, it is below -100°C and L, U, Platinel II, RTD Cu50 Ω, DPt50 Ω, it is below PV ±2°C ±1-digit.

In case of thermocouple B, display accuracy cannot be ensured under 400°C.

In case of thermocouple R, S, it is below 200°C and C, G, it is max. ±3°C ±1-digit.

※2. Applied when it is for out of room temperature (23±5°C) range.

※3. The weight includes packaging. The weight in parenthesis is for unit only.

※Environment resistance is rated at no freezing or condensation.

### 3 Dimensions

(unit: mm)

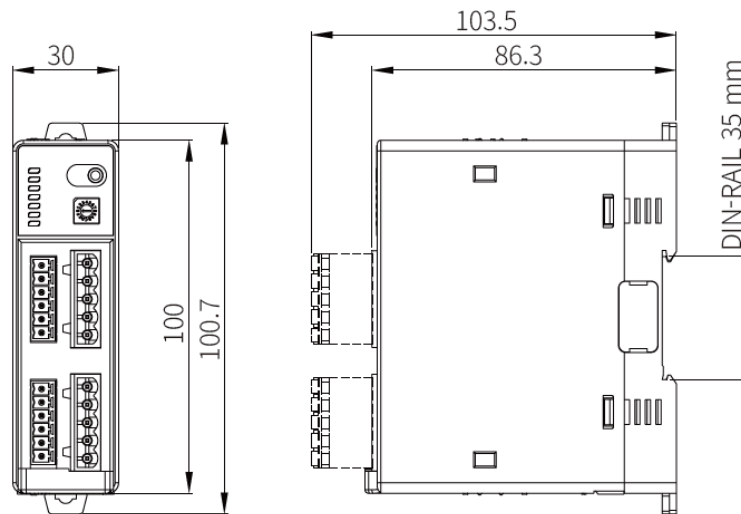

#### Note

Expansion modules do not have a power supply/communications connection terminal at the bottom.

### 3.1 Installation

#### 3.1.1 Connector connection

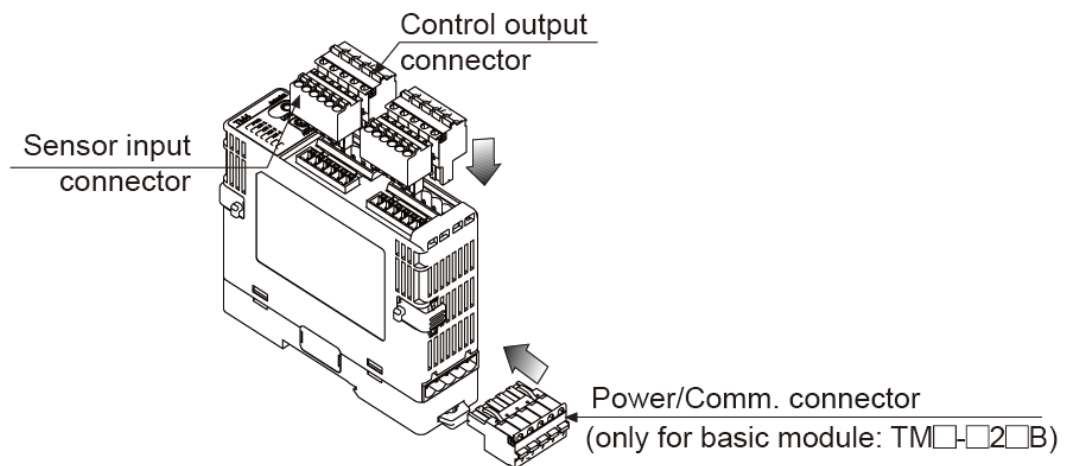

#### Note

Expansion modules do not have a power supply/communications connection terminal.

### 3.1.2 Module connection

TM Series allows simultaneous monitoring for multi channel I/O with connecting Multiple modules using module expansion connectors. Connect expansion modules to a basic module. Basic module can be placed in any position among multiple module sets. Remove the cover.

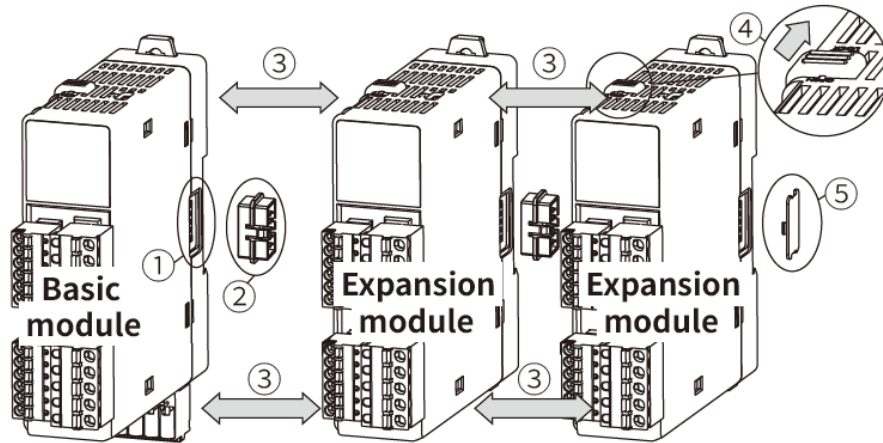

- 1st Remove each module's END covers. (do not remove at the ends of END covers)
- 2nd Connect expansion connectors between modules.
- 3rd Push each modules. (max. 30 units)
- 4th Push the lock switch to lock direction.



#### Note

- Supply adequate power for power input specifications and overall capacity. (Max. power when connecting 31 modules:  $31 \text{ units} \times 5\text{W} = 155\text{W}$ )
- Install the units vertically.

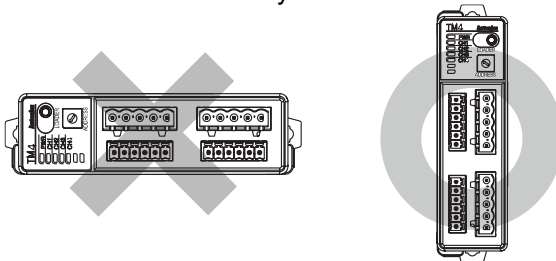

- Use end plates (sold separately, not available from Autonics) to fix firmly.

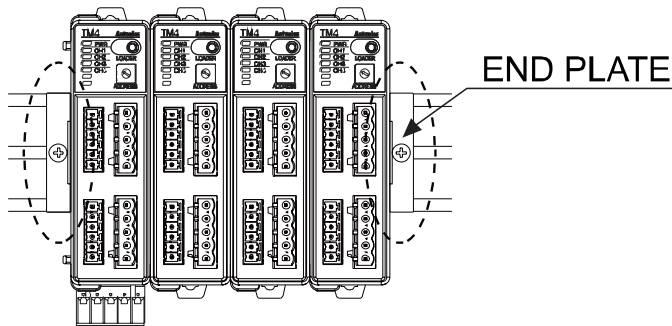

### 3.1.3 Mounting with bolts

1st Pull each rail lock to up and down.

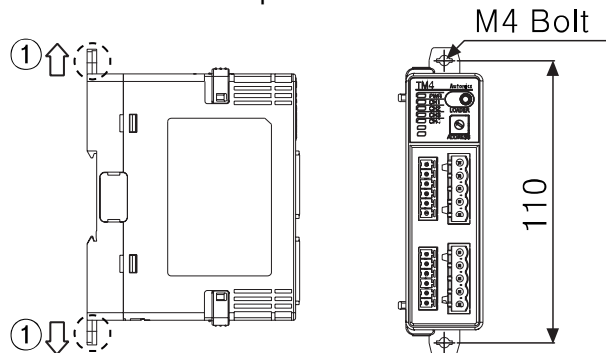

2nd Insert bolts to fix it on rail lock. (fixing torque is 0.5 to 0.9 N•m).

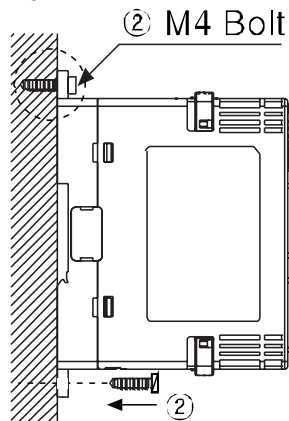

### 3.1.4 Mounting on DIN rail

#### (1) Installation/Removal method of a single module

- Installing

1st Hang the top rail lock to DIN rail.

2nd Push and press the module to down direction.

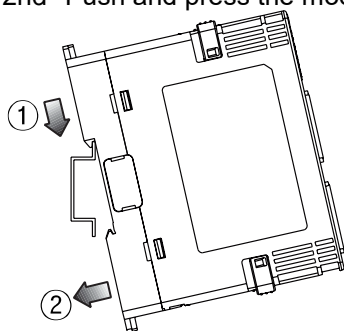

- Removing

1st Press the module to down direction.

2nd Pull the module body forward.

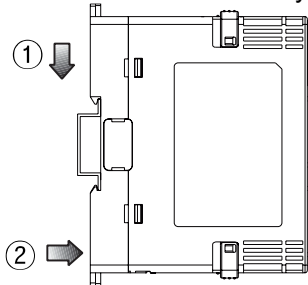

## (2) Installation/Removal method of multiple modules

- Installing

1st Pull each rail lock switch up and down.

2nd Mount the module body to the DIN rail and then push the rail lock in.

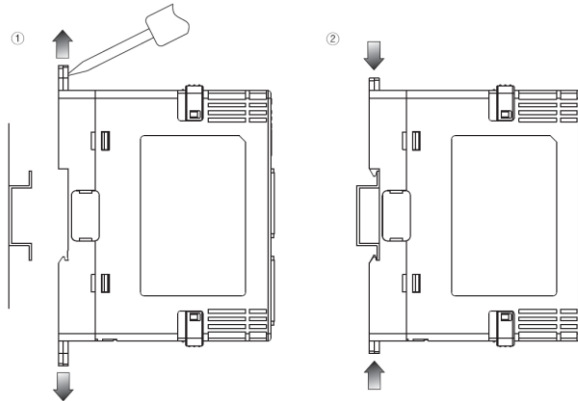

- Removing

1st Pull each rail lock switch up and down.

2nd Remove the body from the DIN rail.

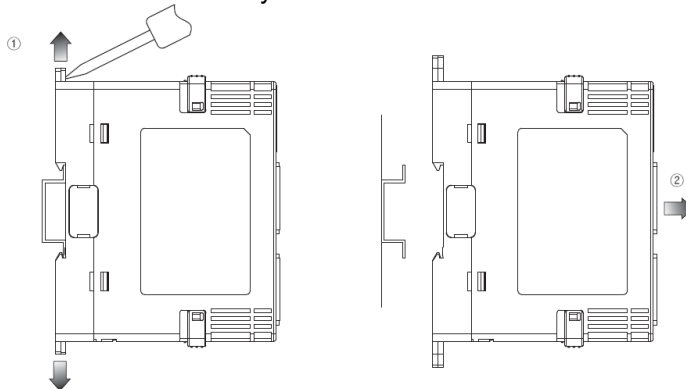

# 4 Connections and Insulation Block Diagram

## 4.1 TM2 Series

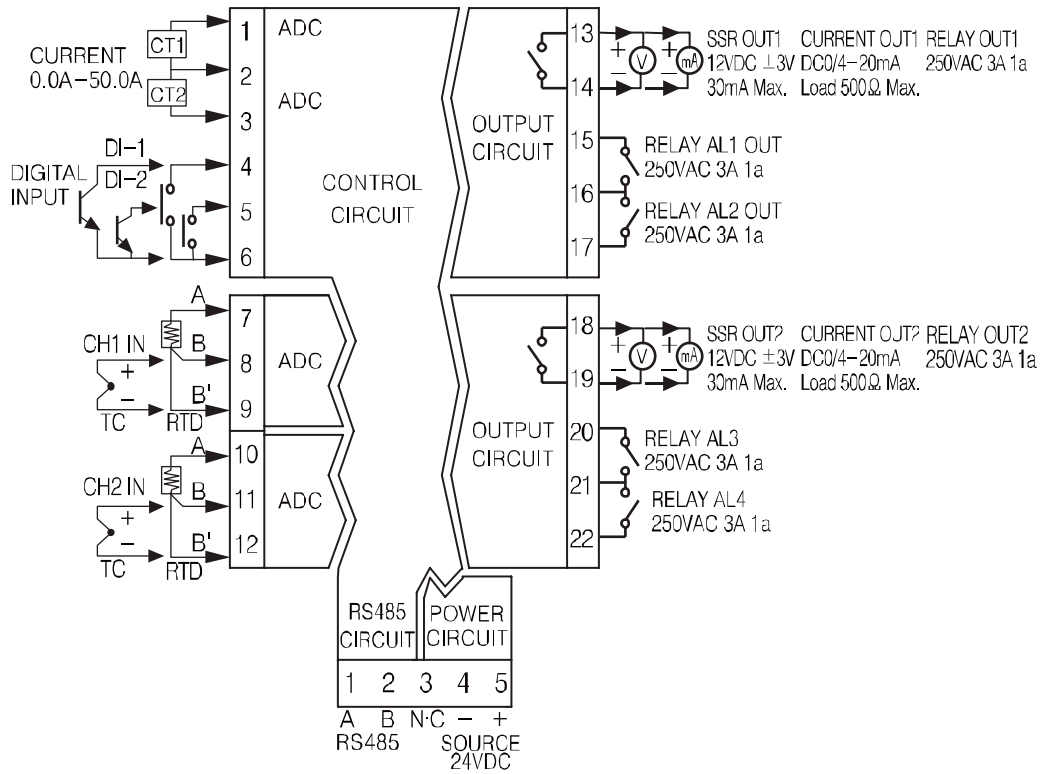

※ Relay AL3/AL4 OUT are available only for TM2-42□□ models.

- Power/Comm. connection terminal [Only for basic module: TM□-□□□B]

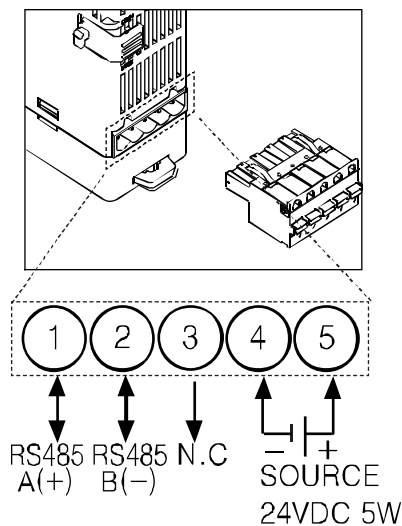

### 4.2 TM4 Series

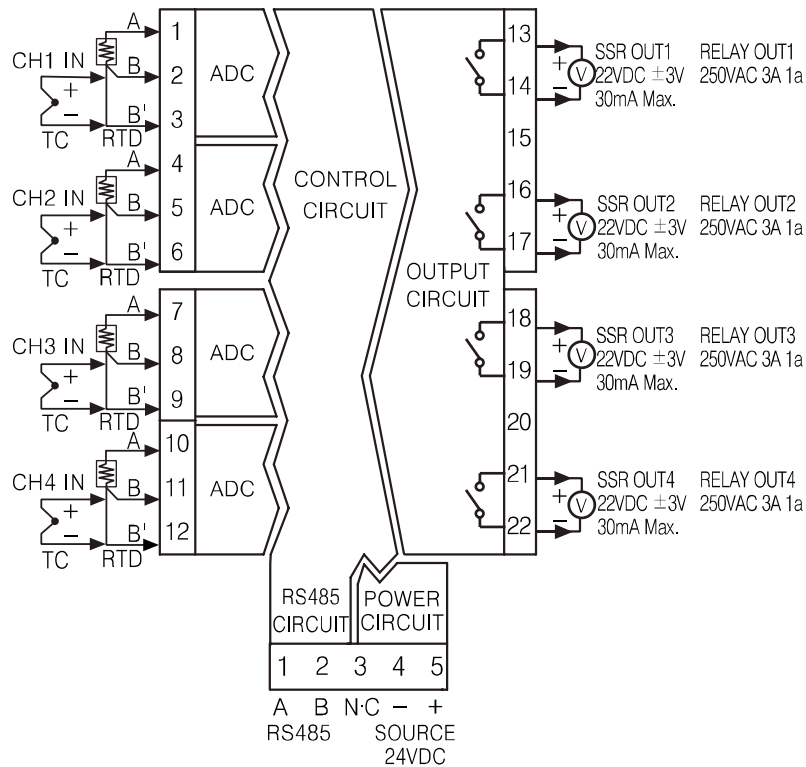

- Power/Comm. connection terminal [Only for basic module: TM□-□□□B]

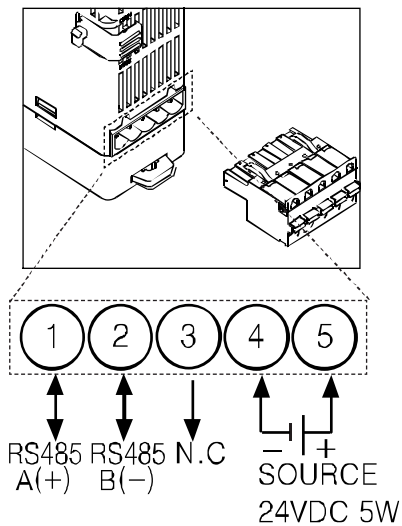

**Note**

- Pay attention to the connection direction when wiring the power supply/communications connection terminal.
- It is recommended to use lines with AWG28 to 14 when connecting the sensor or compensation wire.
- It is recommended to use lines thicker than AWG24 for SSR drive output.
- It is recommended to use lines with AWG26 to 12 for relay output.

### 4.3 Wiring precautions

- Mixing up the input terminals with output terminals and vice versa can lead to product damage.
- Use only sensors supported by the product.
- Make sure to connect rated SSRs or loads to the output terminals.
- Make sure to connect the communication cable with correct communication terminals (A, B).
- Make sure to observe correct polarity of power source terminals. (+ and -).
- Use crimp terminals of size specified below.

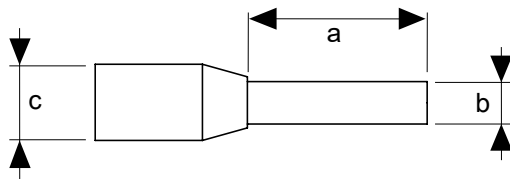

Terminal number	a	b	c
1 to 12	10mm	Max. 1.7mm	Max. 3.7mm
13 to 22	10mm	Max. 2.1mm	Max. 4.2mm

#### 4.3.1 Sensor connection

##### (1) Compensation wire connection

For thermocouple sensors, use compensation wire of the same specification as input sensors. Using an extension wire of different specification and/or material will increase inaccuracy of temperature sensing. It is recommended to choose high performance compensation wire for more reliable sensing.

##### (2) Measurement error

- Do not mix up the direction of the input sensor connector.
- Carefully adjust both load and sensor positions.
- Make sure the sensor is securely attached to the input connector.

##### (3) Wiring with AC power lines

Do not put the sensor lines in close proximity of the AC power lines.



#### Note

- Make sure the sensor is completely inserted in the connector using a crimped terminal.
- Fix the sensor to the connector properly for accurate measurement.

### 4.3.2 Power supply connection

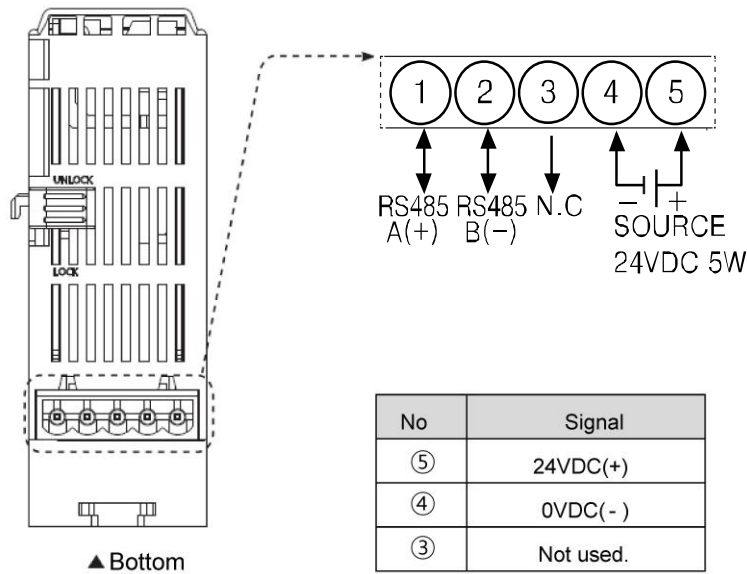

#### Note

- Use power line with AWG26 to 12.
- Calculate the total power consumption first and then connect a power supply system of appropriate capacity.

### 4.3.3 Communication line wiring

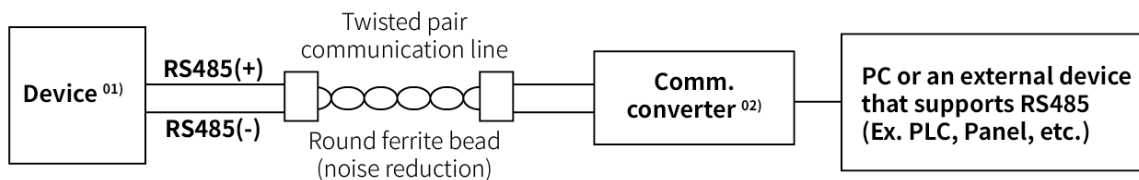

01) Connect to a PC using a communication converter(SCM-US, sold separately) on the PC loader port.

02) Communication Converters: SCM-38I / SCM-US48I (sold separately)



#### Note

- Do not tie the communications line together with the AC power line.
- Use twisted pair cables for the communications line only.
- Do not allow the communication line to exceed 800m in length.
- For further details, please refer to '6.5 Communications'.

### 4.3.4 Module connection

#### (1) Basic module positioning

The basic module can be mounted anywhere in the connected group. It works regardless of communication address.

Basic module

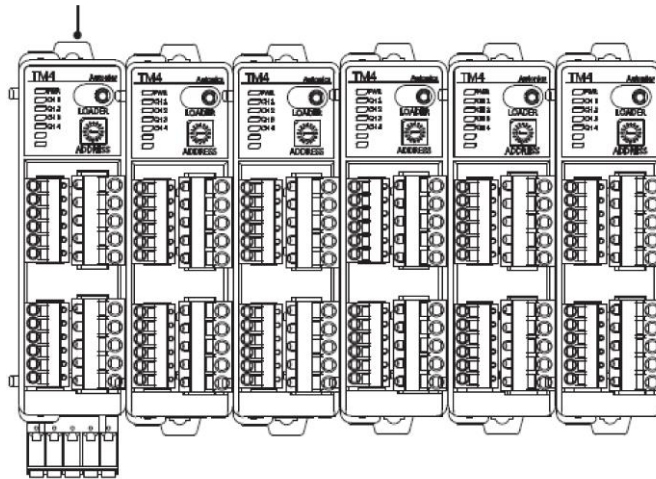

Basic module

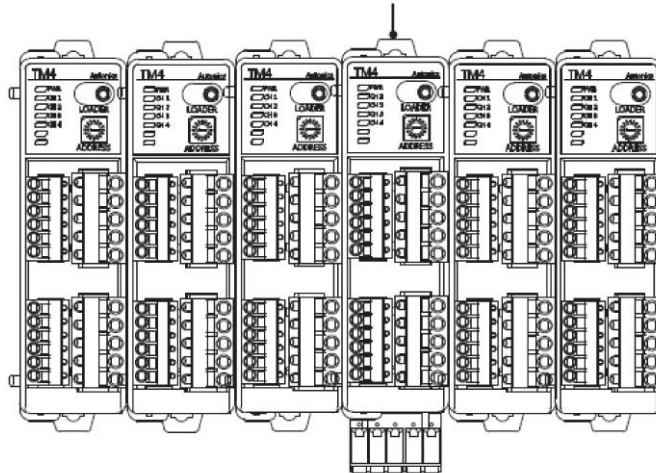

**(2) Module Expansion**

When using the bottom power supply/communication connection terminal (Power/Comm. connection terminal), up to 31 modules can be connected at the same time.  
 Maximum required power = 31 X 5 W = 155 W

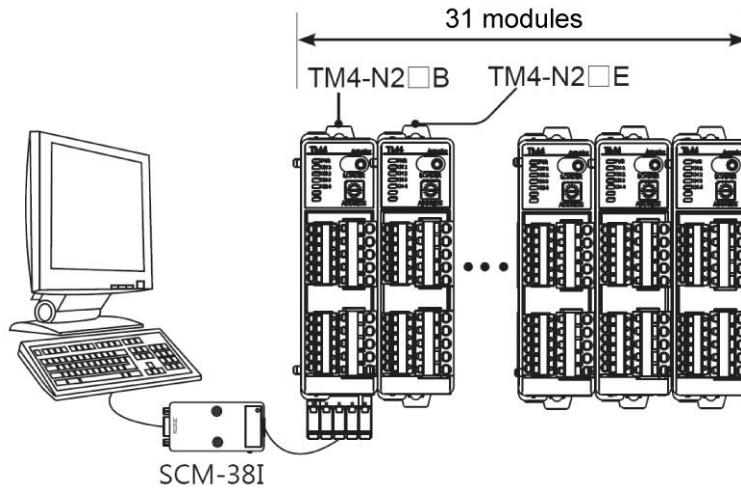

When connecting several module sets (31 modules or less), each module set requires separate power supply.

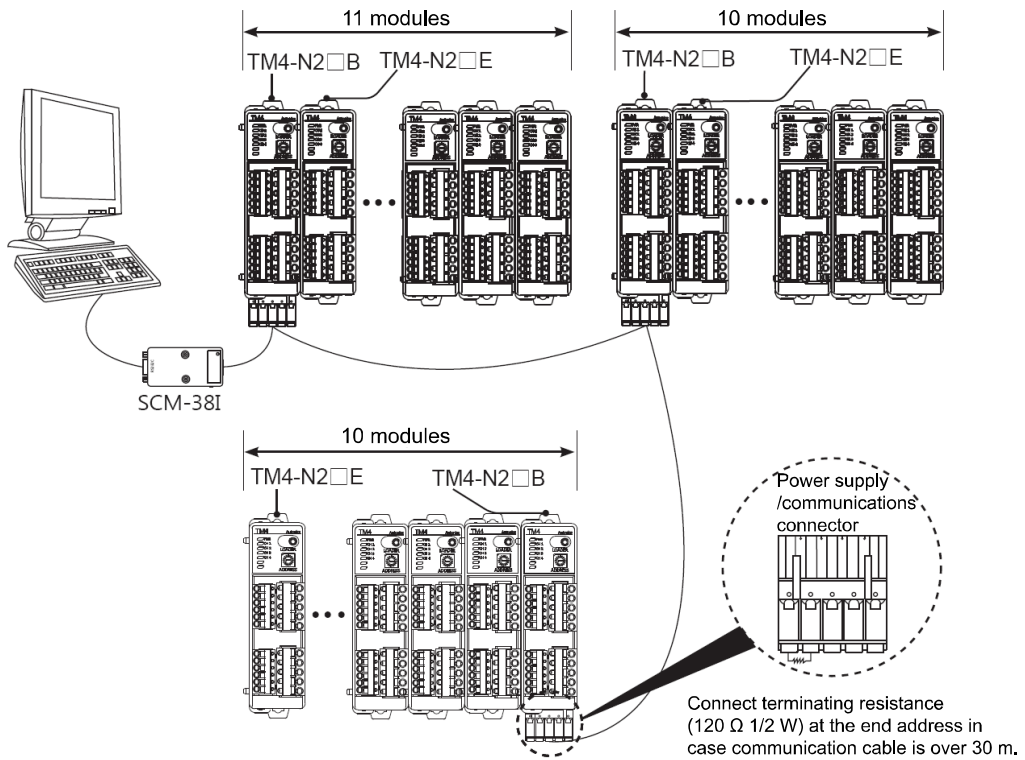

## 5 Preparation and Startup

### 5.1 General process

Before operating TM Series for the first time, do the following:

- 1st Connect all external devices, sensor and load to the TM Series.
- 2nd Set parameter values through external connecting devices (PC loader program, GP etc.).
- 3rd Download the parameters to TM Series.
- 4th Proceed with auto-tuning or set control variables, and then start control.



#### Note

For using comprehensive device management program 'DAQMaster, parameters are automatically downloaded at the time when they are changed.

### 5.2 Setup values when power ON

Setting category	Factory default	Previous setting value	Power ON setting value
Auto/Manual	Auto	Auto	Auto
		Manual	Manual
RUN/STOP	RUN	RUN	RUN
		STOP	STOP
PID/ONOFF	PID	PID	Maintains preset value
		ONOFF	Maintains preset value
MV	0.0	Preset MV	Maintains preset value
	0.0	Stop MV	Maintains preset value
	0.0	Sensor Error MV	Maintains preset value

## 5.3 Temperature control examples

### 5.3.1 Single module

#### (1) TM4-N2RB model (relay output)

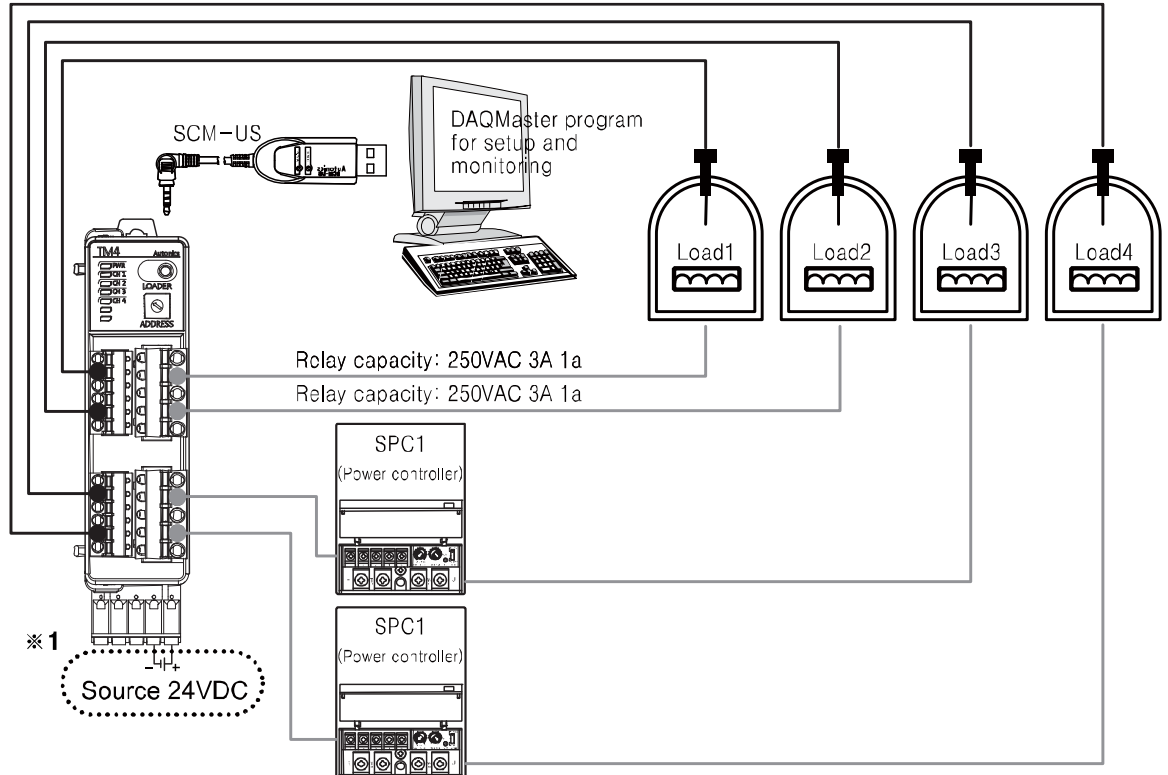

※1. Using SCM-US enables only setting parameter. To monitor and control temperature requires the additional 24VDC power supply.



#### Caution

Do not connect SCM-US and RS485 communications cables at the bottom at the same time.

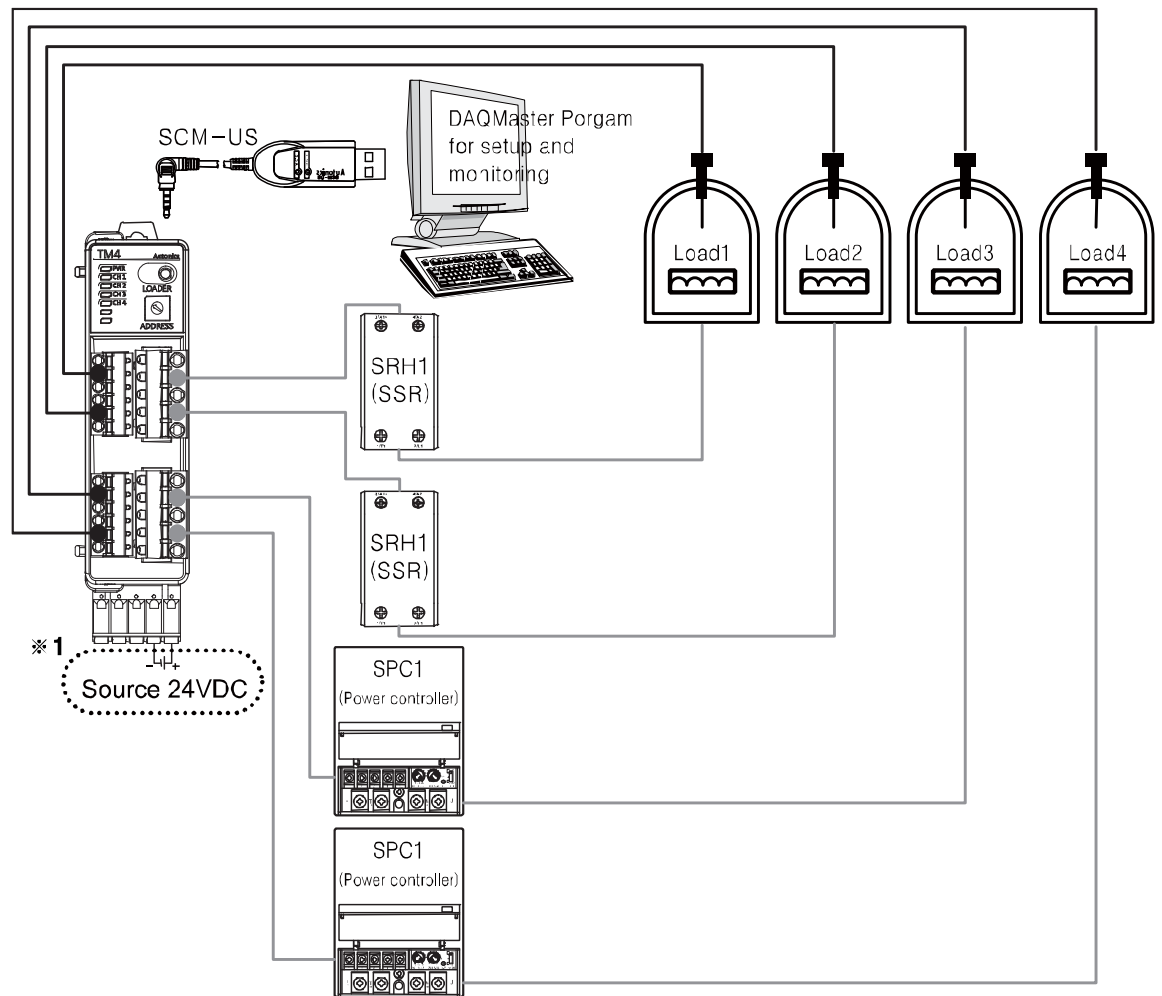
**(2) TM4-N2SB model (SSR drive output)**

- ※1. Using SCM-US enables only setting parameter. To monitor and control temperature requires the additional 24VDC power supply.

**⚠ Caution**

- Do not connect SCM-US and RS485 communications cables at the bottom at the same time.
- Use an isolated type SSR.

### 5.3.2 Multiple modules

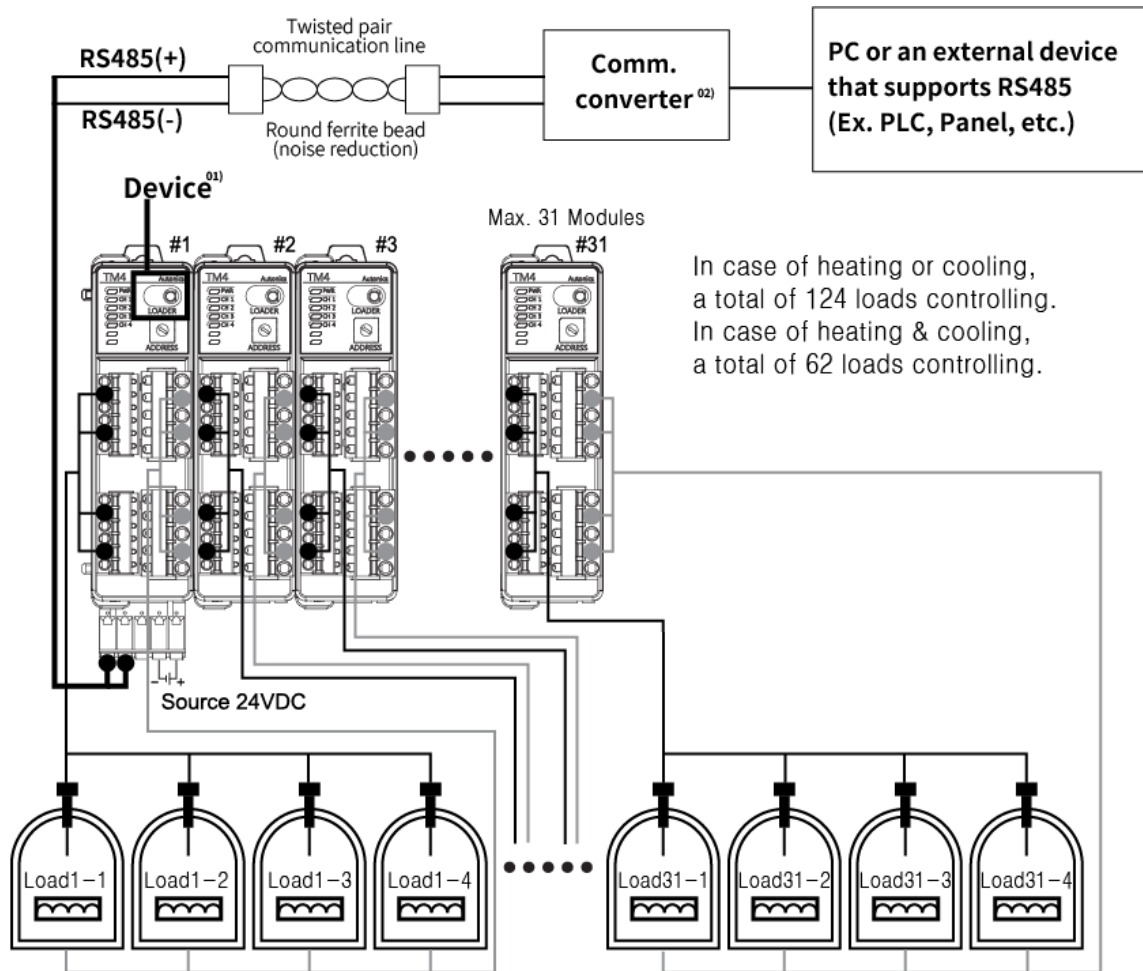

01) Connect to a PC using a communication converter(SCM-US, sold separately) on the PC loader port.

02) Communication Converters: SCM-38I / SCM-US48I (sold separately)

## 6 Parameter Settings and Functions

### 6.1 Input

#### 6.1.1 Input type and temperature range

Input type		Decimal point	Display method	Using range (°C)	Using range (°F)
Thermo-couple	K (CA)	1	K (CA) .H	-200 to 1,350	-328 to 2,462
		0.1	K (CA) .L	-200.0 to 1,350.0	-328.0 to 2462.0
	J (IC)	1	J (IC) .H	-200 to 800	-328 to 1,472
		0.1	J (IC) .L	-200.0 to 800.0	-328.0 to 1472.0
	E (CR)	1	E (CR) .H	-200 to 800	-328 to 1,472
		0.1	E (CR) .L	-200.0 to 800.0	-328.0 to 1,472.0
	T (CC)	1	T (CC) .H	-200 to 400	-328 to 752
		0.1	T (CC) .L	-200.0 to 400.0	-328.0 to 752.0
	B (PR)	1	B (PR)	0 to 1,800	32 to 3,272
	R (PR)	1	R (PR)	0 to 1,750	32 to 3,182
	S (PR)	1	S (PR)	0 to 1,750	32 to 3,182
	N (NN)	1	N (NN)	-200 to 1,300	-328 to 2,372
	C (TT) <sup>01)</sup>	1	C (TT)	0 to 2,300	32 to 4,172
	G (TT) <sup>02)</sup>	1	G (TT)	0 to 2,300	32 to 4,172
	L (IC)	1	L (IC) .H	-200 to 900	-328 to 1,652
		0.1	L (IC) .L	-200.0 to 900.0	-328.0 to 1,652.0
U (CC)	1	U (CC) .H	-200 to 400	-328 to 752	
	0.1	U (CC) .L	-200.0 to 400.0	-328.0 to 752.0	
Platine II	1	PLII	0 to 1,400	32 to 2,552	
RTD	JPt100 Ω	1	JPt100.H	-200 to 600	-328 to 1,112
		0.1	JPt100.L	-200.0 to 600.0	-328.0 to 1,112.0
	DPt100 Ω	1	DPt100.H	-200 to 600	-328 to 1,112
		0.1	DPt100.L	-200.0 to 600.0	-328.0 to 1,112.0
	DPt50 Ω	0.1	DPt50.L	-200.0 to 600.0	-328.0 to 1,112.0
	Cu50 Ω	0.1	CU 50	-200.0 to 200.0	-328.0 to 392.0
	Cu100 Ω	0.1	CU 100	-200.0 to 200.0	-328.0 to 392.0
Nickel120 Ω	1	NI12	-80 to 260	-112 to 500	

※1. C(TT): Same as existing W5(TT) type temperature sensor.

※2. G(TT) : Same as existing W(TT) type temperature sensor.

- Temperature sensors convert subject temperature to electrical signals for the temperature controller, allowing it to control output.
- SV (setting value) can only be set within the input range.

### 6.1.2 Input type

This product supports multiple input types, making it possible for the user to choose from thermocouples, resistors, and analog voltage/current. Different sensors can be designated to each channel.



Ex.

CH1 input type = KCA.H, CH2 input type = JIC.H

Setting group	Parameter	Setting range	Factory default	Unit
Initial Setting	Input Type	Refer to 6.1.1 Input type and temperature range	K(CA).H	-



Note

- When changing input type settings, the high-limit and low-limit values of SV are automatically changed to max/min values of operational temperature range of the modified input type. You must reset these values. (SV, Multi SV No, SV-0 to SV-3 and input correction are initialized.) However, measurement units remain the same.
- If the measured value is out of the input range, external device displays HHHH (high-limit), LLLL (low-limit) and displays OPEN when the sensor is not connected.

### 6.1.3 Input temperature sensor unit

When selecting the temperature sensor input options, you can set the desired units of operation temperature/display temperature.

Setting group	Parameter	Setting range	Factory default	Unit
Initial Setting	Unit	°C, °F	°C	-



Note

When modifying the temperature units, setting values of the related parameters remain the same as the existing values, and SV, Multi SV No., SV-0 to SV-3, SV high-limit/low-limit, and input correction will be initialized.

### 6.1.4 Input correction

This feature is used to compensate for input correction produced by thermocouples, RTDs, or analog input devices, but NOT by the controller itself.

The input correction adjustments function is mainly used when the sensor cannot be attached directly to control object. It is also used to compensate for temperature variance between the sensor's installation point and the actual measuring point.

Setting group	Parameter	Setting range	Factory default	Unit
Initial Setting	Input Bias	-999 to 999 (H) -999.9 to 999.9 (L)	0	Digit



Ex.

If the controller displays 78°C when the actual temperature is 80°C, set the input correction to 2 in order to adjust the controller's display temperature to 80°C.



Note

- Make sure that an accurate temperature variance measurement is taken before setting values of Input Correction. An inaccurate initial measurement can lead to greater variance.
- Many of today's temperature sensors are graded by their sensitivity. Since higher accuracy usually comes at a higher cost, most people tend to choose sensors with medium sensitivity. Measuring each sensor's sensitivity correction and using the Input Correction feature for correction can ensure higher accuracy in temperature reading.

### 6.1.5 Input digital filter

It is not possible to perform high accuracy control if the PV (present value) fluctuates because of noise elements, disturbance, or instabilities in the input signal. Using the Input Digital Filter function can stabilize PV to realize more reliable control.

Setting group	Parameter	Setting range	Factory default	Unit
Initial Setting	Digital Filter	0.1 to 120.0	0.1	Sec.



Ex.

When the Input Digital Filter is set to 0.4 seconds, the digital filter is applied according to a sampling value collected over 0.4 seconds (400ms).



Note

When the Input Digital Filter is used, PV (present value) can vary from the actual input value.

### 6.1.6 SV high/low-limit value

You can limit the SV (setting value) range within the temperature range of the sensor or analog input type (refer to 6.1.1 Input type and temperature range) in order to prevent the system from controlling with improper SV.

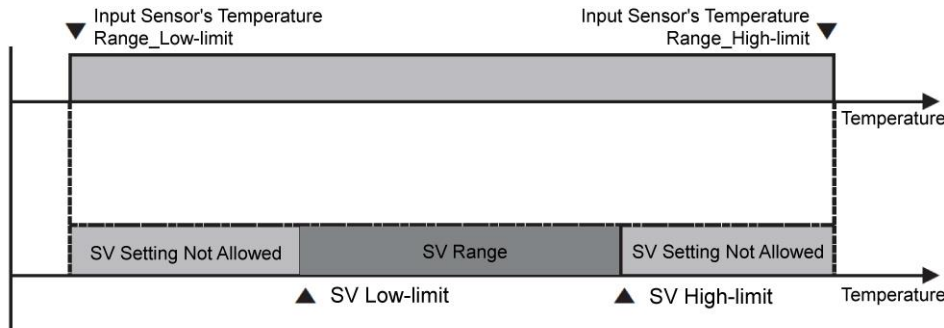

Setting group	Parameter	Setting range	Factory default	Unit
Initial Setting	SV High-limit	Refer to the below.	1350	°C/°F
	SV Low-limit		-200	

- SV low-limit value: Min. value of input sensor range to SV high-limit - 1 digit
- SV high-limit value: SV low-limit + 1 digit to max. value of input sensor range



#### Note

- Attempts to set the limits outside the min/max input range, or analog's high/low-limits, are not accepted. Instead, the previous settings are retained.
- SV (setting value) can only be set within the SV low-limit and SV high-limit.
- SV low-limit cannot exceed SV high-limit.
- Changing the input sensors automatically changes the SV high/low-limit settings to max/min values of the changed input sensor input. The user is required to reset related settings.

## 6.2 Control output

### 6.2.1 Control output operation mode

Control output modes for general temperature control include heating, cooling, and heating and cooling.

Heating control and cooling control are mutually opposing operations with inverse outputs.

The PID time constant varies based on the controlled objects during PID control.

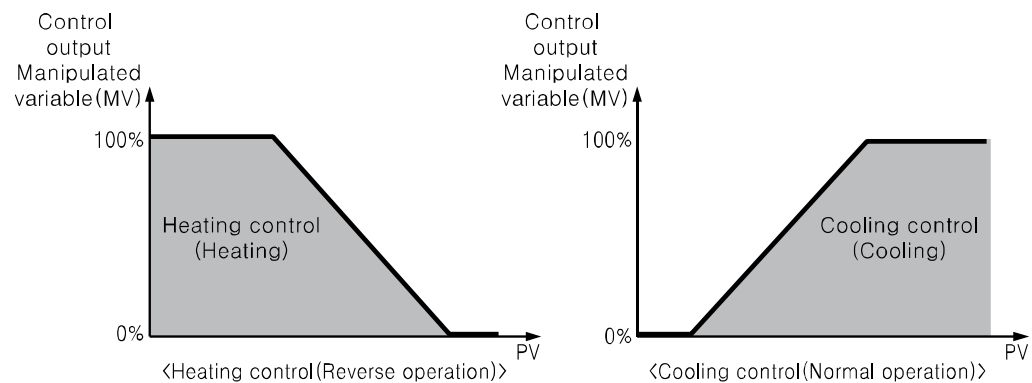

Setting group	Parameter	Setting range	Factory default	Unit
Initial Setting	Operating Type	HEATING, COOLING HEATING & COOLING	HEATING	-

#### (1) Heating control

Heating control mode: the output will be provided in order to supply power to the load (heater) if PV (present value) falls below SV (setting value).

#### (2) Cooling control

Cooling control mode: the output will be provided in order to supply power to the load (cooler) if PV (present value) rises above SV (setting value).

### (3) Heating and cooling control

Heating and cooling control mode: heating and cooling with a single temperature controller when it is difficult to control subject temperature with only heating or cooling.

Heating and cooling control mode controls the object using different PID time constants for each heating and cooling. It is also possible to set heating and cooling control in both PID control or ON/OFF control mode. Heating/cooling output can be selected among Relay output, SSR drive voltage output and current output depending on model types chosen according to your application environment. (Note that only standard SSR control is available for SSR drive output in OUT2.)

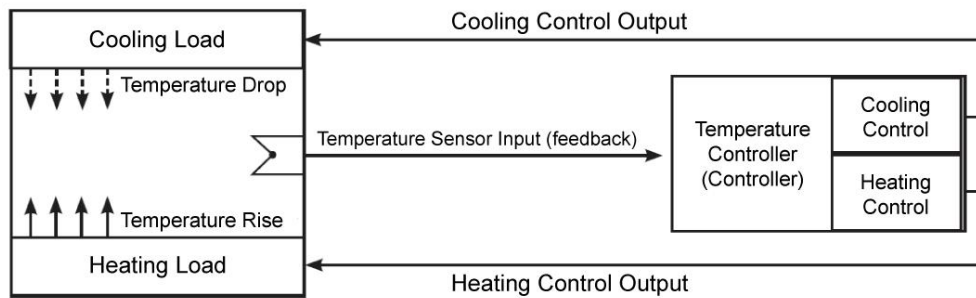

- For heating/cooling control, each output for heating and cooling is automatically allocated as described in the following table.

Series	Heating control	Cooling control	Remarks
TM4	CH1 OUT	CH2 OUT	Heating output: Selectable control output by model
	CH3 OUT	CH4 OUT	Cooling output: Selectable control output by model
TM2	CH1 OUT	AL1 OUT	Heating output: Selectable control output by model
	CH2 OUT	AL2 OUT	Cooling output: Relay output fixed



#### Note

For TM2 Series, heating output can be selected by models from relay output, SSR drive output and current output. Cooling output is fixed to relay output.

## 6.2.2 Dead band/Overlap band

In heating and cooling control, it is possible to designate a dead band between heating and cooling control bands based on SV (setting value).

- A dead band forms around the SV when DB is set to a positive value. No control occurs in the dead band area. Therefore, heating and cooling MVs become 0.0% in the formed dead band.
- An overlap band (simultaneous application of heating and cooling MVs) forms around the SV when DB is set to a negative value.

Setting group	Parameter	Setting range	Factory default	Unit
Control Operation	Dead_Overlap band	[Temp. H] -999 to 999	0	°C/°F
		[Temp. L] -9999 to 9999 (-999.9 to 999.9)		

- Set dead band to 0 when a dead band or an overlap band is not used.



### Note

- Input sensor (H, L) setting determines the use of a decimal point.

**(1) Using Dead band**

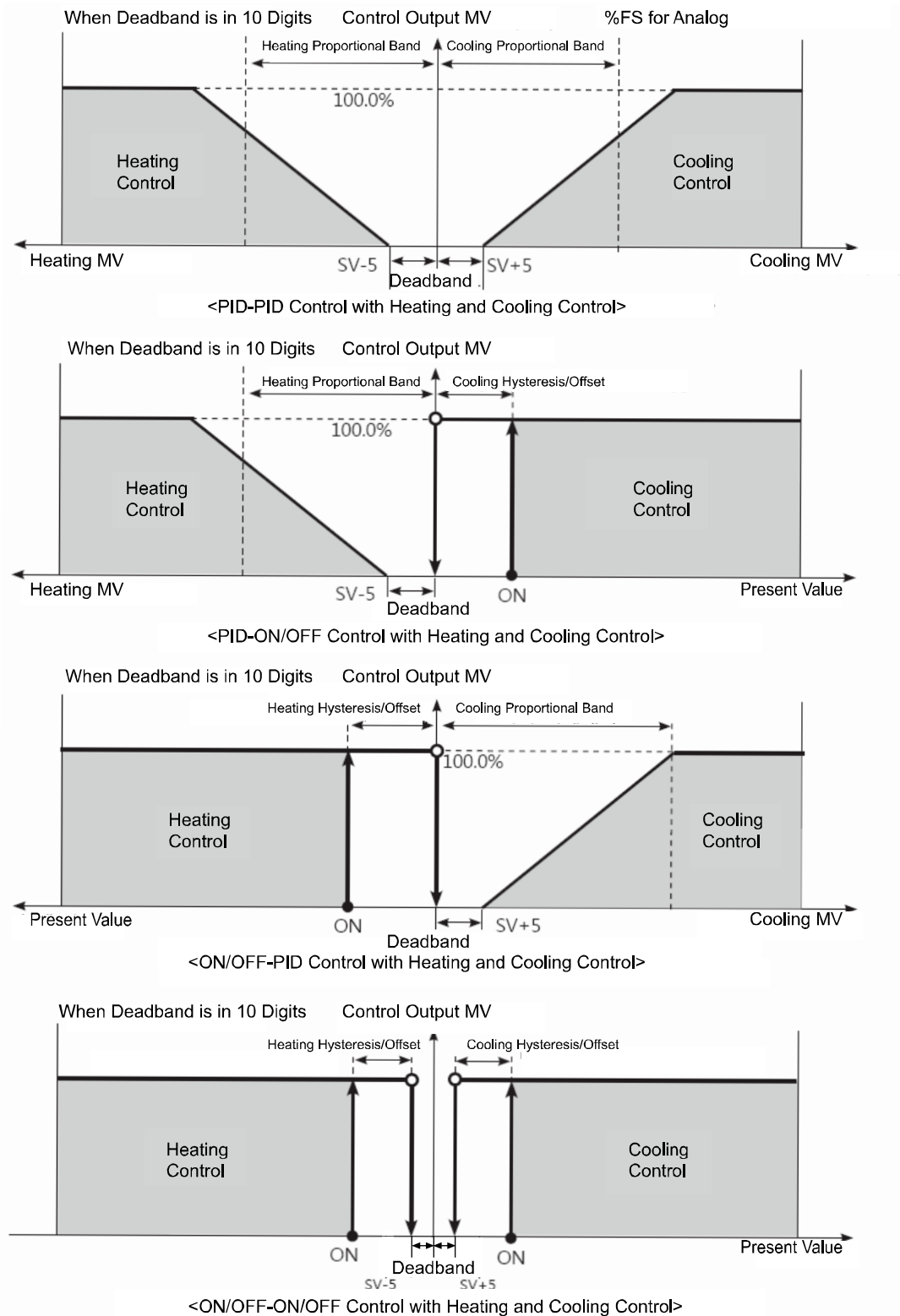

**(2) Using Overlap band**

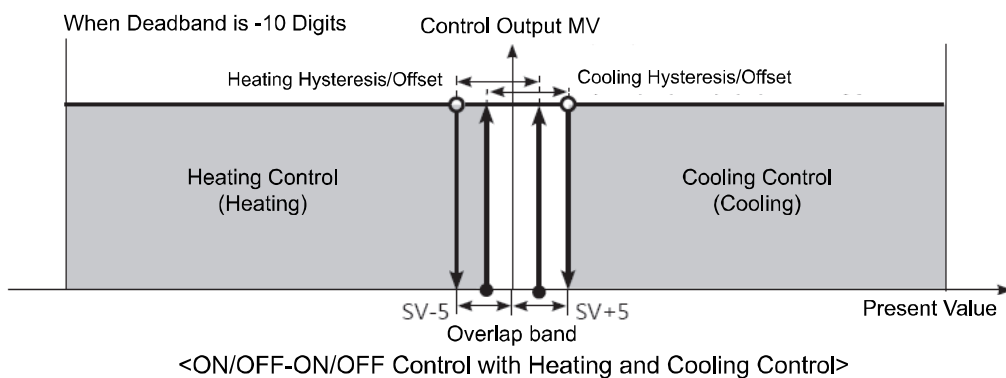
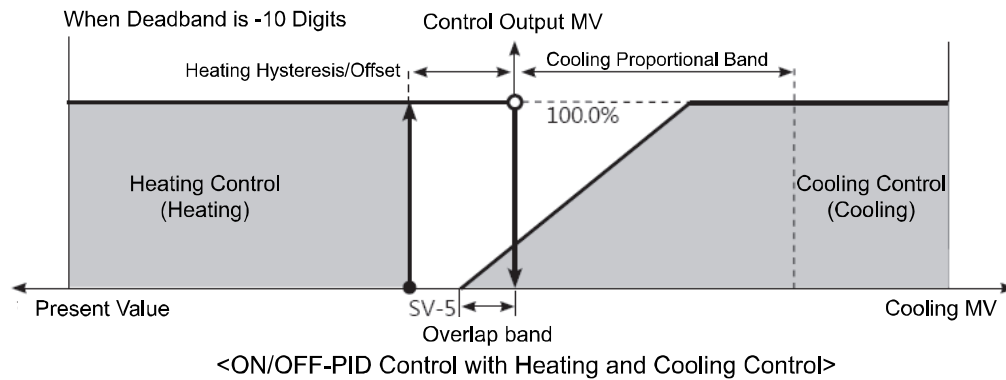
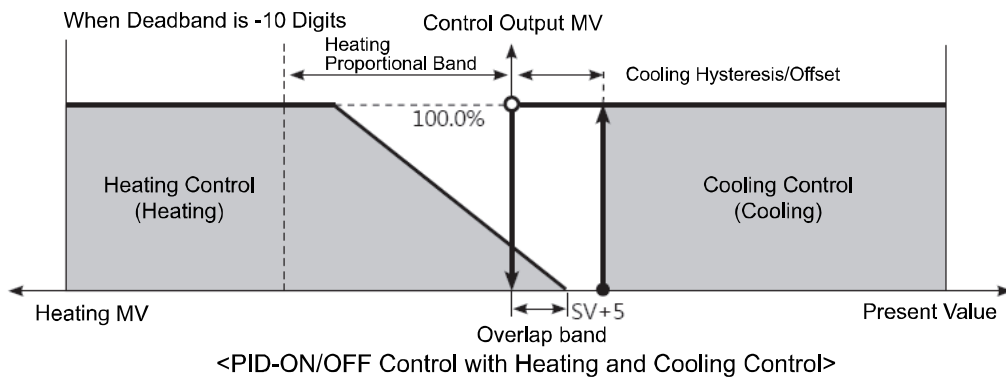
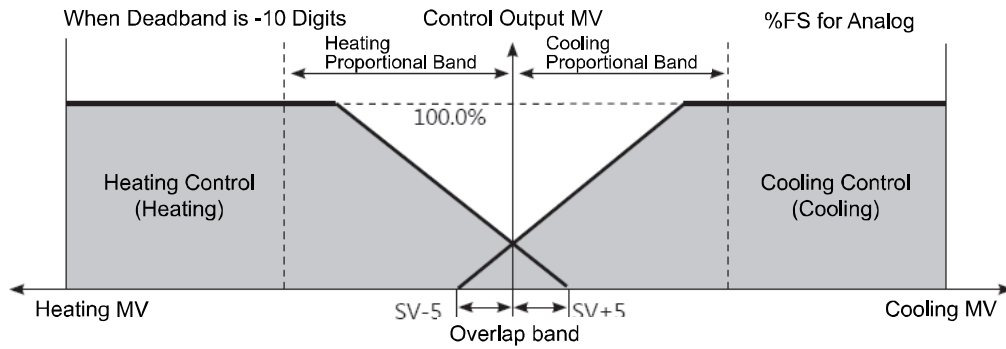

**(3) Using neither Dead band nor Overlap Band**

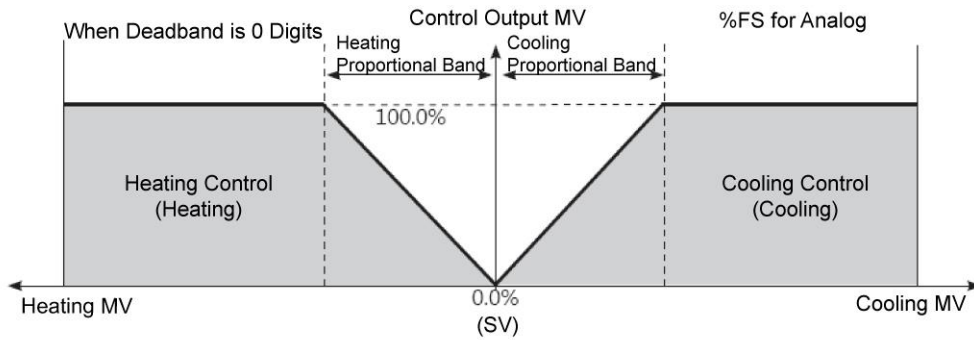

<PID-PID Control with Heating and Cooling Control>

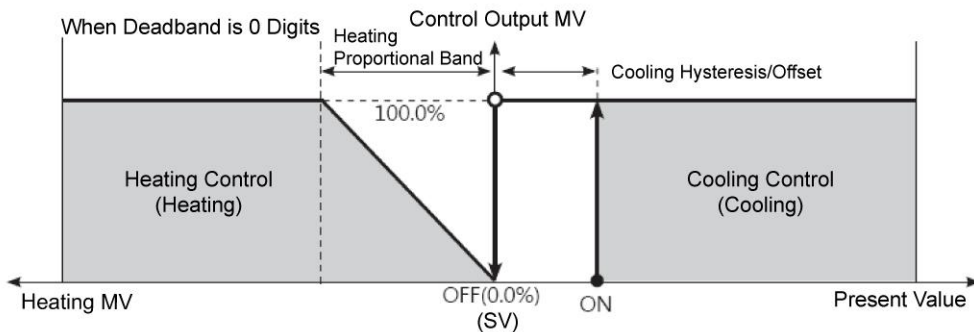

<PID-ON/OFF Control with Heating and Cooling Control>

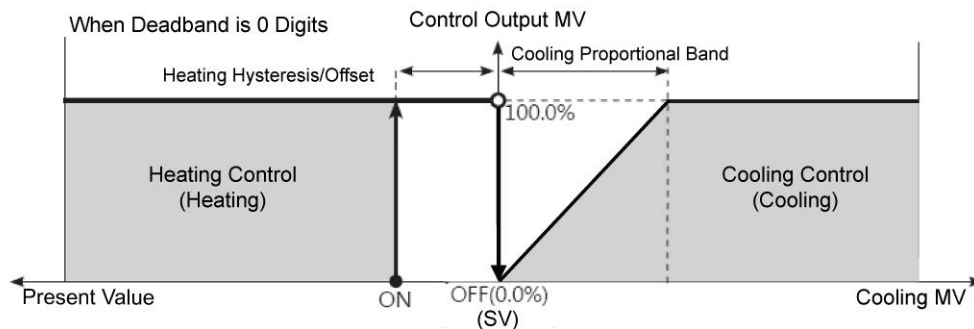

<ON/OFF-PID Control with Heating and Cooling Control>

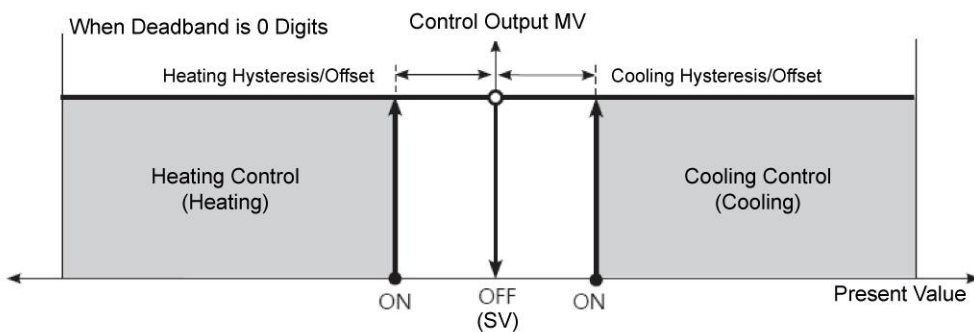

<ON/OFF-ON/OFF Control with Heating and Cooling Control>

### 6.2.3 MV high/low-limit value

MV high/low-limit values for control output can be configured to the actual MV, provided the temperature controller's MV calculation exceeds the limits.

During heating and cooling control, cooling MV carries a "-" prefix. Therefore, the high-limit is expressed as a + value on the heating side and the lower limit as a - value on the cooling side.

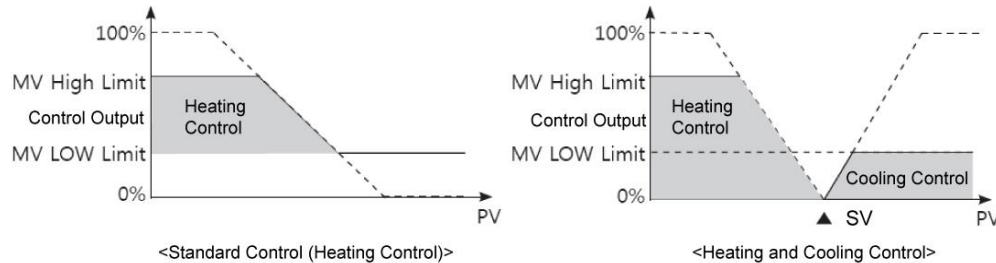

Setting group	Preceding condition	Parameter	Setting range	Factory default	Unit
Control Operation	Heating Cooling	MV Low-limit	0.0 to MV high-limit - 0.1	0.0	%
		MV High-limit	MV low-limit + 0.1 to 100.0	100.0	
	Heating and Cooling	MV Low-limit	-100.0 to 0.0	-100.0	%
		MV High-limit	0.0 to 100.0	100.0	



#### Note

- Same MV high/low-limit value will be applied during Auto-tuning.
- MV high/low-limit values are not applied to manual control, MV upon control stop, MV upon a sensor error, and initial manual control MV.
- MV high/low-limit value configuration is not available for ON/OFF control in standard control mode (heating or cooling control).

## 6.2.4 Ramp function

Ramp is a feature used to configure the changed temperature per unit time toward SV (setting value). The feature limits change rate of SV and thereby restricts sudden temperature changes (increase and decrease) in the control subject.

Ramp is commonly used in applications where rapid temperature changes (increase and decrease) could impact negatively on the control subject.

SV determines the control of the control subject temperature. The SV changes based on the configured changed temperature per unit time (hereinafter referred to as RAMP SV).

Ramp Up change rate and Ramp Down change rate can be set independently.

Setting group	Parameter	Setting range	Factory default	Unit
Control Operation	Ramp_Up/Down Change Rate	0 (OFF) to 9999	0	°C/°F/ Digit
	Ramp Time Unit	SEC, MIN, HOUR	MIN	-



### Note

- For ceramic or pottery furnaces, rapid heating may break the furnace subject. Apply Ramp Up Change Rate to control the temperature.
- Activating the ramp feature when the ramp is not in operation limits the rate of SV (setting value) change based on PV (present value). Changing SV or ramp parameters when the ramp is in operation limits the rate of SV change based on SV at the point of the change.
- Alarm activation with the ramp in operation depends on the final SV.
- Setting the rate of ramp change to 0 deactivates the ramp feature.

### (1) Ramp status by modes

Operation status	RAMP rate	Ramp function
All modes.	When 0	Inactive
OPEN, HHHH, LLLL, Auto-tuning, Auto→Manual, RUN→STOP	Irrespective of conditions.	Inactive
OPEN, HHHH, LLLL, after Auto-tuning, PV = SV	Irrespective of conditions.	Inactive
Power On, SV change, switch from STOP to RUN, switch from Manual to Auto, Ramp Rate or Ramp time unit change	When not 0	Active



Ex.

Example Ramp graph

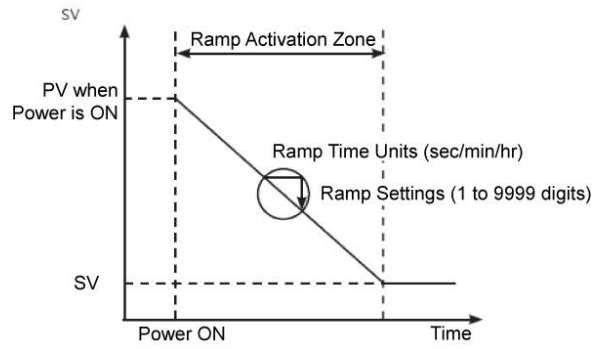
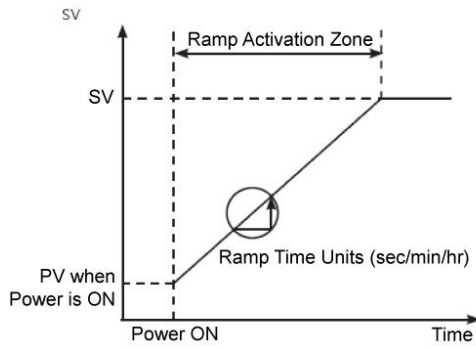

<Initial power on, Ramp value change>

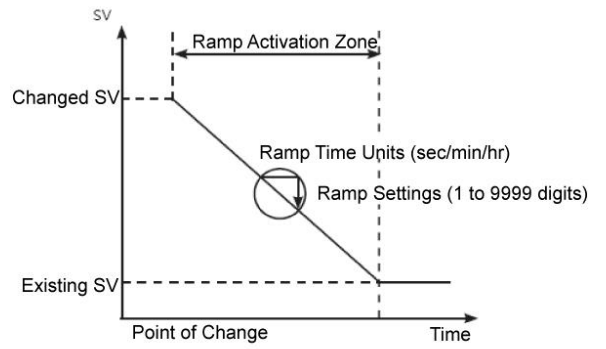
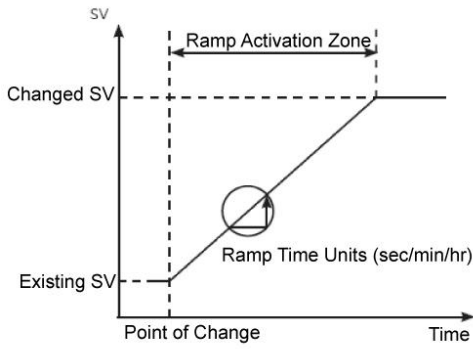

<SV setting change, Change SV setting with multi SV feature>

### 6.2.5 Auto/Manual control

- Auto control: This mode implements control over MV, which is calculated under PID control and based on SV as the target.
- Manual control: This mode implements control with user-defined MV.

Setting group	Parameter	Setting range	Factory default	Unit
Monitoring	Auto-Manual Control	AUTO, MANUAL	AUTO	-

- Can be used by setting digital input terminal (DI1, DI2) to STOP function.



#### Note

- Auto/manual control switching is not allowed in ON/OFF control mode.
- When the unit is powered on following a power interruption or shutdown, auto or manual control will be maintained.
- When in operation, AT (Auto-tuning) can be switched to manual control.
- When in Stop mode, manual control can be activated.
- If SBA (Sensor Break Alarm) occurs during standard control, the sensor error MV is applied. In this state, switching to manual mode is possible and manual control MV settings can also be modified.
- When the control unit is in operation, it is possible to switch to manual or auto control mode.
- Priority: Manual control > Stop > Open (sensor break)

### 6.2.6 Manual control baseline MV

When switching from auto to manual control you can set the initial MV.

- AUTO-MV: When switching modes use auto control MV as the initial manual control.
- PRESET-MV: Apply preset MV as the initial manual control.

Setting group	Preceding condition	Parameter	Setting range	Factory default	Unit
Control Setting	PID	Initial Manual MV	AUTO-MV: PRESET-MV:	AUTO-MV:	-

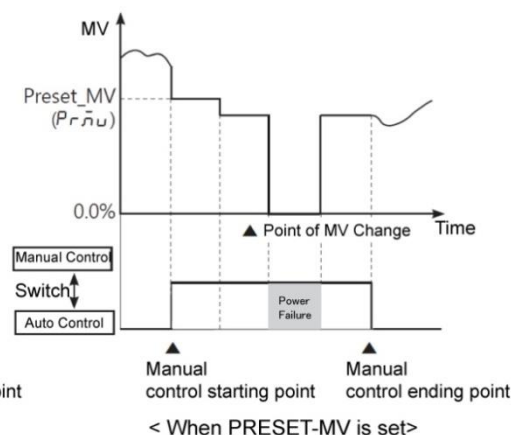
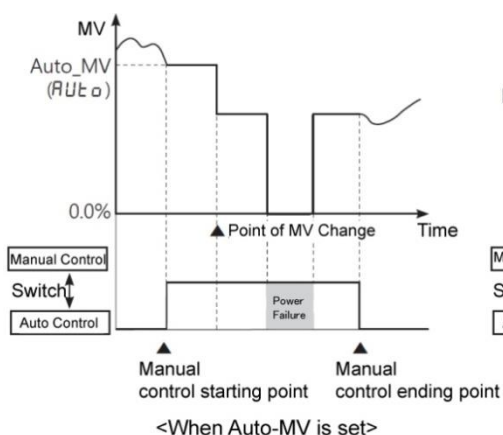

#### Note

Reverting to power, the control starts with the MV of the power off.

## 6.2.7 Manual control initial MV

If the baseline MV for manual control is configured to PRESET-MV, you can set the initial MV for manual control.

Setting group	Preceding condition	Parameter	Setting range	Factory default	Unit
Control Setting	Heating, Cooling, PID	Preset Manual MV	0.0 to 100.0	0.0	%
	Heating & Cooling, PID		-100.0 (Cool) to 100.0 (Heat)	0.0	



### Note

When in heating and cooling control, a setting between 0.1 and 100.0 applies heating MV, and a setting between 0.1 and -100.0 applies cooling MV.

## 6.2.8 Control output

If the control output type is a current or SSR drive output model, control output is supported at the same time, so the user can choose a suitable output type.

Setting group	Parameter	Setting range	Factory default	Unit
Initial Setting	Output(SSR_Curr) Type	SSR, CURRENT	CURRENT	-



### Note

The relevant parameter will be activated only if the model is TM2-□□C□ (current or SSR drive output type).

### 6.2.8.1 Current output range

If the control output is set to current output, you can select high and low-limit range for the current output as either 4-20mA or 0-20mA.

Setting group	Parameter	Setting range	Factory default	Unit
Initial Setting	Current Output Range	0-20, 4-20	4-20	mA



### Note

If the model is TM2-□□C□ (current or SSR drive output type), the relevant parameter will be activated only if the control output is set to current.

## 6.3 Temperature control

### 6.3.1 Temperature control method

You can choose the type of temperature control method.

Setting group	Preceding condition	Parameter	Setting range	Factory default	Unit
Initial Setting	Heating, Cooling	Control Method	PID, ONOFF	PID	-
	Heating and Cooling		PID-PID PID-ONOFF ONOFF-PID ONOFF-ONOFF	PID-PID	-

### 6.3.2 ON/OFF control

Controls the temperature by comparing PV(present value) with SV(setting value) and turning power to the load on or off.

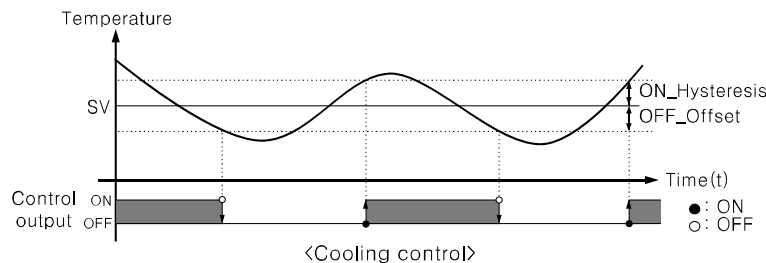
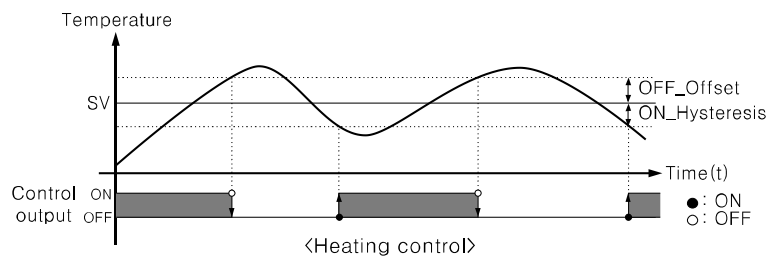

#### 6.3.2.1 Hysteresis

An ON/OFF control feature is used to define the control output ON/OFF points. ON\_Hysteresis sets the output on point and OFF\_Offset sets the off point.

Setting hysteresis too low can result in hunting induced by disturbance (noise, chattering, etc.). To minimize hunting, set ON\_Hysteresis and OFF\_Offset values according to the heater or cooler's capacity and thermal characteristics, control subject and sensor response characteristics, installation conditions, and other defining factors.

Setting group	Preceding condition	Parameter	Setting range	Factory default	Unit	
Control Operation	Heating & Cooling	Heating	Heating_ON Hysteresis	1 to 100(H) 0.1 to 100.0(L)	2	Digit
			Heating_OFF Offset	0 to 100(H) 0.0 to 100.0(L)	0	
		Cooling	Cooling_ON Hysteresis	1 to 100(H) 0.1 to 100.0(L)	2	
			Cooling_OFF Offset	0 to 100(H) 0.0 to 100.0(L)	0	

### 6.3.3 PID control

PID control is a combination of proportional (P), integral (I), and derivative (D) controls and offers superb control over control subjects, even with a delay time.

Proportional control (P) implements smooth, hunting-free control; integral control (I) automatically corrects offsets; and derivative control (D) speeds up the response to disturbance. Through these actions, PID control realizes ideal temperature control.

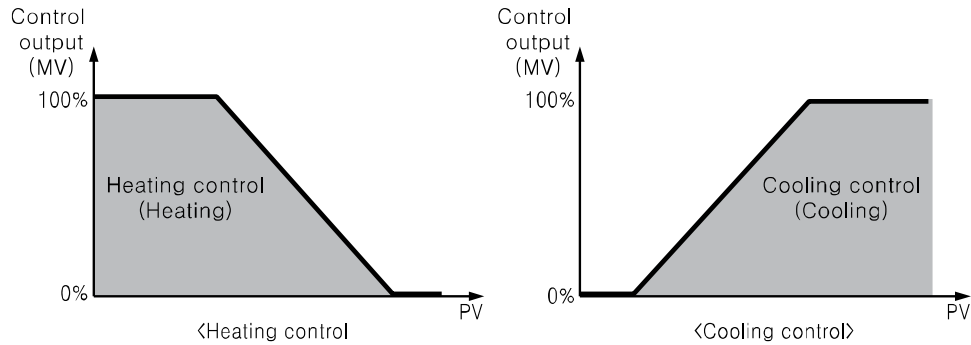

#### Note

How to apply PID control

- Proportional (P) control: Set both integral and derivative times to 0 after PID control is selected.
- Proportional-Integral (PI) control: Set the derivative time to 0 after PID control is selected.
- Proportional-Derivative (PD) control: Set the integral time to 0 after PID control is selected.
- When using the multi-SV function, the same PID time constant will be applied to SV0 to SV3.

#### 6.3.3.1 Proportional band

When PV (present value) is within the proportional band (P), the ON/OFF ratio needs to be adjusted during the proportional period (T). The defined proportional control (time proportional control) section is referred to as the proportional band.

Setting group	Preceding condition	Parameter	Setting range	Factory default	Unit
Control Operation	Heating, PID	Heating_Proportional Band	0.1 to 999.9	10.0	°C/°F
	Cooling, PID	Cooling_Proportional Band			

#### 6.3.3.2 Integral time

MVs from integral and proportional operation become the same when deviation is consistent. The time taken for the two MVs to match is called the integral time.

Setting group	Preceding condition	Parameter	Setting range	Factory default	Unit
Control Operation	Heating, PID	Heating_Integral Time	0 to 9999	0	Sec.
	Cooling, PID	Cooling_Integral Time			



#### Note

- Integral control is not conducted if the integral time is set to 0.
- Setting the integral time too short can intensify Correction Movements and cause hunting.

### 6.3.3.3 Derivative time

In accordance with the deviation of the ramp, the time taken for the MV gained from derivative operation to reach the MV gained from proportional control is called the derivative time.

Setting group	Preceding condition	Parameter	Setting range	Factory default	Unit
Control Operation	Heating, PID	Heating_ Derivation Time	0 to 9999	0	Sec.
	Cooling, PID	Cooling_ Derivation Time			



#### Note

Derivative control is not conducted if the derivative time is set to 0.

### 6.3.3.4 Control period

If relay or SSR is used to send out MV under proportional control, the output is on for a fixed amount of time (within the control period, as a percentage of the MV) and then remains off. The preset period when output ON/OFF takes place is called the proportional control period.

Control using SSR drive voltage output has a faster response than that of relay output. Therefore, by configuring a shorter control period, more responsive temperature control is achieved.

Setting group	Preceding condition	Parameter	Setting range	Factory default	Unit
Initial Setting	Heating, PID	Heating_ Control Time	0.1 to 120.0	20.0 (RY)	Sec.
	Cooling, PID	Cooling_ Control Time		2.0 (SSR)	



#### Note

If using heating and cooling control, configure each control period separately for heating and cooling.

### 6.3.3.5 Offset correction/Manual reset

When only proportional control (P, PD control) is used, the control subject's thermal capacity and heater capacity affect the heating and cooling time. This means stable control will still experience some deviation called offset. Offset can be corrected using manual reset.

Setting group	Preceding condition	Parameter	Setting range	Factory default	Unit
Control Operation	PID	Manual Reset	0.0 to 100.0	50.0	%



#### Note

- Manual reset adjustment based on control results

Under stable control conditions, set the offset to 50% if PV and SV are identical, to over 50.0% if PV is lower than SV, and below 50.0% if PV is higher than SV.

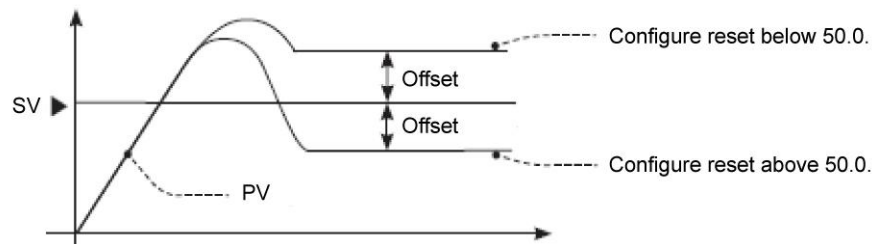

- The offset correction feature can only be used when proportional control is in effect. Setting the integral value to 0 makes the manual reset parameter visible.
- The user cannot configure the manual reset setting during heating and cooling control. Instead, the setting is automatically set to 0% for both heating and cooling.
- Applicable only when integral time is set to 0 (under P control or PD control only).
- Switching from heating and cooling control to standard control (P, PD control) automatically configures the reset setting to 50%.

### 6.3.4 Auto-tuning

In PID control, auto-tuning processes the control subject's thermal characteristics and thermal response rate, and then determines the necessary PID time constant. Application of the PID time constant realizes fast response and high precision temperature control.

#### 6.3.4.1 Auto-tuning ON/OFF

- Auto-tuning automatically stores PID time constants upon termination. These PID time constants can then be modified by the user to suit their usage environment.
- When performing auto-tuning, the output LED of the pertinent channel flashes at 1 second intervals. Once auto-tuning is complete, the output LED automatically goes off, and the parameter value returns from ON to OFF.

Setting group	Preceding condition	Parameter	Setting range	Factory default	Unit
Control Operation	PID	Auto-Tuning Execute	OFF, ON	OFF	-



#### Note

- If manual control is selected during auto-tuning, auto-tuning operation will be closed.
- If sensor break error occurs during auto-tuning, the sensor is automatically closed and the previous PID time constant kept.
- Auto-tuning continues to run even if the temperature reading exceeds or falls below the input range.
- When auto-tuning is in progress, parameters can only be referenced and not altered.
- When auto-tuning is in progress and digital input(DI-1,DI-2) feature is run/stop or auto/manual, auto-tuning will be automatically ended, if concerned DI is inputted or sensor break error occurs.
- Auto-tuning is not available in manual control.

### 6.3.4.2 Auto-tuning mode

Auto-tuning is available in Tun1 MODE (SV) or Tun2 MODE (70% of SV), depending on the baseline value used.

- Tun1 Mode [TUN1]: Auto-tunes and calculates a PID time constant based on SV.
- Tun2 Mode [TUN2]: Auto-tunes and calculates a PID time constant based on 70% of SV.

<TUN1>

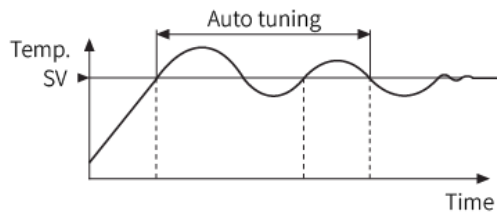

<TUN2>

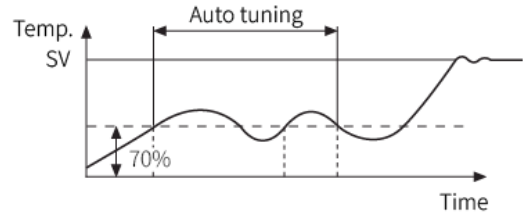

Setting group	Preceding condition	Parameter	Setting range	Factory default	Unit
Initial Setting	PID	Auto-Tuning Mode	TUN1 TUN 2	TUN 1	-



#### Note

In cooling control mode, TUN2 Mode calculates 70% based at 0°.

E.g.) If SV is -100, executes TUN2 at -70.

## 6.4 Alarm output

Alarm output is a relay output that activates irrespective of control output. Alarm output works when the temperature of the controlled subject exceeds or falls below the preset temperature range.

Alarm temperature setting values consist of absolute temperatures or offset temperatures, depending on the alarm output mode.



### Note

Alarm output function is only for TM2 Series.

### 6.4.1 Alarm output target channel

Users can set channels in which alarm output (2 or 4) will be activated.

Setting group	Parameter	Setting range	Factory default	Unit
Alarm Setting	Alarm Target Ch	CH1, CH2, CH1 and CH2, CH1 or CH2	Alarm 1, 3: CH1 Alarm 2, 4: CH2	-



### Note

In case of heating/cooling control, Alarm 1 and Alarm 2 are used as a cooling control output; therefore, they cannot be used as an alarm output.

## 6.4.2 Alarm output operating mode

Select the desired alarm output mode.

Mode	Alarm Output	Description (Factory default)
OFF	_____	<b>No alarm output</b>
AL-1		<b>Deviation high-limit alarm (+F.S.)</b> If PV/SV deviation occurs higher than set value of deviation temperature, alarm output will be ON. High limit deviation temperature can be set in AL1.H/AL2.H/AL3.H/AL4.H.
AL-2		<b>Deviation low-limit alarm (+F.S.)</b> If PV/SV deviation occurs lower than set value of deviation temperature, alarm output will be ON. Low-limit deviation can be set in AL1.H/AL2.H/AL3.H/AL4.H.
AL-3		<b>Deviation high/low-limit alarm (+F.S.)</b> If PV/SV deviation occurs higher than high-limit deviation or lower than low-limit deviation, alarm output will be ON. High-limit deviation can be set in AL1.H/AL2.H/AL3.H/AL4.H. Low-limit deviation can be set in AL1.H/AL2.H/AL3.H/AL4.H.
AL-4		<b>Deviation high/low-limit reverse alarm</b> If PV/SV deviation occurs higher than low-limit deviation or lower than high-limit deviation, alarm output will be ON. High-limit deviation can be set in AL1.H/AL2.H/AL3.H/AL4.H. Low-limit deviation can be set in AL1.H/AL2.H/AL3.H/AL4.H.
AL-5		<b>Absolute value high-limit alarm</b> If PV is higher than the absolute value of temperature, alarm output will be ON. Alarm absolute value can be set in AL1.H/AL2.H/AL3.H/AL4.H.
AL-6		<b>Absolute value low-limit alarm</b> If PV is lower than the absolute value of temperature, alarm output will be ON. Alarm absolute value can be set in AL1.L/AL2.L/AL3.L/AL4.L.
LBA	On if loop break is detected.	<b>Loop break alarm</b>
SBA	On if sensor break is detected.	<b>Sensor break alarm</b>
HBA	On if current transformer (CT) detects heater break.	<b>Heater burnout alarm</b>

Setting group	Parameter	Setting range	Factory default	Unit
Alarm Setting	Alarm Mode	Refer to the above table.	Alarm 1, 3: AL-1 Alarm 2, 4: AL-2	-

### 6.4.3 Alarm output option

Select the desired alarm output option mode.

Setting	Mode	Description
AL-A	Standard alarm	If it is an alarm condition, alarm output is ON. Unless an alarm condition, alarm output is OFF.
AL-B	Alarm latch <sup>*1</sup>	If it is an alarm condition, alarm output is ON. Before reset the alarm, an ON condition is latched. (Holding the alarm output)
AL-C	Standby sequence 1 <sup>*2</sup>	When power is supplied and it is an alarm condition, alarm output does not act. From the second alarm conditions, standard alarm acts.
AL-D	Alarm latch and standby sequence 1	When power is supplied and it is an alarm condition, alarm output does not act. From the second alarm conditions, alarm latch acts.
AL-E	Standby sequence 2	When Standby sequence <sup>*3</sup> and it is an alarm condition, alarm output does not act. After deactivate the alarm condition, standard alarm acts.
AL-F	Alarm latch and standby sequence 2	When Standby sequence <sup>*3</sup> is repeated and it is an alarm condition, alarm output does not act. After deactivate the alarm condition, alarm latch acts.

※1. Alarm Latch: Deactivating Alarm Output in Alarm Latch mode: Turn off the power or send alarm reset signal.

※2. Standby sequence: This option is applied only if PV is in alarm output ON conditions when power is supplied. If not, alarm output will be provided from the first alarm condition same as other alarm operations.

※3. Conditions of repeated Standby sequence: Power ON, Changing SV, Related Alarm(operation mode, option, setting value), Changing Parameter, Changing STOP mode to RUN mode.

Setting group	Parameter	Setting range	Factory default	Unit
Alarm Setting	Alarm Type	Refer to the above table.	AL-A	-



#### Note

- You can set alarm output (Alarm 1 Type to Alarm 4 Type) individually.
- If alarm output mode has been selected as LBA, SBA or HBA, AL-C, AL-D modes are not available.



Ex.

Example of SV: 100°C, alarm output operation mode: AL-3(Deviation high/low-limit alarm),  
alarm option: AL-E(Standby sequence 2),  
(deviation high/low-limit temperature: 10°C, alarm output hysteresis: 5°C)

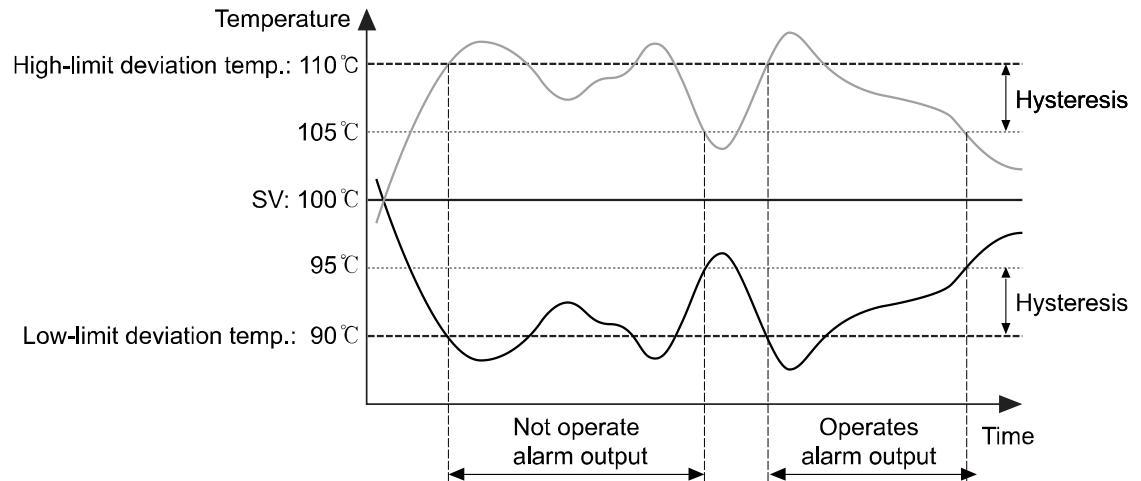

When first alarm condition occurs, alarm output does not operate. From the second alarm condition, alarm output operates.

#### 6.4.4 Alarm SV

You can set alarm output activation values. According to the selected alarm output mode, configuration parameters (AL□.H/AL□.L) will be activated for each setting.

Setting group	Parameter	Setting range	Factory default	Unit
Alarm Setting	Alarm High_Ch Alarm Low_Ch	Deviation alarm: F.S. to F.S. Absolute value alarm: Within the temperature range of input type	1550	°C/°F



Note

Changing the alarm output mode or options resets the settings to the highest or lowest values that will not trigger output in the new mode.

### 6.4.5 Alarm output hysteresis

“H” shown in the image from ‘6.4.2 Alarm output operating mode’ represents the alarm output hysteresis. It is used to set an interval between alarm output ON/OFF periods.

If PV is over or below alarm output SV, output turns ON and it sets OFF time by hysteresis settings.

When input value is changed near SV, alarm output is often. Set hysteresis and it can be prevented from often alarm output.

Can be set individually by alarm output (Alarm 1 Type to Alarm 2 Type).

Setting group	Parameter	Setting range	Factory default	Unit
Alarm Setting	Alarm Hysteresis_Ch	1 to 100 (H), 0.1 to 100.0 (L)	1	Digit



#### Note

- Alarm output hysteresis applies to heater burnout alarm (HBA) in the same manner.
- This parameter does not appear if Loop Break Alarm (LBA) or Sensor Break Alarm (SBA) is selected.

### 6.4.6 Alarm output method

Relay type can be set at alarm output.

- N.O. (Normally Open) stays open when normal and closes in the event of an alarm.
- N.C. (Normally Closed) stays closed when normal and opens in the event of an alarm.

Setting group	Parameter	Setting range	Factory default	Unit
Alarm Setting	Alarm NO/NC	NO, NC	NO	-



#### Note

Front indicators

Change	Alarm occurs	Alarm output	Indicator
N.O.	OFF	Open	<input type="checkbox"/> OFF
	ON	Close	<input checked="" type="checkbox"/> ON
N.C.	OFF	Close	<input type="checkbox"/> OFF
	ON	Open	<input checked="" type="checkbox"/> ON

### 6.4.7 Alarm output delay

Alarm output delay can be set to prevent false alarms caused by erroneous input signals resulting from disturbances or noise.

With a preset delay time, alarm output does not turn on for the preset duration. Instead, the concerned alarm indicator on the front will flash in 0.5-second intervals.

- Alarm ON delay time: Stands by for the preset duration upon an alarm event, checks the alarm trigger conditions, and turns on the alarm output if the conditions are still present.
- Alarm OFF delay time: Stands by for the preset duration following alarm output off, checks the alarm trigger conditions, and turns off the alarm output if the deactivation conditions are still present.

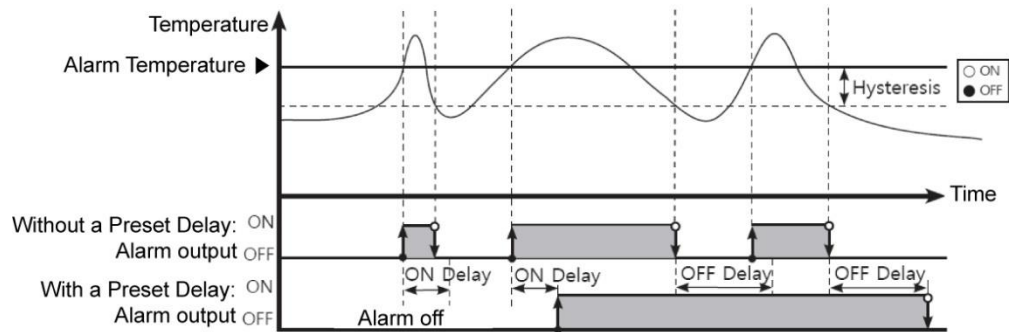

Setting group	Parameter	Setting range	Factory default	Unit
Alarm Setting	Alarm ON Delay Time	0 to 3600	0	Sec.
	Alarm OFF Delay	0 to 3600	0	Sec.

### 6.4.8 Loop break alarm(LBA)

Diagnoses the control loop by monitoring the control subject's temperature changes and sends out alarms if necessary.

- Heating control: When control output MV is 100% or high limit (MV high limit) and PV is not increased over than LBA detection band (LBA Band) during LBA monitoring time (LBA Time), or when control output MV is 0% or low limit (MV low limit) and PV is not decreased below than LBA detection band (LBA Band) during LBA monitoring time (LBA Time), alarm output turns ON.
- Cooling control: When control output MV is 0% or low limit (MV low limit) and PV is not increased over than LBA detection band (LBA Band) during LBA monitoring time (LBA Time), or when control output MV is 100% or high limit (MV high limit) and PV is not decreased below than LBA detection band (LBA Band) during LBA monitoring time (LBA Time), alarm output turns ON.

Common causes of LBA output ON

- Sensor error (disconnection, short)
- External controller error (magnet, auxiliary relay, etc.)
- External load error (heater, cooler, etc.)
- Misconnections and disconnections of external network.

If it is not as sensor break/HHHH/LLLL, during auto-tuning/manual control/control STOP/ramp function operation, loop break alarm does not operate.

Type	LBA monitoring time	Alarm output	
		Standard alarm	Alarm latch
Initializing Alarm, changing control output operation mode, setting LBA monitoring time/band as 0	Initialize	OFF	OFF
Changing input correction value, set value		Maintains the present alarm	Maintains the present alarm
Changing MV, stopping control, running auto-tuning		OFF	Maintains the present alarm
Occurring sensor break alarm, HHHH, LLLL		ON	ON



#### Note

Set alarm output operation mode (Alarm Mode) as loop break alarm (LBA) and you can use loop break alarm.

When executing auto-tuning, LBA detection band (LBA Band) and LBA monitoring time(LBA Time) is automatically set based on auto-tuning value.

In case of AT (auto-tuning)/manual control/stop control, loop break alarm (LBA) does not operate. When alarm reset is input, it initializes LBA monitoring start time.

#### 6.4.8.1 LBA monitoring time

You can set the LBA monitoring time to check changes in the control subject's temperature. Automatically setting with auto-tuning.

- Regardless of alarm output operation mode (Alarm Mode) (including LBA monitoring time as "0"), after running auto-tuning, the integration time×2 value is saved automatically. (If SV is out of the range of auto setting, it is set as max. or min. value of auto setting.)
- Except input type changing, re-running auto-tuning, manual setting of LBA monitoring time, it maintains the present SV.
- Auto setting range: 0020 to 9999

Setting group	Parameter	Setting range	Factory default	Unit
Alarm Setting	LBA Time Ch1, LBA Time Ch2	0000 to 9999	0	Sec

#### 6.4.8.2 LBA detection band

You can set the minimum value of deviation change to decrease during LBA monitoring time. Automatically setting with auto-tuning.

- Regardless of alarm output operation mode (Alarm Mode) (including LBA monitoring time as "0"), after running auto-tuning, the integration time×2 value is saved automatically.
- Except input type changing, re-running auto-tuning, manual setting of LBA monitoring time, it maintains the present SV. (If SV is out of the range of auto setting, it is set as max. or min. value of auto setting.)
- Auto setting range  
Temperature L: 002.0 to 100.0 (°C/°F)  
Temperature H: 0002 to 010.0 (°C/°F)

Setting group	Parameter	Setting range	Factory default	Unit
Alarm Setting	LBA Band Ch1, LBA Band Ch2	0 to 999 (H) 0.0 to 999.9 (L)	2	°C/°F



Ex.

It checks control loop and outputs alarm by temperature change of the subject.

For heating control(cooling control), when control output MV is 100%(0% for cooling control) and PV is not increased over than LBA detection band (LBA Band) during LBA monitoring time (LBA Time), or when control output MV is 0%(100% for cooling control) and PV is not decreased below than LBA detection band (LBA Band) during LBA monitoring time (LBA Time), alarm output turns ON.

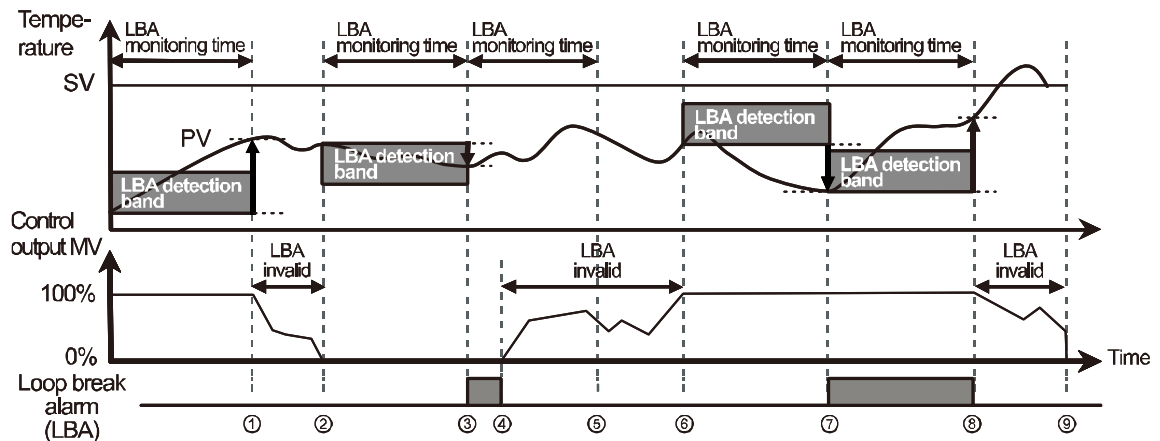

Start to ①	When control output MV is 100%, PV is increased over than LBA detection band (LBA Band) during LBA monitoring time (LBA Time).
① to ②	The status of changing control output MV (LBA monitoring time is reset.)
② to ③	When control output MV is 0% and PV is not decreased below than LBA detection band (LBA Band) during LBA monitoring time (LBA Time), loop break alarm (LBA) turns ON after LBA monitoring time (LBA Time).
③ to ④	Control output MV is 0% and loop break alarm (LBA) turns and maintains ON.
④ to ⑥	The status of changing control output MV (LBA monitoring time is reset.)
⑥ to ⑦	When control output MV is 100% and PV is not increased over than LBA detection band (LBA Band) during LBA monitoring time (LBA Time), loop break alarm (LBA) turns ON after LBA monitoring time (LBA Time).
⑦ to ⑧	When control output MV is 100% and PV is increased over than LBA detection band (LBA Band) during LBA monitoring time (LBA Time), loop break alarm (LBA) turns OFF after LBA monitoring time (LBA Time).
⑧ to ⑨	The status of changing control output MV (LBA monitoring time is reset.)

### 6.4.9 Sensor break alarm

You can set the controller to send out an alarm when a sensor is not connected or disconnected during temperature control. Sensor break can be confirmed through an external alarm output contact, such as a buzzer or similar means.

Setting alarm output mode (alarm mode) to SBA will activate sensor break alarm.



**Note**

Alarm output option can be set to standard alarm (AL-A) or alarm latch (AL-B).

### 6.4.10 Heater burnout alarm

When using a heater to raise the temperature of the control subject, the temperature controller can be set to detect heater disconnection and send out an alarm by monitoring power supply to the heater.

Heater disconnection is detected by the controller using a current transformer (CT), which converts the current to the heater to a specific ratio (CT ratio) for monitoring. If the heater current value (CT-A) measured by the CT is less than the heater detection setting value (Alarm Low\_CH), the heater burnout alarm will activate.

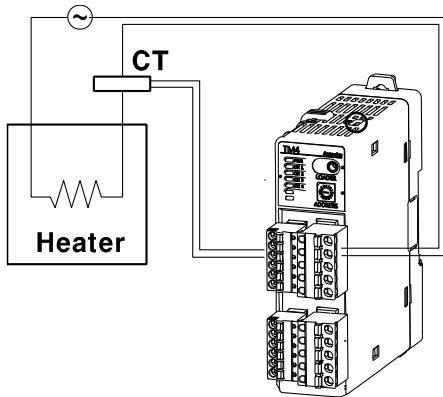

**Note**

- Heater burnout detection only takes place when the temperature controller's output is turned on. Otherwise, heater burnout will not be detected by the controller.
- Availability of the heater burnout alarm function is different by model and control output type.

Model	Control output type	Heater burnout alarm
TM□-□□R□ (Relay output)	Relay output	○
TM4□-□□S□ (SSR drive output)	ON/OFF control	○
	Cycle control	X
	Phase control	X
TK2□-□□C□ (Current or SSR drive output)	Current output	X
	SSR drive output	○

- Current detection is not performed if OUT control output time is less than 250 ms.
- It is recommended to use Autonics designated current transformer (for 50 A).
- Alarm output option can be set to standard alarm (AL-A) or alarm latch (AL-B).

### 6.4.10.1 Heater disconnection detection SV

Set the alarm output value (Alarm Low\_Ch) as the reference value for heater burnout detection.

Setting group	Parameter	Setting range	Factory default	Unit
Alarm Setting	Alarm Low_Ch	0.0 to 50.0	0.0	A



#### Note

Set to 00.0 for OFF. Set to 50.0 for ON.

Setting value calculation

: Heater burnout setting value = {(normal heater current values) + (heater burnout current)}/2



#### Ex.

- If using a single output heater (Capacity: 200 VAC, 1 KW, 5 A), normal heater current is 5 A, and burnout heater current is 0 A, the setting value is calculated as  $(5\text{ A} + 0\text{ A})/2 = 2.5\text{ A}$ . Therefore, heater current values less than 2.5 A (heater burnout setting value) will be deemed heater burnout and the alarm will activate.

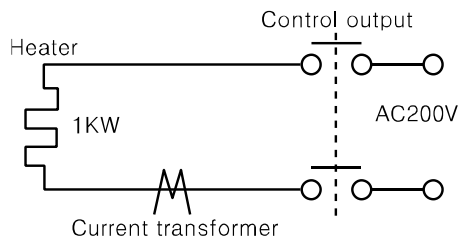

- When two output heaters (Capacity: 200 VAC, 1 KW, 5 A) are used, normal heater current is 10 A ( $5\text{ A} \times 2$ ). If a single heater burns out, the heater current becomes 5A. The setting value is calculated as  $(10\text{ A} + 5\text{ A})/2 = 7.5\text{ A}$ . Heater current values of less than 7.5 A (heater burnout setting value) are deemed heater burnout and the alarm activates.

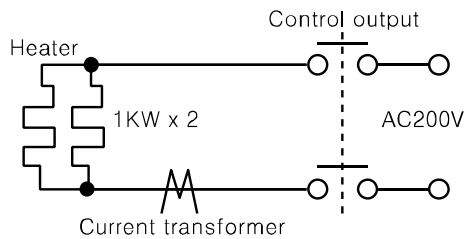

### 6.4.11 Alarm output OFF

Available only if alarm output option is set to alarm latch or alarm latch and standby sequence1, alarm latch and standby sequence2. It can be set to turn off alarm output when alarm output is on, alarm output conditions have been removed, or an alarm output off signal that is greater than the minimal signal band is received. (However, alarm output off is unavailable when alarm conditions remain in effect.)

You can assign the digital input terminals (DI-1, DI-2) for the alarm output off feature.



#### Note

- For more information about digital terminal (DI) setting, please refer to '6.9.1 Digital input terminal '.
- After deactivating the alarm output, it will function normally for the next alarm output occurrence.

### 6.4.12 Alarm output examples

#### (1) Absolute value high-limit alarm and deviation high-limit alarm

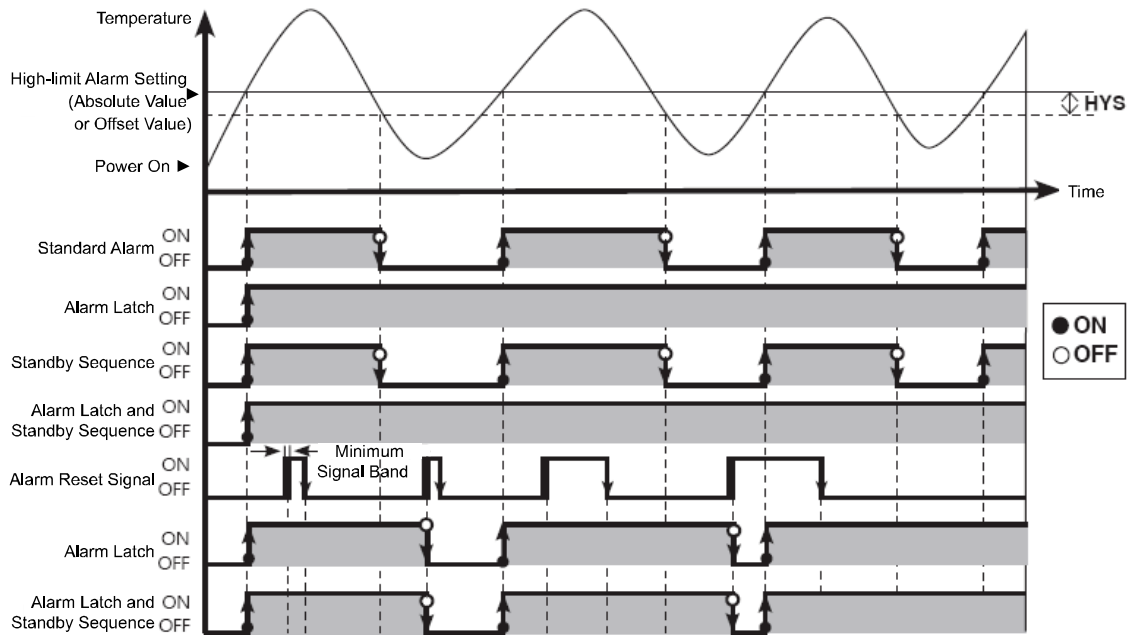

※HYS: Hysteresis

#### (2) Absolute value low-limit alarm and deviation low-limit alarm

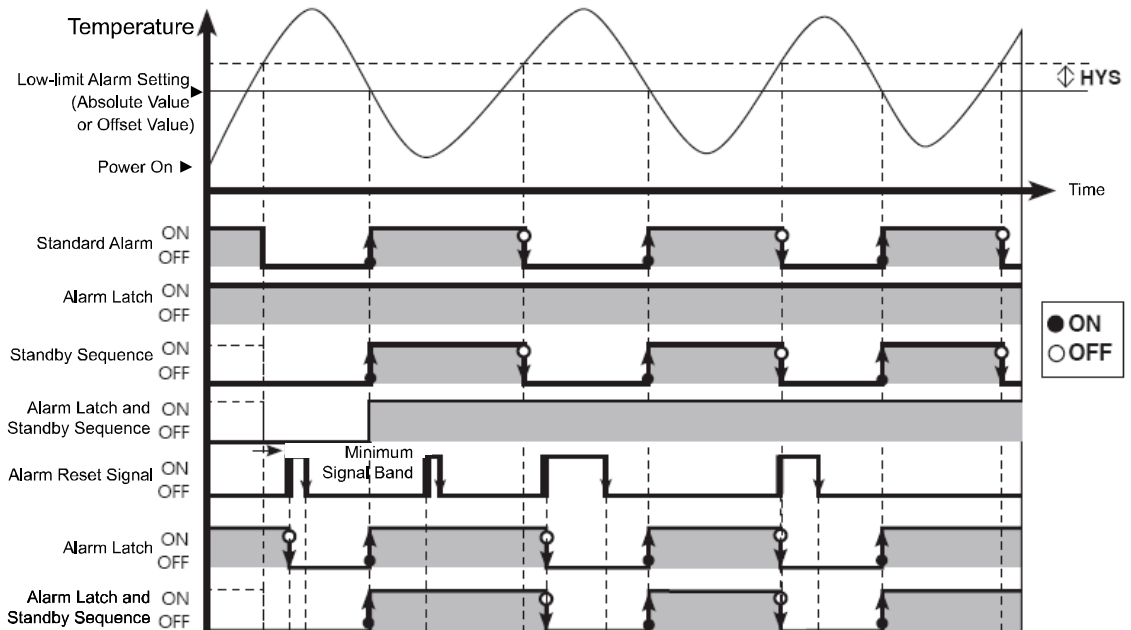

※HYS: Hysteresis

**(3) Deviation high/low-limit alarm**

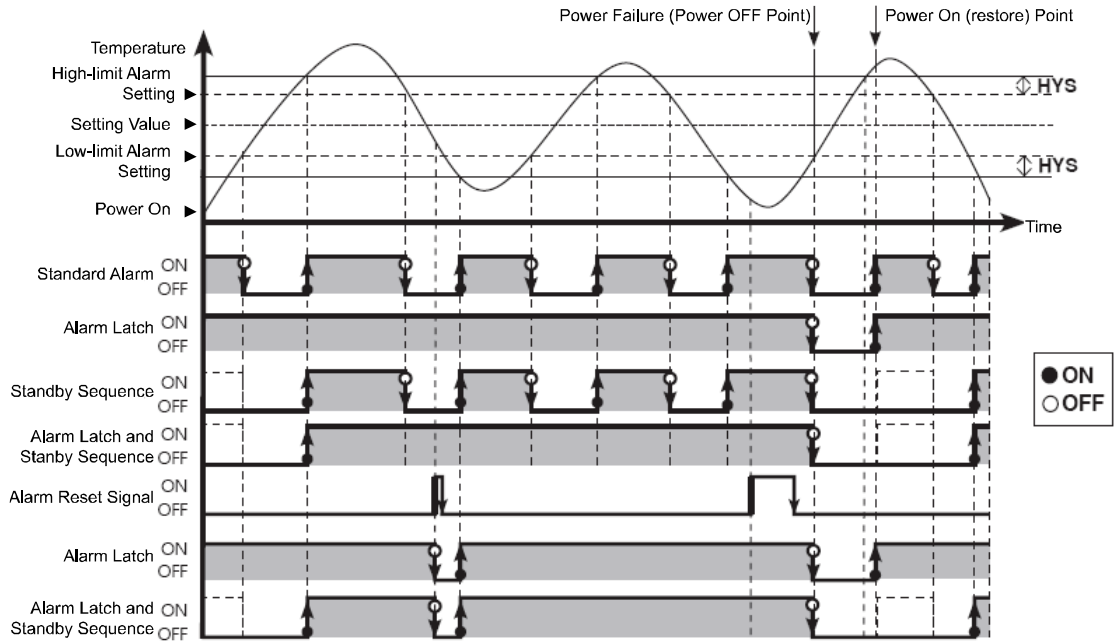

※HYS: Hysteresis

**(4) Deviation high/low-limit reverse alarm**

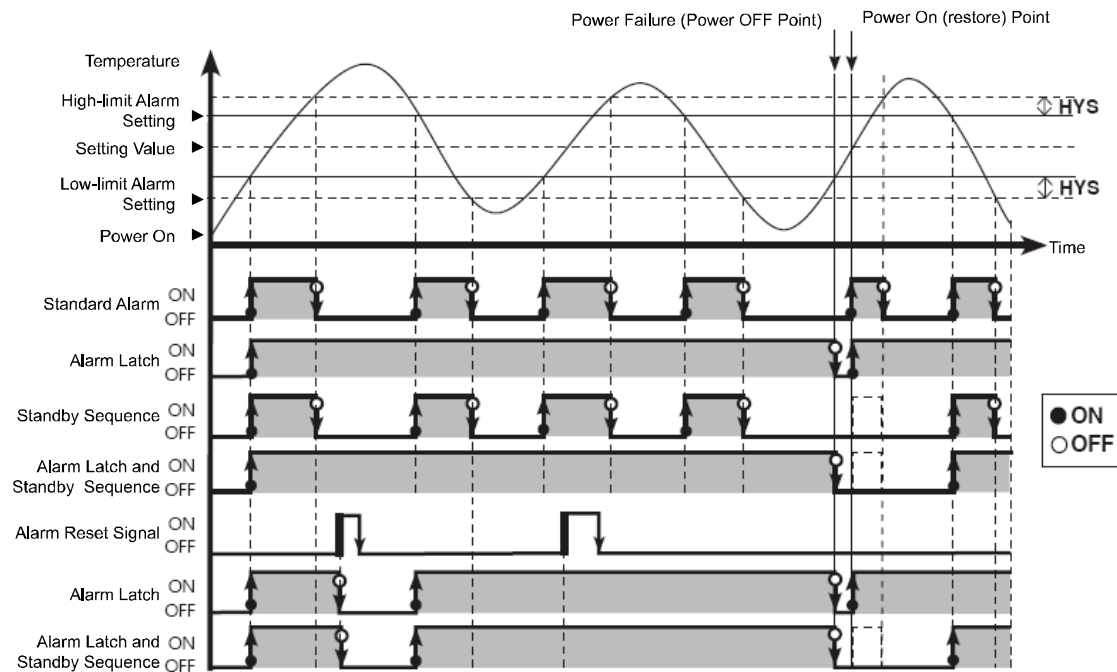

※HYS: Hysteresis

**(5) Deviation high/low-limit alarm (hysteresis overlap)**

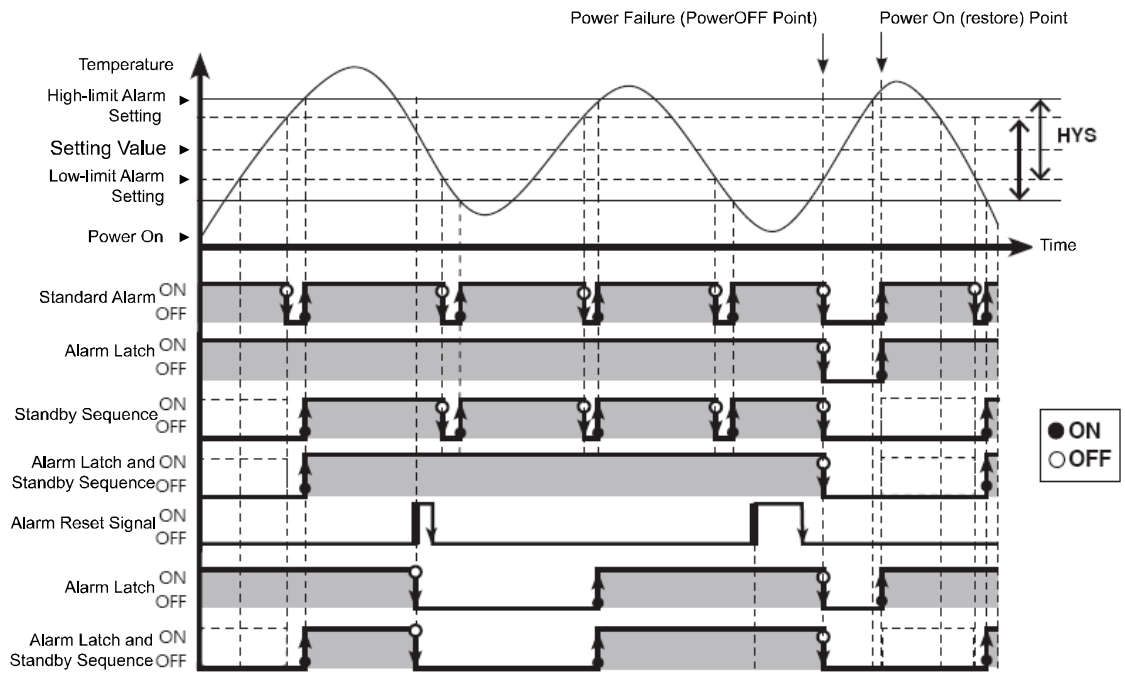

※HYS: Hysteresis

## 6.5 Communications

This feature is used for external higher systems (PC, GP, etc.) to set the controller's parameters and to monitor the controller. It can also be used to external devices.

- No redundant unit addresses may exist along the same communication line.
- The communication cable must be twisted pair that supports RS485.

### (1) Interface

<b>Protocol</b>	Modbus ASCII / RTU
<b>Application standard</b>	EIA RS485 compliance with
<b>Maximum connection</b>	31 units (address: 01 to 31)
<b>Synchronization type</b>	Asynchronous
<b>Connection type</b>	Two-wire half duplex
<b>Comm. effective range</b>	≤ 800 m
<b>Comm. speed</b>	2,400 / 4,800 / 9,600 (default) / 19,200 / 38,400 / 57,600 / 115,200 bps (parameter)
<b>Response time</b>	5 to 99 ms (default: 20 ms)
<b>Start bit</b>	1 bit (fixed)
<b>Data bit</b>	8 bit (fixed)
<b>Parity bit</b>	None (default), Odd, Even
<b>Stop bit</b>	1 bit, 2 bit (default)
<b>EEPROM life cycle</b>	F/W version 500 or higher: ≈1,000,000 operations (Erase / Write) F/W version less than 500: ≈100,000 operations (Erase / Write)

### (2) Communication address

You can assign a unique address to each device.

Users can set communication address using both SW1 (communication address setting switch) and SW2 (communication group change switch).

- Setting range: 01 to 31
- Factory default: [SW1] 1, [SW2] +0

SW2	SW1															
	0	1	2	3	4	5	6	7	8	9	A	B	C	D	E	F
<div style="display: flex; align-items: center;"> <div style="width: 15px; height: 15px; background-color: #cccccc; margin-right: 5px;"></div> <span>+0</span> </div> <div style="display: flex; align-items: center;"> <div style="width: 15px; height: 15px; background-color: #cccccc; margin-right: 5px;"></div> <span>+16</span> </div>	<del>00</del>	01	02	03	04	05	06	07	08	09	10	11	12	13	14	15
<div style="display: flex; align-items: center;"> <div style="width: 15px; height: 15px; background-color: #cccccc; margin-right: 5px;"></div> <span>+0</span> </div> <div style="display: flex; align-items: center;"> <div style="width: 15px; height: 15px; background-color: #cccccc; margin-right: 5px;"></div> <span>+16</span> </div>	16	17	18	19	20	21	22	23	24	25	26	27	28	29	30	31



#### Note







If 00 is designated, communications are not performed.

### 6.5.1 Communications speed settings

You can set the rate of data transmission.

Setting group	Parameter	Setting range	Factory default	Unit
Communication Setting	Baudrate	2,400 / 4,800 / 9,600 / 19,200 / 38,400 / 57,600 / 115,200	9600	bps

- A display LED corresponding to the current bps flashes for 5 seconds (1 second intervals) when the power supply is initially ON.

Indicator	TM2 Series	TM4 Series	BPS (Bits Per Second)
	PWR	PWR	-
	CH1	CH1	4800
	CH2	CH2	9600
	AL1	CH3	19200
	AL2	CH4	38400
	AL3	-	57600
	AL4	-	115200



#### Note

- It is required to reset controller's POWER (Power OFF -> Power ON) after changing communication speed (bps) via Power/Comm. connection terminal.
- One module communication is allowed for PC loader port. Communication speed is fixed to 9600 bps.
- Make sure that each module has its own communication address. If there are overlapping addresses, parameters for overlapping module cannot be monitored and it may affect the whole communication speed.

### 6.5.2 Communications parity bit

Parity bit is a data communication method that adds an additional bit to each character in transmitted data as an indicator used to verify data loss and corruption. This parameter is used to enable or disable the parity bit option.

SV (setting value)	Description
NONE	Disables parity bit.
EVEN	Sets the total bits with signal value of 1 as even numbers.
ODD	Sets the total bits with signal value of 1 as odd numbers.

Setting group	Parameter	Setting range	Factory default	Unit
Communication Setting	Parity Bit	NONE, EVEN, ODD	NONE	-

### 6.5.3 Communication stop bit

You can set the number of bits to mark the end of a transmitted data string.

Setting value	Description
1	Sets end of data string to 1 bit.
2	Sets end of data string to 2 bit.

Setting group	Parameter	Setting range	Factory default	Unit
Communication Setting	Stop Bit	1, 2	2	-

### 6.5.4 Response wait time

Set a standby time to mitigate communication errors when communicating with a slow master device (PC, PLC, etc.). Once a standby time is set, the controller will respond after the defined standby time has elapsed.

Setting group	Parameter	Setting range	Factory default	Unit
Communication Setting	Response Wait Time	5 to 99	20	ms



#### Note

Shorter standby times can cause communication errors in the master device.

### 6.5.5 Enable/Disable communications writing

This feature can change parameter settings stored in memory through communication with PC, GP, PLC, etc., in order to permit or prohibit writing.

Setting value	Description
ENABLE	Parameter set/change enable via communication.
DISABLE	Prohibit parameter setting or modification via communication.

Setting group	Parameter	Setting range	Factory default	Unit
Communication Setting	Communication Write	ENABLE, DISABLE	ENABLE	-



#### Note

Reading parameter settings is always permitted.

### 6.5.6 Communication Protocol

Set the communication protocol.

Setting group	Parameter	Setting range	Factory default	Unit
Communication Setting	Communication Protocol	RTU, ASCII	RTU	-

### 6.5.7 USB-to-Serial connection

Data can be transmitted via a USB-to-serial connection. However, RS485 communication through a USB-to-serial connection is blocked by hardware.

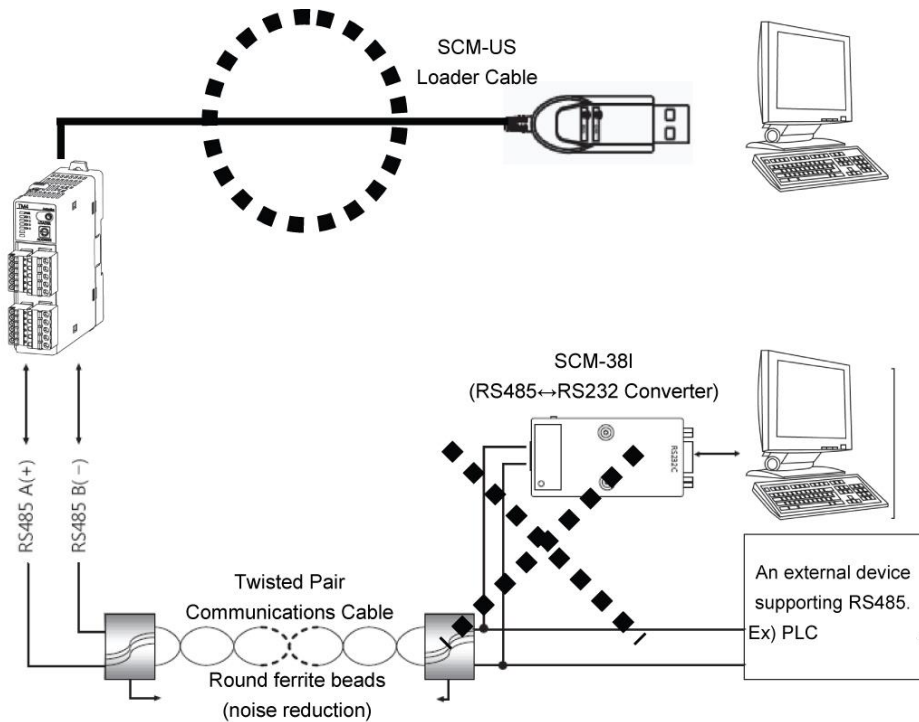

## 6.6 Monitoring function

### 6.6.1 Control output MV monitoring

Monitors and displays the current control output MV.

### 6.6.2 Heating MV monitoring

Displays the current heating MV during heating control or heating and cooling control. Users may manually adjust the MV to control the temperature.

- Measurement range: 0.0 to 100.0%

### 6.6.3 Cooling MV monitoring

Displays the current cooling MV during cooling control or heating and cooling control. Users may manually adjust the MV to control the temperature.

- Measurement range: 0.0 to 100.0%

### 6.6.4 Heater current monitoring

A feature that monitors and displays the current of a heater (load) being controlled by control output.

- Measurement range: 0.0 to 50.0A



#### Note

The current value of a heater (load) is measured and displayed through the current transformer.

Setting group	Parameter	Setting range	Factory default	Unit
Monitoring	Heating_MV	0.0 to 100.0	-	%
Monitoring	Cooling_MV	0.0 to 100.0	-	%
Monitoring	CT1_Heater Current	0.0 to 50.0	-	A
Monitoring	CT2_Heater Current	0.0 to 50.0	-	A

Availability of the heater current monitoring function is different by model and control output type.

Model	Control output type	Heater current monitoring
TM□-□□R□ (Relay output)	Relay output	○
TM4□-□□S□ (SSR drive output)	ON/OFF control	○
	Cycle control	X
	Phase control	X
TM2□-□□C□ (Current or SSR drive output)	Current output	X
	SSR drive output	○

## 6.7 Run/Stop function

Users may run or stop control output by force while in Run mode.

The STOP command stops the control output. Alarm output, other than control output, maintains the values as set in the alarm output setting at the point of STOP.

This feature can be enabled by configuring parameters. The digital input terminals (DI-1 and DI-2) can be assigned to the run/stop feature.



### Note

- Modifications on RUN/STOP are allowed even when in open state. The STOP status will remain in effect after shutting down the controller and powering it back on.
- When STOP is in effect, MV based on the control output at the point of STOP (Stop.MV) is displayed, and continues to be displayed even if a sensor break occurs.
- When restarting after STOP, the initial MV is the MV at the end point.
- The run/stop setting remains in effect after turning power back on.

### 6.7.1 Control output for STOP

This sets the control output value upon a STOP. With ON/OFF control, select between 0.0 (OFF) and 100.0 (ON). In PID control, you can directly choose MV within a range of 0.0 to 100.0.

Setting group	Preceding condition		Parameter	Setting range	Factory default	Unit
Control Setting	Heating, Cooling	PID	Stop MV	0.0 to 100.0	0.0	%
		ON/OFF		0.0 (OFF)/100.0 (ON)		
	Heating & Cooling	PID		-100.0 (Cool) to 100.0 (Heat)	0.0	
		ON/OFF		-100.0 (Cool ON) /0.0 (OFF) /100.0 (Heat ON)		



### Note

When set to STOP, the preset MV is used for output ignoring the MVs from ON/OFF control and PID control.

### 6.7.2 Alarm output for STOP

Enable or disable alarm output upon a stop.

- CONTINUE: Alarm output operates normally.
- OFF Alarm output ceases along with a stop under all conditions. (However, reverting to Run mode after a stop in alarm latch or alarm latch and standby sequence restores the alarm output to the previous state.)

Setting group	Parameter	Setting range	Factory default	Unit
Control Setting	Stop Alarm Out	CONTINUE, OFF	CONTINUE	-

## 6.8 Multi SV

Multi SV function allows users to set multiple SVs and save each setting in SV0 to SV3. User can change Multi SV number or select desired SV using external DI (Digital Input, DI-1, DI-2) terminal.

This feature supports up to four SVs which can be independently configurable.

### 6.8.1 Number of multi SVs

You can set the number of Multi SVs. Select the number of Multi SVs from the controlled subject.

Number of SVs	SV Setting
1	SV-0
2	SV-0, SV-1
4	SV-0, SV-1, SV-2, SV-3,

### 6.8.2 Multi SV No. settings

You can select the SV to desired control.



#### Note

The SV No. selection range varies according to the number of multi SVs.

### 6.8.3 SV for Multi SVs

Designate the value of each SV for Multi SVs.

Setting group	Preceding condition	Parameter	Setting range	Factory default	Unit
Control Setting	-	Multi SV	1EA, 2EA, 4EA	1EA	Numbers
Control Operation	Multi SV	Multi SV No.	SV-0 to SV-3	SV-0	-
Control Operation	Multi SV	SV-0 to SV-3	SV Low-limit to SV High-limit	0	℃, °F

## 6.9 Digital input

### 6.9.1 Digital input terminal settings

When send the signal to the external digital input (DI-1, DI-2) terminal, the settings of the digital input  $\square$ \_Func parameter will perform. When powers on, it will activate after checking the digital input terminal.

Setting value	Description
OFF	No function.
STOP	If DI-1,DI-2 terminals are shorted, the stop feature will perform, but to change run/stop through communication will not perform.
AL-RESET	If DI-1,DI-2 terminals are shorted, the forced deactivation of alarm output will perform, but to deactivate the alarm output through communication will not perform.
Manual	If DI-1,DI-2 terminals are shorted, the manual control feature will perform, but to change auto/manual control through communication will not perform.
Multi-SV	By combinational logic of the digital input(DI-1,DI-2), it is possible to select multi SV NO. (SV-0 to SV-3), but it is not possible to select multi SV NO. through communication.

- In the case one of DI-1 or DI-2 being set for Multi SV, SV-0 is selected as the SV if the terminal's external contact signal is off and SV-1 is selected if the signal is on.
- If both DI-1 and DI-2 are configured for Multi SV, you can select the SV using combinational logic of the terminals. If changes multi SV from 4 to 2, the DI-2 will be automatically turned off. If changes multi SV from 4 to 1, both DI-1 and DI-2 will be turned off.

DI-1	DI-2	Multi SV No.
OFF	OFF	SV-0
ON	OFF	SV-1
OFF	ON	SV-2
ON	ON	SV-3

Setting group	Parameter	Setting range	Factory default	Unit
Digital Input Setting	Digital Input 1 Func	OFF, STOP, AL-RESET Manual, Multi-SV	OFF	-
	Digital Input 2 Func		OFF	-



#### Note

Multi SV parameter will be activated only if Multi SV is more than 2.

### 6.9.2 Digital input terminal target channel

Users can set a target channel to which digital input terminal function will be applied.

Setting group	Parameter	Setting range	Factory default	Unit
Digital Input Setting	Digital Input1 Ch	CH1, CH2	CH1	-
	Digital Input2 Ch		CH2	-

## 6.10 Error

The controller diagnoses input signals for errors and displays messages accordingly. These messages inform the user of device problems. Once the cause of the error is solved (sensor connected/return to display range), the error status is released and the device continues to run normally.

- The following conditions may result in errors. When an error occurs, the display LED at the front flashes at 0.5 second intervals.
  - The sensor input is higher than operational temperature range.
  - The sensor input is lower than operational temperature range.
  - Input sensor is disconnected or not connected.



### Note

- When power is on, or in standard control or heating mode, the controller outputs 0% if HHHH is displayed and 100% if LLLL is displayed.
- When power is on, or in standard control or cooling mode, the controller outputs 100% if HHHH is displayed and 0% if LLLL is displayed.
- In heating and cooling mode, when power is on or in standard control, heating output is 0% and cooling output is 100% if HHHH is displayed; heating output 100% and cooling output is 0% if LLLL is displayed.
- Output priority in manual control: Heating(Cooling)\_MV > Stop\_MV > Sensor Error\_MV
- Output priority in automatic control: Stop\_MV > Sensor Error\_MV > Heating(Cooling)\_MV

### 6.10.1 Sensor error, MV setting

This feature sets control output when a sensor open error occurs. Users can configure ON/OFF, MV settings, etc.

Ignores MV by ON/OFF control or PID control, and sends out a control value based on the defined MV.

Setting group	Preceding condition		Parameter	Setting range	Factory default	Unit
Control Setting	Heating, Cooling	PID	Sensor Error MV	0.0 to 100.0	0.0	%
		ON/OFF		0.0 (OFF)/100.0 (ON)		
	Heating & Cooling	PID		-100.0 (Cool) to 100.0 (Heat)	0.0	
		ON/OFF		-100.0 (Cool ON) /0.0 (OFF) /100.0 (Heat ON)		

## 6.11 Parameter initialization

This option resets all parameters in memory to factory defaults.

Setting group	Parameter	Setting range	Factory default	Unit
Communication Setting	Parameter Initialize	YES, NO	NO	-



### Note

If selecting "Yes", all parameters will be initialized and temperature control will be by factory default.

However, communication parameters are not initialized.

## 7 Simple Error Diagnosis

### 7.1 Error display

Indicator \ Status	Disconnected input sensors	Out of temperature range
PWR (red)	ON	
CH□ (red) <sup>※1</sup>	Flash (for 0.5 sec. in turn)	
Comm. output (decimal)	Outputs '31000'	Outputs '30000(high-limit)', '-30000(low-limit)'
DAQMaster	Displays 'OPEN'	Displays 'HHHH(high-limit)', 'LLLL(low-limit)'

※1. The applied CH LED indicator flashes.

### 7.2 Troubleshootings

#### (1) LED indicators flash (for 0.5 sec. in turn), or external device displays OPEN

- Check input sensor setting.
- Disconnect the power and check the input connection.
- If input is connected, disconnect the input wiring from the temperature controller and short the + and - terminals. Power the temperature controller and check if the external device displays the room temperature. If it does not display the room temperature and continues to display HHHH or LLLL, the controller is broken. Please contact our technical support. (input type is thermocouple)

#### (2) Output does not operate normally.

- Check that CH indicators for control output operates normally.
- If CH indicators for control output does not operates, check the parameter settings.
- If CH indicators for control output operates, remove the control output connector and check the output.

#### (3) External device receives no-response or abnormal data.

- Check the communication converter (SCM-38I, SCM-US48I or SCM-US, sold separately).
- Do not install communication converter line and AC power supply lines.
- Use different communication converter power and temperature controller power.
- Indicates damage to internal chip by strong noise.
- Please contact our technical support. Locate the source of the noise device countermeasures.

#### (4) Communication does not work between TM and external device

- Check the communication converter power and connections.
- Check the communication settings.
- Check the temperature controller and external device connections.



## 8 DAQMaster

### 8.1 Overview

DAQMaster is a comprehensive device management program that can be used with Autonics communication supporting products.

DAQMaster provides GUI control for easy and convenient management of parameters and multiple device data monitoring.

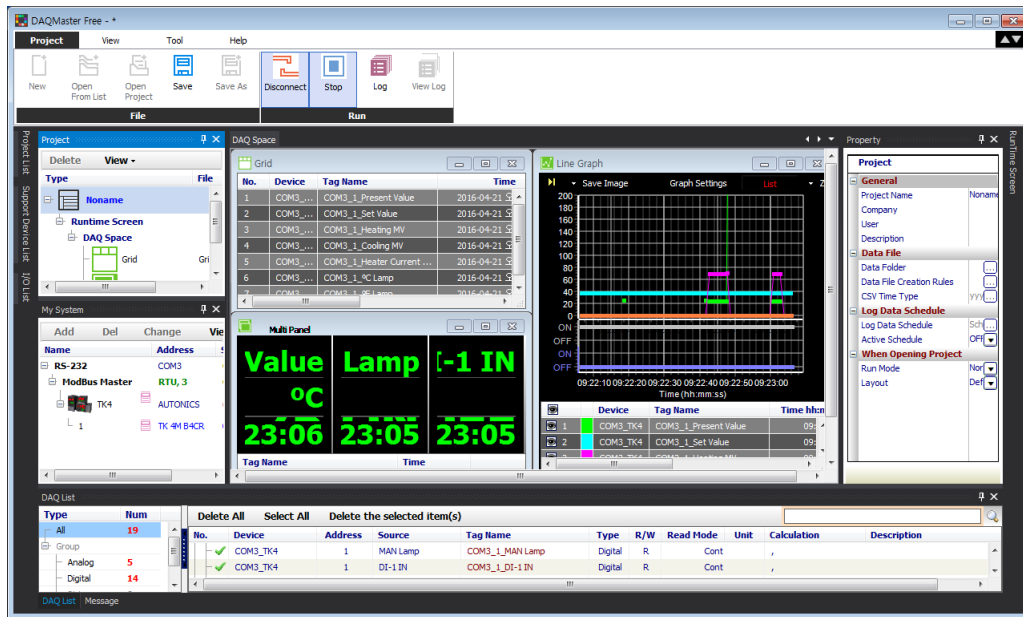

#### Note

For more information, visit our website ([www.autonics.com](http://www.autonics.com)) to download "DAQMaster user manual".

## 8.2 Features

### (1) DAQMaster Pro Version Feature

- Data Base  
Database managing system (Access, MySQL, SQL Server, Oracle, SQLite) turns information into database in real-time, making creation and management of database easier.
- Real-time Logging  
At the set cycle and condition, real-time log file is generated in CSV file.
- Modbus Device Editor  
You can add the any modbus devices which are not supported at DAQMaster to set and monitor the property and I/O.
- OPC Client  
It is Interface method for better compatibility among application programs based on OLE/COM and DCOM technology of Microsoft. It provides industry standard mechanism for communication and data conversion between client and server.
- DDE Client  
It supports communication (IPC) among process embedded in Microsoft Window system, allowing application programs to share and exchange information. This function uses shared memory and provides a common protocol (instruction set and message format) to application programs.

### (2) Features

- Multiple Device Support  
Simultaneously monitor multiple devices and set parameters. Simultaneously connect units with different addresses in a single device. Multiple RS-232 ports are available for communications using Modbus remote terminal unit.
- Device Scan  
In cases of multiple units (with different addresses) connected together, the unit scan function automatically searches for units.
- Convenient User Interface  
Freely arrange windows for data monitoring, properties, and projects. Saving a project also saves the screen layout.
- Project Management  
Saving data as a project file includes added device information, data monitoring screen layouts, and I/O source selection. When you open the project file, the last state of the saving moment will be loaded. Organizing project list makes managing project files easier.
- Data Analysis  
Performs grid and graph analyses of data files (\*.ddf) using data analysis feature of DAQMaster. Saves grid data in .rtf, .txt, .html, or .csv files in Data Grid.
- Monitoring Data Log  
When monitoring, data log files can be saved in either DAQMaster data files (.ddf) or CSV (.csv) files. Open files saved in .csv format directly from Microsoft Excel. Define log data file naming/saving rules and destination folders to make file management convenient.
- Tag Calculation Editing  
Read tag value is available to calculate the set formula for the desired value.

- **Print Modbus Map Table Report**  
Print address map reports of registered Modbus devices. Modbus map table reports can be saved in html (\*.html) and pdf (\*.pdf) formats.
- **Multilingual Support**  
Supports Korean, English, Japanese, and Simplified Chinese. To add a different language, modify the files in the Lang folder rename, and save.
- **Script Support**  
Uses the Lua Script language and deals with different I/O processes for individual devices.

## 8.3 Firmware version

### (1) Major changed firmware version

- [SW version 5.03, HW version 2.00]
  1. Adds Comm. speed (115200 bps)
  2. Adds Comm. protocol Modbus ASCII
  3. Adds User group parameter
- [SW version 5.10, HW version 2.00]
  1. Adds RTD (Cu50Ω, Cu100Ω, DPt50Ω, Nickel 120Ω)

Make Life Easy: **Autonics**

\* Dimensions or specifications on this manual are subject to change and some models may be discontinued without notice.