

Specifications	
Power Supply	24 VAC/DC External Power (20-45 VDC), <2VA Use Class 2 power supply
Input	15V (for monitoring 12VDC) and 50V (for monitoring 24, 36, 48VDC), not to exceed 600VDC
Output	4-20mA proportional; capped at 24mA max
Response Time	250ms (to 90% value)
Accuracy	<1%
Linearity	<0.5%
Output Loading	500Ω maximum
Isolation Voltage	2500 Volts per UL
Frequency Range	DC
Operating Temperature	-4 to 122°F (-20 to 50°C) (surrounding sensor)
Case	UL94V-0 Flammability Rating
Environmental	Operating temperature: -4 to 122°F (-20 to 50°C)
	Relative humidity: 0-95% RH, Non-condensing
	Pollution Degree 2
	Altitude to 2000 meters
Agency Approvals	UL/cUL (E222847) Listed, CE

For products intended for the EU market, the following is applicable to the CE compliance of the product:

The VDCT series comply with EN61010-1 CAT III 600V max measurement category. Use 24V input power and fuse at 5 amps. Power source overvoltage category I as defined per EN 61010-1.



WARNING! RISK OF DANGER:

SAFE OPERATION CAN ONLY BE GUARANTEED IF THE SENSOR IS USED FOR THE PURPOSE FOR WHICH IT WAS DESIGNED AND WITHIN THE LIMITS OF THE TECHNICAL SPECIFICATIONS. WHEN THIS SYMBOL IS USED, IT MEANS YOU MUST CONSULT ALL DOCUMENTATION TO UNDERSTAND THE NATURE OF POTENTIAL HAZARDS AND THE ACTION REQUIRED TO AVOID THEM.



WARNING! RISK OF ELECTRICAL SHOCK:

WHEN OPERATING THE SENSOR CERTAIN PARTS MAY CARRY HAZARDOUS VOLTAGE (E.G. PRIMARY CONDUCTORS, POWER SUPPLY). THE SENSOR SHOULD NOT BE PUT INTO OPERATION IF THE INSTALLATION IS NOT COMPLETE.

Part Number Key

VDCT 015 - 42 - 24

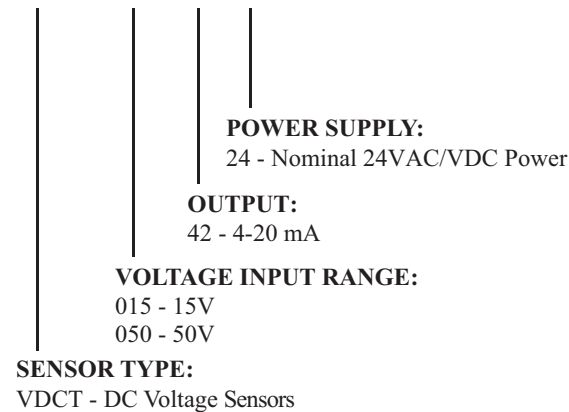

VDCT SERIES INSTALLATION INSTRUCTIONS



Quick Start Guide

1. Ensure correct sensor model was chosen for input voltage of application.
2. Mount the sensor to a DIN rail using integrated mounting clip on backside of sensor.
3. Connect input voltage to be monitored to terminals -(5) & +(6) using 30AWG (0.051mm²) up to 10AWG (5.26mm²) and output and power supply wiring using 24AWG (0.2mm²) up to 14AWG (2.5mm²) copper wires insulated to 75/90°C.
4. Connect 24VAC or DC power supply fused to 5 amp to term. 3-4. Use twisted pair for CE compliance.



AutomationDirect.com (ADC)
3505 Hutchinson Road, Cumming, GA 30040
Phone: (800) 633-0405 or (770) 889-2858
Fax: (770) 889-7876

Description

VDCT Series Voltage Sensors are designed to monitor DC voltage and detect conditions where supply voltage is above or below normal. Detecting such conditions helps users to avoid problems commonly associated with voltage irregularities such as motor overheating, brownouts and conductor failure or poor connections.

The VDCT is available with a 4-20mA output as standard.

Installation

VDCT sensors feature a 35mm wide DIN rail compatible enclosure and are typically located in the same environment as motors, contactors, heaters, pull-boxes, and other electrical enclosures.

To mount on DIN rail:

Orient sensor so that line voltage terminals 5 and 6 are upright/on top of unit and snap securely onto DIN rail. To remove, insert small screwdriver into depression on top of unit and pry orange mounting tab up until unit dislodges from DIN rail.

To mount using screws:

Insert small screwdriver into depression in top of unit and pry orange mounting tab up to reveal mounting hole. Continue to pry tab up until it extends and snaps into place, about 0.25". Insert screws and mount to back plane or other suitably flat surface.

Monitored DC Voltage Wiring Connection



CAUTION: TO AVOID ANY POTENTIAL FOR SHOCK OR SAFETY HAZARD, ENSURE LINE VOLTAGE IS DISCONNECTED AT SOURCE BEFORE WIRING TO UNIT.

Connect input voltage to be monitored to terminals -(5) and +(6) on sensor using 30AWG (0.051mm²) up to 10AWG (5.26mm²) copper wires and tighten terminals to 7 in lbs (0.8 Nm) torque.

If the primary voltage is 24 volts DC nominal, it can be used to power the sensor. If desired, and isolation between output signal and power supply is not needed, connecting the negative of the output (2) with power supply terminal is allowable.

Use twisted pair for power supply conductors for full compliance with CE directives.

Output Wiring

Connect output and power supply wires to the sensor. Use 24AWG (0.2mm²) up to 14AWG (2.5 mm²) copper wire insulated to 75/90°C and tighten terminals to 7 in lbs (0.8 Nm) torque.

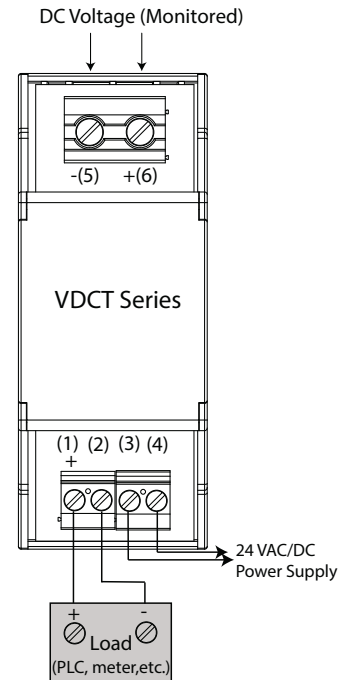

Sensor Output vs. Input Voltage

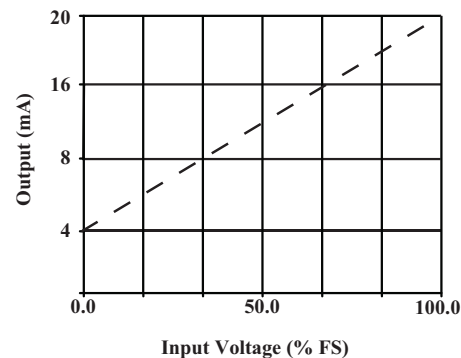

Troubleshooting

1. Sensor has no output
 - A. Power supply is not properly sized.
Check power supply voltage and output rating. Each sensor requires less than 2VA to operate.
 - B. Polarity is not properly matched.
Check and correct wiring polarity.
2. Output Signal is too low or too high
 - A. Sensor is improperly sized for application.
Determine the normal operating voltage of your monitored circuit and ensure sensor selected is equal to or slightly higher than the normal operating voltage.
3. Sensor is always at 4mA
 - A. Primary circuit is not DC or is not on.
Check that the monitored load is DC and that it is actually on.
4. Sensor is always at 20mA
 - A. Voltage is higher than sensor range.
Select a higher range product.