

DRIVE QUICK START GUIDE



IRONHORSE®

ACG AC DRIVE

This quick start reference is included in the VFD packaging and is meant to be a supplement to the User Manual, which is available for free download at Automationdirect.com. This reference informs the installer of the proper steps for mounting, wiring, and basic programming/operation of the ACG VFD up to 22kW/30HP.

CAUTION: IMPROPER WIRING AND OPERATION MAY RESULT IN SERIOUS PERSONAL INJURY OR DEATH

Follow the recommended wiring practices suggested in this document as well as in the User Manual. The minimum size of the protective earth (ground) conductor must comply with local safety regulations and applicable codes.

Please review all ACG related documents included with the product before proceeding with any installation and wiring.

STEP 1 – ACG MODEL NUMBER AND MOUNTING

MODEL NUMBER

Verify that you have the appropriate VFD by checking the nameplate information. Use the example name plate below to assist you with this. The model number and specifications will depend on the drive.

MODEL : ACG-20P5				IE2 (1.4%)	
INPUT	200-240V	3 Phase	50/60Hz		
	HD: 2.2A	ND: 3.0A			
OUTPUT	0-Input V	3 Phase	0.01-400Hz		
	HD: 2.5A	ND: 3.1A			
	1.9kVA (D)	IP 20			
	Ser. No 550E1042ABC Inspected by S.G. SHIN 60400001AD				MADE IN KOREA
IRONHORSE Automationdirect.com					

DIMENSIONS

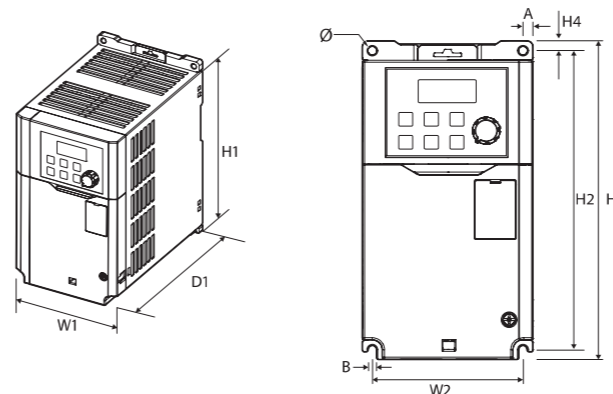

NOTE: Verify that the input voltage rating matches the voltage source applied to the VFD.

NOTE: Drive diagram (Frame A) is a reference for dimensions chart below. See manual for specific Drive Frame diagrams as they differ slightly

NOTE: Confirm that the output power of the VFD is equal to or greater than the rating of the motor which will be connected. Ratings for single-phase input power can be found in the manual.

		Dimensions									
Frame	Part no	W1	W2	H1	H2	H3	H4	D1	A	B	Ø
A	ACG-20P5	86.2 (3.39)	76.2 (3.00)	154 (6.06)	154 (6.06)	164 (6.46)	5 (0.20)	131.5 (5.18)	5 (0.20)	4.5 (0.18)	4.5 (0.18)
	ACG-21P0										
	ACG-40P5										
	ACG-41P0										
B	ACG-22P0	101 (3.98)	90 (3.54)	167 (6.57)	167 (6.57)	177 (6.97)	5 (0.20)	150.5 (5.93)	5 (0.20)	4.5 (0.18)	4.5 (0.18)
	ACG-23P0										
	ACG-42P0										
	ACG-43P0										
C	ACG-25P0	135 (5.31)	125 (4.92)	183 (7.20)	183 (7.20)	193 (7.60)	5 (0.20)	150.5 (5.93)	5 (0.20)	4.5 (0.18)	4.5 (0.18)
	ACG-45P0										
D	ACG-27P5	180 (7.09)	Top: 162 (6.38) Bottom: 170 (6.70)	220 (8.66)	229.5 (9.04)	240 (9.45)	5.5 (0.22)	144 (5.67)	Top: 9 (0.35) Bottom: 5 (0.20)	4.5 (0.18)	Φ-1: 4.5 (0.18) Φ-2: 9 (0.35)
	ACG-2010										
	ACG-47P5										
	ACG-4010										
E	ACG-2015	180 (7.09)	157 (6.18)	290 (11.4)	273.7 (10.8)	290 (11.4)	11.3 (0.44)	173 (6.81)	8.5 (0.33)	4.5 (0.18)	Φ-1: 4.5 (0.18) Φ-2: 8.5 (0.33)
	ACG-2020										
	ACG-4015										
	ACG-4020										
F	ACG-4025	220 (8.66)	193.8 (7.63)	345 (13.6)	331 (13.0)	345 (13.6)	8 (0.31)	187 (7.36)	10.1 (0.40)	5.5 (0.22)	Φ-1: 5.5 (0.22) Φ-2: 11 (0.43)
	ACG-4030										

Units: mm (in)

MOUNTING

When selecting an installation location consider the following points:

- The drive must be installed on a wall or panel that can support the drive's weight.
- The location must be free from vibration. Vibration can adversely affect the operation of the drive.
- The drive can become very hot during operation. Install the drive on a surface that is fire-resistant or flame-retardant and with sufficient clearance around the drive to allow air to circulate. The illustrations below detail the required minimum installation clearances.

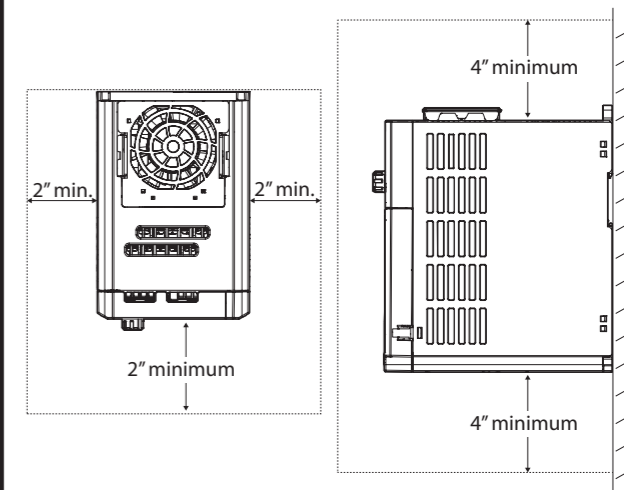

COVER REMOVAL

After mounting, fully loosen all screws from the cover and lift from the bottom.

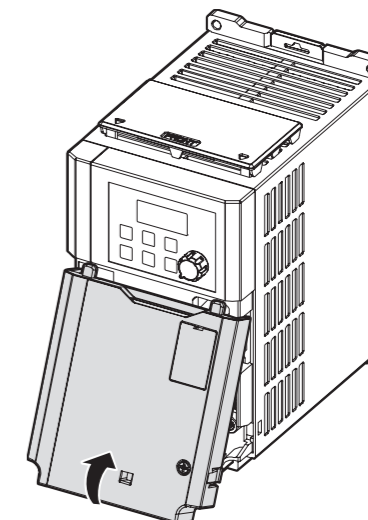

STEP 2 – CONNECT LINE AND MOTOR POWER

Use the wiring diagrams below to properly wire the main power connections to the VFD. This step should be done with power OFF! Refer to the User Manual for additional wiring recommendations. Be sure to follow good wiring and grounding practices. Follow applicable local codes if needed.



DANGER: LETHAL VOLTAGES ARE PRESENT. BE SURE THAT ALL POWER IS TURNED OFF WHILE PERFORMING THE RECOMMENDED POWER WIRING. REINSTALL ALL PROTECTIVE COVERS ON THE ACG BEFORE REAPPLYING POWER

Proper wiring for 3-Phase applications is shown below. The physical terminal layout varies according to frame size. Terminal names (e.g. R, S, T, etc) will remain consistent.

THREE PHASE INPUT

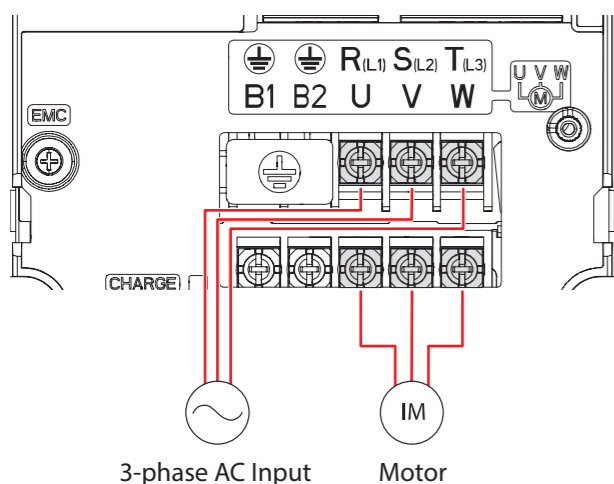

3-phase AC Input

Motor

NOTE: For single-phase input, any two of the R, S, T terminals may be used.



B1 and B2 terminals should not be connected to power or ground.

Part Number	Power Terminal Screw Size	Screw Torque (Nm)	Recommended Wire size AWG (mm ²)	
			Power R,S,T / U,V,W	Ground
ACG-20P5	M3	0.5	14 (2.5)	12 (4)
ACG-21P0	M3	0.5	14 (2.5)	12 (4)
ACG-22P0	M4	1.2	14 (2.5)	12 (4)
ACG-23P0	M4	1.2	14 (2.5)	12 (4)
ACG-25P0	M4	1.8	12 (4)	12 (4)
ACG-27P5	M4	1.4/1.5*	10 (6)	10 (6)
ACG-2010	M4	1.4/1.5*	10 (6)	10 (6)
ACG-2015	M5	2.5	6 (16)	6 (14)
ACG-2020	M5	2.5	4 (25)	6 (14)
ACG-40P5	M3.5	1.0	14 (2.5)	14 (2.5)
ACG-41P0	M3.5	1.0	14 (2.5)	14 (2.5)
ACG-42P0	M3.5	1.0	14 (2.5)	14 (2.5)
ACG-43P0	M3.5	1.0	14 (2.5)	14 (2.5)
ACG-45P0	M4	1.8	14 (2.5)	14 (2.5)
ACG-47P5	M4	1.4/1.8*	12/14 (4/2.5)*	12 (4)
ACG-4010	M4	1.4/1.8*	12 (4)	12 (4)
ACG-4015	M5	2.5	10 (6)	8 (8)
ACG-4020	M5	2.5	6/8 (16/10)*	8 (8)
ACG-4025	M5	2.5	6/8 (16/10)*	6 (14)
ACG-4030	M5	2.5	4/6 (25/16)*	6 (14)

* R, S, T value / U, V, W value
Use copper wires with 600V, 75°C (167°F) for power terminal wiring.

STEP 3 – KEYPAD NAVIGATION AND PARAMETER CHANGES

OPERATION GROUP

From the main screen (0.00), the UP and DOWN arrows will navigate through the Operation group. The Operation group contains many basic start up parameters for control and monitoring. See the list of Operation group parameters below.

Display	Operation Group	Display	Operation Group
0.00	Command Frequency	St3	Multi-Step Frequency 3
drC	Rotation Direction Select	St2	Multi-Step Frequency 2
nOn	Reserved	St1	Multi-Step Frequency 1
vOL	Output Voltage	Fr9	Frequency Source Reference
dCL	DC Voltage	drv	Command Source
rPm	Motor RPM	dEC	Deceleration Time 1
CUr	Output Current	ACC	Acceleration Time 1

Move up and down through the codes using the UP and DOWN arrow keys.

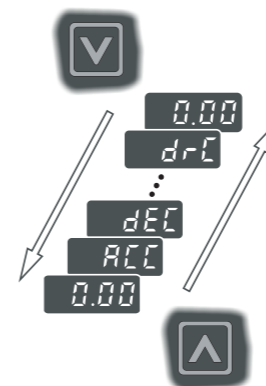

PARAMETER GROUPS

Pressing the MODE/SHIFT button will move through the different parameter groups, while the UP and DOWN arrows will navigate through the different parameter code numbers in the selected group.

Display	Parameter Group
dr	Drive
bA	Basic
Ad	Expanded
Cn	Control
In	Input Terminal Block
OU	Output Terminal Block
CM	Communication
AP	Application
Pr	Protection
M2	2nd Motor (In.65-69-> any one of these parameters is set to 26)

Any of the above parameter and monitor settings can be accessed by pressing the ENT key. Press the MODE key to move to the group you want. Press the ENT key again to save the entered value.

Press MODE with either arrow key to escape and make no change.

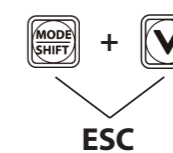

"rd" indicates reserved and cannot be selected.

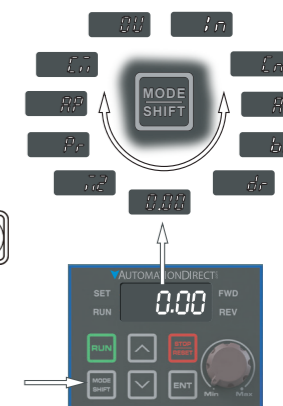

CHANGING ACCELERATION TIME EXAMPLE

- 1) Press UP arrow from the main display (0.00) until ACC is displayed.
- 2) Press ENT key one time to display the present value.
- 3) Use the UP and DOWN arrows to increase and decrease the value.
- 4) Use the MODE/SHIFT key to move the cursor over to select different digits.
- 5) Press the ENT key TWO TIMES once the desired value is set. This saves the change.
- 6) ACC will be displayed again indicating the parameter change has taken effect.



NOTE: Press the ENT key TWO times to save parameter changes! Press UP and DOWN arrows at the same time to escape parameter setting and make no changes.



NOTE: "rd" and "OL" can not be selected. "rd" indicates reserved, "OL" indicates set value repetition.

STEP 4 – CONNECT CONTROL WIRING

CONTROL WIRE SIZE

Terminal	Terminal Screw Size	Screw Torque (Nm)	Wire Size AWG (mm2) Bare Wire	Wire Size AWG (mm2) with Bootlace Ferrule
24/P1, P1-P5, CM	M2	2.2-2.5	18 (0.8)	20 (0.5)
A1/B1/C1/A2/C2/VR/V1/I2/AO/CM/Q1/EG/S+/S-	M2.6	4.0	18 (0.8)	20 (0.5)

*See User Manual for crimp terminal cable size and detail

3-Wire Control

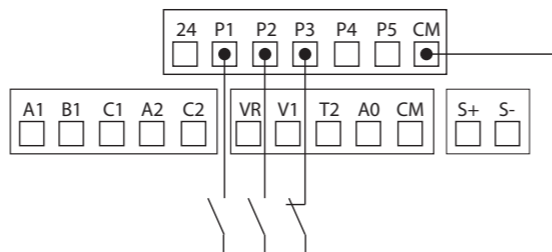

3-Wire control consists of momentary push buttons to run and stop the VFD. The Forward and Reverse buttons are Normally Open while the Stop button is Normally Closed.

drv=1 (FX/RX-1)
 P1(In.65)=1 (FWD Run, Fx)
 P2(In.66)=2 (REV Run, Rx)
 P3(In.67)=14 (3-Wire STOP)
 CM=Common

FREQUENCY REFERENCE WIRING

Speed Pot Wiring (0-10 VDC)

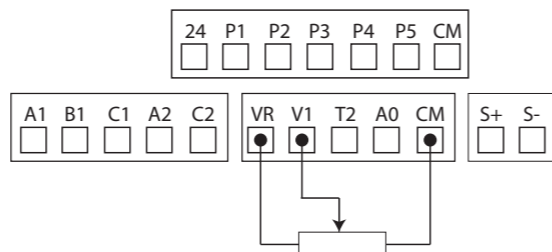

Controlling the VFD with an external speed potentiometer can be accomplished by setting Operation Menu parameter frq=2 and wiring according to the example below. For 0-10VDC signals from a PLC or controller, simply wire to V1 and CM.

VR = 10VDC
 V1 = Wiper
 CM = Common

PLC or Controller Wiring (4-20 mA)

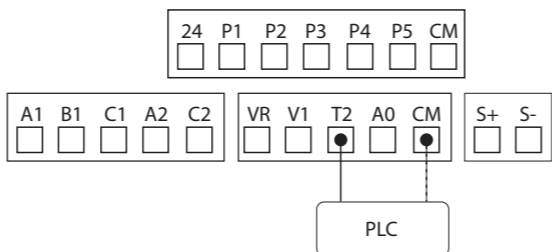

For speed control with a 4-20mA signal, set Operation Menu parameter frq=5.

I2 = + Signal
 CM = - Common

RUN COMMAND WIRING

2-Wire Control

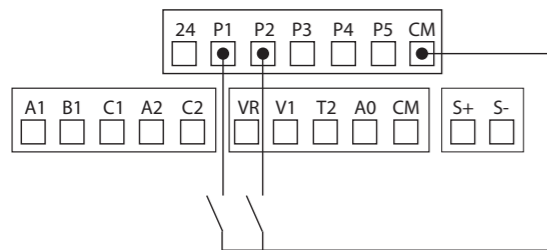

2-wire control consists of maintained run signals. This can be accomplished via toggle switches, relays, jumpers, etc. Default parameters support this operation.

Forward-Run/Reverse-Run
 drv=1 (FX/RX-1)
 P1(In.65)=1 (FWD Run, Fx)
 P2 (In.66)=2 (REV Run, Rx)
 CM=Common

Run/Direction
 drv=2 (FX/RX)
 P1(In.65)=1 Fx (1=Run,0=Stop)
 P2(In.66)=2 Rx (On-Reverse, Off-Forward)

I/O WIRING

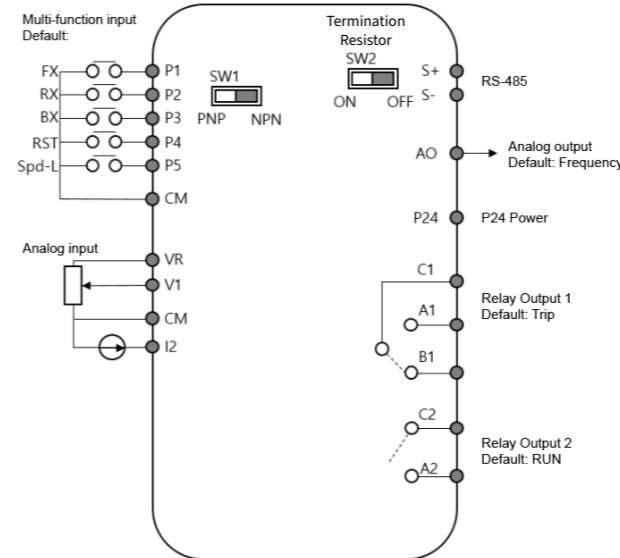

Digital Input Description

Terminal Labels	Description
P1-P5	Multi-Function Inputs with Default value and NPN sink mode wiring. Parameters In.65-In.69.
CM	Common terminal

Analog Input Description

Terminal Labels	Description
VR	Power Terminal for Setting Frequency 12V/100mA
V1	Frequency Setting (Voltage): -10V to 10V Parameters In.1-17
I2	Frequency Setting (Current): 4-20mA Parameters In.50-In.62

Output Description

Terminal Labels	Description
AO	Analog Output: 0-10V Use CM for Common. Parameter OU.1 Default: 0 (Frequency)
P24	External 24V Power
A1/C1/B1	Relay 1: Multi-Function Output Parameter OU.31 Default: 29 (TRIP)
A2/C2	Relay 2: Multi-Function Output Parameter OU.33 Default: 14 (RUN)

STEP 5 – BASIC SETUP PARAMETERS

REQUIRED MOTOR PARAMETERS

Set these motor parameters based on the nameplate.

Group	No	Description	Default	Set Options
dr	14	Motor Capacity	Model Dependent	Model Dependent
bA	11	Poles	4	2-12
bA	13	Motor Rated Current	Model Dependent	Model Dependent
bA	15	Motor Voltage	Model Dependent	Model Dependent

dr.14: HP to kW Conversion Chart (Parameter in kW)

HP	kW
1/4	0.2
1/2	0.4
1	0.75
1.5	1.1
2	1.5
3	2.2
5	3.7
7	5.5
10	7.5
15	11
20	15
25	18.5
30	22
40	30

Motor RPM to Poles Chart

RPM	3600	1800	1200
Poles	2	4	6

EXAMPLE: If actual motor RPM is 3450, set Motor Poles = 2. This is due to motor slip. In this example, the motor has 150 RPM of slip. (Slip=Synchronous speed - Rated Speed)

OPTIONAL PARAMETERS

- To automatically start after a power loss, set Ad.10=1. To enable power-on run, set the Operation Group drv parameter to Fx/Rx-1 or Fx/Rx-2. Run signal must stay present on power up.
- Enable phase loss protection by setting the virtual dipswitches in Pr.5 both to the up (top) position.
- Enable auto restart after a fault trip by setting the following...
 - » Pr.8 = 1
 - » Pr.9 = # of retry attempts

STEP 5 – BASIC SETUP PARAMETERS (CONT'D)

FAULT CODES

Keypad Display	Fault Name	Description
olt	Overload	Motor overload trip. Operates when Pr.20 > 0
ult	Underload	Motor underload trip. Operates when Pr.27 >0
oct	Over Current 1	Drive output current exceeds 200% of rated current
ovt	Over Voltage	Internal DC voltage exceeds the specified value
lvt	Low Voltage	Internal DC circuit voltage less than the limit
lv2	Low Voltage2	Internal DC circuit voltage less than limit during operation
gft	Ground Trip*	Grnd Flt trip occurs on drive output side and causes the current to exceed limit
eth	E-Thermal	Thermal load calculation determines motor overheating. Operates when Pr.40 >0
pot	Out Phase Open	Drive output phase(s) in open circuit condition. Operates when Pr.05 Bit 1=1
ipo	In Phase Open	3-phase drive input phase(s) in an open circuit condition. Operates when Pr.05 bit2=1
iol	Drive OLT	Overload and resultant overheating based on thermal limits
nmt	No Motor Trip	Motor is not connected during drive operation. Operates when Pr.31=1
oht	Over Heat	Drive heat sink temperature exceeds limit
oc2	Over Current2	DC circuit detection of excessive, short circuit current
ext	External Trip	External fault input signal is ON. Operates when In.65-69=4
bx	BX	Bx input signal is ON. Operates when In.65-69=5
hwt	H/W-Diag	Memory error detected (EEPROM)
ntc	NTC Open	Insulated Gate Bipolar Transistor (IGBT) Temperature sensor error
fan	Fan Trip	Cooling Fan malfunction. Operates when Pr.79 =0
pid	Pre-PID Fail	Pre-PID is operating and controlled variable PID feedback < set value
xbr	Ext-Brake	External Brake output signal is ON & VFD output current <Ad.41.Operates when OU.31/32= 35
lcr	Lost Command	Frequency or operation command error detected during drive operation Operates when Pr.12>0
iot	IO Board Trip	I/O board, communication card malfunction
hold		Error code continues for more than 5 sec
errc		
opt	Option Trip-1	Comm error is detected between the drive and the comm board. Operates when ACG-ETH is installed

*ACG drives rated for 4.0kW or less do not support the ground fault trip (gft) feature. Therefore, an over-current trip (oct) or over-voltage trip (ovt) may occur when there is a low-resistance ground fault.

See User Manual for other fault codes.

COMMONLY SET PARAMETERS

Pr.Code	Parameter Name	Setting Range	Units	Initial Value
Op Menu: 0.00	Command Frequency	Start Freq(dr.19) - Max Freq(dr.20)	Hz	0
Op Menu: ACC	Acceleration Time	0.0 - 600.0	sec	5.0
Op Menu: dEC	Deceleration Time	0.0 - 600.0	sec	10.0
Op Menu: drV	Command Source	0: Keypad 1: Fx/Rx -1 (Fwd/Rev Run) 2: Fx/Rx -2 (Run/Dir) 3: Int 485 4: Comm Card	-	1
Op Menu: Frq	Frequency Source Reference	0: Keypad-1 1: Keypad-2 2: V1 4: V2 5: I2 6: Int 485 8: Comm Card	-	0
Op Menu: drC	Rotation Direction	F: Forward Run r: Reverse Run		F
dr.9	Control Mode	0: V/F 2: Slip Compensation 4: IM Sensorless	-	0
dr.11	JOG Frequency	0.00, Start frequency-Maximum frequency	Hz	10.00
dr.12	Jog Run Acceleration Time	0.0 - 600.0	sec	20.0
dr.13	JOG Dec Time	0.0 - 600.0	sec	30.0
dr.18	Base Frequency	30.00 - 400.00	Hz	60.0
dr.19	Start Frequency	0.01 - 10.00	Hz	0.50
dr.20	Maximum Frequency	40.00~400.00(Hz) [V/F, SlipCompen] 40.00~120.00(Hz) [IMSensorless]	Hz	60.0
dr.93	Parameter Initialize (Reset to Defaults)	0: No 1: All Groups 2: dR group 3: bA group 4: Ad group 5: Cn group 6: In group 7: OU group 8: CM group 9: AP group 12: Pr group 13: M2 group 14: Run group	-	0
bA.19	AC Input Volt	170 - 480	V	220 / 480
Ad.9	Rotation Direction	0: None 1: Forward Prevent 2: Reverse Prevent	-	0
Ad.10	Power-on Run	0: No 1: Yes	-	0
In.1	Max Analog input Freq	Start freq [dr.19] - Max freq [dr.20] (Hz)	Hz	Max Freq
In.65	P1 Define	See Multifunction Discrete Input Selection Chart	-	1: Fx
In.66	P2 Define		-	2: Rx
In.67	P3 Define		-	3: Bx
In.68	P4 Define		-	4: Rst
In.69	P5 Define		-	5: Speed-L
OU.1	Analog output 1	See Analog Output (AO) Selection Chart	-	0: Freq
OU.31	Relay 1 (A1/B1/C1)	See Multifunction Relay Output Selection Chart	-	29: Trip
OU.33	Relay 2 (A2/C2)		-	14: Run

MULTIFUNCTION INPUT/OUTPUT SELECTION CHARTS

Multi-Function P1-P5 Discrete Input Selections	Multi-Function R1/R2 Relay Output Selections	Multi-Function AO Selections
0: None	0: None	0: Frequency
1: Fx	1: FDT-1	1: Output Current
2: Rx	2: FDT-2	2: Output Voltage
3: Reset (RST)	3: FDT-3	3: DCLink Voltage
4: Ext Trip	4: FDT-4	4: Torque
5: BX (Block)	5: Over Load	5: Output Power
6: JOG	6: IOL	6: Idse
7: Spd-L	7: Under Load	7: Iqse
8: Spd-M	8: Fan Warning	8: Target Freq
9: Spd-H	9: Stall	9: Ramp Freq
11: Xcel-L	10: Over Voltage	10: Speed Fdb
12: Xcel-M	11: Low Voltage	12: PID Ref Value
13: RUN Enable	12: Over Heat	13: PID Fdb Value
14: 3-wire	13: Lost Command	14: PID Output
15: 2nd Source	14: Run	15: Constant
16: Exchange PWR	15: Stop	
17: Speed Up	16: Steady	
18: Speed Down	17: Inverter Line	
20: U/D clear	18: Comm Line	
21: Analog Hold	19: Speed Search	
22: I Term Clear	21: Regeneration	
23: PID openloop	23: FDT-S (Z spd)	
24: P Gain2	22: Ready	
25: Xcel Stop	28: Timer Out	
26: 2nd Motor	29: Trip	
27: U/D Enable	31: DB Warn%ED	
33: Base Block	34: On/Off Control	
34: Pre Excite	35: BR Control	
38: Timer in	36: Reserved	
40: Dis Aux Ref	37: Fan Exchange	
46: FWD JOG	38: Fire Mode	
47: REV JOG	40: KEB Operation	
49: Xcel-H	41: Pre Overhead	
51: Fire Mode (set Ad.80=1)	42: Minor Fault	
52: KEB-1 Select	43: Torque Detect 1	
	44: Torque Detect 2	
	45: PID Sleep	