

CHAPTER 4: AC DRIVE PARAMETERS

TABLE OF CONTENTS

Chapter 4: AC Drive Parameters

AC Drive Parameters.	4-3
Bit Selection	4-3
Parameter Table Format Explanation.	4-3
Operation Parameter Group	4-5
DRIVE Parameter Group (dr)	4-7
BASIC Parameter group (bA)	4-10
ADVANCED Parameter group (Ad)	4-14
CONTROL Parameter Group (Cn).	4-18
INPUT Parameter Group (In)	4-21
OUTPUT Parameter Group (OU)	4-25
COMMUNICATION Parameter Group (CM)	4-29
APPLICATION Parameter Group (AP).	4-35
PROTECTION Parameter Group (Pr)	4-37
2nd MOTOR Parameter Group (M2)	4-41
IronHorse® ACG Drive Operation and Parameter Details	4-44
Chart Key	4-44
Learning Basic Features	4-45
Setting Frequency Reference	4-46
Setting Multi-step Frequency.	4-55
Command Source Configuration.	4-57
Forward or Reverse Run Prevention	4-61
Power-on Run	4-62
Reset and Restart	4-63
Setting Acceleration and Deceleration Times	4-64
Acc/Dec Pattern Configuration	4-68
Stopping the Acc/Dec Operation.	4-69
V/F (Voltage/Frequency) Control.	4-70
Torque Boost	4-73
Output Voltage Setting	4-75
Start Mode Setting	4-75
Stop Mode Setting.	4-77
Frequency Limit	4-80
2nd Operation Mode Setting.	4-82
Multi-function Input Terminal Control.	4-83
Fire Mode Operation	4-84
Learning Advanced Features	4-85
Operating with Auxiliary References	4-86
Jog operation	4-90
Up-down Operation.	4-91
Safe Operation Mode	4-94

<i>Dwell Operation</i>	4-95
<i>Slip Compensation Operation</i>	4-97
<i>PID Control</i>	4-98
<i>Auto Tuning</i>	4-104
<i>Sensorless Vector Control for Induction Motors</i>	4-106
<i>Kinetic Energy Buffering Operation</i>	4-111
<i>Energy Saving Operation</i>	4-114
<i>Speed Search Operation</i>	4-115
<i>Auto Restart Settings</i>	4-119
<i>Operational Noise Settings (carrier frequency settings)</i>	4-120
<i>2nd Motor Operation</i>	4-121
<i>Supply Power Transition</i>	4-122
<i>Cooling Fan Control</i>	4-123
<i>Input Power Frequency and Voltage Settings</i>	4-124
<i>Parameter Save</i>	4-125
<i>Parameter Initialization (Reset to Defaults)</i>	4-125
<i>Parameter Lock</i>	4-126
<i>Changed Parameter Display</i>	4-126
<i>Multi-function IO Timer Settings</i>	4-127
<i>Brake Control</i>	4-128
<i>Multi-Function Output Relay On/Off Control</i>	4-129
<i>Press Regeneration Prevention</i>	4-129
<i>Analog Output</i>	4-130
<i>Digital Output</i>	4-133
<i>Base Block</i>	4-139
Learning Protection Features	4-140
<i>Motor Protection</i>	4-140
<i>Drive and Sequence Protection</i>	4-146
<i>Dynamic Braking</i>	4-149
<i>Under load Fault Trip and Warning</i>	4-151
<i>Torque Detection Protection Action</i>	4-156
<i>Fault/Warning List</i>	4-158

AC DRIVE PARAMETERS

This chapter covers all the parameters available for use with the Ironhorse ACG series drives. The "Parameter Summary" section provides a table of all the parameters with basic information. The subsequent chapter sections provide explanations about each parameter and how they interact with other parameters.

Set the parameters required according to the following chapter. If a set value input is out of range or not allowed, the following messages can be shown on the keypad display. In these cases, the parameter value will not be accepted with the [ENT] key.

- **rd**: Set value not allocated (reserved)
- **OL**: Set value repetition (multi-function input, PID reference, PID feedback related)
- **no**: Set value not allowed (select value, V0, I2)

BIT SELECTION

Bit level selections are displayed as follows:

Drive Keypad

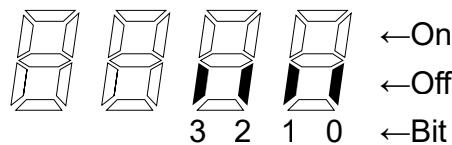

Use the left/right arrows to move bits. Use up/down arrows to toggle bits on/off.

PARAMETER TABLE FORMAT EXPLANATION

The ACG drive has 12 parameter groups containing over 400 parameters.

Parameter Group								
Pr. Code	Name	Setting Range	Initial Value	Run R/W	Parameter Dependency	Compatible Control Mode	Comm. Address (Hex)	Ref.

TABLE LEGEND

- **Code** – Parameter display group and number shown on the drive keypad
- **Name** – Parameter description
- **Setting Range** – Range of parameter settings, including units if applicable
- **Initial Value** – Parameter default setting
- **Run R/W**
 - » ♦R/W – Parameter Write-enabled during Operation (Run mode)
 - » R/W – Parameter Write-enabled when stopped
 - » Parameter Read Only
- **Parameter Dependency** – Indicates a parameter is available only when this criteria is met. If blank, the parameter has no additional dependency.
- **Compatible Control Mode** – Indicates a parameter is available in these control modes only. Control mode is set by Parameter dr.9.
 - » "v" – v/f (dr.9 = 0)
 - » "s" – slip compensation (dr.9 = 2)
 - » "i" – IM Sensorless (dr.9=4)
- **Comm. Address** – Hexadecimal parameter address for serial communications.
- **Ref.** – Page reference and link to parameter details.

Parameter Group Summary		
Parameter Group Display Code	Description	Parameter Pr. Group Dependency
<p>Drive Keypad LED</p> 		
n/a	Operation (SPS)	
dr	Drive	
bA	Basic	
Ad	Advanced	
Cn	Control	
In	Inputs	
OU	Outputs	
CM	Communication	
AP	Application	
Pr	Protection	
M2*	2nd Motor	* In.65–In.69→ any one of these parameters is set to 26

OPERATION PARAMETER GROUP

The Operation Group (SPS) is accessed by pressing the up or down arrow on the keypad. The other parameter groups are accessed by pressing the Mode key.

See "Table Legend" on page 4-3 for details on each column in the table below.

Operation Parameter Group									
Pr. Code	Name	Setting Range	Initial Value	Run R/W	Parameter Dependency	Compatible Control Mode	Comm. Address (Hex)	Ref.	
0.00	Target frequency	0–Maximum frequency(Hz)	0.00	◆R/W	–	v, s, i	0h1D00	3–5	
ACC	Acceleration time	0.0–600.0s	5.0	◆R/W	–	v, s, i	0h1D01	4–62	
dEC	Deceleration time	0.0–600.0s	10.0	◆R/W	–	v, s, i	0h1D02	4–62	
drv	Command source	0	Keypad	1: Fx/Rx–1 (Fwd Run/Rev Run)	R/W	–	v, s, i	0h1D03	4–55
		1	Fx/Rx–1 (Fwd Run/Rev Run)						
		2	Fx/Rx–2 (Run/Direction)						
		3	Int 485						
		4	Fieldbus (Ethernet)[1]						
Frq	Frequency reference source	0	Keypad–1: Change+Enter	0: Keypad–1	R/W	–	v, s, i	0h1D04	4–44
		1	Keypad–2: Instant change						
		2	V1: Voltage Analog Input						
		4	V0: Built-in Potentiometer dial						
		5	I2: Current Analog Input						
		6	Int 485						
		8	Fieldbus (Ethernet)						
St1	Multi-step speed frequency 1	0.00–Maximum frequency(Hz)	10.00	◆R/W	–	v, s, i	0h1D05	4–53	
St2	Multi-step speed frequency 2	0.00–Maximum frequency(Hz)	20.00	◆R/W	–	v, s, i	0h1D06	4–53	
St3	Multi-step speed frequency 3	0.00–Maximum frequency(Hz)	30.00	◆R/W	–	v, s, i	0h1D07	4–53	
CUr	Output current	–	–	Read Only	–	v, s, i	0h1D08	3–15	
Rpm	Motor revolutions per minute	–	–	Read Only	–	v, s, i	0h1D09	–	
dCL	Drive direct current voltage	–	–	Read Only	–	v, s, i	0h1D0A	3–15	
vOL	Drive output voltage (dr.81 User Selectable)	–	–	Read Only	–	v, s, i	0h1D0B	3–15	
nOn	Out of order signal	–	–	–	–	v, s, i	0h1D0C	–	

Operation Parameter Group									
Pr. Code	Name	Setting Range		Initial Value	Run R/W	Parameter Dependency	Compatible Control Mode	Comm. Address (Hex)	Ref.
drC	Select rotation direction	F	Forward run	F	◆R/W	–	v, s, i	0h1D0D	–
		r	Reverse run						

DRIVE PARAMETER GROUP (dr)

The DRIVE parameter group is labeled using dr.

See "Table Legend" on page 4-3 for details on each column in the table below.

Drive Parameter Group (dr)									
Pr. Code	Name	Setting Range		Initial Value	Run R/W	Parameter Dependency	Compatible Control Mode	Comm. Address (Hex)	Ref.
dr.0	Jump Code	1-99		9	◆R/W	–	v, s, i	–	3-6
dr.9	Control mode	0	V/F	0: V/F	R/W	–	v, s, i	0h1109	4-68
		2	Slip Compen						4-95
		4	IM Sensorless						4-104
dr.11	Jog frequency	0.00, Start frequency–Maximum frequency(Hz)		10.00	◆R/W	–	v, s, i	0h110B	4-88
dr.12	Jog run acceleration time	0.0–600.0s		20.0	◆R/W	–	v, s, i	0h110C	4-88
dr.13	Jog run deceleration time	0.0–600.0s		30.0	◆R/W	–	v, s, i	0h110D	4-88
dr.14	Motor capacity	0	0.2 kW (1/4 hp)	Varies by Drive capacity	R/W	–	v, s, i	0h110E	4-102
		1	0.4 kW (1/2 hp)						
		2	0.75 kW (1 hp)						
		3	1.1 kW (1.5 hp)						
		4	1.5 kW (2 hp)						
		5	2.2 kW (3 hp)						
		6	3.0 kW (4 hp)						
		7	3.7 kW (4 hp)						
		8	4.0 kW (5 hp)						
		9	5.5 kW (7.5 hp)						
		10	7.5 kW (10 hp)						
		11	11.0 kW (15 hp)						
		12	15.0 kW (20 hp)						
		13	18.5 kW (25 hp)						
		14	22.0 kW (30 hp)						
15	30.0 kW (40 hp)								
dr.15	Torque boost options	0	Manual	0: Manual	R/W	–	v, s	0h110F	–
		1	Auto1						
dr.16	Forward Torque boost	0.0–15.0%		2.0	R/W	–	v, s	0h1110	4-71
dr.17	Reverse Torque boost	0.0–15.0%		2.0	R/W	–	v, s	0h1111	4-71
dr.18	Base frequency	40.00–400.00 Hz [V/F, Slip Compen] 40.00–120.00 Hz [IM Sensorless]		60.00	R/W	–	v, s, i	0h1112	4-68
dr.19	Start frequency	0.01–10.00Hz		0.50	R/W	–	v, s, i	0h1113	4-68
dr.20	Maximum frequency	40.00–400.00 Hz [V/F, Slip Compen] 40.00–120.00 Hz [IM Sensorless]		60.00	R/W	–	v, s, i	0h1114	4-78

Drive Parameter Group (dr)								
Pr. Code	Name	Setting Range	Initial Value	Run R/W	Parameter Dependency	Compatible Control Mode	Comm. Address (Hex)	Ref.
dr.26	Auto torque boost filter gain	1–1000	2.0	◆R/W	dR.15=1	v, s	0h111A	4–72
dr.27	Auto torque boost monitoring gain	0.0–300.0%	50.0	◆R/W	dR.15=1	v, s	0h111B	4–72
dr.28	Auto torque boost regeneration	0.0–300.0%	50.0	◆R/W	dR.15=1	v, s	0h111C	4–72
dr.80	Select ranges at power input	Select ranges drive displays at power input		0: Run frequency	◆R/W	v, s, i	0h1150	–
		0	Run frequency					
		1	Acceleration time					
		2	Deceleration time					
		3	Command source					
		4	Frequency reference source					
		5	Multi-step speed frequency1					
		6	Multi-step speed frequency2					
		7	Multi-step speed frequency3					
		8	Output current					
		9	Motor RPM					
		10	Drive DC voltage					
		11	User select signal (dr.81)					
		12	Currently out of order					
		13	Select run direction					
		14	Output current2					
		15	Motor RPM2					
16	Drive DC voltage2							
17	User select signal2 (dr.81)							
dr.81	Select monitor code	User selected display value for Operation (SPS) Menu		0: Output voltage	◆R/W	v, s, i	0h1151	3–15
		0	Output voltage(V)					
		1	Output electric power (kW)					
		2	Torque (kg f*m)					
		3	PID feedback monitor					
dr.87	Drive Firmware (datafile) version					v, s, i	0h0301	
dr.89	Display changed parameter	0	View All	0: View All	◆R/W	v, s, i	0h03E3	4–124
		1	View Changed					
dr.90	Reserved	–	–	–	–	–	–	–

Drive Parameter Group (dr)									
Pr. Code	Name	Setting Range		Initial Value	Run R/W	Parameter Dependency	Compatible Control Mode	Comm. Address (Hex)	Ref.
dr.91	Smart copy	0	None	0: None	R/W		v, s, i	0h115B	–
		1	SmartDownlaod						
		3	SmartUpLoadd						
		4	RemoteUpLoad						
		5	RemoteDownload						
dr.92	Parameter save	0	None	0: None	R/W		v, s, i	no address	4-123
		1	Parameter Save						
dr.93	Parameter initialization	0	No	0: No	R/W		v, s, i	0h115D	4-123
		1	All Grp						
		2	dr Grp						
		3	bA Grp						
		4	Ad Grp						
		5	Cn Grp						
		6	In Grp						
		7	OU Grp						
		8	CM Grp						
		9	AP Grp						
		12	Pr Grp						
		13	M2 Grp						
14	Operation Grp								
dr.94	Password registration	0–9999		–	◆R/W		v, s, i	0h115E	4-124
dr.95	Parameter lock settings	0–9999		–	◆R/W		v, s, i	0h115F	4-124
dr.97	Software version	–		–	Read Only		v, s, i	0h1161	–
dr.98	Display I/O (Comm) board version	–		–	Read Only	–	v, s, i	0h1162	–

BASIC PARAMETER GROUP (bA)

The BASIC parameter group is labeled using bA.

See "Table Legend" on page 4-3 for details on each column in the table below.

BASIC Parameter group (bA)								
Pr. Code	Name	Setting Range	Initial Value	Run R/W	Parameter Dependency	Compatible Control Mode	Comm. Address (Hex)	Ref.
bA.0	Jump Code	1-99	20	◆R/W	–	v, s, i	–	3-6
bA.1	Auxiliary reference source	0	None	0: None	R/W	–	v, s, i	0h1201
		1	V1: Analog Voltage Input					
		3	V0: Built-in Potentiometer dial					
		4	I2: Analog Current Input					
bA.2	Auxiliary command calculation type	0	M+(G*A)	0: M+(G*A)	R/W	bA.1≠0	v, s, i	0h1202
		1	Mx (G*A)					
		2	M/(G*A)					
		3	M+[M*(G*A)]					
		4	M+G*2(A-50%)					
		5	Mx[G*2(A-50%)					
		6	M/[G*2(A-50%)]					
		7	M+M*G*2 (A-50%)					
bA.3	Auxiliary command gain	-200.0-200.0%	100.0	◆R/W	bA.1≠0	v, s, i	0h1203	4-84
bA.4	2nd command source	0	Keypad	1: Fx/Rx-1 (Fwd Run/Rev Run)	R/W	–	v, s, i	0h1204
		1	Fx/Rx-1 (Fwd Run/Rev Run)					
		2	Fx/Rx-2 (Run/Direction)					
		3	Int 485					
		4	Fieldbus (Ethernet)					
bA.5	2nd frequency source	0	Keypad-1	0: Keypad-1	◆R/W	–	v, s, i	0h1205
		1	Keypad-2					
		2	V1					
		4	V0					
		5	I2					
		6	Int 485					
		8	Fieldbus (Ethernet)					
bA.7	V/F pattern options	0	Linear	0: Linear	R/W	–	v, s	0h1207
		1	Square					
		2	User V/F					
		3	Square 2					
bA.8	Acc/dec standard frequency	0	Max Freq	0: Max Freq	R/W	–	v, s, i	0h1208
		1	Delta Freq					
bA.9	Time scale settings	0	0.01 sec	1: 0.1 sec	R/W	–	v, s, i	0h1209
		1	0.1 sec					
		2	1 sec					

BASIC Parameter group (bA)									
Pr. Code	Name	Setting Range		Initial Value	Run R/W	Parameter Dependency	Compatible Control Mode	Comm. Address (Hex)	Ref.
bA.10	Input power frequency	0	60Hz	0: 60Hz	R/W	–	v, s, i	0h120A	4–122
		1	50Hz						
bA.11	Number of motor poles	2–48		Dependent on motor setting	R/W	–	v, s, i	0h120B	4–95
bA.12	Rated slip speed	0–3000(Rpm)		Dependent on motor setting	R/W	–	v, s, i	0h120C	4–95
bA.13	Motor rated current	1.0–1000.0A		Dependent on motor setting	R/W	–	v, s, i	0h120D	4–95
bA.14	Motor no load current	0.0–1000.0A		Dependent on motor setting	R/W	–	v, s, i	0h120E	4–95
bA.15	Motor rated voltage	0, 100–480V		0	R/W	–	v, s, i	0h120F	4–73
bA.16	Motor efficiency	64–100%		Dependent on motor setting	R/W	–	v, s, i	0h1210	4–95
bA.17	Load inertia rate	0–8		0	R/W	–	v, s, i	0h1211	4–95
bA.18	Trim power display	70–130%		100	◆R/W	–	v, s, i	0h1212	–
bA.19	Input power voltage	170–480V		220/380	◆R/W	–	v, s, i	0h1213	4–122
bA.20	Auto Tuning	0	None	0: None	R/W	–	i	–	4–102
		1	All (Rotation type)						
		2	ALL (Static type)						
		3	Rs+Lsigma (Rotation type)						
		6	Tr (Static type)						
bA.21	Stator resistance	Dependent on motor setting		Dependent on motor setting	R/W	–	i	–	4–102
bA.22	Leakage inductance	–		Dependent on motor setting	R/W	–	i	–	4–102
bA.23	Stator inductance	–		Dependent on motor setting	R/W	–	i	–	4–102
bA.24	Rotor time constant	25–5000(ms)		Dependent on motor setting	R/W	dr.9=4 IM Sensorless	i	–	4–102
bA.41	User frequency1	0.00–Maximum frequency(Hz)		15.00	R/W	bA.7 or m2.25=2	v, s	0h1229	4–70
bA.42	User voltage1	0–100%		25	R/W	bA.7 or m2.25=2	v, s	0h122A	4–70
bA.43	User frequency2	0.00–0.00– Maximum frequency(Hz)		30.00	R/W	bA.7 or m2.25=2	v, s	0h122B	4–70
bA.44	User voltage2	0–100%		50	R/W	bA.7 or m2.25=2	v, s	0h122C	4–70

BASIC Parameter group (bA)								
Pr. Code	Name	Setting Range	Initial Value	Run R/W	Parameter Dependency	Compatible Control Mode	Comm. Address (Hex)	Ref.
bA.45	User frequency3	0.00–Maximum frequency(Hz)	45.00	R/W	bA.7 or m2.25=2	v, s	0h122D	4–70
bA.46	User voltage3	0–100%	75	R/W	bA.7 or m2.25=2	v, s	0h122E	4–70
bA.47	User frequency4	0.00–Maximum frequency(Hz)	Maximum frequency	R/W	bA.7 or m2.25=2	v, s	0h122F	4–70
bA.48	User voltage4	0–100%	100	R/W	bA.7 or m2.25=2	v, s	0h1230	4–70
bA.53	Multi-step speed frequency4	0.00–Maximum frequency(Hz)	40.00	◆R/W	In.65–69=Spd–L/M/H	v, s, i	0h1235	4–53
bA.54	Multi-step speed frequency5	0.00–Maximum frequency(Hz)	50.00	◆R/W	In.65–69=Spd–L/M/H	v, s, i	0h1236	4–53
bA.55	Multi-step speed frequency6	0.00–Maximum frequency(Hz)	Maximum frequency	◆R/W	In.65–69=Spd–L/M/H	v, s, i	0h1237	4–53
bA.56	Multi-step speed frequency7	0.00–Maximum frequency(Hz)	Maximum frequency	◆R/W	In.65–69=Spd–L/M/H	v, s, i	0h1238	4–53
bA.70	Multi-step acceleration time1	0.0–600.0s	20.0	◆R/W	–	v, s, i	0h1246	4–63
bA.71	Multi-step deceleration time1	0.0–600.0s	20.0	◆R/W	–	v, s, i	0h1247	4–63
bA.72	Multi-step acceleration time2	0.0–600.0s	30.0	◆R/W	In.65–69=Xcel–L/M/H	v, s, i	0h1248	4–63
bA.73	Multi-step deceleration time2	0.0–600.0s	30.0	◆R/W	In.65–69=Xcel–L/M/H	v, s, i	0h1249	4–63
bA.74	Multi-step acceleration time3	0.0–600.0s	40.0	◆R/W	In.65–69=Xcel–L/M/H	v, s, i	0h124A	4–63
bA.75	Multi-step deceleration time3	0.0–600.0s	40.0	◆R/W	In.65–69=Xcel–L/M/H	v, s, i	0h124B	4–63
bA.76	Multi-step acceleration time4	0.0–600.0s	50.0	◆R/W	In.65–69=Xcel–L/M/H	v, s, i	0h124C	4–63
bA.77	Multi-step deceleration time4	0.0–600.0s	50.0	◆R/W	In.65–69=Xcel–L/M/H	v, s, i	0h124D	4–63
bA.78	Multi-step acceleration time5	0.0–600.0s	40.0	◆R/W	In.65–69=Xcel–L/M/H	v, s, i	0h124E	4–63
bA.79	Multi-step deceleration time5	0.0–600.0s	40.0	◆R/W	In.65–69=Xcel–L/M/H	v, s, i	0h124F	4–63
bA.80	Multi-step acceleration time6	0.0–600.0s	30.0	◆R/W	In.65–69=Xcel–L/M/H	v, s, i	0h1250	4–63

BASIC Parameter group (bA)								
Pr. Code	Name	Setting Range	Initial Value	Run R/W	Parameter Dependency	Compatible Control Mode	Comm. Address (Hex)	Ref.
bA.81	Multi-step deceleration time6	0.0–600.0s	30.0	◆R/W	In.65–69=Xcel–L/M/H	v, s, i	0h1251	4–63
bA.82	Multi-step acceleration time7	0.0–600.0s	20.0	◆R/W	In.65–69=Xcel–L/M/H	v, s, i	0h1252	4–63
bA.83	Multi-step deceleration time7	0.0–600.0s	20.0	◆R/W	In.65–69=Xcel–L/M/H	v, s, i	0h1253	4–63

ADVANCED PARAMETER GROUP (Ad)

The ADVANCED parameter group is labeled using *Ad*.

See "Table Legend" on page 4-3 for details on each column in the table below.

ADVANCED Parameter Group (Ad)									
Pr. Code	Name	Setting Range		Initial Value	Run R/W	Parameter Dependency	Compatible Control Mode	Comm. Address (Hex)	Ref.
Ad.0	Jump Code	1-99		24	◆R/W	–	v, s, i	–	3-6
Ad.1	Acceleration pattern	0	Linear	0: Linear	R/W	–	v, s, i	0h1301	4-66
		1	S-curve						
Ad.2	Deceleration pattern	0	Linear	0: Linear	R/W	–	v, s, i	0h1302	4-66
		1	S-curve						
Ad.3	S-curve acceleration start point gradient	1-100%		40	R/W	Ad.1=1	v, s, i	0h1303	4-66
Ad.4	S-curve acceleration end point gradient	1-100%		40	R/W	Ad.1=1	v, s, i	0h1304	4-66
Ad.5	S-curve deceleration start point gradient	1-100%		40	R/W	Ad.2=1	v, s, i	0h1305	4-66
Ad.6	S-curve deceleration end point gradient	1-100%		40	R/W	Ad.2=1	v, s, i	0h1306	4-66
Ad.7	Start Mode	0	Acc	0: Acc	R/W	–	v, s, i	0h1307	4-73
		1	DC-Start						
Ad.8	Stop Mode	0	Dec	0: Dec	R/W	–	v, s, i	0h1308	4-75
		1	DC-Brake						
		2	Free-Run						
		4	Power Braking						
Ad.9	Selection of prohibited rotation direction	0	None	0: None	R/W	–	v, s, i	0h1309	4-59
		1	Forward Prevent						
		2	Reverse Prevent						
Ad.10	Starting with power on	0	No	0: No	◆R/W	–	v, s, i	0h130A	4-60
		1	Yes						
Ad.12	DC braking time at startup	0.00-60.00s		0.00	R/W	Ad.7=1	v, s	0h130C	4-73
Ad.13	Amount of applied DC	0-Rated Current of Drive/ Rated Current of Motor x 100 (%)		50	R/W	–	v, s	0h130D	4-73
Ad.14	Output blocking time before DC braking	0.00- 60.00s		0.10	R/W	Ad.8=1	v, s, i	0h130E	4-75
Ad.15	DC braking time	0.00- 60.00s		1.00	R/W	Ad.8=1	v, s, i	0h130F	4-75
Ad.16	DC braking rate	0-Rated Current of Drive/ Rated Current of Motor x 100 (%)		50	R/W	Ad.8=1	v, s, i	0h1310	4-75
Ad.17	DC braking frequency	Start frequency-60 Hz		5.00	R/W	Ad.8=1	v, s, i	0h1311	4-75
Ad.20	Dwell frequency on acceleration	Start frequency-Maximum frequency(Hz)		5.00	R/W	–	v, s, i	0h1314	4-93

ADVANCED Parameter Group (Ad)									
Pr. Code	Name	Setting Range		Initial Value	Run R/W	Parameter Dependency	Compatible Control Mode	Comm. Address (Hex)	Ref.
Ad.21	Dwell operation time on acceleration	0.0–60.0s		0.0	R/W	–	v, s, i	0h1315	4–93
Ad.22	Dwell frequency on deceleration	Start frequency–Maximum frequency(Hz)		5.00	R/W	–	v, s, i	0h1316	4–93
Ad.23	Dwell operation time on deceleration	0.0–60.0s		0.0	R/W	–	v, s, i	0h1317	4–93
Ad.24	Frequency limit	0	No	0: No	R/W	–	v, s, i	0h1318	4–78
		1	Yes						
Ad.25	Frequency lower limit value	0.00–Upper limit frequency (Hz)		0.50	◆R/W	Ad.24=1	v, s, i	0h1319	4–78
Ad.26	Frequency upper limit value	Lower limit frequency–Maximum frequency (Hz)		maximum frequency	R/W	Ad.24=1	v, s, i	0h131A	4–78
Ad.27	Frequency jump	0	No	0: No	R/W	–	v, s, i	0h131B	4–79
		1	Yes						
Ad.28	Jump frequency lower limit1	0.00–Jump frequency upper limit1 (Hz)		10.00	◆R/W	Ad.27=1	v, s, i	0h131C	4–79
Ad.29	Jump frequency upper limit1	Jump frequency lower limit1–Maximum frequency (Hz)		15.00	◆R/W	Ad.27=1	v, s, i	0h131D	4–79
Ad.30	Jump frequency lower limit2	0.00–Jump frequency upper limit2 (Hz)		20.00	◆R/W	Ad.27=1	v, s, i	0h131E	4–79
Ad.31	Jump frequency upper limit2	Jump frequency lower limit2–Maximum frequency(Hz)		25.00	◆R/W	Ad.27=1	v, s, i	0h131F	4–79
Ad.32	Jump frequency lower limit3	0.00–Jump frequency upper limit3 (Hz)		30.00	◆R/W	Ad.27=1	v, s, i	0h1320	4–79
Ad.33	Jump frequency upper limit3	Jump frequency lower limit3–Maximum frequency (Hz)		35.00	◆R/W	Ad.27=1	v, s, i	0h1321	4–79
Ad.41	Brake release current	0.0–180.0%		50.0	◆R/W	OU.31 or OU.33 = 35	v, s, i	0h1329	4–126
Ad.42	Brake release delay time	0.00–10.00s		1.00	R/W	OU.31 or OU.33 = 35	v, s, i	0h132A	4–126
Ad.44	Brake release Forward frequency	0.00–Maximum frequency(Hz)		1.00	R/W	OU.31 or OU.33 = 35	v, s, i	0h132C	4–126
Ad.45	Brake release Reverse frequency	0.00–Maximum frequency(Hz)		1.00	R/W	OU.31 or OU.33 = 35	v, s, i	0h132D	4–126
Ad.46	Brake engage delay time	0.00–10.00s		1.00	R/W	OU.31 or OU.33 = 35	v, s, i	0h132E	4–126
Ad.47	Brake engage frequency	0.00–Maximum frequency(Hz)		2.00	R/W	OU.31 or OU.33 = 35	v, s, i	0h132F	4–126
Ad.50	Energy saving operation	0	None	0: None	R/W	–	v, s	0h1332	4–112
		1	Manual						
		2	Auto						
Ad.51	Energy saving level	0–30%		0	◆R/W	Ad.50≠0	v, s	0h1333	4–112
Ad.60	Acc/Dec time switch frequency	0.00–Maximum frequency(Hz)		0.00	R/W	–	v, s, i	0h133C	4–64

ADVANCED Parameter Group (Ad)									
Pr. Code	Name	Setting Range	Initial Value	Run R/W	Parameter Dependency	Compatible Control Mode	Comm. Address (Hex)	Ref.	
Ad.61	Rotation count speed gain (RPM display)	0.1–6000.0%	100.0	◆R/W	–	v, s, i	0h133D	4–137	
Ad.62	Reserved	–	–	–	–	–	–	–	
Ad.63	Reserved	–	–	–	–	–	–	–	
Ad.64	Cooling fan control	0	During Run	0: During Run	◆R/W	–	v, s, i	0h1340	4–122
		1	Always ON						
		2	Temp Control						
Ad.65	Up/down operation frequency save	0	No	0: No	◆R/W	–	v, s, i	0h1341	4–89
		1	Yes						
Ad.66	Output contact On/Off control options	0	None	0: None	R/W	–	v, s, i	0h1342	4–127
		1	V1						
		3	V0						
		4	I2						
Ad.67	Output contact On level	Output contact off level–100.00%	90.00	R/W	–	v, s, i	0h1343	4–127	
Ad.68	Output contact Off level	–100.00–output contact on level (%)	10.00	R/W	–	v, s, i	0h1344	4–127	
Ad.70	Safe operation selection	0	Always Enable	0: Always Enable	R/W	–	v, s, i	0h1346	4–92
		1	DI Dependent						
Ad.71	Safe operation stop options	0	Free–Run	0: Free–Run	R/W	Ad.70=1	v, s, i	0h1347	4–92
		1	Q–Stop						
		2	Q–Stop Resume						
Ad.72	Safe operation deceleration time	0.0–600.0s	5.0	◆R/W	Ad.70=1	v, s, i	0h1348	4–92	
Ad.74	Selection of regeneration evasion function for press	0	No	0: No	R/W	–	v, s, i	0h134A	4–127
		1	Yes						
Ad.75	Voltage level of regeneration evasion motion for press	230V : 300–400V	350	R/W	–	v, s, i	0h134B	4–127	
		460V : 600–800V	700						
Ad.76	Compensation frequency limit of regeneration evasion for press	0.00– 10.00Hz	1.00	R/W	Ad.74=1	v, s, i	0h134C	4–127	
Ad.77	Regeneration evasion for press P gain	0.0– 100.0%	50.0	◆R/W	Ad.74=1	v, s, i	0h134D	4–127	
Ad.78	Regeneration evasion for press I gain	20–30000(ms)	500	◆R/W	Ad.74=1	v, s, i	0h134E	4–127	
Ad.79	Dynamic Brake (DB) Unit turn on voltage level	230V: 350–400V	390V	R/W	–	v, s, i	0h134F	4–147	
		460V: 600–800V	780V						

ADVANCED Parameter Group (Ad)									
Pr. Code	Name	Setting Range		Initial Value	Run R/W	Parameter Dependency	Compatible Control Mode	Comm. Address (Hex)	Ref.
Ad.80	Fire mode selection	0	None	0: None	R/W	–	v, s, i	0h1350	4–82
		1	Fire Mode						
		2	Fire Mode Test						
Ad.81	Fire mode frequency	Start frequency–Maximum frequency (Hz)		60.00	R/W	Ad.80≠0	v, s, i	0h1351	4–82
Ad.82	Fire mode direction	0	Forward	0: Forward	R/W	Ad.80≠0	v, s, i	0h1352	4–82
		1	Reverse						
Ad.83	Fire Mode Count	Can not be modified		–	Read Only	Ad.80≠0	v, s, i	–	4–82
Ad.85	Up–down mode selection	0	U/D Normal	0: U/D Normal	R/W	–	v, s, i	0h1355	4–89
		1	U/D Step						
		2	U/D Step+ Norm						
Ad.86	Up–down step frequency	0–maximum frequency (Hz)		0	◆R/W	–	v, s, i	0h1356	4–89

CONTROL PARAMETER GROUP (Cn)

The CONTROL parameter group is labeled using Cn.

See "Table Legend" on page 4-3 for details on each column in the table below.

CONTROL Parameter Group (Cn)									
Pr. Code	Name	Setting Range		Initial Value	Run R/W	Parameter Dependency	Compatible Control Mode	Comm. Address (Hex)	Ref.
Cn.0	Jump Code	1-99		4	◆R/W	–	v, s, i	–	3-6
Cn.4	Carrier frequency	Heavy load (HD)	V/F: 1.0-15.0 (kHz) IM: 2.0-15.0 (kHz)	3.0	R/W	–	v, s, i	0h1404	4-118
		Normal load (ND)	V/F: 1.0-5.0 (kHz) IM: 2.0-5.0 (kHz)	2.0					
Cn.5	Switching mode	0	Normal PWM	0: Normal PWM	R/W	–	v, s, i	0h1405	4-118
Cn.9	Initial excitation time	0.00-60.00s		1.00	R/W	–	i	0h1409	4-106
Cn.10	Initial excitation amount	100.0-300.0%		100.0	R/W	–	i	0h140A	4-106
Cn.11	Continued operation duration	0.00-60.00s		0.00	R/W	–	i	0h140B	4-106
Cn.21	Low-speed torque compensation gain	50-300%		Dependent on motor setting	R/W	–	i	0h1415	4-106
Cn.22	Output torque compensation gain	50-300%		Dependent on motor setting	R/W	–	i	0h1416	4-106
Cn.23	Speed deviation compensation gain	50-300%		Dependent on motor setting	R/W	–	i	0h1417	4-106
Cn.24	Main compensation of speed deviation	50-300%		Dependent on motor setting	R/W	–	i	0h1418	4-106
Cn.29	No load speed deviation compensation gain	0.50-2.00		1.06	◆R/W	–	i	0h141D	4-106
Cn.30	Speed response adjustment gain	2.0-10.0		4	◆R/W	–	i	0h141E	4-106

CONTROL Parameter Group (Cn)									
Pr. Code	Name	Setting Range		Initial Value	Run R/W	Parameter Dependency	Compatible Control Mode	Comm. Address (Hex)	Ref.
Cn.53	Torque limit setting options	0	Keypad-1: Change+Enter	0: Keypad-1	R/W	-	i	0h1435	4-106
		1	Keypad-2: Instant change						
		2	V1: Voltage Analog Input						
		4	V0: Built-in Potentiometer dial						
		5	I2: Current Analog Input						
		6	Int 485						
		8	Fieldbus (Ethernet)						
Cn.54	Positive-direction reverse torque limit	0.0-300.0%		180	◆R/W	dr.9= 4	i	0h1436	4-106
Cn.55	Positive-direction regeneration torque limit	0.0-200.0%		180	◆R/W	dr.9= 4	i	0h1437	4-106
Cn.56	Negative-direction regeneration torque limit	0.0-200.0%		180	◆R/W	dr.9= 4	i	0h1438	4-106
Cn.57	Negative-direction reverse torque limit	0.0-300.0%		180	◆R/W	dr.9= 4	i	0h1439	4-106
Cn.70	Speed search mode selection	0	Flying Start-1	0: Flying Start-1	R/W	-	v, s, i	0h1446	4-113
		1	Flying Start-2						
Cn.71	Speed search operation selection	bit	0000- 1111	0000	R/W	-	v, s, i	0h1447	4-113
		0001	Selection of speed search on acceleration						
		0010	When starting on initialization after fault trip						
		0100	When restarting after instantaneous power interruption						
		1000	When starting with power on						
Cn.72	Speed search reference current	80-200%		150	◆R/W	Cn.70=0 and Cn.71 any bit set to 1	v, s, i	0h1448	4-113
Cn.73	Speed search proportional gain	0-9999		Flying Start-1 : 100	◆R/W	Cn.71. any bit set to 1	v, s, i	0h1449	4-113
				Flying Start-2 : 600					

CONTROL Parameter Group (Cn)									
Pr. Code	Name	Setting Range		Initial Value	Run R/W	Parameter Dependency	Compatible Control Mode	Comm. Address (Hex)	Ref.
Cn.74	Speed search integral gain	0–9999		Flying Start–1 : 200	◆R/W	Cn.71. any bit set to 1	v, s, i	0h144A	4–113
				Flying Start–2 : 1000					
Cn.75	Output blocking time before speed search	0.0–60.0s		1.0	R/W	Cn.71. any bit set to 1	v, s, i	0h144B	4–113
Cn.76	Speed search Estimator gain	50–150%		100	◆R/W	Cn.71. any bit set to 1	v, s, i	0h144C	–
Cn.77	Energy buffering selection	0	No	0: No	R/W	–	v, s, i	0h144D	4–109
		1	KEB–1						
		2	KEB–2						
Cn.78	Energy buffering start level	110.0–200.0%		125.0	R/W	Cn.77≠0	v, s, i	0h144E	4–109
Cn.79	Energy buffering stop level	Cn.78–210.0%		130.0	R/W	Cn.77≠0	v, s, i	0h144F	4–109
Cn.80	Energy buffering P gain	0–20000		1000	◆R/W	Cn.77≠0	v, s, i	0h1450	4–109
Cn.81	Energy buffering I gain	1–20000		500	◆R/W	Cn.77≠0	v, s, i	0h1451	4–109
Cn.82	Energy buffering Slip gain	0–2000.0%		30.0	◆R/W	Cn.77≠0	v, s, i	0h1452	4–109
Cn.83	Energy buffering acceleration time	0.0–600.0s		10.0	◆R/W	Cn.77≠0	v, s, i	0h1453	4–109

INPUT PARAMETER GROUP (In)

The INPUT parameter group is labeled using *In*.

See "Table Legend" on page 4-3 for details on each column in the table below.

INPUT Parameter Group (In)									
Pr. Code	Name	Setting Range		Initial Value	Run R/W	Parameter Dependency	Compatible Control Mode	Comm. Address (Hex)	Ref.
In.0	Jump Code	1-99		65	◆R/W	-	v, s, i	-	3-6
In.1	Frequency for maximum analog input	Start frequency-Maximum frequency(Hz)		Maximum frequency	◆R/W	-	v, s, i	0h1501	4-46
In.2	Torque at maximum analog input	0.0-200.0%		100.0	◆R/W	-		0h1502	4-105
In.5	V1 input voltage display	-12.00-12.00V		0.00	Read Only	-	v, s, i	0h1505	4-46
In.6	V1 input polarity selection	0	Unipolar	0: Unipolar	R/W	-	v, s, i	0h1506	4-46
		1	Bipolar						
In.7	Time constant of V1 input filter	0-10000(ms)		100	◆R/W	-	v, s, i	0h1507	4-46
In.8	V1 Minimum input voltage	0.00-10.00V		0.00	◆R/W	-	v, s, i	0h1508	4-46
In.9	V1 output at Minimum voltage (%)	0.00-100.00%		0.00	◆R/W	-	v, s, i	0h1509	4-46
In.10	V1 Maximum input voltage	0.00-12.00V		10.00	◆R/W	-	v, s, i	0h150A	4-46
In.11	V1 output at Maximum voltage (%)	0.00-100.00%		100.00	◆R/W	-	v, s, i	0h150B	4-46
In.12	V1 Minimum input voltage	-10.00- 0.00V		0.00	◆R/W	In.6=1	v, s, i	0h150C	4-49
In.13	V1 output at Minimum voltage (%)	-100.00-0.00%		0.00	◆R/W	In.6=1	v, s, i	0h150D	4-49
In.14	V1 Maximum input voltage	-12.00- 0.00V		-10.00	◆R/W	In.6=1	v, s, i	0h150E	4-49
In.15	V1 output at Maximum voltage (%)	-100.00-0.00%		-100.00	◆R/W	In.6=1	v, s, i	0h150F	4-49
In.16	V1 rotation direction change	0	No	0: No	◆R/W	-	v, s, i	0h1510	4-46
		1	Yes						
In.17	V1 quantization level	0.00, 0.04-10.00%		0.04	R/W	-	v, s, i	0h1511	4-46
In.35	V0 input voltage display	0.00-5.00V		0.00	Read Only		v, s, i	0h1523	4-45
In.37	V0 input filter time constant	0-10000(ms)		100	◆R/W		v, s, i	0h1525	4-45
In.38	V0 Minimum input voltage	0.00-5.00V		0.00	◆R/W		i	0h1526	4-45
In.39	V0 output at Minimum voltage (%)	0.00-100.00%		0.00	◆R/W		v, s, i	0h1527	4-45

INPUT Parameter Group (In)									
Pr. Code	Name	Setting Range		Initial Value	Run R/W	Parameter Dependency	Compatible Control Mode	Comm. Address (Hex)	Ref.
In.40	V0 Maximum input voltage	0.00–5.00V		5	◆R/W		i	0h1528	4–45
In.41	V0 output at Maximum voltage (%)	0.00–100.00%		100.00	◆R/W		v, s, i	0h1529	4–45
In.46	V0 rotation direction change	0	No	0: No	◆R/W	Analog Input Dipswitch =V	v, s, i	0h152E	4–45
		1	Yes						
In.47	V0 quantization level	0.00, 0.04– 10.00%		0.04	◆R/W		v, s, i	0h152F	4–45
In.50	I2 input current display	0–24 mA		0.00	Read Only		v, s, i	0h1532	4–51
In.52	I2 input filter time constant	0–10000ms		100	◆R/W		v, s, i	0h1534	4–51
In.53	I2 minimum input current	0.00–20.00 mA		4.00	◆R/W		v, s, i	0h1535	4–51
In.54	I2 output at Minimum current (%)	0.00–100.00%		0.00	◆R/W		v, s, i	0h1536	4–51
In.55	I2 maximum input current	0.00–20.00mA		20.00	◆R/W		v, s, i	0h1537	4–51
In.56	I2 output at Maximum current (%)	0.00–100.00%		100.00	◆R/W		v, s, i	0h1538	4–51
In.61	Changing rotation direction of I2	0	No	0: No	◆R/W	Analog Input Dipswitch =I	v, s, i	0h153D	4–51
		1	Yes						
In.62	I2 quantization level	0.00, 0.04–10.00%		0.04	◆R/W		v, s, i	0h153E	4–51

INPUT Parameter Group (In)									
Pr. Code	Name	Setting Range		Initial Value	Run R/W	Parameter Dependency	Compatible Control Mode	Comm. Address (Hex)	Ref.
In.65	P1 terminal function setting	0	None	1: Fx	R/W	–	v, s, i	0h1541	
		1	Fx						4-55
		2	Rx						4-151
		3	RST						4-145
		4	External Trip						4-151
		5	BX (Block)						4-88
		6	JOG						4-53
		7	Speed-L						
		8	Speed-M						
		9	Speed-H						4-63
		11	XCEL-L						
		12	XCEL-M						4-92
		13	RUN Enable						4-58
		14	3-Wire						4-80
		15	2nd Source						4-120
		16	Exchange						4-89
		17	Up (Speed)						
		18	Down (Speed)						4-52
		20	U/D Clear						4-97
		21	Analog Hold						
		22	I-Term Clear						4-68
		23	PID Openloop						
		24	P Gain2						4-119
		25	XCEL Stop						4-89
		26	2nd Motor						4-137
		27	U/D Enable						
		33	Base Block						4-74
		34	Pre Excite						4-125
38	Timer In	4-84							
40	dis Aux Ref	4-89							
46	FWD JOG	4-89							
47	REV JOG	4-63							
49	XCEL-H	4-82							
51	Fire Mode	4-109							
52	KEB-1 Select								
In.66	P2 terminal function setting	See In.65 for Setting Range		2: Rx	R/W	–	v, s, i	0h1542	See In.65
In.67	P3 terminal function setting	See In.65 for Setting Range		5: BX (block)	R/W	–	v, s, i	0h1543	See In.65
In.68	P4 terminal function setting	See In.65 for Setting Range		3: RST	R/W	–	v, s, i	0h1544	See In.65
In.69	P5 terminal function setting	See In.65 for Setting Range		7: Speed-L	R/W	–	v, s, i	0h1545	See In.65

INPUT Parameter Group (In)									
Pr. Code	Name	Setting Range	Initial Value	Run R/W	Parameter Dependency	Compatible Control Mode	Comm. Address (Hex)	Ref.	
In.84	Multi-function input terminal On filter selection	Bit Value:		1 1111	◆R/W	-	v, s, i	0h1554	4-81
		0	Disable						
		1	Enable						
		Bit Assignment:							
		0	P1						
		1	P2						
		2	P3						
		3	P4						
4	P5								
In.85	Multi-function input terminal On filter	0-10000(ms)	10	◆R/W	-	v, s, i	0h1555	4-81	
In.86	Multi-function input terminal Off filter	0-10000(ms)	3	◆R/W	-	v, s, i	0h1556	4-81	
In.87	Multi-function input contact selection	Bit Value:		0 0000	R/W	-	v, s, i	0h1557	4-81
		0	Norm Open(A)						
		1	Norm Closed(B)						
		Bit Assignment:							
		0	P1						
		1	P2						
		2	P3						
		3	P4						
4	P5								
In.88	Selects the NO/NC operation command	0	NO	0	R/W	-	v, s, i	0h1558	
		1	NC						
In.89	Multi-step command delay time	1-5000(ms)	1	R/W	-	v, s, i	0h1559	4-53	
In.90	Multi-function input terminal monitor status	Bit Value:		0 0000	Read Only	-	v, s, i	0h155A	4-81
		0	Off						
		1	On						
		Bit Assignment:							
		0	P1						
		1	P2						
		2	P3						
		3	P4						
4	P5								
In.99	"SW1(NPN/PNP) status"	Bit	0-1	00	Read Only	-	v, s, i	0h1563	-
		00	NPN						
		01	PNP						

OUTPUT PARAMETER GROUP (OU)

The OUTPUT parameter group is labeled using *OU*.

See "Table Legend" on page 4-3 for details on each column in the table below.

OUTPUT Parameter Group (OU)									
Pr. Code	Name	Setting Range		Initial Value	Run R/W	Parameter Dependency	Compatible Control Mode	Comm. Address (Hex)	Ref.
OU.0	Jump Code	1-99		30	◆R/W	–	v, s, i	–	3-6
OU.1	Analog output 1 Mode	0	Frequency	0: Frequency	◆R/W	–	v, s, i	0h1601	4-128
		1	Output Current						
		2	Output Voltage						
		3	DCLink Voltage						
		4	Torque						
		5	Output Power						
		6	Idse						
		7	Iqse						
		8	Target Freq						
		9	Ramp Freq						
		10	Speed Fdb						
		12	PID Ref Value						
		13	PID Fdb Value						
		14	PID Output						
		15	Constant						
OU.2	Analog output 1 gain	-1000.0-1000.0%		100.0	◆R/W	–	v, s, i	0h1602	4-128
OU.3	Analog output 1 bias	-100.0-100.0%		0.0	◆R/W	–	v, s, i	0h1603	4-128
OU.4	Analog output 1 filter	0-10000(ms)		5	◆R/W	–	v, s, i	0h1604	4-128
OU.5	Analog constant output 1	0.0-100.0%		0.0	◆R/W	–	v, s, i	0h1605	4-128
OU.6	Analog output 1 monitor	0.0-1000.0%		0.0	Read Only	–	v, s, i	0h1606	4-128
OU.30	Fault output item	bit	000-111	010	◆R/W	–	v, s, i	0h161E	4-135
		001	Low voltage						
		010	Any faults other than low voltage						
		100	Automatic restart final failure						

OUTPUT Parameter Group (OU)								
Pr. Code	Name	Setting Range	Initial Value	Run R/W	Parameter Dependency	Compatible Control Mode	Comm. Address (Hex)	Ref.
OU.31	Multi-function Output Relay1 Setting (A1, B1, C1 terminals)	0	None	29: Trip	◆R/W	-	v, s, i	4-131
		1	FDT-1					
		2	FDT-2					
		3	FDT-3					
		4	FDT-4					
		5	Over Load					
		6	IOL					
		7	Under Load					
		8	Fan Warning					
		9	Stall					
		10	Over Voltage					
		11	Low Voltage					
		12	Over Heat					
		13	Lost Command					
		14	Run					
		15	Stop					
		16	Steady					
		17	Drive Line					
		18	Comm Line					
		19	Speed Search					
		21	Regeneration					
		22	Ready					
		23	Zero Speed					
		28	Timer Out					
		29	Trip					
31	DB Warn%ED							
34	On/Off Control							
35	BR Control							
36	Reserved							
37	Fan Exchange							
38	Fire Mode							
40	KEB Operating							
41	Pre Overhead							
42	Minor Fault							
43	Torque Detect1							
44	Torque Detect2							
45	PID Sleep							
OU.33	Multi-function Output Relay2 setting (A2,C2 terminals)	See OU.31 values	14: Run	◆R/W	-	v, s, i	0h1621	4-131
OU.41	Multi-function output monitor	Monitor status of Relay1 and Relay2	00	Read Only	-	v, s, i	0h1629	4-131

OUTPUT Parameter Group (OU)									
Pr. Code	Name	Setting Range	Initial Value	Run R/W	Parameter Dependency	Compatible Control Mode	Comm. Address (Hex)	Ref.	
OU.50	Multi-function output On delay	0.00–100.00s	0.00	◆R/W	–	v, s, i	0h1632	4–136	
OU.51	Multi-function output Off delay	0.00–100.00s	0.00	◆R/W	–	v, s, i	0h1633	4–136	
OU.52	Multi-function output contact selection	Bit Value:	00	R/W	–	v, s, i	0h1634	4–136	
		0 = A Contact (NO)							
		1 = B Contact (NC)							
OU.53	Fault output On delay	0.00–100.00s	0.00	◆R/W	–	v, s, i	0h1635	4–135	
OU.54	Fault output Off delay	0.00–100.00s	0.00	◆R/W	–	v, s, i	0h1636	4–135	
OU.55	Timer On delay	0.00–100.00s	0.00	◆R/W	–	v, s, i	0h1637	4–125	
OU.56	Timer Off delay	0.00–100.00s	0.00	◆R/W	–	v, s, i	0h1638	4–125	
OU.57	Detected frequency (FDT)	0.00–Maximum frequency(Hz)	30.00	◆R/W	–	v, s, i	0h1639	4–131	
OU.58	Detected frequency band (FDT)	0.00–Maximum frequency(Hz)	10.00	◆R/W	–	v, s, i	0h163A	4–131	
OU.67	Torque detection 1 operation setting	0	None	0:None	R/W	OU.31 or OU.33 = 43	v, s, i	0h1643	4–154
		1	OT CmdSpd Warn						
		2	OT Warning						
		3	OT CmdSpdTrip						
		4	OT Trip						
		5	UT CmdSpd Warn						
		6	UT Warning						
		7	UT CmdSpdTrip						
8	UT Trip								
OU.68	Torque detection 1 level	0.0–200.0	100.0	◆R/W	OU.31 or OU.33 = 43	v, s, i	0h1644	4–154	
OU.69	Torque detection 1 delay time	0–100	1.0	◆R/W	OU.31 or OU.33 = 43	v, s, i	0h1645	4–154	
OU.70	Torque detection 2 operation setting	0	None	0:None	R/W	OU.31 or OU.33 = 44	v, s, i	0h1646	4–154
		1	OT CmdSpd Warn						
		2	OT Warning						
		3	OT CmdSpdTrip						
		4	OT Trip						
		5	UT CmdSpd Warn						
		6	UT Warning						
		7	UT CmdSpdTrip						
8	UT Trip								
OU.71	Torque detection 2 level	0.0–200.0	100.0	◆R/W	OU.31 or OU.33 = 44	v, s, i	0h1647	4–154	
OU.72	Torque detection 2 delay time	0–100	1.0	◆R/W	OU.31 or OU.33 = 44	v, s, i	0h1648		

COMMUNICATION PARAMETER GROUP (CM)

The COMMUNICATION parameter group is labeled using CM.

See "Table Legend" on page 4-3 for details on each column in the table below.

COMMUNICATION Parameter Group (CM)									
Pr. Code	Name	Setting Range		Initial Value	Run R/W	Parameter Dependency	Compatible Control Mode	Comm. Address (Hex)	Ref.
CM.0	Jump Code	1-99		20	◆R/W	–	v, s, i	–	3-6
CM.1	Built-in communication drive ID	1-250		1	◆R/W	–	v, s, i	0h1701	5-7
CM.2	Built-in communication protocol	0	ModBus RTU	0: ModBus RTU	◆R/W	–	v, s, i	0h1702	5-7
		2	Not supported						
CM.3	Built-in communication speed	0	1200 bps	3: 9600 bps	◆R/W	–	v, s, i	0h1703	5-7
		1	2400 bps						
		2	4800 bps						
		3	9600 bps						
		4	19200 bps						
		5	38400 bps						
		6	56 Kbps						
		7	115 Kbps						
CM.4	Built-in communication frame setting	0	D8/PN/S1	0: D8/PN/S1	◆R/W	–	v, s, i	0h1704	5-7
		1	D8/PN/S2						
		2	D8/PE/S1						
		3	D8/PO/S1						
CM.5	Transmission delay after reception	0-1000(ms)		5ms	◆R/W	–	v, s, i	0h1705	5-7
CM.6	Ethernet Module (Fbus) S/W version	–		0.00	◆R/W	ACG-ET2 Installed	v, s, i	0h1706	–
CM.7	Communication option drive ID	0-255		1.00	◆R/W	ACG-ET2 Installed	v, s, i	0h1707	
CM.8	Ethernet Module (Fbus) communication speed	–		12Mbps	Read Only	ACG-ET2 Installed	v, s, i	0h1708	
CM.9	Ethernet Module (Fbus) LED status	–		–	Read Only	ACG-ET2 Installed	v, s, i	0h1709	–
CM.10	Opt Parameter 1 (IP address 1st octet)	0-255		192	R/W	ACG-ET2 Installed	v, s, i	0h170A	B-8
CM.11	Opt Parameter 2 (IP address 2nd octet)	0-255		168	R/W	ACG-ET2 Installed	v, s, i	0h170B	B-8
CM.12	Opt Parameter 3 (IP address 3rd octet)	0-255		1	R/W	ACG-ET2 Installed	v, s, i	0h170C	B-8

COMMUNICATION Parameter Group (CM)								
Pr. Code	Name	Setting Range	Initial Value	Run R/W	Parameter Dependency	Compatible Control Mode	Comm. Address (Hex)	Ref.
CM.13	Opt Parameter 4 (IP address 4th octet)	0–255	101	R/W	ACG–ET2 Installed	v, s, i	0h170D	B–8
CM.14	Opt Parameter 5 (IP Mask 1st octet)	0–255	255	R/W	ACG–ET2 Installed	v, s, i	0h170E	B–8
CM.15	Opt Parameter 6 (IP Mask 2nd octet)	0–255	255	R/W	ACG–ET2 Installed	v, s, i	0h170F	B–8
CM.16	Opt Parameter 7 (IP Mask 3rd octet)	0–255	255	R/W	ACG–ET2 Installed	v, s, i	0h1710	B–8
CM.17	Opt Parameter 8 (IP Mask 4th octet)	0–255	0	R/W	ACG–ET2 Installed	v, s, i	0h1711	B–8
CM.18	Opt Parameter 9 (IP Gateway 1st octet)	0–255	192	R/W	ACG–ET2 Installed	v, s, i	0h1712	B–8
CM.19	Opt Parameter 10 (IP Gateway 2nd octet)	0–255	168	R/W	ACG–ET2 Installed	v, s, i	0h1713	B–8
CM.20	Opt Parameter 11 (IP Gateway 3rd octet)	0–255	1	R/W	ACG–ET2 Installed	v, s, i	0h1714	B–8
CM.21	Opt Parameter 12 (IP Gateway 4th octet)	0–255	10	R/W	ACG–ET2 Installed	v, s, i	0h1715	B–8
CM.22	Opt Parameter 13 (Network Comm Speed)	0	0	R/W	ACG–ET2 Installed	v, s, i	0h1716	B–8
CM.23	Opt Parameter 14 (CIP Input Instance)	0–11	1	R/W	ACG–ET2 Installed	v, s, i	0h1717	B–8
CM.24	Opt Parameter 15 (CIP Output Instance)	0–11	1	R/W	ACG–ET2 Installed	v, s, i	0h1718	B–8
CM.30	Number of output parameters	0–16	3	◆R/W	–	v, s, i	0h171E	–
CM.31	Output Communication Address–1	0000–FFFF Hex	000A	◆R/W	–	v, s, i	0h171F	5–10
CM.32	Output Communication Address–2	0000–FFFF Hex	000E	◆R/W	–	v, s, i	0h1720	5–10
CM.33	Output Communication Address–3	0000–FFFF Hex	000F	◆R/W	–	v, s, i	0h1721	5–10

COMMUNICATION Parameter Group (CM)								
Pr. Code	Name	Setting Range	Initial Value	Run R/W	Parameter Dependency	Compatible Control Mode	Comm. Address (Hex)	Ref.
CM.34	Output Communication Address-4	0000-FFFF Hex	0000	◆R/W	–	v, s, i	0h1722	5-10
CM.35	Output Communication Address-5	0000-FFFF Hex	0000	◆R/W	–	v, s, i	0h1723	5-10
CM.36	Output Communication Address-6	0000-FFFF Hex	0000	◆R/W	–	v, s, i	0h1724	5-10
CM.37	Output Communication Address-7	0000-FFFF Hex	0000	◆R/W	–	v, s, i	0h1725	5-10
CM.38	Output Communication Address-8	0000-FFFF Hex	0000	◆R/W	–	v, s, i	0h1726	5-10
CM.39	Output Communication Address-9	0000-FFFF Hex	0000	◆R/W	–	v, s, i	0h1727	5-10
CM.40	Output Communication Address-10	0000-FFFF Hex	0000	◆R/W	–	v, s, i	0h1728	5-10
CM.41	Output Communication Address-11	0000-FFFF Hex	0000	◆R/W	–	v, s, i	0h1729	5-10
CM.42	Output Communication Address-12	0000-FFFF Hex	0000	◆R/W	–	v, s, i	0h172A	5-10
CM.43	Output Communication Address-13	0000-FFFF Hex	0000	◆R/W	–	v, s, i	0h172B	5-10
CM.44	Output Communication Address-14	0000-FFFF Hex	0000	◆R/W	–	v, s, i	0h172C	5-10
CM.45	Output Communication Address-15	0000-FFFF Hex	0000	◆R/W	–	v, s, i	0h172D	5-10
CM.46	Output Communication Address-16	0000-FFFF Hex	0000	◆R/W	–	v, s, i	0h172E	5-10
CM.50	Number of input parameters	0-16	2	◆R/W	–	v, s, i	0h1732	–
CM.51	Input Communication address 1	0000-FFFF Hex	0005	R/W	–	v, s, i	0h1733	5-10
CM.52	Input Communication address 2	0000-FFFF Hex	0006	R/W	–	v, s, i	0h1734	5-10
CM.53	Input Communication address 3	0000-FFFF Hex	0000	R/W	–	v, s, i	0h1735	5-10
CM.54	Input Communication address 4	0000-FFFF Hex	0000	R/W	–	v, s, i	0h1736	5-10

COMMUNICATION Parameter Group (CM)									
Pr. Code	Name	Setting Range		Initial Value	Run R/W	Parameter Dependency	Compatible Control Mode	Comm. Address (Hex)	Ref.
CM.55	Input Communication address 5	0000–FFFF Hex		0000	R/W	–	v, s, i	0h1737	5–10
CM.56	Input Communication address 6	0000–FFFF Hex		0000	R/W	–	v, s, i	0h1738	5–10
CM.57	Input Communication address 7	0000–FFFF Hex		0000	R/W	–	v, s, i	0h1739	5–10
CM.58	Input Communication address 8	0000–FFFF Hex		0000	R/W	–	v, s, i	0h173A	5–10
CM.59	Input Communication address 9	0000–FFFF Hex		0000	R/W	–	v, s, i	0h173B	5–10
CM.60	Input Communication address 10	0000–FFFF Hex		0000	R/W	–	v, s, i	0h173C	5–10
CM.61	Input Communication address 11	0000–FFFF Hex		0000	R/W	–	v, s, i	0h173D	5–10
CM.62	Input Communication address 12	0000–FFFF Hex		0000	R/W	–	v, s, i	0h173E	5–10
CM.63	Input Communication address 13	0000–FFFF Hex		0000	R/W	–	v, s, i	0h173F	5–10
CM.64	Input Communication address 14	0000–FFFF Hex		0000	R/W	–	v, s, i	0h1740	5–10
CM.65	Input Communication address 15	0000–FFFF Hex		0000	R/W	–	v, s, i	0h1741	5–10
CM.66	Input Communication address 16	0000–FFFF Hex		0000	R/W	–	v, s, i	0h1742	5–10
CM.68	Fieldbus (Ethernet) data swap	0	No	0	R/W	–	v, s, i	0h1744	5–10
		1	Not Supported						

COMMUNICATION Parameter Group (CM)									
Pr. Code	Name	Setting Range		Initial Value	Run R/W	Parameter Dependency	Compatible Control Mode	Comm. Address (Hex)	Ref.
CM.70	Communication multi-function input 1	0	None	0: None	◆R/W	-	v, s, i	0h1746	5-9
		1	Fx						
		2	Rx						
		3	RST						
		4	External Trip						
		5	BX						
		6	JOG						
		7	Speed-L						
		8	Speed-M						
		9	Speed-H						
		11	XCEL-L						
		12	XCEL-M						
		13	RUN Enable						
		14	3-Wire						
		15	2nd Source						
		16	Exchange						
		17	Up						
		18	Down						
		20	U/D Clear						
		21	Analog Hold						
		22	I-Term Clear						
		23	PID Openloop						
		24	P Gain2						
		25	XCEL Stop						
		26	2nd Motor						
		27	U/D Enable						
		33	Baseblock						
		34	Pre Excite						
38	Timer In								
40	dis Aux Ref								
46	FWD JOG								
47	REV JOG								
49	XCEL-H								
51	Fire Mode								
52	KEB-1 Select								
CM.71	Communication multi-function input 2	See CM.70 for Values		0: None	◆R/W	-	v, s, i	0h1747	-
CM.72	Communication multi-function input 3	See CM.70 for Values		0: None	◆R/W	-	v, s, i	0h1748	-
CM.73	Communication multi-function input 4	See CM.70 for Values		0: None	◆R/W	-	v, s, i	0h1749	-

COMMUNICATION Parameter Group (CM)									
Pr. Code	Name	Setting Range		Initial Value	Run R/W	Parameter Dependency	Compatible Control Mode	Comm. Address (Hex)	Ref.
CM.74	Communication multi-function input 5	See CM.70 for Values		0: None	◆R/W	–	v, s	0h174A	–
CM.75	Communication multi-function input 6	See CM.70 for Values		0: None	◆R/W	–	v, s, i	0h174B	–
CM.76	Communication multi-function input 7	See CM.70 for Values		0: None	◆R/W	–	v, s, i	0h174C	–
CM.77	Communication multi-function input 8	See CM.70 for Values		0: None	◆R/W	–	v, s, i	0h174D	–
CM.86	Communication multi-function input monitoring	–		0	Read Only	–	v, s, i	0h1756	5–9
CM.90	Selection of data frame communication monitor	0	Int485	0	◆R/W	–	v, s, i	0h175A	–
		1	Keypad						
CM.91	Data frame Rev count	0–65535		0	◆R/W	–	v, s, i	0h175B	–
CM.92	Data frame Err count	0–65535		0	◆R/W	–	v, s, i	0h175C	–
CM.93	NAK frame count	0–65535		0	◆R/W	–	v, s, i	0h175D	–
CM.94	Communication data Save	0	No	0: No	R/W	ACG-ET2 Installed	v, s, i	–	B-8
		1	Yes						

APPLICATION PARAMETER GROUP (AP)

The APPLICATION parameter group is labeled using AP.

See "Table Legend" on page 4–3 for details on each column in the table below.

APPLICATION Parameter Group (AP)									
Pr. Code	Name	Setting Range		Initial Value	Run R/W	Parameter Dependency	Compatible Control Mode	Comm. Address (Hex)	Ref.
AP0	Jump Code	1–99		20	◆R/W	–	v, s, i	–	3–6
AP1	Application function selection	0	None	0: None	R/W	–	v, s, i	0h1801	4–97
		1	–						
		2	Proc PID						
AP16	PID output monitor	(%)		0.00	Read Only	AP1 = 2	v, s, i	0h1810	4–97
AP17	PID reference monitor	(%)		50.00	Read Only	AP1 = 2	v, s, i	0h1811	4–97
AP18	PID feedback monitor	(%)		0.00	Read Only	AP1 = 2	v, s, i	0h1812	4–97
AP19	PID reference setting	–100.00–100.00%		50.00	◆R/W	AP1 = 2	v, s, i	0h1813	4–97
AP20	PID reference source	0	Keypad	0: Keypad	R/W	AP1 = 2	v, s, i	0h1814	4–97
		1	V1						
		3	V0						
		4	I2						
		5	Int 485						
		7	Fieldbus (Ethernet)						
AP21	PID feedback source	0	V1	0: V1	R/W	AP1 = 2	v, s, i	0h1815	4–97
		2	V0						
		3	I2						
		4	Int 485						
		6	Fieldbus (Ethernet)						
AP22	PID controller proportional gain	0.0–1000.0%		50.0	◆R/W	AP1 = 2	v, s, i	0h1816	4–97
AP23	PID controller integral time	0.0–200.0s		10.0	◆R/W	AP1 = 2	v, s, i	0h1817	4–97
AP24	PID controller differentiation time	0–1000(ms)		0	◆R/W	AP1 = 2	v, s, i	0h1818	4–97
AP25	PID controller feed–forward compensation gain	0.0–1000.0%		0.0	◆R/W	AP1 = 2	v, s, i	0h1819	4–97
AP26	Proportional gain scale	0.0–100.0%		100.0	R/W	AP1 = 2	v, s, i	0h181A	4–97
AP27	PID output filter	0–10000(ms)		0	◆R/W	AP1 = 2	v, s, i	0h181B	4–97
AP28	PID Mode	0	Process PID	0	R/W	AP1 = 2	v, s, i	0h181C	4–97
		1	Normal PID						
AP29	PID upper limit frequency	PID lower limit frequency–300.00Hz		60.00	◆R/W	AP1 = 2	v, s, i	0h181D	4–97

APPLICATION Parameter Group (AP)									
Pr. Code	Name	Setting Range		Initial Value	Run R/W	Parameter Dependency	Compatible Control Mode	Comm. Address (Hex)	Ref.
AP.30	PID lower limit frequency	-300.00 –PID upper limit frequency(Hz)		-60.00	◆R/W	AP.1 = 2	v, s, i	0h181E	4-97
AP.32	PID output scale	0.1-1000.0%		100.0	R/W	AP.1 = 2	v, s, i	0h1820	4-97
AP.33	PID output inverse	0	No	NO	R/W	AP.1 = 2	v, s, i	0h1821	
		1	Yes						
AP.34	PID controller motion frequency	0.00-Maximum frequency(Hz)		0.00	R/W	AP.1 = 2	v, s, i	0h1822	4-97
AP.35	PID controller motion level	0.0-100.0%		0.0	R/W	AP.1 = 2	v, s, i	0h1823	4-97
AP.36	PID controller motion delay time	0-9999s		600	◆R/W	AP.1 = 2	v, s, i	0h1824	4-97
AP.37	PID sleep mode delay time	0.0-999.9s		60.0	◆R/W	AP.1 = 2	v, s, i	0h1825	4-97
AP.38	PID sleep mode frequency	0.00-Maximum frequency(Hz)		0.00	◆R/W	AP.1 = 2	v, s, i	0h1826	4-97
AP.39	PID wake-up level	0-100%		35	◆R/W	AP.1 = 2	v, s, i	0h1827	4-97
AP.40	PID wake-up mode setting	0	Below Level	0: Below Level	◆R/W	AP.1 = 2	v, s, i	0h1828	4-97
		1	Above Level						
		2	Beyond Level						
AP.43	PID unit gain	0.00-300.00%		100.00	◆R/W	AP.1 = 2	v, s, i	0h182B	4-97
AP.44	PID unit scale	0	x100	2: x 1	◆R/W	AP.1 = 2	v, s, i	0h182C	4-97
		1	x10						
		2	x 1						
		3	x 0.1						
		4	x 0.01						
AP.45	PID 2nd proportional gain	0.0-1000.0%		100.0	R/W	AP.1 = 2	v, s, i	0h182D	4-97

PROTECTION PARAMETER GROUP (Pr)

The PROTECTION parameter group is labeled using *Pr*.

See "Table Legend" on page 4–3 for details on each column in the table below.

PROTECTION Parameter Group (Pr)									
Pr. Code	Name	Setting Range		Initial Value	Run R/W	Parameter Dependency	Compatible Control Mode	Comm. Address (Hex)	Ref.
Pr.0	Jump Code	1–99		40	◆R/W	–	v, s, i	–	3–6
Pr.4	Load level setting	0	Normal load (ND)	1: Heavy load (HD)	◆R/W	–	v, s, i	0h1B04	4–140
		1	Heavy load (HD)						
Pr.5	Input/output open-phase protection	bit	00–11	00	R/W	–	v, s, i	0h1B05	4–144
		01	Output open phase						
		10	Input open phase						
Pr.6	Input voltage range during open-phase	1–100V		15	R/W	–	v, s, i	0h1B06	4–144
Pr.7	Deceleration time at fault trip	0.0–600.0s		3.0	◆R/W	–	v, s, i	0h1B07	4–146
Pr.8	Selection of startup on trip reset	0	No	0: No	◆R/W	–	v, s, i	0h1B08	4–117
		1	Yes						
Pr.9	Number of automatic restarts	0–10		0	◆R/W	–	v, s, i	0h1B09	4–117
Pr.10	Automatic restart delay time	0.0–60.0s		1.0	◆R/W	Pr.9>0	v, s, i	0h1B0A	4–117
Pr.12	Motion at speed command loss	0	None	0: None	◆R/W	–	v, s, i	0h1B0C	4–146
		1	Free-Run						
		2	Dec						
		3	Hold Input						
		4	Hold Output						
		5	Lost Preset						
Pr.13	Time to decide speed command loss	0.1–120s		1.0	◆R/W	Pr.12>0	v, s, i	0h1B0D	4–146
Pr.14	Operation frequency at speed command loss	Start frequency– Maximum frequency(Hz)		0.00	◆R/W	Pr.12>0	v, s, i	0h1B0E	4–146
Pr.15	Analog input loss decision level	0	Half x1	0: Half x1	◆R/W	Pr.12>0	v, s, i	0h1B0F	4–146
		1	Below x1						
Pr.17	Overload warning selection	0	No	0: No	◆R/W	–	v, s, i	0h1B11	4–140
		1	Yes						
Pr.18	Overload alarm level	30–180%		150	◆R/W	–	v, s, i	0h1B12	4–140
Pr.19	Overload warning time	0.0–30.0s		10.0	◆R/W	–	v, s, i	0h1B13	4–140

PROTECTION Parameter Group (Pr)									
Pr. Code	Name	Setting Range		Initial Value	Run R/W	Parameter Dependency	Compatible Control Mode	Comm. Address (Hex)	Ref.
Pr.20	Motion at overload fault	0	None	1: Free-Run	◆R/W	-	v, s, i	0h1B14	4-140
		1	Free-Run						
		2	Dec						
Pr.21	Overload fault level	30-200%		180	◆R/W	-	v, s, i	0h1B15	4-140
Pr.22	Overload fault time	0.0-60.0s		60.0	◆R/W	-	v, s, i	0h1B16	4-140
Pr.25	Underload warning selection	0	No	0: No	◆R/W	-	v, s, i	0h1B19	4-149
		1	Yes						
Pr.26	Underload warning time	0.0-600.0s		10.0	◆R/W	-	v, s, i	0h1B1A	4-149
Pr.27	Underload fault selection	0	None	0: None	◆R/W	-	v, s, i	0h1B1B	4-149
		1	Free-Run						
		2	Dec						
		3	Underload sleep						
Pr.28	Underload fault time	0.0-600.0s		30.0	◆R/W	-	v, s, i	0h1B1C	4-149
Pr.29	Underload lower limit level	10-100%		30	◆R/W	-	v, s, i	0h1B1D	4-149
Pr.30	Underload upper limit level	10-100%		30	◆R/W	-	v, s, i	0h1B1E	4-149
Pr.31	No motor motion at detection	0	None	0: None	◆R/W	-	v, s, i	0h1B1F	4-152
		1	Free-Run						
Pr.32	No motor detection current level	1-100%		5	◆R/W	-	v, s, i	0h1B20	4-152
Pr.33	No motor detection delay	0.1-10.0s		3.0	◆R/W	-	v, s, i	0h1B21	4-152
Pr.40	Electronic thermal fault selection	0	None	0: None	◆R/W	-	v, s, i	0h1B28	4-138
		1	Free-Run						
		2	Dec						
Pr.41	Motor cooling fan type	0	Self-cool	0: Self-cool	◆R/W	-	v, s, i	0h1B29	4-138
		1	Forced-cool						
Pr.42	Electronic thermal 1 minute rating	120-200%		150	◆R/W	-	v, s, i	0h1B2A	4-138
Pr.43	Electronic thermal continuous rating	50-150%		120	◆R/W	-	v, s, i	0h1B2B	4-138
Pr.45	BX (Block) trip mode	0	Free-Run	0	R/W	-	v, s, i	0h1B2D	-
		1	Decelerate						

PROTECTION Parameter Group (Pr)									
Pr. Code	Name	Setting Range		Initial Value	Run R/W	Parameter Dependency	Compatible Control Mode	Comm. Address (Hex)	Ref.
Pr.50	Stall prevention motion and flux braking	bit	0000–1111	0000	R/W	–	v, s	0h1B32	4–141
		0001	Accelerating						
		0010	At constant speed						
		0100	At deceleration						
		1000	FluxBraking						
Pr.51	Stall frequency1	Start frequency – Stall frequency2 (Hz)		60.00	◆R/W	–	v, s	0h1B33	4–141
Pr.52	Stall level1	30–250%		180	R/W	–	v, s	0h1B34	4–141
Pr.53	Stall frequency2	Stall frequency1 – Stall frequency3 (Hz)		60.00	◆R/W	–	v, s	0h1B35	4–141
Pr.54	Stall level2	30–250%		180	R/W	–	v, s	0h1B36	4–141
Pr.55	Stall frequency3	Stall frequency2 – Stall frequency4 (Hz)		60.00	◆R/W	–	v, s	0h1B37	4–141
Pr.56	Stall level3	30–250%		180	R/W	–	v, s	0h1B38	4–141
Pr.57	Stall frequency4	Stall frequency3 – Maximum frequency (Hz)		60.00	◆R/W	–	v, s	0h1B39	4–141
Pr.58	Stall level4	30–250%		180	R/W	–	v, s	0h1B3A	4–141
Pr.59	Flux braking gain	0 – 150%		0	◆R/W	–	v, s, i	0h1B3B	–
Pr.66	DB resistor warning level	0–30%		10	◆R/W	–	v, s, i	0h1B42	4–147
Pr.77	Preoverheat warning temperature	90–110		90	◆R/W	–	v, s, i	0h1B4D	
Pr.78	Preoverheat warning operation selection	0	None	0	◆R/W	–	v, s, i	0h1B4E	
		1	Warning						
		2	Freerun						
		3	Decelerate						
Pr.79	Cooling fan fault selection	0	Trip	1: Warning	◆R/W	–	v, s, i	0h1B4F	4–150
		1	Warning						
Pr.80	Motion selection at option trip	0	None	1: Free–Run	◆R/W	–	v, s, i	0h1B50	4–151
		1	Free–Run						
		2	Decelerate						
Pr.81	Low voltage fault decision delay time	0.0–60.0s		0.0	R/W	–	v, s, i	0h1B51	
Pr.82	Low Voltage2 Trip Selection	0	No	0	R/W	–	v, s, i	0h1B52	4–153
		1	Yes						
Pr.86	Accumulated percent of fan usage	0.0 - 100.0%		0	Read Only	–	v, s, i	0h1B56	
Pr.87	Fan exchange warning level	0.0 - 100.0%		90	◆R/W	–	v, s, i	0h1B57	
Pr.88	Fan reset time	0 = No; 1 = Yes		0	R/W	–	v, s, i	0h1B58	

PROTECTION Parameter Group (Pr)									
Pr. Code	Name	Setting Range		Initial Value	Run R/W	Parameter Dependency	Compatible Control Mode	Comm. Address (Hex)	Ref.
Pr.89	FAN Status	Bit	00-01	00	Read Only	-	v, s, i	0h1B59	4-153
		00	None						
		01	Fan Exchange						
Pr.90¹	Relay Open Trip Selection	-		-	Read Only	-	v, s, i	-	6-7
Pr.91	Fault history 1	-		-	Read Only	-	v, s, i	0h1B5B	6-7
Pr.92	Fault history 2	-		-	Read Only	-	v, s, i	0h1B5C	6-7
Pr.93	Fault history 3	-		-	Read Only	-	v, s, i	0h1B5D	6-7
Pr.94	Fault history 4	-		-	Read Only	-	v, s, i	0h1B5E	6-7
Pr.95	Fault history 5	-		-	Read Only	-	v, s, i	0h1B5F	6-7
Pr.96	Fault history deletion	0	No	0: No	◆R/W	-	v, s, i	0h1B60	6-7
		1	Yes						

1 - Pr.90 can only be used with 460 VAC 2-5 hp drives.

2ND MOTOR PARAMETER GROUP (M2)

The M2 parameter group is labeled using M2.

See "Table Legend" on page 4-3 for details on each column in the table below.



NOTE: The 2nd Motor parameter group is only available when any one input configuration parameter (In.65 - In.69) is set to 26.

2nd MOTOR Parameter Group (M2)									
Pr. Code	Name	Setting Range		Initial Value	Run R/W	Parameter Dependency	Compatible Control Mode	Comm. Address (Hex)	Ref.
M2.0	Jump Code	1-99		14	◆R/W	–	v, s, i	–	3-6
M2.4	Acceleration time	0.0-600.0s		20.0	◆R/W	–	v, s, i	0h1C04	4-119
M2.5	Deceleration time	0.0-600.0s		30.0	◆R/W	–	v, s, i	0h1C05	4-119
M2.6	Motor capacity	0	0.2 kW (1/4 hp)	–	R/W	–	v, s, i	0h1C06	4-119
		1	0.4 kW (1/2 hp)						
		2	0.75 kW (1 hp)						
		3	1.1 kW (1.5 hp)						
		4	1.5 kW (2 hp)						
		5	2.2 kW (3 hp)						
		6	3.0 kW (4 hp)						
		7	3.7 kW (4 hp)						
		8	4.0 kW (5 hp)						
		9	5.5 kW (7.5 hp)						
		10	7.5 kW (10 hp)						
		11	11.0 kW (15 hp)						
		12	15.0 kW (20 hp)						
		13	18.5 kW (25 hp)						
		14	22.0 kW (30 hp)						
15	30.0 kW (40 hp)								
M2.7	Base frequency	30.00-400.00Hz		60.00	R/W	–	v, s, i	0h1C07	4-119
M2.8	Control mode	0	V/F	0: V/F	R/W	–	v, s, i	0h1C08	4-119
		2	Slip Compen						
		4	IM Sensorless						
M2.10	Number of motor poles	2-48		Dependent on motor settings	R/W	–	v, s, i	0h1C0A	4-119
M2.11	Rated slip speed	0-3000(rpm)		Dependent on motor settings	R/W	–	v, s, i	0h1C0B	4-119
M2.12	Motor rated current	1.0-1000.0A		Dependent on motor settings	R/W	–	v, s, i	0h1C0C	4-119
M2.13	Motor no-load current	0.5-1000.0A		Dependent on motor settings	R/W	–	v, s, i	0h1C0D	4-119
M2.14	Motor rated voltage	170-480V		Dependent on motor settings	R/W	–	v, s, i	0h1C0E	4-119

2nd MOTOR Parameter Group (M2)									
Pr. Code	Name	Setting Range		Initial Value	Run R/W	Parameter Dependency	Compatible Control Mode	Comm. Address (Hex)	Ref.
M2.15	Motor efficiency	64–100%		Dependent on motor settings	R/W	–	v, s, i	0h1C0F	4–119
M2.16	Load inertia rate	0–8		Dependent on motor settings	R/W	–	v, s, i	0h1C10	4–119
M2.17	Stator resistance	Dependent on motor settings		Dependent on motor settings	R/W	–	v, s, i	–	4–119
M2.18	Leakage inductance	–		Dependent on motor settings	R/W	–	v, s, i	–	4–119
M2.19	Stator inductance	–		Dependent on motor settings	R/W	–	v, s, i	–	4–119
M2.20	Rotor time constant	25–5000(ms)		Dependent on motor settings	R/W	M2.08=4 IM Sensorless	v, s, i	–	4–119
M2.25	V/F pattern	0	Linear	0: Linear	R/W	–	v, s, i	0h1C19	4–119
		1	Square						
		2	User V/F						
M2.26	Forward Torque boost	0.0–15.0%		2.0	R/W	–	v, s, i	0h1C1A	4–119
M2.27	Reverse Torque boost	0.0–15.0%		2.0	R/W	–	v, s, i	0h1C1B	4–119
M2.28	Stall prevention level	30–150%		150	R/W	–	v, s, i	0h1C1C	4–119
M2.29	Electronic thermal 1 minute rating	100–200%		150	R/W	–	v, s, i	0h1C1D	4–119
M2.30	Electronic thermal continuous rating	50–Electronic thermal 1 minute rating		100	R/W	–	v, s, i	0h1C1E	4–119
M2.31	Low-speed torque compensation gain	50–300%		Varies by Motor capacity	R/W	–	i	0h1C1F	
M2.32	Stator leakage inductance scale	50–300%		Varies by Motor capacity	R/W	–	i	0h1C20	
M2.33	Stator inductance scale	50–300%		Varies by Motor capacity	R/W	–	i	0h1C21	
M2.34	Rotor time constant scale	50–300%		Varies by Motor capacity	R/W	–	i	0h1C12	
M2.40	Rotation count speed gain (RPM Display)	0.1–6000.0%		100.0	◆R/W	–	v, s, i	0h1C28	4–137
M2.41	Reserved	–		–	–	–	–	–	–
M2.42	Reserved	–		–	–	–	–	–	–

IRONHORSE® ACG DRIVE OPERATION AND PARAMETER DETAILS

This section describes in detail the function of each parameter, parameter interaction, and how to configure drive functionality via parameters. There are 3 main sections:

- 1) Learning Basic Features
- 2) Learning Advanced Features
- 3) Learning Protection Features

Pr. Group	Pr. Code	Name	Parameter Setting	Setting Range	Unit
x	x	x	x	x	x

CHART KEY

- *Group = Parameter Group, designated by one of the following:*
 - » *2 letter group abbreviation*
 - » *Operation (initial parameter group on Drive LED with no 2 letter designation)*
- *Code = Parameter number, or full parameter group/code designation, i.e. dr.1*
- *Name = Parameter Description*
- *Parameter Setting = Applicable parameter setting value and function*
- *Setting Range = Full Range of parameter settings*
- *Unit = Engineering unit*



NOTE: Parameters can be restored to their default values using dr.93.

LEARNING BASIC FEATURES

This section describes the basic features of the ACG drive. Check the reference page in the table to see the detailed description for each of the advanced features.

Basic Tasks	Description	Ref.
Frequency reference source configuration for the keypad	Configures the drive to allow you to setup or modify frequency reference using the Keypad.	4-45
Frequency reference source configuration for the terminal block (input voltage)	Configures the drive to allow input voltages at the terminal block (V1, V0) and to setup or modify a frequency reference.	4-46 4-45
Frequency reference source configuration for the terminal block (input current)	Configures the drive to allow input currents at the terminal block (I2) and to setup or modify a frequency reference.	4-51
Frequency reference source configuration for RS-485 communication	Configures the drive to allow communication signals from upper level controllers, such as PLCs or PCs, and to setup or modify a frequency reference.	4-52
Frequency control using analog inputs	Enables the user to hold a frequency using analog inputs at terminals.	4-52
Multi-step speed (frequency) configuration	Configures multi-step frequency operations by receiving an input at the terminals defined for each step frequency.	4-53
Command source configuration for keypad buttons	Configures the drive to start operation with the [RUN] key on the keypad and stop with the [STOP/RESET] keys..	4-55
Command source configuration for terminal block inputs (2-wire and 3-wire)	Configures the drive to accept inputs at the FX/RX terminals.	4-56
Command source configuration for RS-485 communication	Configures the drive to accept communication signals from upper level controllers, such as PLCs or PCs.	4-59
Motor rotation control	Configures the drive to limit a motor's rotation direction.	4-59
Automatic start-up at power-on	Configures the drive to start operating at power-on. With this configuration, the drive begins to run and the motor accelerates as soon as power is supplied to the drive. To use automatic start-up configuration, the operation command terminals at the terminal block must be turned on.	4-60
Automatic restart after reset of a fault trip condition	Configures the drive to start operating when the drive is reset following a fault trip. In this configuration, the drive starts to run and the motor accelerates as soon as the drive is reset following a fault trip condition. For automatic start-up configuration to work, the operation command terminals at the terminal block must be turned on.	4-61
Acc/Dec time configuration based on the Max. Frequency	Configures the acceleration and deceleration times for a motor based on a defined maximum frequency.	4-62
Acc/Dec time configuration based on the frequency reference	Configures acceleration and deceleration times for a motor based on a defined frequency reference.	4-63
Multi-stage Acc/Dec time configuration using the multi-function terminal	Configures multi-stage acceleration and deceleration times for a motor based on defined parameters for the multi-function terminals.	4-63
Acc/Dec time transition speed (frequency) configuration	Enables modification of acceleration and deceleration gradients without configuring the multi-functional terminals.	4-64
Acc/Dec pattern configuration	Enables modification of the acceleration and deceleration gradient patterns. Basic patterns to choose from include linear and S-curve patterns.	4-66
Acc/Dec stop command	Stops the current acceleration or deceleration and controls motor operation at a constant speed. Multi-function terminals must be configured for this command.	4-68
Linear V/F pattern operation	Configures the drive to run a motor at a constant torque. To maintain the required torque, the operating frequency may vary during operation.	4-68
Square reduction V/F pattern operation	Configures the drive to run the motor at a square reduction V/F pattern. Fans and pumps are appropriate loads for square reduction V/F operation.	4-69
User V/F pattern configuration	Enables the user to configure a V/F pattern to match the characteristics of a motor. This configuration is for special-purpose motor applications to achieve optimal performance.	4-70
Manual torque boost	Manual configuration of the drive to produce a momentary torque boost. This configuration is for loads that require a large amount of starting torque, such as elevators or lifts.	4-71

Basic Tasks	Description	Ref.
Automatic torque boost	Automatic configuration of the drive that provides “auto tuning” that produces a momentary torque boost. This configuration is for loads that require a large amount of starting torque, such as elevators or lifts.	4-72
Output voltage adjustment	Adjusts the output voltage to the motor when the power supply to the drive differs from the motor’s rated input voltage.	4-73
Accelerating start	Accelerating start is the general way to start motor operation. The typical application configures the motor to accelerate to a target frequency in response to a run command, however there may be other start or acceleration conditions defined.	4-73
DC braking after Start	Configures the drive to perform DC braking before the motor starts rotating again. This configuration is used when the motor will be rotating before the voltage is supplied from the drive.	4-73
Deceleration stop	Deceleration stop is the typical method used to stop a motor. The motor decelerates to 0Hz and stops on a stop command, however there may be other stop or deceleration conditions defined.	4-75
Stopping by DC braking	Configures the drive to apply DC braking during motor deceleration. The frequency at which DC braking occurs must be defined and during deceleration, when the motor reaches the defined frequency, DC braking is applied.	4-76
Free-run stop	Configures the drive to stop output to the motor using a stop command. The motor will free-run until it slows down and stops.	4-77
Power braking	Configures the drive to provide optimal, motor deceleration, without tripping over-voltage protection.	4-77
Start/maximum frequency configuration	Configures the frequency reference limits by defining a start frequency and a maximum frequency.	4-78
Upper/lower frequency limit configuration	Configures the frequency reference limits by defining an upper limit and a lower limit.	4-78
Frequency jump	Configures the drive to avoid running a motor in mechanically resonating frequencies.	4-79
2nd Operation Configuration	Used to configure the 2nd operation mode and switch between the operation modes according to your requirements.	4-80
Multi-function input terminal control configuration	Enables the user to improve the responsiveness of the multi-function input terminals.	4-81

SETTING FREQUENCY REFERENCE

The ACG drive provides several methods to setup and modify a frequency reference for an operation. The keypad, analog inputs [for example voltage (V1) and current (I2) signals], or RS-485, and Fieldbus (Ethernet) option card can be used.

Pr. Group	Pr. Code	Name	Parameter Setting		Setting Range	Unit
Operation	Frq	Frequency reference source	0	Keypad-1: Change+Enter	0-8	-
			1	Keypad-2: Instant Change		
			2	V1: Analog Voltage Input		
			4	V0: Built-in Potentiometer Dial		
			5	I2: Analog Current Input		
			6	Int 485		
			8	Fieldbus (Ethernet)		

KEYPAD AS THE SOURCE (KEYPAD-1 SETTING)

You can modify frequency reference by using the keypad and apply changes by pressing the [ENT] key. To use the keypad as a frequency reference input source, go to the Frq (Frequency reference source) code in the Operation group and change the parameter value to 0 (Keypad-1). Input the frequency reference for an operation at the 0.00(Command Frequency) code in the Operation group.

Pr. Group	Pr. Code	Name	Parameter Setting		Setting Range	Unit
Operation	Frq	Frequency reference source	0	Keypad-1	0-8	-
	0.00	Frequency reference	0.00		Min to Max Frq*	Hz

You cannot set a frequency reference that exceeds the Max. Frequency, as configured with dr.20.

KEYPAD AS THE SOURCE (KEYPAD-2 SETTING)

You can use the Up Arrow and Down Arrow keys to modify a frequency reference. To use this as a second option, set the keypad as the source of the frequency reference, by going to the Frq (Frequency reference source) code in the Operation group and change the parameter value to 1 (Keypad-2). This allows frequency reference values to be increased or decreased by pressing the Up Arrow and Down Arrow keys.

Pr. Group	Pr. Code	Name	Parameter Setting		Setting Range	Unit
Operation	Frq	Frequency reference source	1	Keypad-2	0-8	-
	0.00	Frequency reference	0.00		Min to Max Frq*	Hz

You cannot set a frequency reference that exceeds the Max. Frequency, as configured with dr.20.

BUILT-IN POTENTIOMETER DIAL (V0) AS THE SOURCE

You can modify the frequency reference by using the built-in potentiometer dial. Go to the Frq (Frequency reference source) code in the Operation group and change the parameter value to 4, and then rotate the built-in potentiometer dial. You can monitor the parameter setting of the frequency reference at the 0.00 (command frequency) code in the Operation group.

Pr. Group	Pr. Code	Name	Parameter Setting		Setting Range	Unit
Operation	Frq	Frequency reference source	4	V0	0-8	-
In	In.1	Frequency at maximum analog input	60.00		0- Maximum Frequency	Hz
	In.35	V0 input voltage display	0.00		0.00-5.00	V
	In.37	Time constant of V0 input filter	100		0-10000	ms
	In.38	V0 minimum input voltage	0.00		0.00-5.00	V
	In.39	V0 output at minimum voltage (%)	0.00		0-100	%
	In.40	V0 maximum input voltage	5.00		0.00-5.00	V
	In.41	V0 output at maximum voltage (%)	100.00		0.00-100.00	%
	In.46	Changing rotation direction of V0	0	No	0-1	-
In.47	V0 quantization level	0.04		0*, 0.04-10.00	%	

**Quantizing is disabled if '0' is selected.*

V1 TERMINAL AS THE SOURCE

You can set and modify a frequency reference by setting voltage inputs when using the V1 terminal. Use voltage inputs ranging from 0 to 10V (unipolar) for forward only operation. Use voltage inputs ranging from -10 to +10V (bipolar) for both directions, where negative voltage inputs are used reverse operations.

Setting a Frequency Reference for 0-10V Input

Set In.6 (V1 Polarity) to 0 (unipolar). Use a voltage output from an external source or use the voltage output from the VR terminal to provide inputs to V1. Refer to the diagrams below for the wiring required for each application.

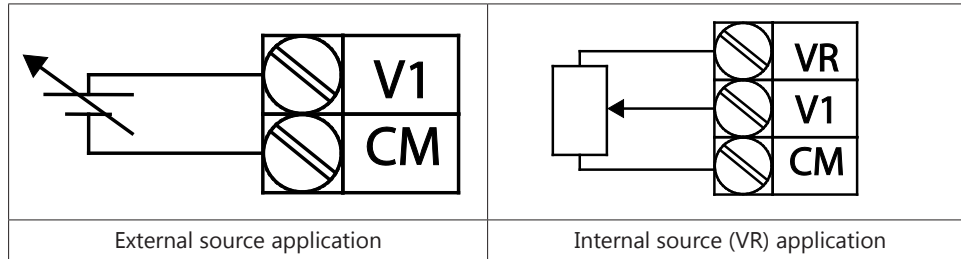

Pr. Group	Pr. Code	Name	Parameter Setting		Setting Range	Unit
Operation	Frq	Frequency reference source	2	V1	0-8	-
In	In.1	Frequency at maximum analog input	Maximum frequency		0.00- Max. Frequency	Hz
	In.5	V1 input monitor	0.00		0.00-12.00	V
	In.6	V1 polarity options	0	Unipolar	0-1	-
	In.7	V1 input filter time constant	100		0-10000	ms
	In.8	V1 minimum input voltage	0.00		0.00-10.00	V
	In.9	V1 output at minimum voltage (%)	0.00		0.00-100.00	%
	In.10	V1 maximum input voltage	10.00		0.00- 12.00	V
	In.11	V1 output at maximum voltage (%)	100.00		0-100	%
	In.16	Rotation direction options	0	No	0-1	-
	In.17	V1 Quantizing level	0.04		0.00*, 0.04-10.00	%

Quantizing is disabled if '0' is selected.

0-10V Input Voltage Setting Details

Pr. Code	Description
In.1 Freq at 100%	Configures the frequency reference at the maximum input voltage when a potentiometer is connected to the control terminal block. A frequency set with code In.1 becomes the maximum frequency only if the value set in code In.11 (or In.15) is 100%. Set code In.1 to 40.00 and use default values for codes In.2-In.16. Motor will run at 40.00 Hz when a 10V input is provided at V1. Set code In.11 to 50.00 and use default values for codes In.1-In.16. Motor will run at 30.00 Hz (50% of the default maximum frequency-60Hz) when a 10V input is provided at V1.
In.5 V1 MonitorV	Configures the drive to monitor the input voltage at V1.

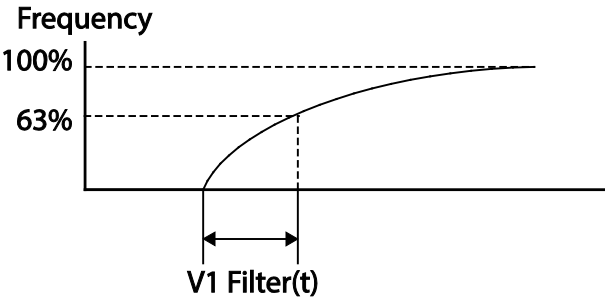
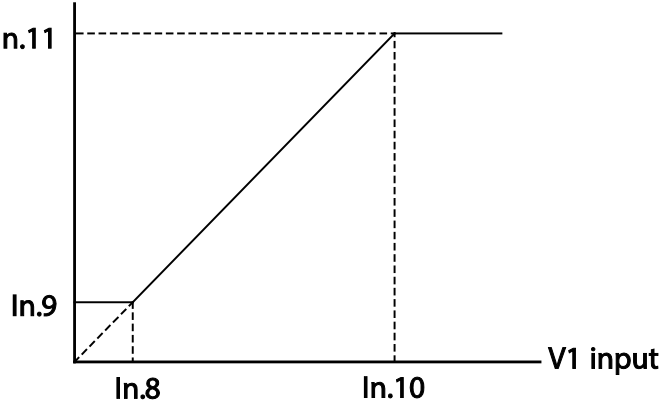
Pr. Code	Description
<p>In.7 V1 Filter</p>	<p>V1 Filter may be used when there are large variations between reference frequencies. Variations can be mitigated by increasing the time constant, but this will require an increased response time. The value t (time) indicates the time required for the frequency to reach 63% of the reference, when external input voltages are provided in multiple steps.</p> <p>V1 input from external source </p> 
<p>In.8 V1 minimum input voltage In.9 V1 output at minimum voltage (%) In.10 maximum input voltage In.11 V1 output at maximum voltage (%)</p>	<p>These parameters are used to configure the gradient level and offset values of the Output Frequency, based on the Input Voltage.</p> <p>Frequency reference</p> 
<p>In.16 V1 Inverting</p>	<p>Inverts the direction of rotation. Set this code to 1 (Yes) if you need the motor to run in the opposite direction from the current rotation.</p>

Pr. Code	Description
<p>In.17 V1 Quantizing</p>	<p>Quantizing may be used when the noise level is high in the analog input (V1 terminal) signal. Quantizing is useful when you are operating a noise-sensitive system, because it suppresses any signal noise. However, quantizing will diminish system sensitivity (resultant power of the output frequency will decrease based on the analog input). You can also turn on the low-pass filter using code In.7 to reduce the noise, but increasing the value will reduce responsiveness and may cause pulsations (ripples) in the output frequency.</p> <p>Parameter values for quantizing refer to a percentage based on the maximum input. Therefore, if the value is set to 1% of the analog maximum input (60Hz), the output frequency will increase or decrease by 0.6 Hz per 0.1 V difference.</p> <p>To reduce the effect of the input signal changes (runout of height) on the operation frequency, the output frequency during increase or decrease of input signal value (height) is applied differently. When the input signal value increases, the output frequency starts changing if the height becomes equivalent to 3/4 of the quantizing value. From then on, the output frequency increases according to the quantizing value. On the other hand, when the input signal decrease, the output frequency starts decreasing if the height becomes equivalent to 1/4 of the quantizing value.</p> <p>Although the noise can be reduced using the low-pass filter (In.7), the response on the input signal takes long as the set value gets higher. Since it becomes difficult to control the frequency if the input signal is delayed, a period of long pulse (ripple) may occur on the output frequency.</p>

Setting a Frequency Reference for -10~10V Input

Set the Frq (Frequency reference source) code in the Operation group to 2 (V1), and then set code 06 (V1 Polarity) to 1 (bipolar) in the Input Terminal group (IN). Use the voltage output of the external controller or use the VR terminal (frequency setting power terminal) of the control terminal to input voltage in the V1 terminal as the volume resistance.

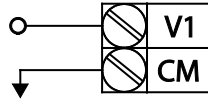

V1 terminal wiring

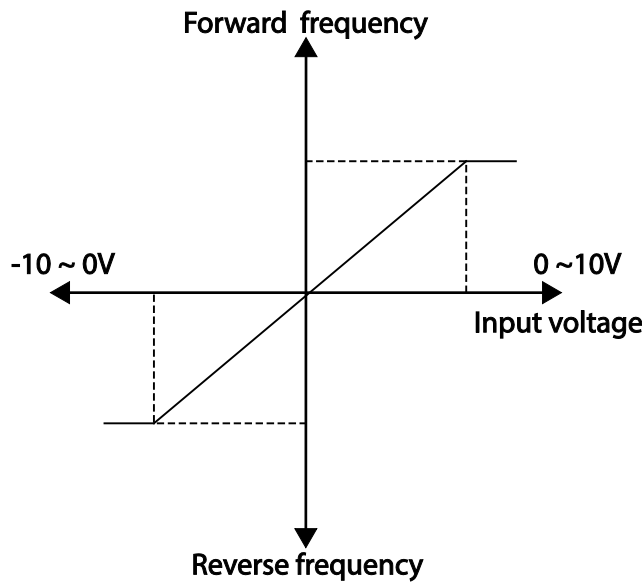

Bipolar input voltage and output frequency

Pr. Group	Pr. Code	Name	Parameter Setting		Setting Range	Unit
Operation	Frq	Frequency reference source	2	V1	0-8	-
In	In.1	Frequency at maximum analog input	60.00		0- Max Frequency	Hz
	In.5	V1 input monitor	0.00		0.00-12.00V	V
	In.6	V1 polarity options	1	Bipolar	0-1	-
	In.12	V1 minimum input voltage	0.00		10.00-0.00V	V
	In.13	V1 output at minimum voltage (%)	0.00		-100.00-0.00%	%
	In.14	V1maximum input voltage	-10.00		-12.00-0.00V	V
	In.15	V1 output at maximum voltage (%)	-100.00		-100.00-0.00%	%

Rotational Directions for Different Voltage Inputs

Command / Voltage Input	Input voltage	
	0-10V	-10-0V
FWD	Forward	Reverse
REV	Reverse	Forward

-10-10V Voltage Input Setting Details

Pr. Code	Description
<p><i>In.12 V1 minimum input voltage</i> <i>In.13 V1 output at minimum voltage (%)</i> <i>In.14 V1 maximum input voltage</i> <i>In.15 V1 output at maximum voltage (%)</i></p>	<p>Sets the gradient level and off-set value of the output frequency in relation to the input voltage. These codes are displayed only when In.6 is set to 1 (bipolar). As an example, if the minimum input voltage (at V1) is set to -2 (V) with 10% output ratio, and the maximum voltage is set to -8 (V) with 80% output ratio respectively, the output frequency will vary within the range of 6 – 48 Hz.</p> <p>For details about the 0-+10V analog inputs, Refer to page 4-47.</p>

Setting a Reference Frequency using Input Current (I2)

You can set and modify a frequency reference using input current at the I2 terminal after selecting current input at SW 2. Set the Frq (Frequency reference source) code in the Operation group to 5 (I2) and apply 4–20 mA input current to I2.

Pr. Group	Pr. Code	Name	Parameter Setting		Setting Range	Unit
Operation	Frq	Frequency reference source	5	I2	0–8	–
In	In.1	Frequency at maximum analog input	60.00		0– Maximum Frequency	Hz
	In.50	I2 input monitor	0.00		0.00–20.00	mA
	In.52	I2 input filter time constant	100		0–10000	ms
	In.53	I2 minimum input current	4.00		0.00–20.00	mA
	In.54	I2 output at minimum current (%)	0.00		0–100	%
	In.55	I2 maximum input current	20.00		0.00–20.00	mA
	In.56	I2 output at maximum current (%)	100.00		0.00–100.00	%
	In.61	I2 rotation direction options	0	No	0–1	–
	In.62	I2 Quantizing level	0.04		0*, 0.04–10.00	%

**Quantizing is disabled if '0' is selected.*

Input Current (I2) Setting Details

Pr. Code	Description
In.1 Freq at 100%	Configures the frequency reference for operation at the maximum current (when In.56 is set to 100%). If In.1 is set to 40.00Hz, and default settings are used for In.53–56, 20mA input current (max) to I2 will produce a frequency reference of 40.00 Hz. If In.56 is set to 50.00 (%), and default settings are used for In.1 (60Hz) and In.53–55, 20mA input current (max) to I2 will produce a frequency reference of 30.00 Hz (50% of 60Hz).
In.50 I2 Monitor	Used to monitor input current at I2.
In.52 I2 Filter	Configures the time for the operation frequency to reach 63% of target frequency based on the input current at I2.
In.53 I2 minimum input current In.54 I2 output at Minimum current (%) In.55 I2 maximum input current In.56 I2 output at maximum current (%)	Configures the gradient level and off-set value of the output frequency. <div style="text-align: center;"> <p>Frequency Reference</p> <p>The graph shows a linear relationship between I2 input and output frequency. The vertical axis represents frequency, and the horizontal axis represents I2 input. A dashed line from the origin passes through a point (In.53, In.54) and another point (In.55, In.56). The line becomes horizontal after In.55. Dashed lines connect the points to their respective values on the axes.</p> </div> <p>[Gradient and off-set configuration based on output frequency]</p>

SETTING A FREQUENCY REFERENCE VIA RS-485 COMMUNICATION

Control the drive with upper-level controllers, such as PCs or PLCs, via RS-485 communication. Set the Frq (Frequency reference source) code in the Operation group to 6 (Int 485) and use the RS-485 signal input terminals (S+/S-) for communication. Refer to "Serial RS-485 Communication Features" on page 5-2.

Pr. Group	Pr. Code	Name	Parameter Setting		Setting Range	Unit
Operation	Frq	Frequency reference source	6	Int 485	0-8	-
CM	CM.1	Integrated RS-485 communication drive ID	-	1	1-250	-
	CM.2	Integrated communication protocol	0	ModBus RTU	0-2	-
			1	Reserved		
			2	Not supported		
	CM.3	Integrated communication speed	3	9600 bps	0-7	-
	CM.4	Integrated communication frame configuration	0	D8/PN/S1	0-3	-
			1	D8/PN/S2		
			2	D8/PE/S1		
3			D8/PO/S1			

FREQUENCY HOLD BY ANALOG INPUT

If you set a frequency reference via analog input at the control terminal block, you can hold the operation frequency of the drive by assigning a multi-function input as the analog frequency hold terminal. The operation frequency will be fixed upon an analog input signal.

Pr. Group	Pr. Code	Name	Parameter Setting		Setting Range	Unit
Operation	Frq	Frequency reference source	0	Keypad-1	0-8	-
			1	Keypad-2		
			2	V1		
			4	V0		
			5	I2		
			6	Int 485		
			8	Fieldbus (Ethernet)		
In	In.65-In.69	Px terminal configuration	21	Analog Hold	0-52	-

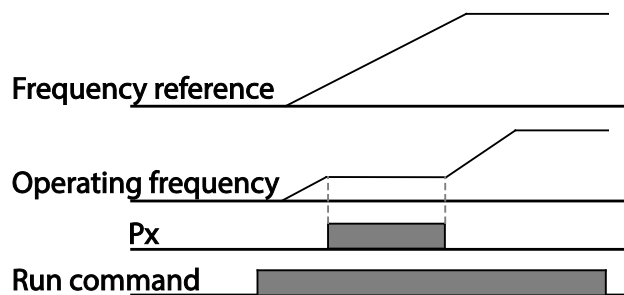

SETTING MULTI-STEP FREQUENCY

Multi-step operations can be carried out by assigning different speeds (or frequencies) to the Px terminals. Step 0 uses the frequency reference source set with the Frq code in the Operation group. Px terminal parameter values 7 (Speed-L), 8 (Speed-M) and 9 (Speed-H) are recognized as binary commands and work in combination with Fx or Rx run commands. The drive operates according to the frequencies set with St1, St2, St3 (multi-step frequency 1-3), bA.53-bA.56 (multi-step frequency 4-7) and the binary command combinations.

Pr. Group	Pr. Code	Name	Parameter Setting	Setting Range	Unit
Operation	St1 St2 St3	Multi-step frequency 1-3	-	0-Maximum frequency	Hz
bA	bA.53 bA.54 bA.55 bA.56	Multi-step frequency 4-7	-	0-Maximum frequency	Hz
In	In.65-In.69	Px terminal configuration	7 Speed-L	0-52	-
			8 Speed-M		-
			9 Speed-H		-
	In.89	Multi-step command delay time	1	1-5000	ms

Multi-step Frequency Setting Details

Pr. Code	Description
Operation group St1-St3	Configure multi-step frequency 1-3.
bA.53-bA.56 Step Freq - 4-7	Configure multi-step frequency 4-7.

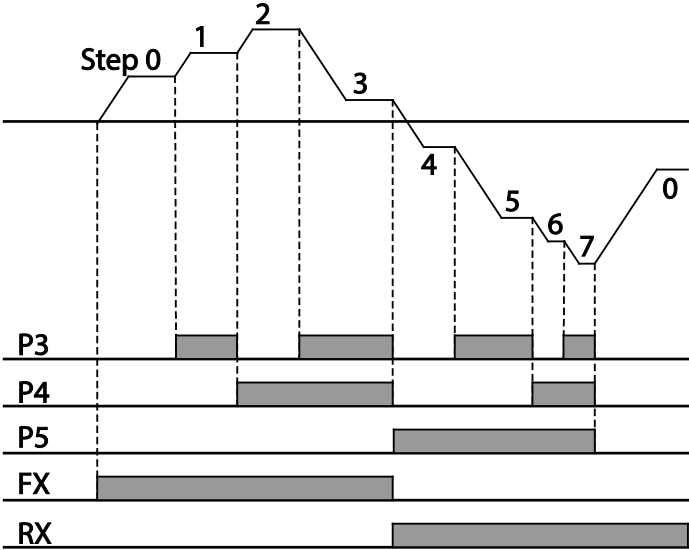
Pr. Code	Description																																													
<p>In.65–In.69 Px Define</p>	<p>Choose the P1–P5 terminals to setup as multi-step inputs, and then set the relevant codes (In.65–69) to 7(Speed–L), 8(Speed–M), or 9(Speed–H).</p> <p>Provided that terminals P3, P4 and P5 have been set to Speed–L, Speed–M and Speed–H respectively, the following multi-step operation will be available.</p>  <p>[An example of a multi-step operation]</p> <table border="1" data-bbox="406 1012 1312 1411"> <thead> <tr> <th>Speed</th> <th>Fx/Rx</th> <th>P5</th> <th>P4</th> <th>P3</th> </tr> </thead> <tbody> <tr> <td>0</td> <td>X</td> <td>–</td> <td>–</td> <td>–</td> </tr> <tr> <td>1</td> <td>X</td> <td>–</td> <td>–</td> <td>X</td> </tr> <tr> <td>2</td> <td>X</td> <td>–</td> <td>X</td> <td>–</td> </tr> <tr> <td>3</td> <td>X</td> <td>–</td> <td>X</td> <td>X</td> </tr> <tr> <td>4</td> <td>X</td> <td>X</td> <td>–</td> <td>–</td> </tr> <tr> <td>5</td> <td>X</td> <td>X</td> <td>–</td> <td>X</td> </tr> <tr> <td>6</td> <td>X</td> <td>X</td> <td>X</td> <td>–</td> </tr> <tr> <td>7</td> <td>X</td> <td>X</td> <td>X</td> <td>X</td> </tr> </tbody> </table>	Speed	Fx/Rx	P5	P4	P3	0	X	–	–	–	1	X	–	–	X	2	X	–	X	–	3	X	–	X	X	4	X	X	–	–	5	X	X	–	X	6	X	X	X	–	7	X	X	X	X
Speed	Fx/Rx	P5	P4	P3																																										
0	X	–	–	–																																										
1	X	–	–	X																																										
2	X	–	X	–																																										
3	X	–	X	X																																										
4	X	X	–	–																																										
5	X	X	–	X																																										
6	X	X	X	–																																										
7	X	X	X	X																																										
<p>In.89 InCheck Time</p>	<p>Set a time interval for the drive to check for additional terminal block inputs after receiving an input signal.</p> <p>After adjusting In.89 to 100ms and an input signal is received at P5, the drive will search for inputs at other terminals for 100ms, before proceeding to accelerate or decelerate based on P5’s configuration.</p>																																													

COMMAND SOURCE CONFIGURATION

Various devices can be selected as command input devices for the ACG drive. Input devices available to select include keypad, multi-function input terminal, RS-485 communication and Fieldbus (Ethernet) adapter.

Pr. Group	Pr. Code	Name	Parameter Setting		Setting Range	Unit
Operation	drv	Command Source	0	Keypad	0-4	-
			1	Fx/Rx-1		
			2	Fx/Rx-2		
			3	Int 485		
			4	Fieldbus (Ethernet)		

THE KEYPAD AS A COMMAND INPUT DEVICE

The keypad can be selected as a command input device to send command signals to the drive. This is configured by setting the drv (command source) code to 0 (Keypad). Press the [RUN] key on the keypad to start an operation, and the [STOP/RESET] key to end it.

Pr. Group	Pr. Code	Name	Parameter Setting		Setting Range	Unit
Operation	drv	Command source	0	Keypad	0-4	-

TERMINAL BLOCK AS A COMMAND INPUT DEVICE (FWD/REV RUN COMMANDS, 2-WIRE)

Multi-function terminals can be selected as a command input device. This is configured by setting the drv (command source) code in the Operation group to 1(Fx/Rx). Select 2 terminals for the forward and reverse operations, and then set the relevant codes (2 of the 5 multi-function terminal codes, In.65–69 for P1–P5) to 1(Fx) and 2(Rx) respectively. This application enables both terminals to be turned on or off at the same time, constituting a stop command that will cause the drive to stop operation.

Pr. Group	Pr. Code	Name	Parameter Setting		Setting Range	Unit
Operation	drv	Command source	1	Fx/Rx-1	0-4	-
In	In.65– In.69	Px terminal configuration	1	Fx	0-52	-
			2	Rx		

Fwd/Rev Command by Multi-function Terminal – Setting Details

Pr. Code	Description
Operation group drv- Cmd Source	Set to 1(Fx/Rx-1).
In.65–In.69 Px Define	Assign a terminal for forward (Fx) operation. Assign a terminal for reverse (Rx) operation.

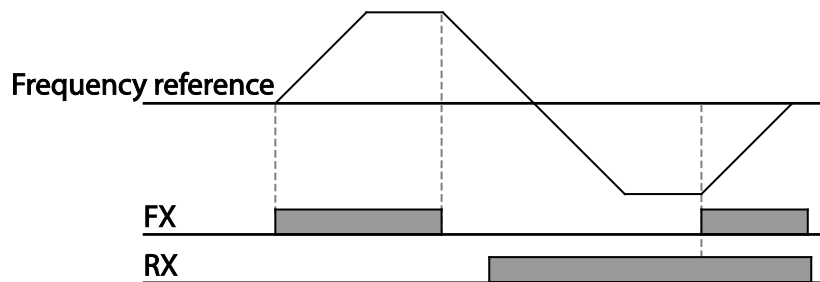

TERMINAL BLOCK AS A COMMAND INPUT DEVICE (RUN AND ROTATION DIRECTION COMMANDS, 2-WIRE)

Multi-function terminals can be selected as a command input device. This is configured by setting the drv (command source) code in the Operation group to 2 (Fx/Rx-2, Run/Direction). Select 2 terminals for run and rotation direction commands, and then select the relevant codes (2 of the 5 multi-function terminal codes, In.65-69 for P1-P5) to 1(Fx) and 2(Rx) respectively. This application uses an Fx input as a run command, and an Rx input to change a motor’s rotation direction (On-Reverse, Off-Forward).

Pr. Group	Pr. Code	Name	Parameter Setting		Setting Range	Unit
Operation	Drv	Command source	2	Fx/Rx-2	0-4	-
In	In.65-In.69	Px terminal configuration	1	Fx	0-52	-
			2	Rx		

Run Command and Fwd/Rev Change Command Using Multi-function Terminal – Setting Details

Pr. Code	Description
Operation group drv Cmd Source	Set to 2(Fx/Rx-2).
In.65-In.69 Px Define	Assign a terminal for run command (Fx). Assign a terminal for changing rotation direction (Rx).

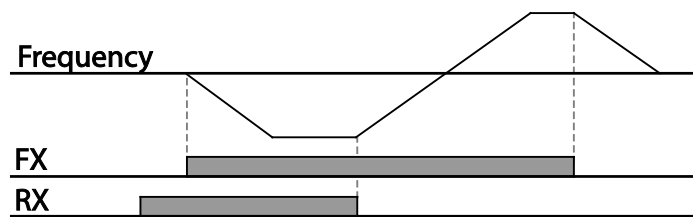

TERMINAL BLOCK AS COMMAND INPUT DEVICE (RUN/STOP, 3-WIRE OPERATION)

The 3-wire operation latches the signal input (the signal stays on after the button is released), and is used when operating the drive with a push button.

Pr. Group	Pr. Code	Name	Parameter Setting		Setting Range	Unit
Operation	drv	Command source	1	Fx/Rx - 1	-	-
In	In.65-In.69	Px terminal configuration	14	3-Wire	0-52	-

To enable the 3-wire operation, the following circuit sequence is necessary. The minimum input time (t) for 3-wire operation is 1ms, and the operation stops when both forward and reverse operation commands are entered at the same time.

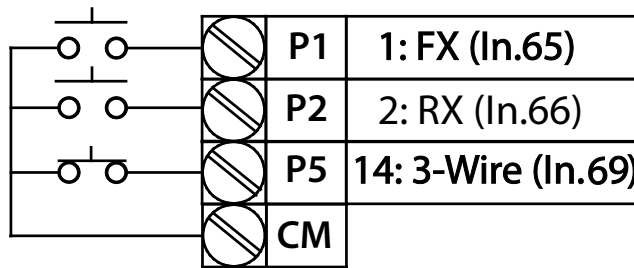

Terminal connections for 3-wire operation

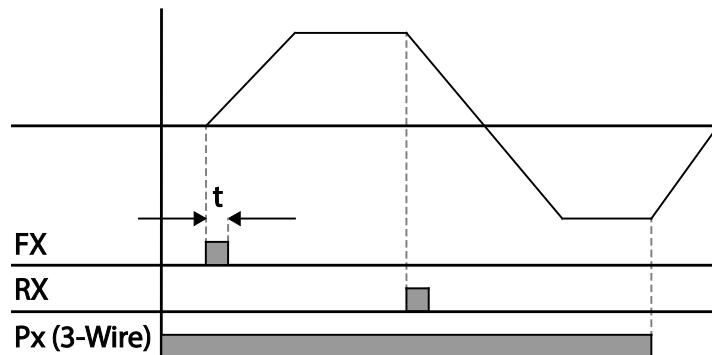

3-wire operation

RS-485 COMMUNICATION AS A COMMAND INPUT DEVICE

Internal RS-485 communication can be selected as a command input device by setting the drv (command source) code in the Operation group to 3(Int 485). This configuration uses upper level controllers such as PCs or PLCs to control the drive by transmitting and receiving signals via the S+ and S- terminals at the terminal block. For more details, refer to "Serial RS-485 Communication Features" on page 5-2.

Pr. Group	Pr. Code	Name	Parameter Setting		Setting Range	Unit
Operation	drv	Command source	3	Int 485	0-4	-
CM	CM.1	Integrated communication drive ID	1		1-250	-
	CM.2	Integrated communication protocol	0	ModBus RTU	0-2	-
	CM.3	Integrated communication speed	3	9600 bps	0-7	-
	CM.4	Integrated communication frame setup	0	D8 / PN / S1	0-3	-

FORWARD OR REVERSE RUN PREVENTION

The rotation direction of motors can be configured to run in only one direction. Setting Ad.9 parameter prevents Parameter drC (operation group) from changing direction.

Pr. Group	Pr. Code	Name	Parameter Setting		Setting Range	Unit
Ad	Ad.9	Run prevention options	0	None	0-2	-
			1	Forward Prev		
			2	Reverse Prev		

Forward/Reverse Run Prevention Setting Details

Pr. Code	Description		
Ad.9 Run Prevent	Choose a direction to prevent.		
	Setting		Description
	0	None	No prevention for Forward or Reverse.
	1	Forward Prev	Set forward run prevention.
	2	Reverse Prev	Set reverse run prevention.

POWER-ON RUN

A power-on run command can be setup to start a drive operation after powering up, based on terminal block operation command being ON. To enable power-on run set the drv (command source) code to 1(Fx/Rx-1 (Fwd Run/Rev Run)) or 2 (Fx/Rx-2 (Run/Direction)) in the Operation group.

Pr. Group	Pr. Code	Name	Parameter Setting	Setting Range	Unit	
Operation	drv	Command source	1, 2	Fx/Rx-1 or Fx/Rx-2	0-4	-
Ad	Ad.10	Power-on run	1	Yes	0-1	-

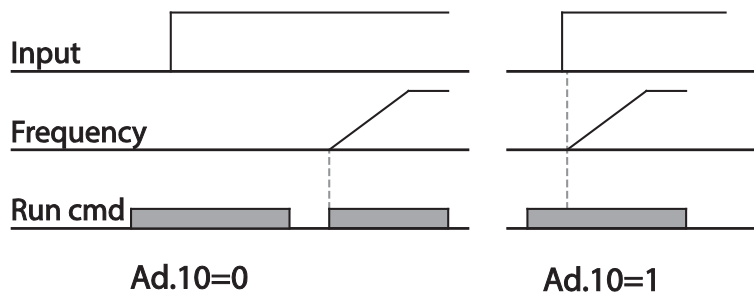
**NOTE:**

- A fault trip may be triggered if the drive starts operation while a motor's load (fan-type load) is in free-run state. To prevent this from happening, set parameter Cn.71 (speed search options), Bit 4 = 1. The drive will perform a speed search at the beginning of the operation.
- If the speed search is not enabled, the drive will begin its operation in a normal V/F pattern and accelerate the motor. If the drive has been turned on without power-on run enabled, the terminal block command must first be turned off, and then turned on again to begin the drive's operation.



CAUTION: USE CAUTION WHEN OPERATING THE DRIVE WITH POWER-ON RUN ENABLED AS THE MOTOR WILL BEGIN ROTATING WHEN THE DRIVE STARTS UP.

RESET AND RESTART

Reset and restart operations can be setup for drive operation following a fault trip, based on the terminal block operation command (if it is configured). When a fault trip occurs, the drive cuts off the output and the motor will free-run. Another fault trip may be triggered if the drive begins its operation while motor load is in a free-run state.

Pr. Group	Pr. Code	Name	Parameter Setting	Setting Range	Unit
Operation	drv	Command source	1 2 Fx/Rx-1 or Fx/Rx-2	0-4	-
Pr	Pr.8	Reset restart setup	1 Yes	0-1	-
	Pr.9	No. of auto restart	0 -	0-10	-
	Pr.10	Auto restart delay time	1.0 -	0-60	sec

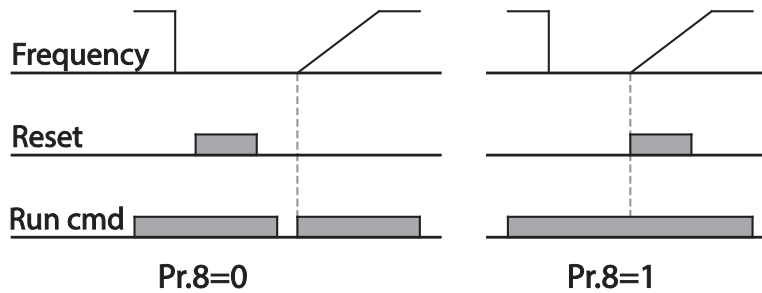

NOTE:



- To prevent a repeat fault trip from occurring, set Cn.71 (speed search options) bit 2 = 1. The drive will perform a speed search at the beginning of the operation.
- If the speed search is not enabled, the drive will start its operation in a normal V/F pattern and accelerate the motor. If the drive has been turned on without 'reset and restart' enabled, the terminal block command must be first turned off, and then turned on again to begin the drive's operation.



CAUTION: Use CAUTION WHEN OPERATING THE DRIVE WITH AUTOMATIC RESTART AFTER RESET ENABLED AS THE MOTOR WILL BEGIN ROTATING AS SOON AS THE DRIVE IS RESET FROM THE TERMINAL BLOCK OR KEYPAD AFTER A TRIP OCCURS.

SETTING ACCELERATION AND DECELERATION TIMES

ACC/DEC TIME BASED ON MAXIMUM FREQUENCY

Acc/Dec time values can be set based on maximum frequency, not on drive operation frequency. To set Acc/Dec time values based on maximum frequency, set bA.8 (Acc/Dec reference), = 0 (Max Freq).

Acceleration time set at the ACC (Acceleration time) code in the Operation group refers to the time required for the drive to reach the maximum frequency from a stopped (0Hz) state. Likewise, the value set at the dEC (deceleration time) parameter in the Operation group refers to the time required to return to a stopped state (0Hz) from the maximum frequency.

Pr. Group	Pr. Code	Name	Parameter Setting		Setting Range	Unit
Operation	ACC	Acceleration time	5.0		0.0–600.0	sec
	dEC	Deceleration time	10.0		0.0–600.0	sec
dr	dr.20	Maximum frequency	60.00		40.00–400.00	Hz
bA	bA.8	Acc/Dec reference frequency	0	Max Freq	0–1	–
	bA.9	Time scale	1	0.1sec	0–2	–

Acc/Dec Time Based on Maximum Frequency – Setting Details

Pr. Code	Description												
bA.8 Ramp T Mode	<p>Set the parameter value to 0 (Max Freq) to setup Acc/Dec time based on maximum frequency.</p> <table border="1"> <thead> <tr> <th colspan="2">Configuration</th> <th>Description</th> </tr> </thead> <tbody> <tr> <td>0</td> <td>Max Freq</td> <td>Set the Acc/Dec time based on maximum frequency.</td> </tr> <tr> <td>1</td> <td>Delta Freq</td> <td>Set the Acc/Dec time based on operating frequency.</td> </tr> </tbody> </table> <p>If, for example, maximum frequency is 60.00Hz, the Acc/Dec times are set to 5 seconds, and the frequency reference for operation is set at 30Hz (half of 60Hz), the time required to reach 30Hz therefore is 2.5 seconds (half of 5 seconds).</p>	Configuration		Description	0	Max Freq	Set the Acc/Dec time based on maximum frequency.	1	Delta Freq	Set the Acc/Dec time based on operating frequency.			
	Configuration		Description										
0	Max Freq	Set the Acc/Dec time based on maximum frequency.											
1	Delta Freq	Set the Acc/Dec time based on operating frequency.											
bA.9 Time scale	<p>Use the time scale for all time-related values. It is particularly useful when a more accurate Acc/Dec times are required because of load characteristics, or when the maximum time range needs to be extended.</p> <table border="1"> <thead> <tr> <th colspan="2">Configuration</th> <th>Description</th> </tr> </thead> <tbody> <tr> <td>0</td> <td>0.01sec</td> <td>Sets 0.01 second as the minimum unit.</td> </tr> <tr> <td>1</td> <td>0.1sec</td> <td>Sets 0.1 second as the minimum unit.</td> </tr> <tr> <td>2</td> <td>1sec</td> <td>Sets 1 second as the minimum unit.</td> </tr> </tbody> </table>	Configuration		Description	0	0.01sec	Sets 0.01 second as the minimum unit.	1	0.1sec	Sets 0.1 second as the minimum unit.	2	1sec	Sets 1 second as the minimum unit.
Configuration		Description											
0	0.01sec	Sets 0.01 second as the minimum unit.											
1	0.1sec	Sets 0.1 second as the minimum unit.											
2	1sec	Sets 1 second as the minimum unit.											



CAUTION: NOTE THAT THE RANGE OF MAXIMUM TIME VALUES MAY CHANGE AUTOMATICALLY WHEN THE UNITS ARE CHANGED. IF FOR EXAMPLE, THE ACCELERATION TIME IS SET AT 6000 SECONDS, A TIME SCALE CHANGE FROM 1 SECOND TO 0.01 SECOND WILL RESULT IN A MODIFIED ACCELERATION TIME OF 60.00 SECONDS.

ACC/DEC TIME BASED ON OPERATION FREQUENCY

Acc/Dec times can be set based on the time required to reach the next step frequency from the existing operation frequency. To set the Acc/Dec time values based on the existing operation frequency, set bA.08 (acc/dec reference),= 1 (Delta Freq).

Pr. Group	Pr. Code	Name	Parameter Setting	Setting Range	Unit
Operation	ACC	Acceleration time	20.0	0.0–600.0	sec
	dEC	Deceleration time	30.0	0.0–600.0	sec
bA	bA.8	Acc/Dec reference	1	Delta Freq	0–1

Acc/Dec Time Based on Operation Frequency – Setting Details

Pr. Code	Description									
bA.8 <i>Ramp T Mode</i>	Set the parameter value to 1 (Delta Freq) to set Acc/Dec times based on Maximum frequency.									
	<table border="1"> <thead> <tr> <th colspan="2">Configuration</th> <th>Description</th> </tr> </thead> <tbody> <tr> <td>0</td> <td>Max Freq</td> <td>Set the Acc/Dec time based on Maximum frequency</td> </tr> <tr> <td>1</td> <td>Delta Freq</td> <td>Set the Acc/Dec time based on Operation Frequency</td> </tr> </tbody> </table>	Configuration		Description	0	Max Freq	Set the Acc/Dec time based on Maximum frequency	1	Delta Freq	Set the Acc/Dec time based on Operation Frequency
	Configuration		Description							
	0	Max Freq	Set the Acc/Dec time based on Maximum frequency							
1	Delta Freq	Set the Acc/Dec time based on Operation Frequency								
If Acc/Dec times are set to 5 seconds, and multiple frequency references are used in the operation in 2 steps, at 10Hz and 30 Hz, each acceleration stage will take 5 seconds (refer to the graph).										

MULTI-STEP ACC/DEC TIME CONFIGURATION

Acc/Dec times can be configured via a multi-function terminal by setting the ACC (acceleration time) and dEC (deceleration time) codes in the Operation group.

Pr. Group	Pr. Code	Name	Parameter Setting	Setting Range	Unit	
Operation	ACC	Acceleration time	5.0	0.0–600.0	sec	
	dEC	Deceleration time	10.0	0.0–600.0	sec	
bA	bA.70–bA.83	Multi-step acceleration and deceleration time 1–7	0.0	0.0–600.0	sec	
In	In.65–In.69	Px terminal configuration	11	XCEL–L	0–52	–
			12	XCEL–M		
			49	XCEL–H		
	In.89	Multi-step command delay time	1	1–5000	ms	

Acc/Dec Time Setup via Multi-function Terminals – Setting Details

Pr. Code	Description		
bA.70, bA.72, bA.74, bA.76, bA.78, bA.80, bA.82 Acc Time 1-7	Set multi-step acceleration time 1-7.		
bA.71, bA.73, bA.75, bA.77, bA.79, bA.81, bA.83 Dec Time 1-7	Set multi-step deceleration time 1-7.		
In.65-In.69 Px Define (P1-P5)	Choose and configure the terminals to use for multi-step Acc/Dec time inputs.		
	Configuration		
	11	XCEL-L	Acc/Dec command-L
	12	XCEL-M	Acc/Dec command-M
	49	XCEL-H	Acc/Dec command-H
	Acc/Dec commands are recognized as binary code inputs and will control the acceleration and deceleration based on parameter values set with bA.70-bA.83. If, for example, the P4 and P5 terminals are set as XCEL-L and XCEL-M respectively, the following operation will be available.		
	Acc/Dec time	P5	P4
	0	-	-
	1	-	X
2	X	-	
3	X	X	
In.89 In Check Time	Set the time for the drive to check for other terminal block inputs. If In.89 is set to 100ms and a signal is supplied to the P4 terminal, the drive searches for other inputs over the next 100ms. When the time expires, the Acc/Dec time will be set based on the input received at P4.		

CONFIGURING ACC/DEC TIME SWITCH FREQUENCY

You can switch between two different sets of Acc/Dec times (Acc/Dec gradients) by configuring the switch frequency without configuring the multi-function terminals.

Pr. Group	Pr. Code	Name	Parameter Setting	Setting Range	Unit
Operation	ACC	Acceleration time	5.0	0.0-600.0	sec
	dEC	Deceleration time	10.0	0.0-600.0	sec
bA	bA.70	Multi-step acceleration time 1	20.0	0.0-600.0	sec
	bA.71	Multi-step deceleration time 1	20.0	0.0-600.0	sec
Ad	Ad.60	Acc/Dec time switch frequency	30.00	0-Maximum frequency	Hz

Acc/Dec Time Switch Frequency Setting Details

Pr. Code	Description
<p>Ad.60 Xcel Change Fr</p>	<p>After the Acc/Dec switch frequency has been set, Acc/Dec gradients configured at bA.70 and bA.71 will be used when the drive's operation frequency is at or below the switch frequency. If the operation frequency exceeds the switch frequency, the configured gradient level, configured for the ACC and dEC codes, will be used.</p> <p>If you configure the P1–P5 multi-function input terminals for multi-step Acc/Dec gradients (XCEL–L, XCEL–M, XCEL–H), the drive will operate based on the Acc/Dec inputs at the terminals instead of the Acc/Dec switch frequency configurations.</p>

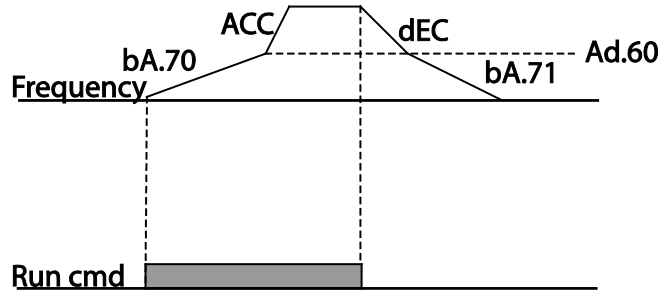

ACC/DEC PATTERN CONFIGURATION

Acc/Dec gradient level patterns can be configured to enhance and smooth the drive’s acceleration and deceleration curves. Linear pattern features a linear increase or decrease to the output frequency, at a fixed rate. For an S-curve pattern a smoother and more gradual increase or decrease of output frequency, ideal for lift-type loads or elevator doors, etc. S-curve gradient level can be adjusted using codes Ad.3–Ad.6 in the Advanced group.

Pr. Group	Pr. Code	Name	Parameter Setting		Setting Range	Unit
bA	bA.8	Acc/Dec reference	0	Max Freq	0–1	–
Ad	Ad.1	Acceleration pattern	0	Linear	0–1	–
	Ad.2	Deceleration pattern	1	S-curve		–
	Ad.3	S-curve Acc start gradient	40		1–100	%
	Ad.4	S-curve Acc end gradient	40		1–100	%
	Ad.5	S-curve Dec start gradient	40		1–100	%
	Ad.6	S-curve Dec end gradient	40		1–100	%

Acc/Dec Pattern Setting Details

Pr. Code	Description
Ad.3 Acc S Start	Sets the gradient level as acceleration starts when using an S-curve, Acc/Dec pattern. Ad.3 defines S-curve gradient level as a percentage, up to half of total acceleration. If the frequency reference and maximum frequency are set at 60Hz and Ad.3 is set to 50%, Ad.3 configures acceleration up to 30Hz (half of 60Hz).The drive will operate S-curve acceleration in the 0–15 Hz frequency range (50% of 30Hz). Linear acceleration will be applied to the remaining acceleration within the 15–30 Hz frequency range.
Ad.4 Acc S End	Sets the gradient level as acceleration ends when using an S-curve Acc/Dec pattern. Ad.3 defines S-curve gradient level as a percentage, above half of total acceleration. If the frequency reference and the maximum frequency are set at 60Hz and Ad.4 is set to 50%, setting Ad.4 configures acceleration to increase from 30Hz (half of 60Hz) to 60Hz (end of acceleration). Linear acceleration will be applied within the 30–45 Hz frequency range. The drive will perform an S-curve acceleration for the remaining acceleration in the 45–60 Hz frequency range.
Ad.5 Dec S Start – Ad.6 Dec S End	Sets the rate of S-curve deceleration. Configuration for codes Ad.5 and Ad.6 may be performed the same way as configuring codes Ad.3 and Ad.4.

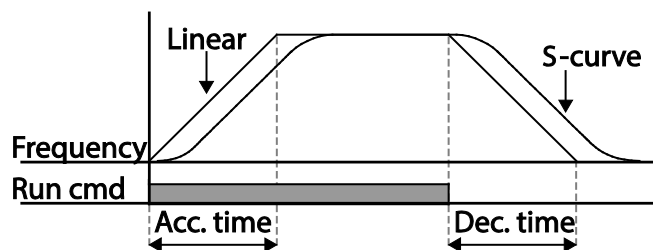

Acceleration / deceleration pattern configuration

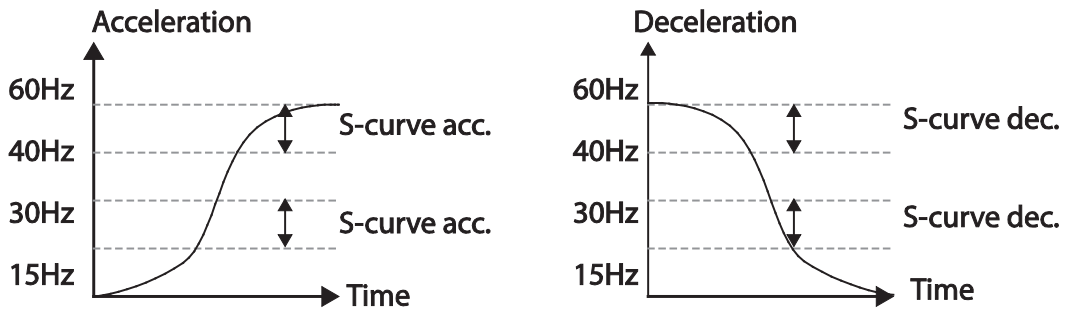
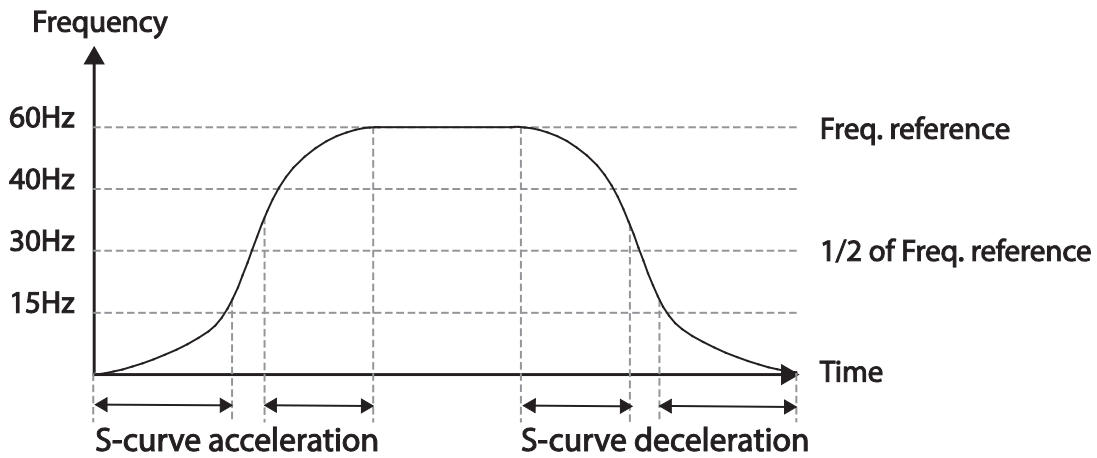

Acceleration / deceleration S-curve pattern configuration

NOTE:

The Actual Acc/Dec time during an S-curve application:



- Actual acceleration time = user-configured acceleration time + user-configured acceleration time x starting gradient level/2 + user-configured acceleration time x ending gradient level/2.
- Actual deceleration time = user-configured deceleration time + user-configured deceleration time x starting gradient level/2 + user-configured deceleration time x ending gradient level/2



CAUTION: NOTE THAT ACTUAL ACC/DEC TIMES BECOME GREATER THAN USER DEFINED ACC/DEC TIMES WHEN S-CURVE ACC/DEC PATTERNS ARE IN USE.

STOPPING THE ACC/DEC OPERATION

Configure the multi-function input terminals to stop acceleration or deceleration and operate the drive at a fixed frequency.

Pr. Group	Pr. Code	Name	Parameter Setting		Setting Range	Unit
In	In.65–In.69	Px terminal configuration	25	XCEL Stop	0–52	–

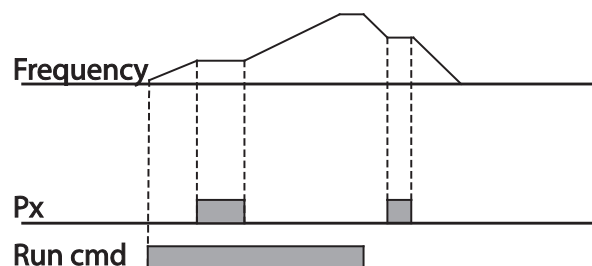

V/F (VOLTAGE/FREQUENCY) CONTROL

Configure the drive’s output voltages, gradient levels and output patterns to achieve a target output frequency with V/F control. The amount of torque boost used during low frequency operations can also be adjusted.

LINEAR V/F PATTERN OPERATION

A linear V/F pattern configures the drive to increase or decrease the output voltage at a fixed rate for different operation frequencies based on V/F characteristics. A linear V/F pattern is particularly useful when a constant torque load is applied.

Pr. Group	Pr. Code	Name	Parameter Setting		Setting Range	Unit
dr	dr.9	Control mode	0	V/F	0–4	–
	dr.18	Base frequency	60.00		30.00–400.00	Hz
	dr.19	Start frequency	0.50		0.01–10.00	Hz
bA	bA.7	V/F pattern	0	Linear	0–3	–

Linear V/F Pattern Setting Details

Pr. Code	Description
dr.18 Base Freq	Sets the base frequency. A base frequency is the drive’s output frequency when running at its rated voltage. Refer to the motor’s rating plate to set this parameter value.
dr.19 Start Freq	<p>Sets the start frequency. A start frequency is a frequency at which the drive starts voltage output. The drive does not produce output voltage while the frequency reference is lower than the set frequency. However, if a deceleration stop is made while operating above the start frequency, output voltage will continue until the operation frequency reaches a full-stop (0Hz).</p>

SQUARE REDUCTION V/F PATTERN OPERATION

Square reduction V/F pattern is ideal for loads such as fans and pumps. It provides non-linear acceleration and deceleration patterns to sustain torque throughout the whole frequency range.

Pr. Group	Pr. Code	Name	Parameter Setting		Setting Range	Unit
bA	bA.7	V/F pattern	1	Square	0-3	-
			3	Square2		

Square Reduction V/F pattern Operation – Setting Details

Pr. Code	Description		
bA.7 V/F Pattern	Sets the parameter value to 1(Square) or 3(Square2) according to the load’s start characteristics.		
	Setting		Function
	1	Square	The drive produces output voltage proportional to 1.5 square of the operation frequency.
	3	Square2	The drive produces output voltage proportional to 2 square of the operation frequency. This setup is ideal for variable torque loads such as fans or pumps.

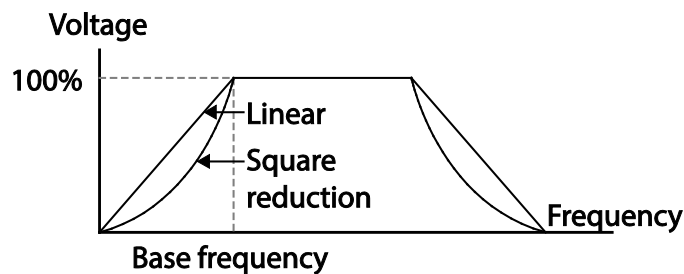

USER V/F PATTERN OPERATION

The ACG drive allows the configuration of user-defined V/F patterns to suit the load characteristics of special motors.

Pr. Group	Pr. Code	Name	Parameter Setting		Setting Range	Unit
bA	bA.7	V/F pattern	2	User V/F	0-3	-
	bA.41	User Frequency1	15.00		0-Maximum frequency	Hz
	bA.42	User Voltage1	25		0-100	%
	bA.43	User Frequency2	30.00		0-Maximum frequency	Hz
	bA.44	User Voltage2	50		0-100	%
	bA.45	User Frequency3	45.00		0-Maximum frequency	Hz
	bA.46	User Voltage3	75		0-100	%
	bA.47	User Frequency4	Maximum frequency		0-Maximum frequency	Hz
	bA.48	User Voltage4	100		0-100%	%

User V/F pattern Setting Details

Pr. Code	Description
bA.41 User Freq 1- bA.48 User Volt 4	Set the parameter values to assign arbitrary frequencies (User Freq 1-4) for start and maximum frequencies. Voltages can also be set to correspond with each frequency, and for each user voltage (User Volt 1-4).

The 100% output voltage in the figure below is based on the parameter settings of bA.15 (motor rated voltage). If bA.15 is set to 0 it will be based on the input voltage.

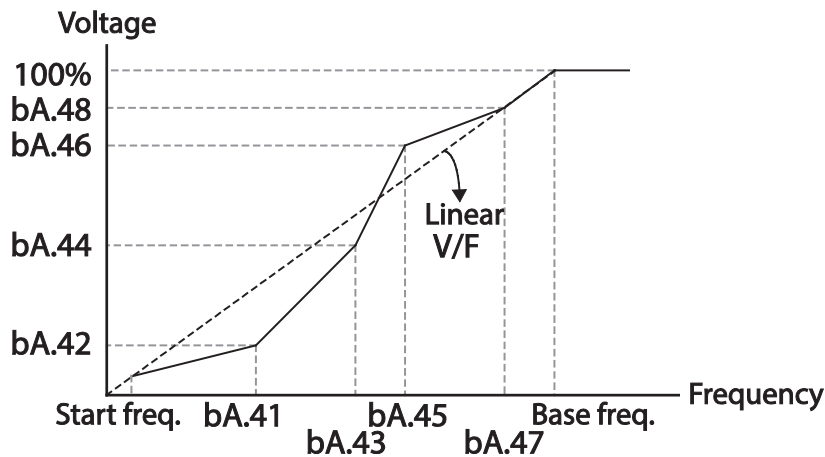

CAUTION: WHEN A NORMAL INDUCTION MOTOR IS IN USE, CARE MUST BE TAKEN NOT TO CONFIGURE THE OUTPUT PATTERN AWAY FROM A LINEAR V/F PATTERN. NON-LINEAR V/F PATTERNS MAY CAUSE INSUFFICIENT MOTOR TORQUE OR MOTOR OVERHEATING DUE TO OVER-EXCITATION. WHEN A USER V/F PATTERN IS IN USE, FORWARD TORQUE BOOST (DR. 16) AND REVERSE TORQUE BOOST (DR. 17) DO NOT OPERATE.

TORQUE BOOST

MANUAL TORQUE BOOST

Manual torque boost enables users to adjust output voltage during low speed operation or motor start. Increase low speed torque or improve motor starting properties by manually increasing output voltage. Configure manual torque boost while running loads that require high starting torque, such as lift-type loads.

Pr. Group	Pr. Code	Name	Parameter Setting		Setting Range	Unit
dr	dr.15	Torque boost options	0	Manual	0-1	-
	dr.16	Forward torque boost	2.0		0.0-15.0	%
	dr.17	Reverse torque boost	2.0		0.0-15.0	%

Manual Torque Boost Setting Details

Pr. Code	Description
dr.16 Fwd Boost	Set torque boost for forward operation.
dr.17 Rev Boost	Set torque boost for reverse operation.

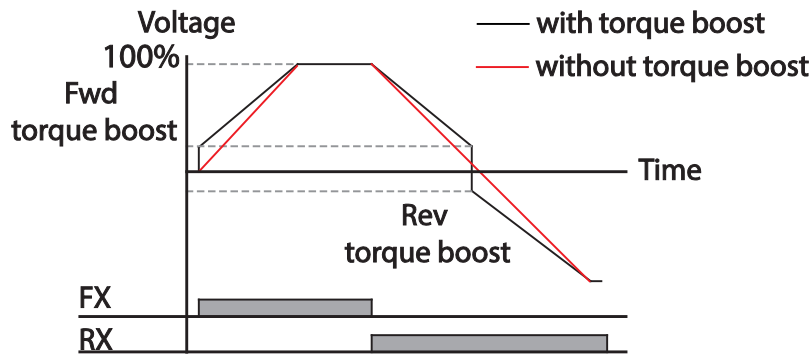

CAUTION: EXCESSIVE TORQUE BOOST WILL RESULT IN OVER-EXCITATION AND MOTOR OVERHEATING

AUTO TORQUE BOOST

In V/F operation, this adjusts the output voltage if operation is unavailable due to a low output voltage. It is used when operation is unavailable, due to a lack of starting torque, by providing a voltage boost to the output voltage via the torque current.

Pr. Group	Pr. Code	Name	Parameter Setting		Setting Range	Unit
dr	dr.15	Torque boost mode	1	Auto	0–1	–
	dr.26	Auto torque boost filter gain	2		1–1000	–
	dr.27	Auto torque boost motoring voltage gain	50.0		0.0–300.0	%
	dr.28	Auto torque boost regeneration voltage gain	50.0		0.0–300.0	%

You can use the parameter value displayed on the motor's rating plate without motor parameter tuning. Use after entering the value recorded on the motor's rating plate in dr.18 (base frequency), bA.12 (motor's rated slip frequency), bA.13 (motor's rated current), and bA.14 (motor's no load current). If you do not use the value displayed on the motor's rating plate, each parameter value is set to the initial value and some features may be limited.

In V/F operation, this adjusts the output voltage if operation is unavailable due to a low output voltage. Use when it cannot be started due to the lack of the starting torque as a method to output voltage by adding the voltage boost quantity calculated by using torque current on the manual torque boost quantity (dr.16, dr.17). If the run direction is forward, dr.16 forward torque boost quantity is applied. If the direction is reverse, dr.17 reverse torque boost quantity is applied. As the values to adjust the amount of compensation according to the load, dr.27 and dr.28 automatic torque boost voltage gain can be adjusted and used when there is a lack of starting torque or when excessive current is flowing.

If automatic torque boost is selected (dr.15=1), parameter codes dr.26, dr.27, and dr.28 are enabled and the drive outputs voltage according to the torque boost quantity.

OUTPUT VOLTAGE SETTING

Output voltage settings are required when a motor's rated voltage differs from the input voltage to the drive. Set bA.15 to configure the motor's rated operating voltage. The set voltage becomes the output voltage of the drive's base frequency. When the drive operates above the base frequency, and when the motor's voltage rating is lower than the input voltage at the drive, the drive adjusts the voltage and supplies the motor with the voltage set at bA.15 (motor rated voltage). If the motor's rated voltage is higher than the input voltage at the drive, the drive will supply the drive input voltage to the motor.

If bA.15 (motor rated voltage) is set to 0, the drive corrects the output voltage based on the input voltage in the stopped condition. If the frequency is higher than the base frequency, when the input voltage is lower than the parameter setting, the input voltage will be the drive output voltage.

Pr. Group	Pr. Code	Name	Parameter Setting	Setting Range	Unit
bA	bA.15	Motor rated voltage	0	0, 100–480	V

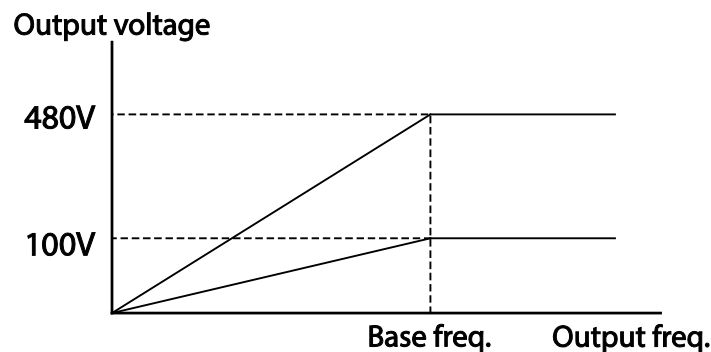

START MODE SETTING

Select the start mode to use when the operation command is input with the motor in the stopped condition.

ACCELERATION START

Acceleration start is a general acceleration mode. If there are no extra settings applied, the motor accelerates directly to the frequency reference when the command is input.

Pr. Group	Pr. Code	Name	Parameter Setting	Setting Range	Unit
Ad	Ad.7	Start mode	0 Acc	0–1	–

DC BRAKING AFTER START

This start mode supplies a DC voltage for a set amount of time to provide DC braking before the drive starts to accelerate a motor. If the motor continues to rotate due to its inertia, DC braking will stop the motor, allowing the motor to accelerate from a stopped condition. DC braking can also be used with a mechanical brake connected to a motor shaft when a constant torque load is applied, if a constant torque is required after the mechanical brake is released.

Pr. Group	Pr. Code	Name	Parameter Setting		Setting Range	Unit
Ad	Ad.7	Start mode	1	DC-Start	0-1	-
	Ad.12	Start DC braking time	0.00		0.00-60.00	sec
	Ad.13	DC Injection Level	50		0-Rated Current of Drive/Rated Current of Motor x 100%	%

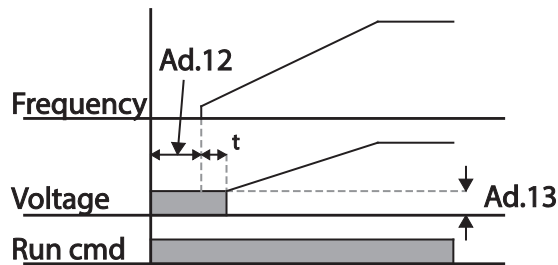

CAUTION: THE AMOUNT OF DC BRAKING REQUIRED IS BASED ON THE MOTOR'S RATED CURRENT. DO NOT USE DC BRAKING RESISTANCE VALUES THAT CAN CAUSE CURRENT DRAW TO EXCEED THE RATED CURRENT OF THE DRIVE. IF THE DC BRAKING RESISTANCE IS TOO HIGH OR BRAKE TIME IS TOO LONG, THE MOTOR MAY OVERHEAT OR BE DAMAGED.

PRE-EXCITE OF STOP STATUS

Use to apply the fluxa current to the motor under a stop status. If you enter the multi-function input signal set with the initial excitation signal, DC voltage will be supplied to the motor.

Pr. Group	Pr. Code	Name	Parameter Setting		Setting Range	Unit
Ad	Ad.13	Amount of applied DC	50		0-Rated Current of Drive/Rated Current of Motor x 100%	%
In	In.65-In.69	Px terminal setting options	34	Pre excite	-	-



CAUTION: THE AMOUNT OF DC BRAKING REQUIRED IS BASED ON THE MOTOR'S RATED CURRENT. DO NOT USE DC BRAKING RESISTANCE VALUES THAT CAN CAUSE CURRENT DRAW TO EXCEED THE RATED CURRENT OF THE DRIVE. IF THE DC BRAKING RESISTANCE IS TOO HIGH OR BRAKE TIME IS TOO LONG, THE MOTOR MAY OVERHEAT OR BE DAMAGED.

STOP MODE SETTING

Select a stop mode to stop the drive operation.

DECELERATION STOP

Deceleration stop is a general stop mode. If there are no extra settings applied, the motor decelerates down to 0Hz and stops, as shown in the figure below.

Pr. Group	Pr. Code	Name	Parameter Setting		Setting Range	Unit
Ad	Ad.8	Stop mode	0	Dec	0-4	-

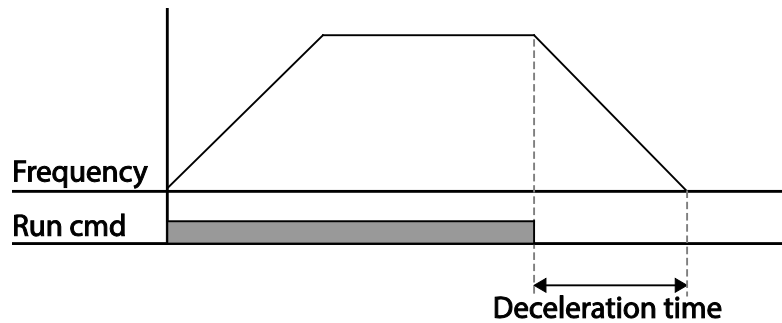

STOP AFTER DC BRAKING

When the operation frequency reaches the set value during deceleration (DC braking frequency), the drive stops the motor by supplying DC power to the motor. With a stop command input, the drive begins decelerating the motor. When the frequency reaches the DC braking frequency set at Ad.17, the drive supplies DC voltage to the motor and stops it.

Pr. Group	Pr. Code	Name	Parameter Setting		Setting Range	Unit
Ad	Ad.8	Stop mode	0	Dec	0–4	–
	Ad.14	Output block time before braking	0.10		0.00–60.00	sec
	Ad.15	DC braking time	1.00		0–60	sec
	Ad.16	DC braking amount	50		0–Rated Current of Drive/Rated Current of Motor x 100%	%
	Ad.17	DC braking frequency	5.00		0.00–60.00	Hz

DC Braking After Stop Setting Details

Pr. Code	Description
Ad.14 DC-Block Time	Set the time to block the drive output before DC braking. If the inertia of the load is great, or if DC braking frequency (Ad.17) is set too high, a fault trip may occur due to overcurrent conditions when the drive supplies DC voltage to the motor. Prevent overcurrent fault trips by adjusting the output block time before DC braking.
Ad.15 DC-Brake Time	Set the time duration for the DC voltage supply to the motor.
Ad.16 DC-Brake Level	Set the amount of DC braking to apply. The parameter setting is based on the rated current of the motor. The maximum value of the DC braking rate is limited as an drive rated current. Maximum Value of Dc-Brake Level = Rated Current of Drive/Rated Current of Motor x 100%.
Ad.17 DC-Brake Freq	Set the frequency to start DC braking. When the frequency is reached, the drive starts deceleration. If the dwell frequency is set lower than the DC braking frequency, dwell operation will not work and DC braking will start instead.

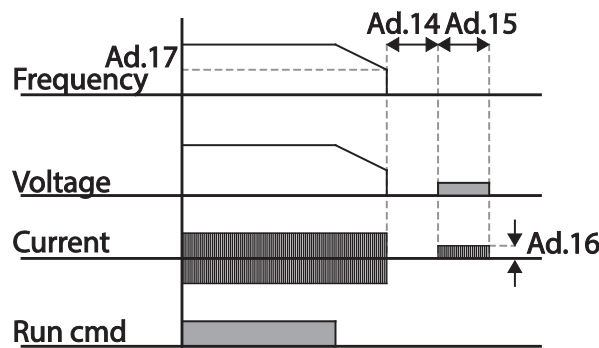

CAUTION: NOTE THAT THE MOTOR CAN OVERHEAT OR BE DAMAGED IF EXCESSIVE AMOUNT OF DC BRAKING IS APPLIED TO THE MOTOR, OR DC BRAKING TIME IS SET TOO LONG.
DC BRAKING IS CONFIGURED BASED ON THE MOTOR'S RATED CURRENT. TO PREVENT OVERHEATING OR DAMAGING MOTORS, DO NOT SET THE CURRENT VALUE HIGHER THAN THE DRIVE'S RATED CURRENT.

FREE RUN STOP

When the Operation command is off, the drive output turns off, and the load stops due to residual inertia.

Pr. Group	Pr. Code	Name	Parameter Setting		Setting Range	Unit
Ad	Ad.8	Stop Method	2	Free-Run	0-4	-

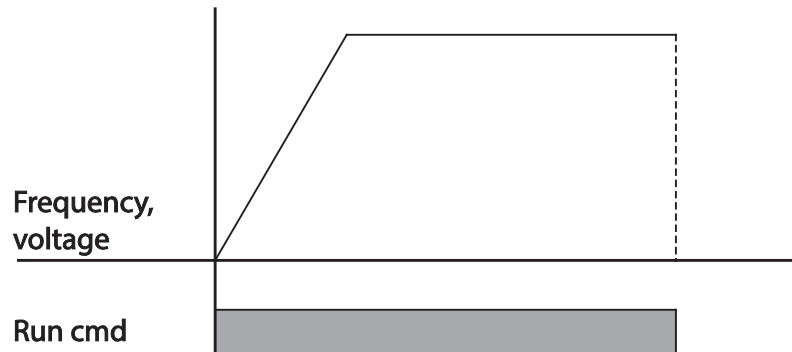

CAUTION: NOTE THAT WHEN THERE IS HIGH INERTIA ON THE OUTPUT SIDE AND THE MOTOR IS OPERATING AT HIGH SPEED, THE LOAD'S INERTIA WILL CAUSE THE MOTOR TO CONTINUE ROTATING EVEN IF THE DRIVE OUTPUT IS BLOCKED.

POWER BRAKING

When the drive's DC voltage rises above a specified level due to motor regenerated energy, a control is made to either adjust the deceleration gradient level or reaccelerate the motor in order to reduce the regenerated energy. Power braking can be used when short deceleration times are needed without brake resistors, or when optimum deceleration is needed without causing an over voltage fault trip.

Pr. Group	Pr. Code	Name	Parameter Setting		Setting Range	Unit
Ad	Ad.8	Stop mode	4	Power Braking	0-4	-

**CAUTION:**

- TO PREVENT OVERHEATING OR DAMAGING THE MOTOR, DO NOT APPLY POWER BRAKING TO THE LOADS THAT REQUIRE FREQUENT DECELERATION.
- STALL PREVENTION AND POWER BRAKING ONLY OPERATE DURING DECELERATION, AND POWER BRAKING TAKES PRIORITY OVER STALL PREVENTION. IN OTHER WORDS, WHEN BOTH Pr.50 (STALL PREVENTION AND FLUX BRAKING) AND Ad.8 (POWER BRAKING) ARE SET, POWER BRAKING WILL TAKE PRECEDENCE AND OPERATE.
- NOTE THAT IF DECELERATION TIME IS TOO SHORT OR INERTIA OF THE LOAD IS TOO GREAT, AN OVERVOLTAGE FAULT TRIP MAY OCCUR.
- NOTE THAT IF A FREE RUN STOP IS USED, THE ACTUAL DECELERATION TIME CAN BE LONGER THAN THE PRE-SET DECELERATION TIME.

FREQUENCY LIMIT

Operation frequency can be limited by setting maximum frequency, start frequency, upper limit frequency and lower limit frequency.

FREQUENCY LIMIT USING MAXIMUM FREQUENCY AND START FREQUENCY

Pr. Group	Pr. Code	Name	Parameter Setting	Setting Range	Unit
dr	dr.19	Start frequency	0.50	0.01–10.00	Hz
	dr.20	Maximum frequency	60.00	40.00–400.00	Hz

Frequency Limit Using Maximum Frequency and Start Frequency – Setting Details

Pr. Code	Description
dr.19 Start Freq	Set the lower limit value for speed unit parameters that are expressed in Hz or rpm. If an input frequency is lower than the start frequency, the parameter value will be 0.00.
dr.20 Max Freq	Set an upper limit frequency to all speed unit parameters that are expressed in Hz or rpm, except for the base frequency (dr.18). Frequency cannot be set higher than the upper limit frequency.

FREQUENCY LIMIT USING UPPER AND LOWER LIMIT FREQUENCY VALUES

Pr. Group	Pr. Code	Name	Parameter Setting	Setting Range	Unit
Ad	Ad.24	Frequency limit	0 No	0–1	–
	Ad.25	Frequency lower limit value	0.50	0.0–maximum frequency	Hz
	Ad.26	Frequency upper limit value	Maximum frequency	minimum–maximum frequency	Hz

Frequency Limit Using Upper and Lower Limit Frequencies – Setting Details

Pr. Code	Description
Ad.24 Freq Limit	The initial setting is 0(No). Changing the setting to 1(Yes) allows the setting of frequencies between the lower limit frequency (Ad.25) and the upper limit frequency (Ad.26). When the setting is 0(No), codes Ad.25 and Ad.26 are not visible.
Ad.25 Freq Limit Lo, Ad.26 Freq Limit Hi	Set upper and lower frequency limits. All frequency selections are restricted to frequencies from within the upper and lower limits. This restriction also applies when you in input a frequency reference using the keypad.

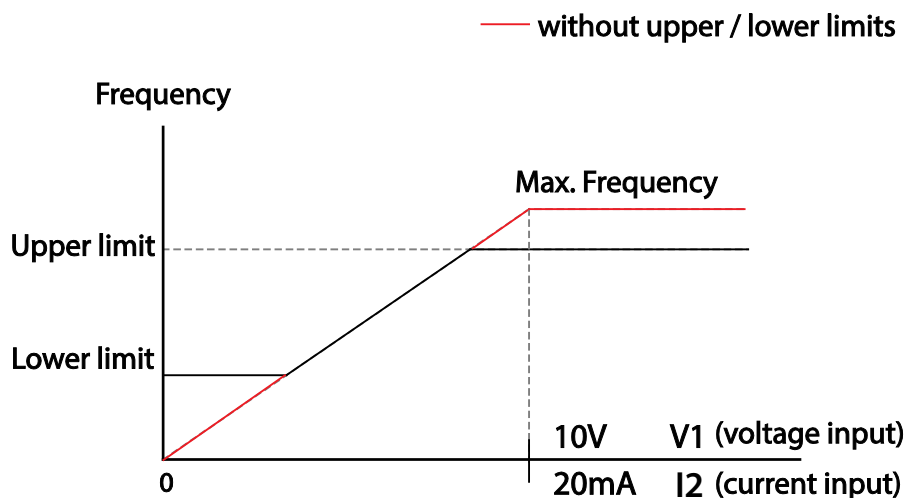

FREQUENCY JUMP

Use frequency jump to avoid mechanical resonance frequencies. Jump through frequency bands when a motor accelerates and decelerates. Operation frequencies cannot be set within the pre-set frequency jump band.

When a frequency setting is increased, while the frequency parameter setting value (voltage, current, RS-485 communication, keypad setting, etc.) is within a jump frequency band, the frequency will be maintained at the lower limit value of the frequency band. Then, the frequency will increase when the frequency parameter setting exceeds the range of frequencies used by the frequency jump band.

Pr. Group	Pr. Code	Name	Parameter Setting	Setting Range	Unit
Ad	Ad.27	Frequency jump	0 No	0-1	-
	Ad.28	Jump frequency lower limit1	10.00	0.00-Jump frequency upper limit 1	Hz
	Ad.29	Jump frequency upper limit1	15.00	Jump frequency lower limit 1-Maximum frequency	Hz
	Ad.30	Jump frequency lower limit 2	20.00	0.00-Jump frequency upper limit 2	Hz
	Ad.31	Jump frequency upper limit 2	25.00	Jump frequency lower limit 2-Maximum frequency	Hz
	Ad.32	Jump frequency lower limit 3	30.00	0.00-Jump frequency upper limit 3	Hz
	Ad.33	Jump frequency upper limit 3	35.00	Jump frequency lower limit 3-Maximum frequency	Hz

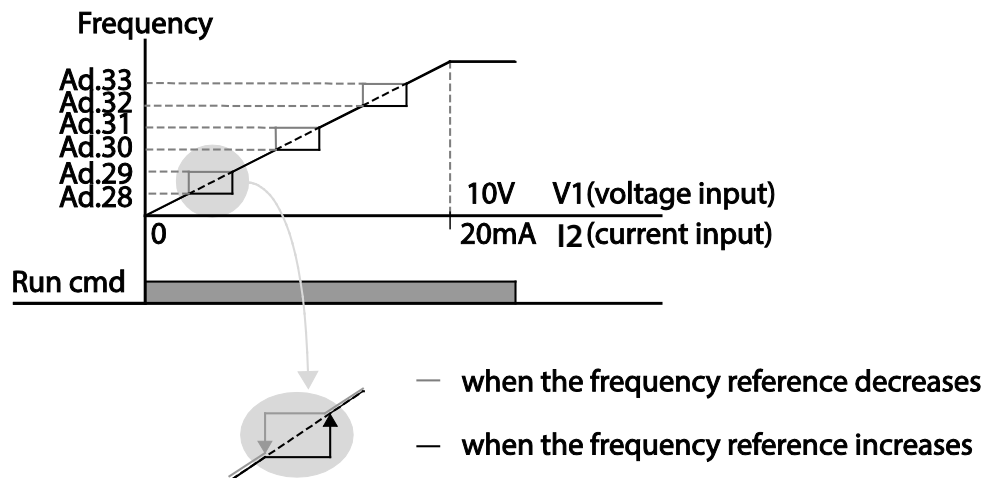

2ND OPERATION MODE SETTING

Apply two types of operation modes and switch between them as required. For both the first and second command source, set the frequency after shifting operation commands to the multi-function input terminal. Mode switching can be used to stop remote control during an operation using the communication option and to switch operation mode to operate via the local panel, or to operate the drive from another remote control location.

Select one of the multi-function terminals from codes In.65–In.69 and set the parameter value to 15 (2nd Source).

Pr. Group	Pr. Code	Name	Parameter Setting	Setting Range	Unit	
Operation	drv	Command source	1	Fx/Rx-1 (Fwd Run/Rev Run)	0–4	–
	Frq	Frequency reference source	2	V1	0–8	–
bA	bA.4	2nd Command source	0	Keypad	0–4	–
	bA.5	2nd Frequency reference source	0	Keypad-1	0–8	–
In	In.65–In.69	Px terminal configuration	15	2nd Source	0–52	–

2nd Operation Mode Setting Details

Pr. Code	Description
bA.4 Cmd 2nd Src bA.5 Freq 2nd Src	If signals are provided to the multi-function terminal set as the 2nd command source (2nd Source), the operation can be performed using the set values from bA.4, bA.5 instead of the set values from the drv and Frq codes in the Operation group. The 2nd command source settings cannot be changed while operating with the 1st command source (Main Source).

CAUTION:



- *WHEN SETTING THE MULTI-FUNCTION TERMINAL TO THE 2ND COMMAND SOURCE (2ND SOURCE) AND INPUT (ON) THE SIGNAL, OPERATION STATE IS CHANGED BECAUSE THE FREQUENCY SETTING AND THE OPERATION COMMAND WILL BE CHANGED TO THE 2ND COMMAND. BEFORE SHIFTING INPUT TO THE MULTI-FUNCTION TERMINAL, ENSURE THAT THE 2ND COMMAND IS CORRECTLY SET. NOTE THAT IF THE DECELERATION TIME IS TOO SHORT OR INERTIA OF THE LOAD IS TOO HIGH, AN OVERVOLTAGE FAULT TRIP MAY OCCUR.*
- *DEPENDING ON THE PARAMETER SETTINGS, THE DRIVE MAY STOP OPERATING WHEN YOU SWITCH THE COMMAND MODES.*



















MULTI-FUNCTION INPUT TERMINAL CONTROL

Filter time constants and the type of multi-function input terminals can be configured to improve the response of input terminals

Pr. Group	Pr. Code	Name	Parameter Setting	Setting Range	Unit
In	In.85	Multi-function input terminal On filter	10	0-10000	ms
	In.86	Multi-function input terminal Off filter	3	0-10000	ms
	In.87	Multi-function input terminal selection	0 0000*	-	-
	In.88	NO/NC selection of operation command	0	0-1	-
	In.90	Multi-function input terminal status	0 0000*	-	-

*See "Bit Selection" on page 4-3 for details

Multi-function Input Terminal Control Setting Details

Pr. Code	Description						
In.84 DI Delay Sel	<p>Select whether or not to activate the time values set at In.85 and In.86. If deactivated, the time values are set to the default values at In.85 and In.86. If activated, the set time values at In.85 and In.86 are set to the corresponding terminals. See "Bit Selection" on page 4-3 for details</p> <table border="1"> <thead> <tr> <th>Items</th> <th>Enable state of terminal</th> <th>Disable state of terminal</th> </tr> </thead> <tbody> <tr> <td>Keypad</td> <td></td> <td></td> </tr> </tbody> </table>	Items	Enable state of terminal	Disable state of terminal	Keypad		
Items	Enable state of terminal	Disable state of terminal					
Keypad							
In.85 DI On Delay, In.86 DI Off Delay	<p>If the input terminal's state is not changed during the set time, when the terminal receives an input, it is recognized as On or Off.</p>						
In.87 DI NC/NO Sel	<p>Select terminal contact types for each input terminal. The position of the indicator light corresponds to the segment that is on as shown in the table below. With the bottom segment on, it indicates that the terminal is configured as a A terminal (Normally Open) contact. With the top segment on, it indicates that the terminal is configured as a B terminal (Normally Closed) contact. Terminals are numbered P1-P5, from right to left. See "Bit Selection" on page 4-3 for details</p> <table border="1"> <thead> <tr> <th>Items</th> <th>B contact status</th> <th>A contact status</th> </tr> </thead> <tbody> <tr> <td>Keypad</td> <td></td> <td></td> </tr> </tbody> </table>	Items	B contact status	A contact status	Keypad		
Items	B contact status	A contact status					
Keypad							
In.88 FX/RX NO/NC Sel	<p>Select whether to use the terminal set to FX/RX as NO (Normal Open) only or to use as NO (Normal Open) and NC(Normal Close). If set to 1: NO only, the terminal in which the functions are set to FX/RX cannot be set as NC. If set to 0: NO/NC, terminals set as FX/RX can also be set as NC.</p>						
In.90 DI Status	<p>Display the configuration of each contact. When a segment is configured as Normally Open (A) terminal using In.87, the On condition is indicated by the top segment turning on. The Off condition is indicated when the bottom segment is turned on. When contacts are configured as Normally Closed (B) terminals, the segment lights behave conversely. Terminals are numbered P1-P5, from right to left. See "Bit Selection" on page 4-3 for details. If using Extension IO card, use the Left arrow key on the keypad to display the status of P8, P9 and P10.</p> <table border="1"> <thead> <tr> <th>Items</th> <th>Bit ON when A contact is set</th> <th>Bit OFF when A contact is set</th> </tr> </thead> <tbody> <tr> <td>Keypad</td> <td></td> <td></td> </tr> </tbody> </table>	Items	Bit ON when A contact is set	Bit OFF when A contact is set	Keypad		
Items	Bit ON when A contact is set	Bit OFF when A contact is set					
Keypad							

FIRE MODE OPERATION

This function is used to allow the drive to ignore minor faults during emergency situations, such as fire, and provides continuous operation to fire pumps.

When turned on, Fire mode forces the drive to ignore all minor fault trips and repeat a Reset and Restart for major fault trips, regardless of the restart trial count limit. The retry delay time set at Pr.10 (Retry Delay) still applies while the drive performs a Reset and Restart.

Fire Mode Parameter Settings

Pr. Group	Pr. Code	Name	Parameter Setting		Setting Range	Unit
Ad	Ad.80	Fire Mode selection	1	Fire Mode	0–2	–
	Ad.81	Fire Mode frequency	0–60		0–60	–
	Ad.82	Fire Mode run direction	0–1		0–1	–
	Ad.83	Fire Mode operation count	Not configurable		–	–
In	In.65–In.69	Px terminal configuration	51	Fire Mode	0–52	–

The drive runs in Fire mode when Ad.80 (Fire Mode Sel) is set to '2 (Fire Mode)', and the multi-function terminal (In.65–In.69) configured for Fire mode (51: Fire Mode) is turned on. The Fire mode count increases by 1 at Ad.83 (Fire Mode Count) each time a Fire mode operation is run.

The drive runs in Fire Mode when Ad.80 (Fire Mode Sel) is set to Fire Mode Test, and the multi-function terminal (In.65–In.69 Px) configured for the fire mode (51: Fire Mode) is turned on. But when the minor fault trips are ignored or there are major fault trips, automatic Reset/Restart is not attempted, and the Fire Mode Count is not increased.



CAUTION: FIRE MODE OPERATION MAY RESULT IN DRIVE MALFUNCTION. NOTE THAT FIRE MODE OPERATION VOIDS THE PRODUCT WARRANTY – THE DRIVE IS COVERED BY THE PRODUCT WARRANTY ONLY WHEN THE FIRE MODE COUNT IS '0'.

Fire Mode Function Setting Details

Pr. Code	Description	Details
Ad.81 Fire Mode frequency	Fire mode frequency reference	The frequency set at Ad.81 (Fire mode frequency) is used for the drive operation in Fire mode. The Fire mode frequency takes priority over the Jog frequency, Multi-step frequencies, and the keypad input frequency.
dr.3 Acc Time dr.4 Dec Time	Fire mode Acc/Dec times	When Fire mode operation is turned on, the drive accelerates for the time set at dr.3 (Acc Time), and then decelerates based on the deceleration time set at dr.4 (Dec Time). It stops when the Px terminal input is turned off (Fire mode operation is turned off).
Pr.10 Retry Delay	Fault trip process	<p>Some fault trips are ignored during Fire mode operation. The fault trip history is saved, but trip outputs are disabled even when they are configured at the multi-function output relays. Fault trips that are ignored in Fire mode:</p> <ul style="list-style-type: none"> BX, External Trip, Low Voltage Trip, Drive Overheat, Drive Overload, Overload, Electrical Thermal Trip, Input/Output Open Phase, Motor Overload, Fan Trip, No Motor Trips, and other minor fault trips. <p>For the following fault trips, the drive performs a Reset and Restart until the trip conditions are released. The retry delay time set at Pr.10 (Retry Delay) applies while the drive performs a Reset and Restart.</p> <ul style="list-style-type: none"> Over Voltage, Over Current1(OC1), Ground Fault Trip <p>The drive stops operating when the following fault trips occur:</p> <ul style="list-style-type: none"> H/W Diag, Over Current 2 (Arm–Short)

LEARNING ADVANCED FEATURES

This section describes the advanced features of the ACG drive. Check the reference page in the table to see the detailed description for each of the advanced features.

Advanced Tasks	Description	Ref.
Auxiliary frequency operation	Use the main and auxiliary frequencies in the predefined formulas to create various operating conditions. Auxiliary frequency operation is ideal for Draw Operation* as this feature enables fine-tuning of operation speeds.	4-84
Jog operation	Jog operation is a kind of a manual operation. The drive operates to a set of parameter settings predefined for Jog operation, while the Jog command button is pressed.	4-88
Up-down operation	Uses the upper and lower limit value switch output signals (i.e. signals from a flow meter) as Acc/Dec commands to motors.	4-89
Safety operation mode	This safety feature allows the drive's operation only after a signal is input to the multi-function terminal designated for the safety operation mode. This feature is useful when extra care is needed in operating the drive using the multi-purpose terminals.	4-92
Dwell operation	Use this feature for the lift-type loads such as elevators, when the torque needs to be maintained while the brakes are applied or released.	4-93
Slip compensation	This feature ensures that the motor rotates at a constant speed, by compensating for the motor slip as a load increases.	4-95
PID control	PID control provides constant automated control of flow, pressure, and temperature by adjusting the output frequency of the drive.	4-96
Auto-tuning	Used to automatically measure the motor control parameters to optimize the drive's control mode performance.	4-102
Sensorless vector control	An efficient mode to control magnetic flux and torque without special sensors. Efficiency is achieved through the high torque characteristics at low current when compared with the V/F control mode.	4-104
Energy buffering operation	Used to maintain the DC link voltage for as long as possible by controlling the drive output frequency during power interruptions, thus to delay a low voltage fault trip.	4-109
Energy saving operation	Used to save energy by reducing the voltage supplied to motors during low-load and no-load conditions.	4-112
Speed search operation	Used to prevent fault trips when the drive voltage is output while the motor is idling or free-running.	4-113
Auto restart operation	Auto restart configuration is used to automatically restart the drive when a trip condition is released, after the drive stops operating due to activation of protective devices (fault trips).	4-117
Second motor operation	Used to switch equipment operation by connecting two motors to one drive. Configure and operate the second motor using the terminal input defined for the second motor operation.	4-119
Commercial power source switch operation	Used to switch the power source to the motor from the drive output to a commercial power source, or vice versa.	4-120
Cooling fan control	Used to control the cooling fan of the drive.	4-121
Multi-function IO Timer settings	Set the timer value and control the On/Off state of the multi-function output and relay.	4-125
Brake control	Used to control the On/Off operation of the load's electronic braking system.	4-126
Multi-function output On/Off control	Set standard values and turn On/Off the output relays according to the analog input value.	4-127
Regeneration prevention for press operation.	Used during a press operation to avoid motor regeneration, by increasing the motor operation speed.	4-127

*Draw operation is an open loop tension control. This feature allows a constant tension to be applied to the material that is drawn by a motor-driven device, by fine-tuning the motor speed using operation frequencies that are proportional to a ratio of the main frequency reference.

OPERATING WITH AUXILIARY REFERENCES

Frequency references can be configured with various calculated conditions that use the main and auxiliary frequency references simultaneously. The main frequency reference is used as the operating frequency, while auxiliary references are used to modify and fine-tune the main reference.

Pr. Group	Pr. Code	Name	Parameter Setting		Setting Range	Unit
Operation	Frq	Frequency reference source	0	Keypad-1	0-8	-
bA	bA.1	Auxiliary frequency reference source	1	V1	0-4	-
	bA.2	Auxiliary frequency reference calculation type	0	M+(G*A)	0-7	-
	bA.3	Auxiliary frequency reference gain	0.0	-	-200.0-200.0	%
In	In.65- In.69	Px terminal configuration	40	dis Aux Ref	0-52	-

The table above lists the available calculated conditions for the main and auxiliary frequency references. Refer to the table to see how the calculations apply to an example where the Frq code has been set to 0(Keypad-1), and the drive is operating at a main reference frequency of 30.00 Hz. Signals at -10 – +10V are received at terminal V1, with the reference gain set at 5%. In this example, the resulting frequency reference is fine-tuned within the range of 27.00–33.00 Hz [Codes In.1–In.16 must be set to the default values, and In.6 (V1 Polarity), set to 1 (Bipolar)].

AUXILIARY REFERENCE SETTING DETAILS

Pr. Code	Description		
bA.1 Aux Ref Src	Set the input type to be used for the auxiliary frequency reference		
	Configuration	Description	
	0	None	Auxiliary frequency reference is disabled.
	1	V1	Sets the V1 (voltage) terminal at the control terminal block as the source of auxiliary frequency reference.
	3	V0	Select the potentiometer dial of keypad as auxiliary command.
4	I2	Sets the I2 (current) terminal at the control terminal block as the source of auxiliary frequency reference (SW2 must be set to "current").	
bA.2 Aux Calc Type	Set the auxiliary reference gain with bA.3 (Aux Ref Gain) to configure the auxiliary reference and set the percentage to be reflected when calculating the main reference. Note that items 4–7 below may result in either plus (+) or minus (-) references (forward or reverse operation) even when unipolar analog inputs are used.		
	Configuration	Formula for frequency reference	
	0	$M+(G \cdot A)$	Main reference+(bA.3xbA.1xIn.1)
	1	$M \cdot (G \cdot A)$	$x(bA.3xbA.1)$
	2	$M / (G \cdot A)$	Main reference/(bA.3xbA.1)
	3	$M + \{M \cdot (G \cdot A)\}$	Main reference+{Main reference x(bA.3xbA.1)}
	4	$M + G \cdot 2 \cdot (A - 50)$	Main reference+bA.3x2x(bA.1-50)x In.1
	5	$M \cdot \{G \cdot 2 \cdot (A - 50)\}$	Main reference x{bA.3x2x(bA.1-50)}
	6	$M / \{G \cdot 2 \cdot (A - 50)\}$	Main reference/{bA.3x2x(bA.1-50)}
7	$M + M \cdot G \cdot 2 \cdot (A - 50)$	Main reference+Main reference x bA.3x2x(bA.1-50)	
M: Main frequency reference (Hz or rpm) G: Auxiliary reference gain (%) A: Auxiliary frequency reference (Hz or rpm) or gain (%)			
bA.3 Aux Ref Gain	Adjust the size of the input (bA.1 Aux Ref Src) configured for auxiliary frequency.		
In.65–In.69 Px Define	Set one of the multi-function input terminals to 40(dis Aux Ref) and turn it on to disable the auxiliary frequency reference. The drive will operate using the main frequency reference only.		

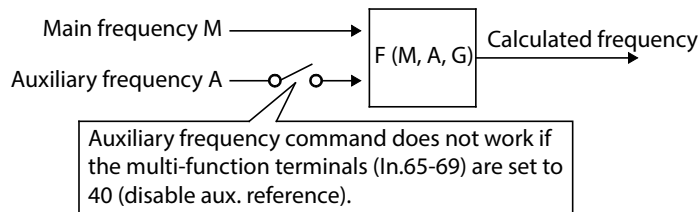

AUXILIARY REFERENCE OPERATION Ex #1**Keypad Frequency Setting is Main Frequency and V1 Analog Voltage is Auxiliary Frequency**

- Main frequency: Keypad (operation frequency 30Hz)
- Maximum frequency setting (dr.20): 400Hz
- Auxiliary frequency setting (ba.1): V1[Display by percentage(%) or auxiliary frequency (Hz) depending on the operation setting condition]
- Auxiliary reference gain setting (ba.3): 50%
- In.1–In.32: Factory default

Example: an input voltage of 6V is supplied to V1, and the frequency corresponding to 10V is 60Hz. The table below shows the auxiliary frequency A as 36Hz[=60Hz X (6V/10V)] or 60%[= 100% X (6V/10V)].

Setting*	Calculating final command frequency**
0	$M[\text{Hz}] + (G\% \cdot A[\text{Hz}])$ 30Hz(M) + (50%(G)x36Hz(A))=48Hz
1	$M[\text{Hz}] \cdot (G\% \cdot A\%)$ 30Hz(M)x(50%(G)x60%(A))=9Hz
2	$M[\text{Hz}] / (G\% \cdot A\%)$ 30Hz(M)/(50%(G)x60%(A))=100Hz
3	$M[\text{Hz}] + \{M[\text{Hz}] \cdot (G\% \cdot A\%)\}$ 30Hz(M) + {30[Hz]x(50%(G)x60%(A))}=39Hz
4	$M[\text{Hz}] + G\% \cdot 2 \cdot (A\% - 50\%) [\text{Hz}]$ 30Hz(M) + 50%(G)x2x(60%(A)-50%)x60Hz= 36Hz
5	$M[\text{Hz}] \cdot \{G\% \cdot 2 \cdot (A\% - 50\%)\}$ 30Hz(M)x{50%(G)x2x(60%(A)-50%)}= 3Hz
6	$M[\text{Hz}] / \{G\% \cdot 2 \cdot (A\% - 50\%)\}$ 30Hz(M)/{50%(G)x2x(60%-50%)}=300Hz
7	$M[\text{Hz}] + M[\text{Hz}] \cdot G\% \cdot 2 \cdot (A\% - 50\%)$ 30Hz(M) + 30Hz(M)x50%(G)x2x(60%(A)-50%)=33Hz

*M: main frequency reference (Hz or rpm)/G: auxiliary reference gain (%)/A: auxiliary frequency reference (Hz or rpm) or gain (%).

**If the frequency setting is changed to rpm, it is converted to rpm instead of Hz.

AUXILIARY REFERENCE OPERATION Ex #2**Keypad Frequency Setting is Main Frequency and I2 Analog Voltage is Auxiliary Frequency**

- Main frequency: Keypad (Operation frequency 30Hz)
- Maximum frequency setting (dr.20): 400Hz
- Auxiliary frequency setting (ba.1): I2 [Display by percentage(%) or auxiliary frequency(Hz) depending on the operation setting condition]
- Auxiliary reference gain setting (ba.3): 50%
- In.1–In.32: Factory default

Example: an input current of 10.4 mA is applied to I2, with the frequency corresponding to 20mA of 60Hz. The table below shows auxiliary frequency A as 24Hz[=60[Hz] X {(10.4[mA]-4[mA])/(20[mA] - 4[mA])}] or 40%[=100% X {(10.4[mA] - 4[mA])/(20[mA] - 4[mA])}].

Setting*	Calculating final command frequency**
0	$M[\text{Hz}] + (G\% \cdot A[\text{Hz}])$ 30Hz(M) + (50%(G)x24Hz(A))=42Hz
1	$M[\text{Hz}] \cdot (G\% \cdot A\%)$ 30Hz(M)x(50%(G)x40%(A))=6Hz
2	$M[\text{Hz}] / (G\% \cdot A\%)$ 30Hz(M)/(50%(G)x40%(A))=150Hz
3	$M[\text{Hz}] + \{M[\text{Hz}] \cdot (G\% \cdot A\%)\}$ 30Hz(M) + {30[Hz]x(50%(G)x40%(A))}=36Hz
4	$M[\text{Hz}] + G\% \cdot 2 \cdot (A\% - 50\%) [\text{Hz}]$ 30Hz(M) + 50%(G)x2x(40%(A)-50%)x60Hz=24Hz
5	$M[\text{Hz}] \cdot \{G\% \cdot 2 \cdot (A\% - 50\%)\}$ 30Hz(M)x{50%(G)x2x(40%(A)-50%)} = -3Hz(Reverse)
6	$M[\text{Hz}] / \{G\% \cdot 2 \cdot (A\% - 50\%)\}$ 30Hz(M)/{50%(G)x2x(60%-40%)} = -300Hz(Reverse)
7	$M[\text{Hz}] + M[\text{Hz}] \cdot G\% \cdot 2 \cdot (A\% - 50\%)$ 30Hz(M) + 30Hz(M)x50%(G)x2x(40%(A)-50%)=27Hz

*M: main frequency reference (Hz or rpm)/G: auxiliary reference gain (%)/A: auxiliary frequency reference Hz or rpm) or gain (%).

**If the frequency setting is changed to rpm, it is converted to rpm instead of Hz.

AUXILIARY REFERENCE OPERATION Ex #3***V1 is Main Frequency and I2 is Auxiliary Frequency***

- Main frequency: V1 (frequency command setting to 5V and is set to 30Hz)
- Maximum frequency setting (dr.20): 400Hz
- Auxiliary frequency (bA.1): I2[Display by percentage (%) or auxiliary frequency (Hz) depending on the operation setting condition]
- Auxiliary reference gain (bA.3): 50%
- In.1–In.32: Factory default

Example: an input current of 10.4 mA is applied to I2, with the frequency corresponding to 20mA of 60Hz. The table below shows auxiliary frequency A as 24Hz(=60[Hz]x{(10.4[mA]-4[mA])/(20[mA]-4[mA])}) or 40%(=100% x {(10.4[mA] - 4[mA]) / (20 [mA] - 4[mA])}).

Setting*		Calculating final command frequency**
0	M[Hz] + (G%*A[Hz])	30Hz(M) + (50%(G)x24Hz(A))=42Hz
1	M[Hz]*(G%*A%)	30Hz(M)x(50%(G)x40%(A))=6Hz
2	M[Hz]/(G%*A%)	30Hz(M)/(50%(G)x40%(A))=150Hz
3	M[Hz] + {M[Hz]*(G%*A%)}	30Hz(M) + {30[Hz]x(50%(G)x40%(A))}=36Hz
4	M[Hz] + G%*2*(A%-50%)*A[Hz]	30Hz(M) + 50%(G)x2x(40%(A)-50%)x60Hz=24Hz
5	M[Hz]*{G%*2*(A%-50%)}	30Hz(M)x{50%(G)x2x(40%(A)-50%)}= -3Hz(Reverse)
6	M[Hz]/{G%*2*(A%-50%)}	30Hz(M)/{50%(G)x2x(60%-40%)}= -300Hz(Reverse)
7	M[Hz] + M[Hz]*G%*2*(A%-50%)	30Hz(M) + 30Hz(M)x50%(G)x2x(40%(A)-50%)=27Hz

*M: main frequency reference (Hz or rpm)/G: auxiliary reference gain (%)/A: auxiliary frequency reference (Hz or rpm) or gain (%).
 **If the frequency setting is changed to rpm, it is converted to rpm instead of Hz.



NOTE: When the maximum frequency value is high, output frequency deviation may result due to analog input variation and deviations in the calculations.

JOG OPERATION

The jog operation allows for a temporary control of the drive. You can enter a jog operation command using the multi-function terminals.

The jog operation is the second highest priority operation, after the dwell operation. If a jog operation is requested while operating the multi-step, up-down, or 3-wire operation modes, the jog operation overrides all other operation modes.

JOG OPERATION 1—FORWARD JOG BY MULTI-FUNCTION TERMINAL

The jog operation is available in either forward or reverse direction, using the keypad or multi-function terminal inputs. The table below lists parameter setting for a forward jog operation using the multi-function terminal inputs.

Pr. Group	Pr. Code	Name	Parameter Setting		Setting Range	Unit
dr	dr.11	Jog frequency	10.00		0.50–Maximum frequency	Hz
	dr.12	Jog operation acceleration time	20.00		0.00–600.00	sec
	dr.13	Jog operation deceleration time	30.00		0.00–600.00	sec
In	In.65–In.69	Px terminal configuration	6	JOG	0–52	–

Forward Jog Description Details

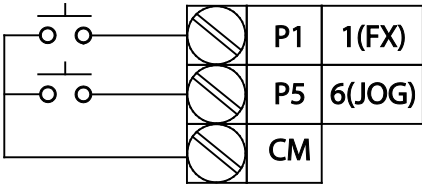
Pr. Code	Description
In.65–69 Px Define	Select the jog frequency from P1– P5 and then select 6. Jog from In.65–69.  <p style="text-align: center;">Terminal settings for jog operation</p>
dr.11 JOG Frequency	Set the operation frequency.
dr.12 JOG Acc Time	Set the acceleration speed.
dr.13 JOG Dec Time	Set the deceleration speed.

If a signal is entered at the jog terminal while an FX operation command is on, the operation frequency changes to the jog frequency and the jog operation begins.

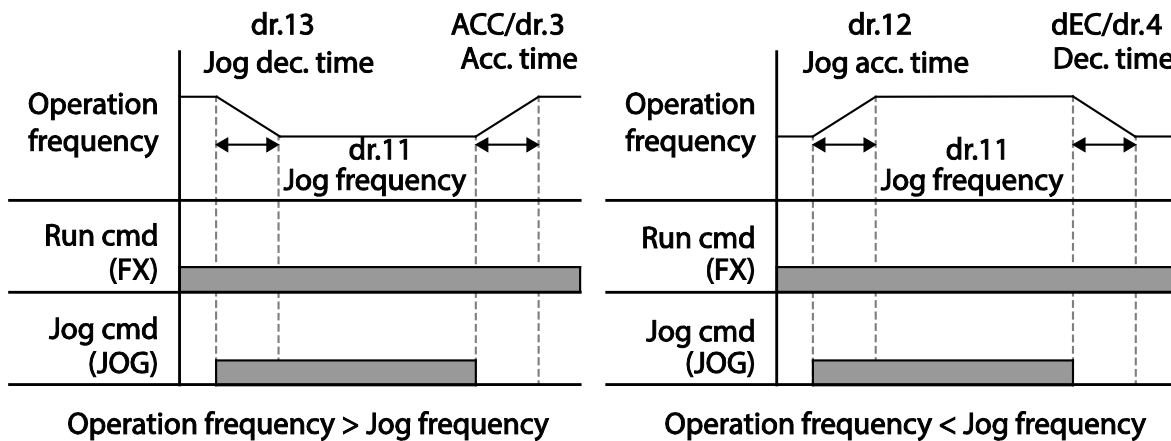

JOG OPERATION 2–FWD/REV JOG BY MULTI–FUNCTION TERMINAL

For jog operation 1, an operation command must be entered to start operation, but while using jog operation 2, a terminal that is set for a forward or reverse jog also starts an operation. The priorities for frequency, Acc/Dec time and terminal block input during operation in relation to other operating modes (Dwell, 3–wire, up/down, etc.) are identical to jog operation 1. If a different operation command is entered during a jog operation, it is ignored and the operation maintains the jog frequency.

Pr. Group	Pr. Code	Name	Parameter setting		Setting Range	Unit
dr	dr.11	Jog frequency	10.00		0.50–Maximum frequency	Hz
	dr.12	Jog operation acceleration time	20.00		0.00–600.00	sec
	dr.13	Jog operation deceleration time	30.00		0.00–600.00	sec
In	In.65–In.69	Px terminal configuration	46	FWD JOG	0–52	–
			47	REV JOG		

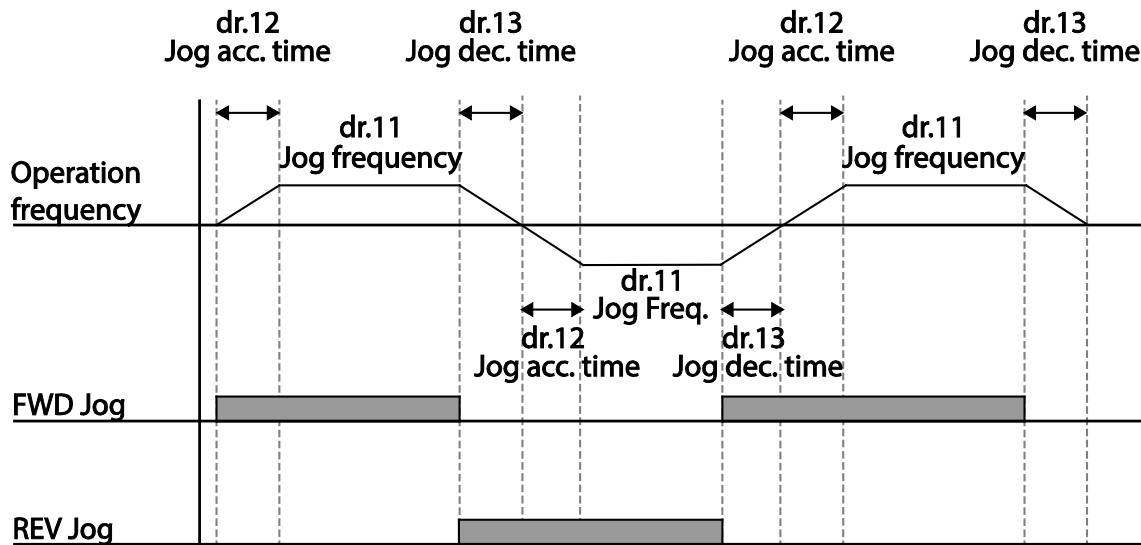

UP–DOWN OPERATION

The Acc/Dec time can be controlled through input at the multi–function terminal block. Similar to a flowmeter, the up–down operation can be applied easily to a system that uses the upper–lower limit switch signals for Acc/Dec commands.

Pr. Group	Pr. Code	Name	Parameter Setting		Setting Range	Unit
Ad	Ad.65	Up–down operation frequency save	1	Yes	0–1	–
	Ad.85	Up–down mode selection	0	U/D Normal	0–2	–
			1	U/D Step		
			2	U/D Step+ Norm		
Ad.86	Up–down step frequency	0.00		0–Maximum Frequency	Hz	

Pr. Group	Pr. Code	Name	Parameter Setting		Setting Range	Unit
In	In.65–In.69	Px terminal configuration	17	Up	0–52	–
			18	Down		
			20	U/D Clear		
			27	U/D Enable		

If there is a multi-function terminal set to U/D Enable among the multi-function terminal blocks, the command frequency source can be changed depending on the U/D Enable terminal status. For example, when the U/D Enable signal is off, even if up-down signal is entered for the up-down operation while operating according to the analog voltage input V1, the drive will operate according to the analog voltage input V1. If the up-down switchover (U/D Enable) signal is entered, the operation will follow the up-down operation terminal input and the analog voltage input V1 will not be used for the drive operation until the up-down switchover (U/D Enable) signal is disabled. If none of the multi-function terminal blocks have a multi-function terminal set to U/D Enable, the frequency will change only according to the up-down signal. In this case, the parameter will not be changed by keypad/analog input.

Up-down Operation Setting Details

Pr. Code	Description
In.65–In.69 Px Define	<p>Select three terminals for up-down operation and set them to 17 (Up), 18 (Down) and 27 (U/D Enable), respectively. If the up-down switchover (U/D Enable) command is not entered, acceleration/deceleration will follow the operation command set in drv. If the up-down switchover (U/D Enable) command is entered during acceleration/deceleration, acceleration/deceleration will stop to wait for Up and Down commands.</p> <ul style="list-style-type: none"> When the operation command and up-down activation command is entered, the operation will be accelerated if the Up terminal signal turns On, and the acceleration will stop to operate as a constant speed if the signal turns Off. When signal is off, deceleration stops and it operates in constant speed. Deceleration stops and constant speed operation begins when both Up and Down signals are entered at the same time.

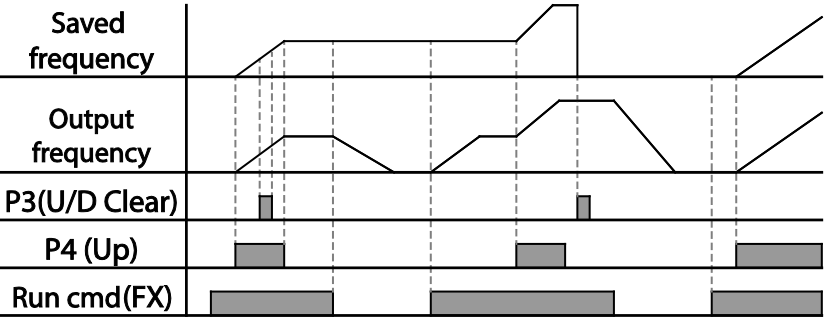
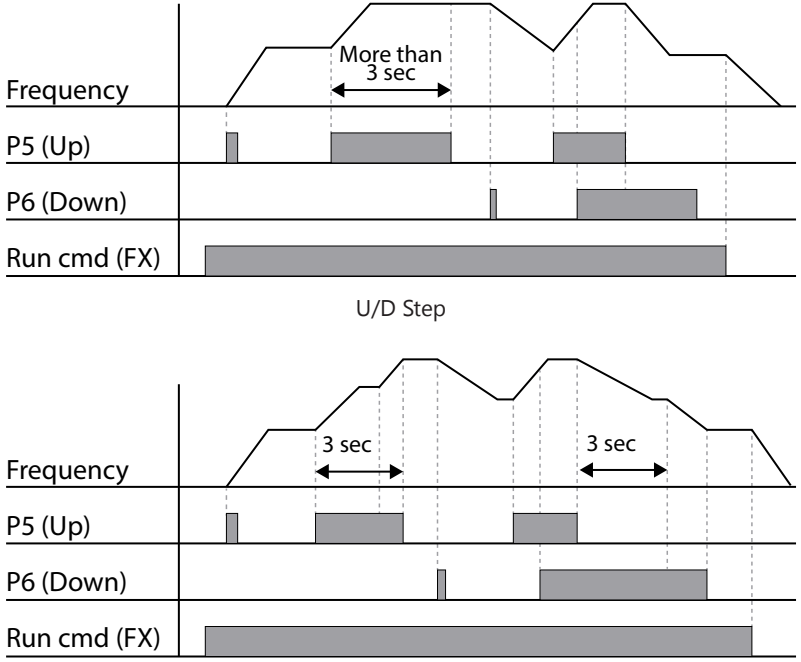
Pr. Code	Description								
<p>Ad.65 U/D Save Mode</p>	<p>During a constant speed operation, the operating frequency is saved automatically in the following conditions: the operation command (Fx or Rx) is off, a fault trip occurs, or the power is off. When the operation command is turned on again, or when the drive regains the power source or resumes to a normal operation from a fault trip, it resumes operation at the saved frequency. To delete the saved frequency, use the multi-function terminal block. Set one of the multi-function terminals to 20 (U/D Clear) and apply signals to it during constant speed operation. The saved frequency and the up-down operation configuration will be deleted.</p> 								
<p>Ad.85 U/D Mode Sel</p>	<p>Select up-down operation mode.</p> <table border="1" data-bbox="321 772 1481 1096"> <thead> <tr> <th>Setting</th> <th>Function</th> </tr> </thead> <tbody> <tr> <td>0</td> <td>U/D Normal Pressing the Up button increases the frequency to the maximum setting at a preset acceleration time. Pressing the Down button decreases the frequency to a preset deceleration speed, regardless of stop mode.</td> </tr> <tr> <td>1</td> <td>U/D Step Accelerate or decelerate according to the step frequency set in Ad.86 on the rising edge of the multi-function input set for up-down operation mode.</td> </tr> <tr> <td>2</td> <td>U/D Step+Norm Accelerate or decelerate according to the step frequency set in Ad.86 on the rising edge of the multi-function input set for up-down operation mode. If acceleration or deceleration is activated more than 3 seconds, the operation settings will change to up-down normal mode.</td> </tr> </tbody> </table> 	Setting	Function	0	U/D Normal Pressing the Up button increases the frequency to the maximum setting at a preset acceleration time. Pressing the Down button decreases the frequency to a preset deceleration speed, regardless of stop mode.	1	U/D Step Accelerate or decelerate according to the step frequency set in Ad.86 on the rising edge of the multi-function input set for up-down operation mode.	2	U/D Step+Norm Accelerate or decelerate according to the step frequency set in Ad.86 on the rising edge of the multi-function input set for up-down operation mode. If acceleration or deceleration is activated more than 3 seconds, the operation settings will change to up-down normal mode.
Setting	Function								
0	U/D Normal Pressing the Up button increases the frequency to the maximum setting at a preset acceleration time. Pressing the Down button decreases the frequency to a preset deceleration speed, regardless of stop mode.								
1	U/D Step Accelerate or decelerate according to the step frequency set in Ad.86 on the rising edge of the multi-function input set for up-down operation mode.								
2	U/D Step+Norm Accelerate or decelerate according to the step frequency set in Ad.86 on the rising edge of the multi-function input set for up-down operation mode. If acceleration or deceleration is activated more than 3 seconds, the operation settings will change to up-down normal mode.								
<p>Ad.86 U/D Step Freq</p>	<p>Set the frequency value to increase or decrease based on the up or down input.</p>								

SAFE OPERATION MODE

When the multi-function terminals are configured to operate in safe mode, operation commands can be entered in the Safe operation mode only. Safe operation mode is used to safely and carefully control the drive through the multi-function terminals.

Pr. Group	Pr. Code	Name	Parameter Setting		Setting Range	Unit
Ad	Ad.70	Safe operation selection	1	DI Dependent	–	–
	Ad.71	Safe operation stop mode	0	Free-Run	0–2	–
	Ad.72	Safe operation deceleration time	5.0		0.0–600.0	sec
In	In.65–In.69	Px terminal configuration	13	RUN Enable	0–52	–

Safe Operation Mode Setting Details

Pr. Code	Description		
In.65–In.69 Px Define	From the multi-function terminals, select a terminal to operate in safe operation mode and set it to 13 (RUN Enable).		
Ad.70 Run En Mode	Setting		Function
	0	Always Enable	Enables safe operation mode.
	1	Px Dependent	Recognizes the operation command from a multi-function input terminal.
Ad.71 Run Dis Stop	Set the operation of the drive when the multi-function input terminal in safe operation mode is off.		
	Setting		Function
	0	Free-Run	Blocks the drive output when the multi-function terminal is off.
	1	Q-Stop	The deceleration time (Q-Stop Time) used in safe operation mode. It stops after deceleration and then the operation can resume only when the operation command is entered again. The operation will not begin if only the multi-function terminal is on.
	2	Q-Stop Resume	The drive decelerates to the deceleration time (Q-Stop Time) in safe operation mode. It stops after deceleration. Then if the multi-function terminal is on, the operation resumes as soon as the operation command is entered again.
Ad.72 Q-Stop Time	Sets the deceleration time when Ad.71 (Run Dis Stop) is set to 1 (Q-Stop) or 2 (Q-Stop Resume).		

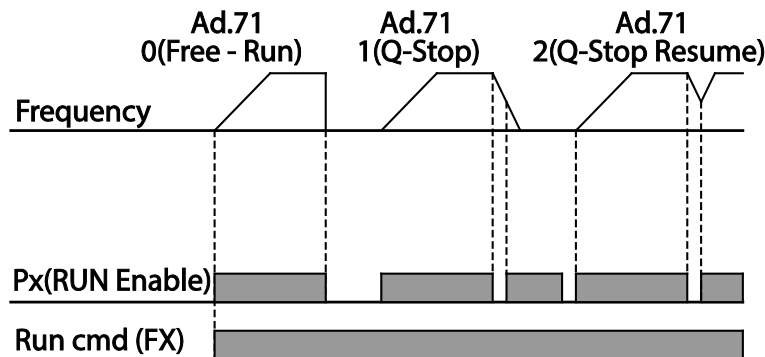

DWELL OPERATION

The dwell operation is used to maintain torque during the application and release of the brakes on lift-type loads. Drive dwell operation is based on the Acc/Dec dwell frequency and the dwell time set by the user. The following points also affect dwell operation:

- **Acceleration Dwell Operation:** When an operation command runs, acceleration continues until the acceleration dwell frequency and constant speed is reached within the acceleration dwell operation time (Acc Dwell Time). After the Acc Dwell Time has passed, acceleration is carried out based on the acceleration time and the operation speed that was originally set.
- **Deceleration Dwell Operation:** When a stop command is run, deceleration continues until the deceleration dwell frequency and constant speed is reached within the deceleration dwell operation time (Dec Dwell Freq). After the set time has passed, deceleration is carried out based on the deceleration time that was originally set, then the operation stops.

When dr.9 (Control Mode) is set to 0 (V/F), the drive can be used for operations with dwell frequency before opening the mechanical brake of lift-type loads, such as an elevator.

Pr. Group	Pr. Code	Name	Parameter Setting	Setting Range	Unit
Ad	Ad.20	Dwell frequency during acceleration	5.00	Start frequency – Maximum frequency	Hz
	Ad.21	Operation time during acceleration	0.0	0.0–10.0	s
	Ad.22	Dwell frequency during deceleration	5.00	Start frequency – Maximum frequency	Hz
	Ad.23	Operation time during deceleration	0.0	0.0–60.0	s

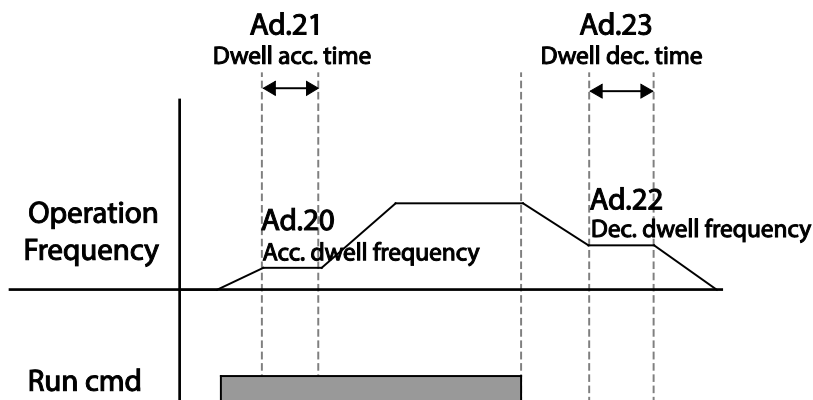

NOTE: Dwell operation does not work when:

- Dwell operation time is set to 0 sec or dwell frequency is set to 0 Hz.
- Re-acceleration is attempted from stop or during deceleration, as only the first acceleration dwell operation command is valid.

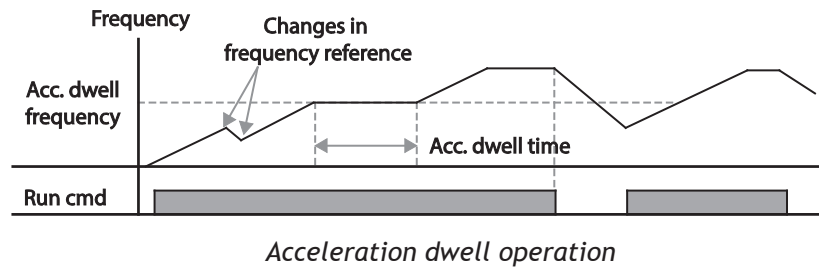

Although deceleration dwell operation is carried out whenever stop commands are entered and the deceleration dwell frequency is passed through, it does not work during a deceleration by simple frequency change (which is not a deceleration due to a stop operation), or during external brake control applications.

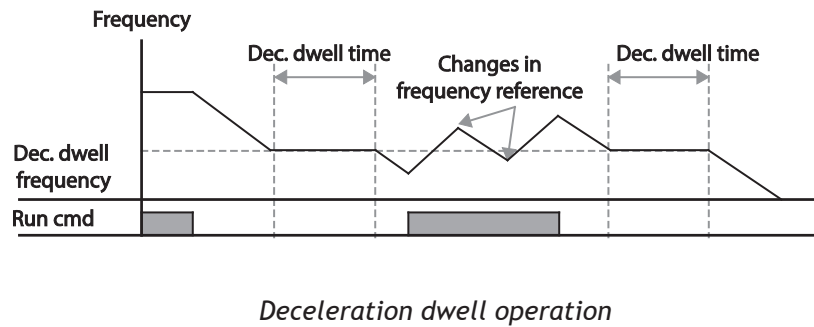

CAUTION: WHEN A DWELL OPERATION IS CARRIED OUT FOR A LIFT – TYPE LOAD BEFORE ITS MECHANICAL BRAKE IS RELEASED, MOTORS CAN BE DAMAGED OR THEIR LIFECYCLE REDUCED DUE TO OVERFLOW CURRENT IN THE MOTOR.

SLIP COMPENSATION OPERATION

Slip refers to the variation between the setting frequency (synchronous speed) and motor rotation speed. As the load increases there can be variations between the setting frequency and motor rotation speed. Slip compensation is used for loads that require compensation of these speed variations.

Pr. Group	Pr. Code	Name	Parameter Setting		Setting Range	Unit
dr	dr.9	Control mode	2	Slip Compen	–	–
	dr.14	Motor capacity	2	0.75 kW (0.75 kW based)	0–15	–
bA	bA.11	Number of motor poles	4		2–48	–
	bA.12	Rated slip speed	90 (0.75 kW based)		0–3000	rpm
	bA.13	Rated motor current	3.6 (0.75 kW based)		1.0–1000.0	A
	bA.14	Motor no-load current	1.6 (0.75 kW based)		0.5–1000.0	A
	bA.16	Motor efficiency	72 (0.75 kW based)		64–100	%
	bA.17	Load inertia rate	0 (0.75 kW based)		0–8	–

Slip Compensation Operation Setting Details

Pr. Code	Description
dr.9 Control Mode	Set dr.9 to 2 (Slip Compen) to carry out the slip compensation operation.
dr.14 Motor Capacity	Set the capacity of the motor connected to the drive.
bA.11 Pole Number	Enter the number of poles from the motor rating plate.
bA.12 Rated Slip	Enter the number of rated rotations from the motor rating plate. $f_s = f_r - \frac{Rpm \times P}{120}$ Where: <ul style="list-style-type: none"> • f_s = rated slip frequency • f_r = rated frequency • Rpm = number of rated motor rotations • P = number of motor poles
bA.13 Rated Curr	Enter the rated current from the motor rating plate.
bA.14 No-load Curr	Enter the measured current when the load on the motor axis is removed and when the motor is operated at the rated frequency. If no-load current is difficult to measure, enter a current equivalent to 30–50% of the rated motor current.

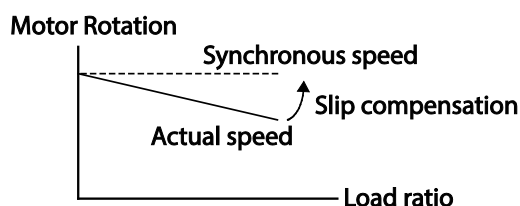

PID CONTROL

PiD control is one of the most common auto-control methods. It uses a combination of proportional, integral, and differential (PID) control that provides more effective control for automated systems. The functions of PID control that can be applied to the drive operation are as follows:

Purpose	Function
<i>Speed control</i>	Controls speed by using feedback about the existing speed level of the equipment or machinery to be controlled. Control maintains consistent speed or operates at the target speed.
<i>Pressure control</i>	Controls pressure by using feedback about the existing pressure level of the equipment or machinery to be controlled. Control maintains consistent pressure or operates at the target pressure.
<i>Flow control</i>	Controls flow by using feedback about the amount of existing flow in the equipment or machinery to be controlled. Control maintains consistent flow or operates at a target flow.
<i>Temperature control</i>	Controls temperature by using feedback about the existing temperature level of the equipment or machinery to be controlled. Control maintains a consistent temperature or operates at a target temperature.

PID BASIC OPERATION

PID operates by controlling the output frequency of the drive, through automated system process control to maintain speed, pressure, flow, temperature and tension.

Pr. Group	Pr. Code	Name	Parameter Setting		Setting Range	Unit
AP	AP.1	Application function selection	2	Proc PID	0–2	–
	AP.16	PID output monitor	–		–	–
	AP.17	PID reference monitor	–		–	–
	AP.18	PID feedback monitor	–		–	–
	AP.19	PID reference setting	50.00		–100.00–100.00	%
	AP.20	PID reference source	0	Keypad	0–7	–
	AP.21	PID feedback source	0	V1	0–6	–
	AP.22	PID controller proportional gain	50.0		0.0–1000.0	%
	AP.23	PID controller integral time	10.0		0.0–200.0	sec
	AP.24	PID controller differential time	0		0–1000	msec
	AP.25	PID controller feed–forward compensation gain	0.0		0–1000	%
	AP.26	Proportional gain scale	100.0		0.0–100.0	%
	AP.27	PID output filter	0		0–10000	ms
	AP.28	PID mode	0	Process PID	0–1	
	AP.29	PID maximum frequency	60.00		–300.00–300.00	Hz
	AP.30	PID minimum frequency	0.5		–300.00–300.00	Hz
	AP.32	PID output scale	100.0		0.1–1000.0	%
	AP.33	PID output inverse	0	No	0–1	–
	AP.34	PID controller motion frequency	0.00		0–Maximum frequency	Hz
	AP.35	PID controller motion level	0.0		0.0–100.0	%
	AP.36	PID controller motion delay time	600		0–9999	sec
	AP.37	PID sleep mode delay time	60.0		0–999.9	sec
	AP.38	PID sleep mode frequency	0.00		0–Maximum frequency	Hz
	AP.39	PID wake–up level	35		0–100	%
AP.40	PID wake–up mode selection	0	Below Level	0–2	–	
AP.43	PID unit gain	100.0		0–300	%	
AP.44	PID unit scale	2	x 1	0–4	–	
AP.45	PID 2nd proportional gain	100.00		0–1000	%	
In	In.65–In.69	Px terminal configuration	22	I–Term Clear	0–52	–
			23	PID Openloop		
			24	P Gain2		



NOTE: When the PID switch operation (switching from PID operation to general operation) enters the multi-function input, % values are converted to Hz values. The normal PID output, PID OUT, is unipolar and is limited by AP.29 (PID Limit Hi) and AP.30 (PID Limit Lo). A 100.0% calculation of the PID OUT value is based on the dr.20 (MaxFreq) parameter setting.

PID Basic Operation Setting Details

Pr. Code	Description		
AP.1 App Mode	Set the code to 2 (Proc PID) to select functions for the process PID.		
AP.16 PID Output	Displays the existing output value of the PID controller. The gain and scale that were set at AP.43–AP.44 are applied on the display.		
AP.17 PID Ref Value	Displays the existing reference value set for the PID controller. The gain and scale that were set at AP.43–AP.44 are applied on the display.		
AP.18 PID Fdb Value	Displays the input value of the PID controller that is included in the latest feedback. The gain and scale that were set at AP.43–AP.44 are applied on the display.		
AP.19 PID Ref Set	When AP.20 (PID control reference source) is set to 0 (Keypad), the reference value can be entered. If the reference source is set to any other value, the setting values for AP.19 are void.		
AP.20 PID Ref Source	Selects the reference input for the PID control. If the V1 terminal is set to PID feedback source (PID F/B Source), the V1 terminal cannot be set to the PID reference source (PID Ref Source). To set V1 as a reference source, change the feedback source.		
	Setting	Function	
	0	Keypad	Keypad
	1	V1	–10–10V input voltage terminal
	3	V0	Potentiometer dial input of keypad
	4	I2	4–20 mA input current terminal
	5	Int. 485	RS–485 input terminal
	7	Fieldbus (Ethernet)	Communication command via a communication option card
	When using the keypad, the PID reference setting can be displayed at AP.17.		
AP.21 PID F/B Source	Selects feedback input for PID control. Items can be selected as reference input, except the keypad input (Keypad–1 and Keypad–2). Feedback cannot be set to an input item that is identical to the item selected as the reference. For example, when Ap.20 (Ref Source) is set to 1 (V1), for AP. 21 (PID F/B Source), an input other than the V1 terminal must be selected.		
AP.22 PID P–Gain, AP.26 P Gain Scale	Sets the output ratio for differences (errors) between reference and feedback. If the P-gain is set to 50%, then 50% of the error is output. The setting range for P-gain is 0.0–1, 000%. For ratios below 0.1%, use AP.26 (P Gain Scale).		
AP.23 PID I– Time	Sets the time to output accumulated errors. When the error is 100%, the time taken for 100% output is set. When the integral time (PID I–Time) is set to 1 second, 100% output occurs after 1 second of the error remaining at 100%. Differences in a normal state can be reduced by PID I Time. When the multi–function terminal block is set to 21(I–Term Clear) and is turned on, all of the accumulated errors are deleted.		
AP.24 PID D–Time	Sets the output volume for the rate of change in errors. If the differential time (PID D–Time) is set to 1ms and the rate of change in errors per sec is 100%, output occurs at 1% per 10ms.		
AP.25 PID F–Gain	Sets the ratio that adds the target to the PID output. Adjusting this value leads to a faster response.		
AP.27 PID Out LPF	Used when the output of the PID controller changes too fast or the entire system is unstable, due to severe oscillation. In general, a lower value (default value=0) is used to speed up response time, but in some cases a higher value increases stability. The higher the value, the more stable the PID controller output is, but the slower the response time.		
AP.28 PID Mode	By default, parameter AP.28 is set to "Proc PID". This adds the main frequency reference based on the setting in frq/DRV07. This is more commonly suited for industrial applications that may be running a PID loop with a trim input. If you are running a fan or pump application with a PID loop it is recommended to set this to "Normal PID". Reference the function block diagram for more info.		
AP.29 PID Limit Hi, AP.30 PID Limit Lo	Limits the output of the controller.		
AP.32 PID Out Scale	Adjusts the volume of the controller output.		
AP.43 PID Unit Gain, AP.44 PID Unit Scale	Adjusts the size to fit the unit selected at AP.41 PID Unit Sel.		
AP.45 PID P2–Gain	The PID controller's gain can be adjusted using the multi–function terminal. When a terminal is selected from In.65–In.69 and set to 24 (P Gain2), and if the selected terminal is entered, the gain set in AP.22 and AP.23 can be switched to the gain set in AP.45.		

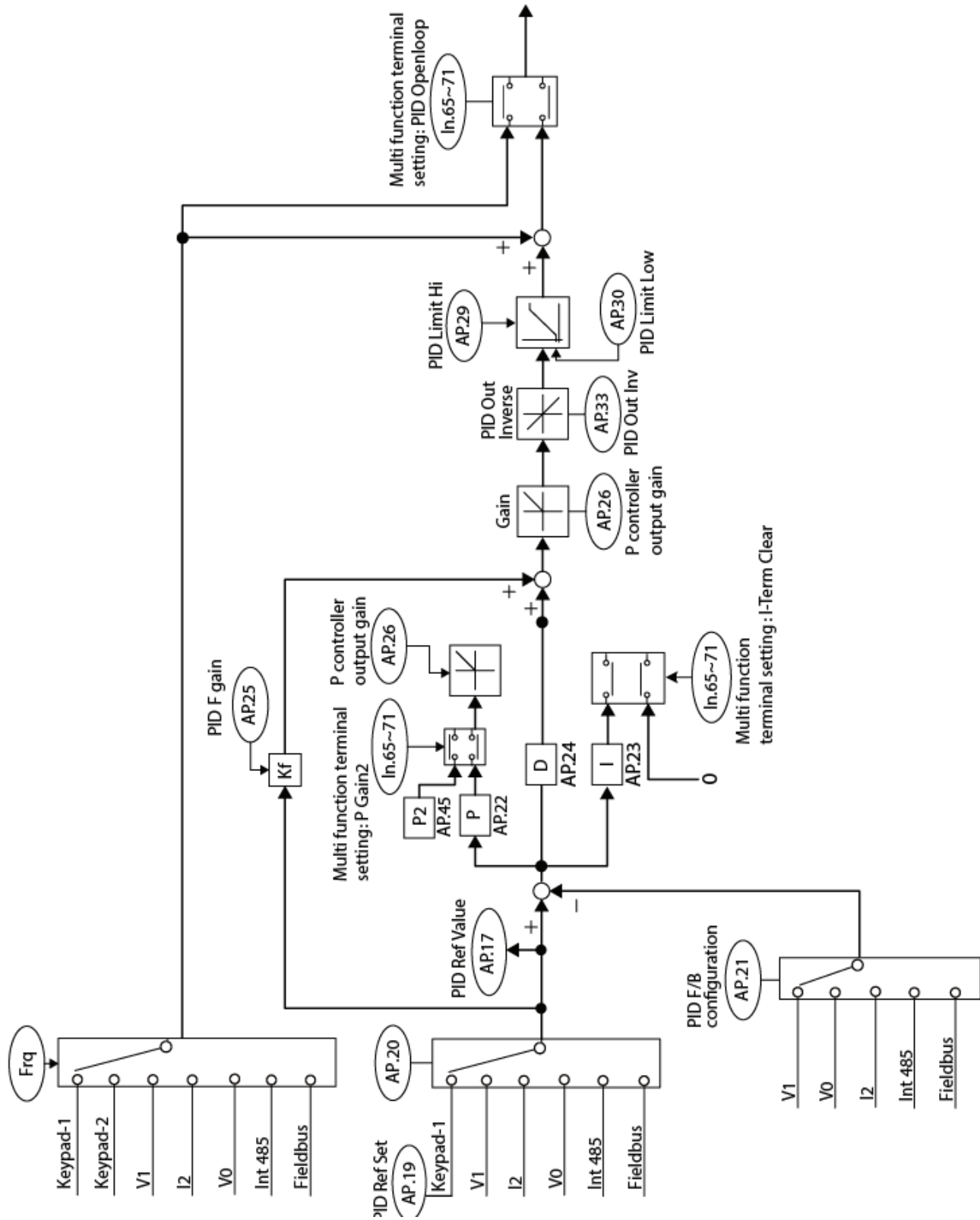

PID control block diagram

PRE-PID OPERATION

When an operation command is entered that does not include PID control, general acceleration occurs until the set frequency is reached. When the controlled variables increase to a particular point, the PID operation begins.

Pre-PID Operation Setting Details

Pr. Code	Description
AP.34 Pre-PID Freq	When general acceleration is required without the PID control, the frequency up to general acceleration is entered. If Pre-PID Freq is set to 30Hz, the general operation continues until the control variable (PID feedback variable) set at AP. 35 is exceeded.
AP.35 Pre-PID Exit, AP.36 Pre-PID Delay	When the feedback variable of the PID controller is higher than the value set at AP. 35, the PID control operation begins. However, when a value is set for AP.36 (Pre-PID Delay) and a feedback variable less than the value set at AP.36 is maintained for a set amount of time, the "pre-PID Fail" fault trip will occur and the output will be blocked.

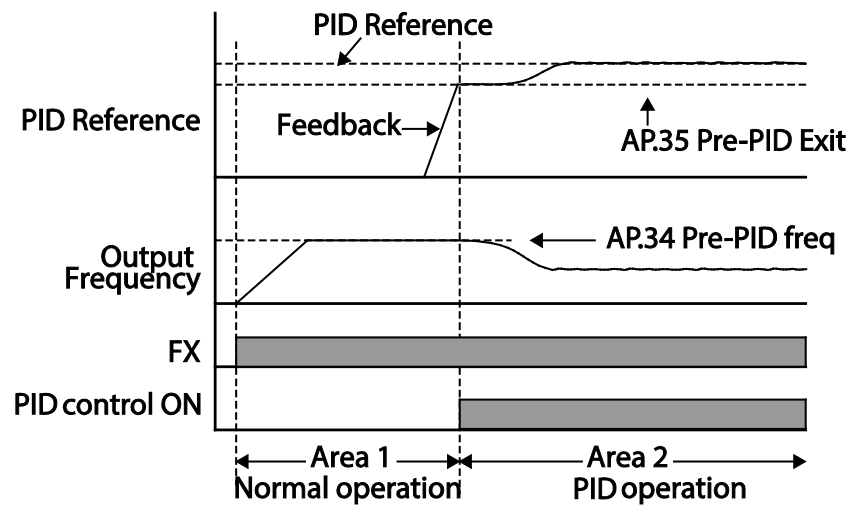

PID OPERATION SLEEP MODE

If the operation continues at a frequency lower than the set condition for PID operation, the PID operation sleep mode starts. When PID operation sleep mode starts, the operation will stop until the feedback exceeds the parameter value set at AP.39 (PID WakeUp Lev).

PID Operation Sleep Mode Setting Details

Pr. Code	Description
AP.37 PID Sleep DT, AP.38 PID Sleep Freq	If an operation frequency lower than the value set at AP.38 is maintained for the time set at AP.37, the operation stops and the PID operation sleep mode starts.
AP.39 PID WakeUp Lev, AP.40 PID WakeUp Mod	Starts the PID operation when in PID operation sleep mode. If AP. 40 is set to 0 (Below Level), the PID operation starts when the feedback variable is less than the value set as the AP. 39 parameter setting. If AP. 40 is set to 1 (Above Level), the operation starts when the feedback variable is higher than the value set at AP. 39. If AP. 40 is set to 2 (Beyond Level), the operation starts when the difference between the reference value and the feedback variable is greater than the value set at AP. 39.

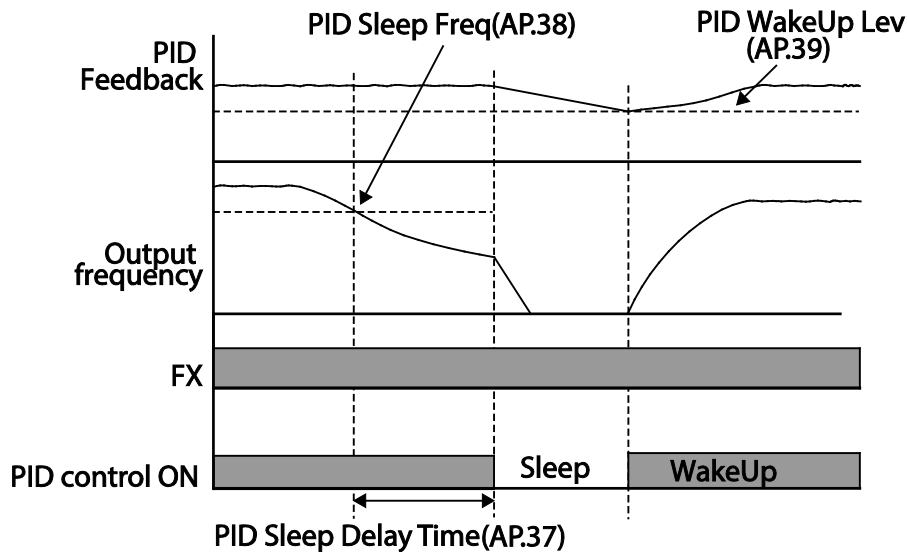

PID SWITCHING (PID OPENLOOP)

When one of the multi-function terminals (In. 65–69) is set to 23 (PID Openloop) and is turned on, the PID operation stops and is switched to general operation. When the terminal turns off, the PID operation starts again.

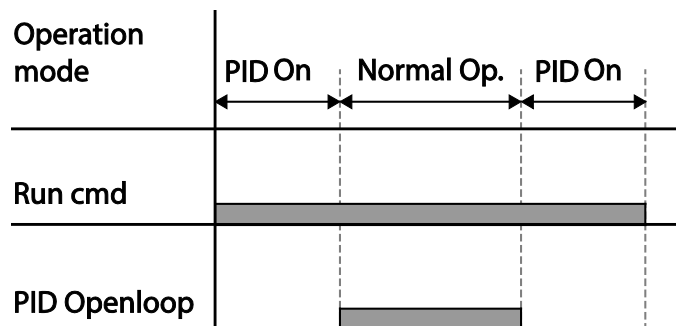

AUTO TUNING

The motor parameters can be measured automatically and can be used for auto torque boost or sensorless vector control.

Example – Auto Tuning Based on 1HP (0.75kW), 230V, 60Hz, 4-pole Motor

Pr. Group	Pr. Code	Name	Parameter Setting		Setting Range	Unit
dr	dr.14	Motor capacity	1	0.75 kW	0–15	–
bA	bA.11	Motor pole number	4		2–48	–
	bA.12	Rated slip speed	70		0–3000	rpm
	bA.13	Rated motor current	3.3		1.0–1000.0	A
	bA.14	Motor no-load current	1.7		0.5–1000.0	A
	bA.15	Motor rated voltage	220		170–480	V
	bA.16	Motor efficiency	83		64–100	%
	bA.20	Auto tuning	0	None	–	–
	bA.21	Stator resistance	2.951		Depends on the motor setting	Ω
	bA.22	Leakage inductance	25.20		Depends on the motor setting	mH
	bA.23	Stator inductance	171.1		Depends on the motor setting	mH
	bA.24	Rotor time constant	137		25–5000	ms

Auto Tuning Default Parameter Setting

	Motor Capacity kW (HP)	Rated Current (A)	No-load Current (A)	Rated Slip Frequency(Rpm)	Stator Resistance(Ω)	Leakage Inductance (mH)
230V	0.2 (0.25)	1.1	0.8	100	14.0	40.4
	0.4 (0.5)	1.9	1.0	90	6.42	38.8
	0.75 (1.0)	3.3	1.7	70	2.951	25.20
	1.5 (2.0)	5.9	2.7	70	1.156	12.07
	2.2 (3.0)	8.6	3.9	50	0.809	6.44
	3.7 (5.0)	13.8	5.7	50	0.485	4.02
	5.5 (7.5)	20.0	6.2	50	0.283	3.24
	7.5 (10)	25.5	7.4	50	0.183	2.523
	11 (15)	40.0	12.4	30	0.120	1.488
	15 (20)	53.6	15.5	30	0.084	1.118
	18.5 (25)	65.6	19.0	30	0.068	0.819
22 (30)	76.8	21.5	30	0.056	0.948	

Motor Capacity kW (HP)	Rated Current (A)	No-load Current (A)	Rated Slip Frequency(Rpm)	Stator Resistance(Ω)	Leakage Inductance (mH)	
460V	0.2 (0.25)	0.7	0.5	100	28.00	121.2
	0.4 (0.5)	1.1	0.6	90	19.40	117.0
	0.75 (1.0)	1.9	0.9	70	8.97	76.3
	1.5 (2.0)	3.4	1.7	70	3.51	37.3
	2.2 (3.0)	4.3	2.3	50	3.069	24.92
	3.7 (5.0)	6.9	3.2	50	1.820	15.36
	5.5 (7.5)	11.5	3.6	50	0.819	9.77
	7.5 (10)	15.0	4.4	50	0.526	7.58
	11 (15)	23.2	7.2	30	0.360	4.48
	15 (20)	31.0	9.0	30	0.250	3.38
	18.5 (25)	38.0	11.0	30	0.168	2.457
22 (30)	44.5	12.5	30	0.168	2.844	

Auto Tuning Parameter Setting Details

Pr. Code	Description		
bA.20 Auto Tuning	Select an auto tuning type and run it. Select one of the options and then press the [ENT] key to run the auto tuning.		
	Setting	Function	
	0	None	Auto tuning function is not enabled. Also, if you select one of the auto tuning options and run it, the parameter value will revert back to "0" when the auto tuning is complete.
	1	All (rotating type)	Measures all motor parameters, including stator resistance (Rs), stator inductance (Lsigma), no-load current (Noload Curr), rotor time constant (Tr), etc., while the motor is rotating. As the motor is rotating while the parameters are being measured, if the load is connected to the motor spindle, the parameters may not be measured accurately. For accurate measurements, remove the load attached to the motor spindle. However, note that the rotor time constant (Tr) must be measured in a stopped position.
	2	All (static type)	Measures all parameters while the motor is in the stopped position. Measures stator resistance (Rs), stator inductance (Lsigma), no-load current (Noload Curr), rotor time constant (Tr), etc., while the motor is in the stopped position. As the motor is not rotating while the parameters are measured, the measurements are not affected when the load is connected to the motor spindle. However, when measuring parameters, do not rotate the motor spindle on the load side.
	3	Rs+Lsigma (rotating type)	Measures parameters while the motor is rotating. The measured motor parameters are used for auto torque boost or sensorless vector control.
6	Tr (static type)	Measures the rotor time constant (Tr) with the motor in the stopped position and Control Mode (dr.9) is set to IM Sensorless (4).	
bA.14 Noload Curr, bA.21 Rs – bA.24 Tr	Displays motor parameters measured by auto tuning. For parameters that are not included in the auto tuning measurement list, the default setting will be displayed.		

CAUTION:

- *PERFORM AUTO TUNING ONLY AFTER THE MOTOR HAS COMPLETELY STOPPED RUNNING.*
- *BEFORE YOU RUN AUTO TUNING, CHECK THE MOTOR POLE NUMBER, RATED SLIP, RATED CURRENT, RATED VOLTAGE AND EFFICIENCY ON THE MOTOR'S RATING PLATE AND ENTER THE DATA. THE DEFAULT PARAMETER SETTING IS USED FOR VALUES THAT ARE NOT ENTERED.*
- *WHEN MEASURING ALL PARAMETERS AFTER SELECTING 2 (ALL – STATIC TYPE) AT bA.20: COMPARED WITH ROTATION TYPE AUTO TUNING WHERE PARAMETERS ARE MEASURED WHILE THE MOTOR IS ROTATING, PARAMETER VALUES MEASURED WITH STATIC AUTO TUNING MAY BE LESS ACCURATE. INACCURACY OF THE MEASURED PARAMETERS MAY DEGRADE THE PERFORMANCE OF SENSORLESS OPERATION. THEREFORE, RUN STATIC TYPE AUTO TUNING BY SELECTING 2 (ALL) ONLY WHEN THE MOTOR CANNOT BE ROTATED (WHEN GEARING AND BELTS CANNOT BE SEPARATED EASILY, OR WHEN THE MOTOR CANNOT BE SEPARATED MECHANICALLY FROM THE LOAD).*

SENSORLESS VECTOR CONTROL FOR INDUCTION MOTORS

Sensorless vector control is an operation to carry out vector control without the rotation speed feedback from the motor but with an estimation of the motor rotation speed calculated by the drive. Compared to V/F control, sensorless vector control can generate greater torque at a lower level of current.

Pr. Group	Pr. Code	Name	Parameter Setting	Setting Range	Unit
dr	dr.9	Control mode	4: IM Sensorless	–	–
	dr.14	Motor capacity	Enter motor nameplate data	0–15	–
	dr.18	Base frequency	60	30–400	Hz
bA	bA.11	Motor pole number	4	2–48	–
	bA.12	Rated slip speed	Enter motor nameplate data	0–3000	Hz
	bA.13	Rated motor current	Enter motor nameplate data	1–1000	A
	bA.14	Motor no-load current	Enter motor nameplate data	0.0–1000	A
	bA.15	Rated motor voltage	220/380/440/480	170–480	V
	bA.16	Motor efficiency	Enter motor nameplate data	64–100	%
	bA.20	Auto tuning	1: All	–	–

Pr. Group	Pr. Code	Name	Parameter Setting	Setting Range	Unit
Cn	Cn.9	Pre-Excite time	1.0	0.0–60.0	s
	Cn.10	Pre-Excite amount	100.0	100.0–300.0	%
	Cn.21	Low-speed torque compensation gain	See Sensorless Vector Control Operation Guide for Induction Motors on page 4–108	50–300	%
	Cn.22	Output torque compensation gain		50–300	%
	Cn.23	Speed deviation compensation gain		50–300	%
	Cn.24	Main compensation speed deviation		50–300	%
	Cn.29	No load speed deviation compensation gain	1.06	0.50–2.00	–
	Cn.30	Speed response adjustment gain	4.0	2.0–10.0	–
	Cn.53	Torque limit setting	0: Keypad–1	0–12	–
	Cn.54	Forward direction retrograde torque limit	180.0	0.0–200.0	%
	Cn.55	Forward direction regenerative torque limit	180.0	0.0–200.0	%
	Cn.56	Reverse direction regenerative torque limit	180.0	0.0–200.0	%
	Cn.57	Reverse direction retrograde torque limit	180.0	0.0–200.0	%



CAUTION: FOR HIGH-PERFORMANCE OPERATION, THE PARAMETERS OF THE MOTOR CONNECTED TO THE DRIVE OUTPUT MUST BE MEASURED. USE AUTO TUNING (bA.20 AUTO TUNING) TO MEASURE THE PARAMETERS BEFORE YOU RUN SENSORLESS VECTOR OPERATION. TO RUN HIGH-PERFORMANCE SENSORLESS VECTOR CONTROL, THE DRIVE AND THE MOTOR MUST HAVE THE SAME CAPACITY. IF THE MOTOR CAPACITY IS SMALLER THAN THE DRIVE CAPACITY BY MORE THAN TWO LEVELS, CONTROL MAY BE INACCURATE. IN THAT CASE, CHANGE THE CONTROL MODE TO V/F CONTROL. WHEN OPERATING WITH SENSORLESS VECTOR CONTROL, DO NOT CONNECT MULTIPLE MOTORS TO THE DRIVE OUTPUT.

SENSORLESS VECTOR CONTROL OPERATION SETTING FOR INDUCTION MOTORS

To run sensorless vector control operation, set dr.9 (Control Mode) to 4 (IM sensorless), select the capacity of the motor you will use at dr.14 (Motor Capacity), and select the appropriate codes to enter the rating plate information of the motor.

Pr. Code	Input (Motor Rating Plate Information)
dr.18 Base Freq	Base frequency
bA.11 Pole Number	Motor pole number
bA.12 Rated Slip	Rated slip
bA.13 Rated Curr	Rated current
bA.15 Rated Volt	Rated voltage
bA.16 Efficiency	Efficiency (when no information is on the rating plate, default values are used.)

After setting each code, set bA.20 (Auto tuning) to 1 (All – rotation type) or 2 (All – static type) and run auto tuning. Because rotation type auto tuning is more accurate than static type auto tuning, select 1 (All – rotation type) and run auto tuning if you can rotate the motor.



NOTE: Excitation Current

A motor can be operated only after magnetic flux is generated by current flowing through a coil. The power supply used to generate the magnetic flux is called the excitation current. The stator coil that is used with the drive does not have a permanent magnetic flux, so the magnetic flux must be generated by supplying an excitation current to the coil before operating the motor.

Sensorless Vector Control Operation Setting Details for Induction Motors

Pr. Code	Description
Cn.9 PreExTime	Sets pre-excitation time. Pre-excitation is used to start the operation after performing excitation up to the motor's rated flux.
Cn.10 Flux Force	<p>Allows for the reduction of the pre-excitation time. The motor flux increases up to the rated flux with the time constant as shown in the following figure. To reduce the time taken to reach the rated flux, a higher motor flux base value than the rated flux must be provided. When the magnetic flux reaches the rated flux, the provided motor flux base value is reduced.</p>

Pr. Code	Description																
Cn.11 Hold Time	<p>Sets the zero-speed control time (hold time) in the stopped position. The output is blocked after zero-speed operation for a set period when the motor decelerates and is stopped by a stop command.</p>																
Cn.21 Out Trq. Comp. Gain at Low Spd	Cn.21 mainly has an effect on low-speed operations. For details, refer to Sensorless Vector Control Operation Guide for Induction Motors.																
Cn.22 ScaleOut Trq. Comp. Gain	Cn.22 is related to the torque load quantity that can mostly be produced by the drive. For details, refer to Sensorless Vector Control Operation Guide for Induction Motors.																
Cn.23 Spd. Comp. Sub Gain	Cn.23 mainly has an effect on the motor speed. For details, refer to Sensorless Vector Control Operation Guide for Induction Motors.																
Cn.24 Spd. Comp. Main Gain	Cn.24 mainly has an effect on the motor speed. For details, refer to Sensorless Vector Control Operation Guide for Induction Motors.																
Cn.29 Spd. Comp. Gain at No-load	Cn.29 mostly has an effect on the error level of the estimated frequency during no load. For details, refer to Sensorless Vector Control Operation Guide for Induction Motors.																
Cn.30 Spd. Response Adjustment Gain	Cn.30 is the value that is mainly changed according to the load inertia. For details, refer to Sensorless Vector Control Operation Guide for Induction Motors.																
Cn.53 Torque Lmt Src	Select a type of torque limit setting, using the keypad, terminal block analog input (V1 and I2) or communication power. When setting torque limit, adjust the torque size by limiting the speed controller output. Set the retrograde and regenerative limits for forward and reverse operation.																
	<table border="1"> <thead> <tr> <th>Setting</th> <th>Function</th> </tr> </thead> <tbody> <tr> <td>0</td> <td>Keypad-1</td> </tr> <tr> <td>1</td> <td>Keypad-2</td> </tr> <tr> <td>2</td> <td>V1</td> </tr> <tr> <td>4</td> <td>V0</td> </tr> <tr> <td>5</td> <td>I2</td> </tr> <tr> <td>6</td> <td>Int 485</td> </tr> <tr> <td>8</td> <td>Fieldbus (Ethernet)</td> </tr> </tbody> </table>	Setting	Function	0	Keypad-1	1	Keypad-2	2	V1	4	V0	5	I2	6	Int 485	8	Fieldbus (Ethernet)
	Setting	Function															
	0	Keypad-1															
	1	Keypad-2															
	2	V1															
	4	V0															
	5	I2															
6	Int 485																
8	Fieldbus (Ethernet)																
The torque limit can be set up to 200% of the rated motor torque.																	
Cn.54 FWD +Trq Lmt	Sets the torque limit for forward retrograde (motoring) operation.																
Cn.55 FWD -Trq Lmt	Sets the torque limit for forward regenerative operation.																
Cn.56 REV +Trq Lmt	Sets the torque limit for reverse regenerative operation.																
Cn.57 REV -Trq Lmt	Sets the torque limit for reverse retrograde (motoring) operation.																
In.2 Torque at 100%	Sets the maximum torque. For example, if In.2 is set to 200% and an input voltage (V1) is used, the torque limit is 200% when 10V is entered.																



CAUTION: ADJUST THE CONTROLLER GAIN ACCORDING TO THE LOAD'S CHARACTERISTICS. HOWEVER, THE MOTOR CAN OVERHEAT OR THE SYSTEM MAY BECOME UNSTABLE DEPENDING ON THE CONTROLLER GAIN SETTINGS.

SENSORLESS VECTOR CONTROL OPERATION GUIDE FOR INDUCTION MOTORS

Problem	Relevant function code	Troubleshooting
If the number of motor rotations drops due to the lack of torque.	Cn.22 Out Trq. Comp. Gain	<p>If there is a severe drop in the motor rotation to 36 RPM or more, increase the Cn.22 Out Trq. Comp. Gain value in 10% units.</p> <p>Change the Cn.24 Spd. Comp. Main Gain value in 5% units. Refer to the load-rotation count gradient according to the Cn.24 Spd. Comp. Main Gain value below.</p> <p><u>Example:</u> The gradient slants counterclockwise as the Cn.24 Spd. Comp. Main Gain value increases.</p>
If the motor rotation count error factor is 18rpm or greater, even though there is a sufficient amount of torque.	Cn.23 Spd. Comp. Sub Gain Cn.24 Spd. Comp. Main Gain	<p>Change the Cn.23 Spd. Comp. Sub Gain value in 5% units. Refer to the load-rotation count gradient according to the Cn.23 Spd. Comp. Sub Gain value below.</p> <p><u>Example:</u> The gradient slants clockwise as Cn.23 Spd. Comp. Sub Gain value increases.</p>
If torque is lacking due to a load increase in low speed (5Hz or less).	Cn.21 Out Trq. Comp. Gain at Low Spd	If torque is lacking under low speed, increase the Cn.21 value in 5% units.
If rotating in reverse direction due to a load increase in low speed (5Hz or less).	Cn.21 Out Trq. Comp. Gain at Low Spd	If rotating in reverse direction due to a load increase in low speed, decrease the Cn.21 value 5% at a time.
If low speed (3Hz or less) out-of-phase occurs because the inertia of load is high.	Cn.30 Spd. Response Adjustment Gain	Sometimes control is not possible under a low speed due to high load inertia. In this case, increase the Cn.30 value by 1 unit at a time.
If motor count error margin occurs during no load.	Cn.29 Spd. Comp. Gain at No-load	If over 10 RPM of motor rotation count error occurs during no load operation, adjust the Cn.29 value by 0.01 unit at a time.
If speed response is required.	Cn.30 Spd. Response Adjustment Gain	Although the speed response is improved the greater the Cn.30 value, speed control may become unstable. Excessive setup may cause an drive trip.

KINETIC ENERGY BUFFERING OPERATION

When the input power supply is disconnected, the drive's DC link voltage decreases, and a low voltage trip occurs blocking the output. A kinetic energy buffering operation uses regenerative energy generated by the motor during the blackout to maintain the DC link voltage. This extends the time for a low voltage trip to occur, after an instantaneous power interruption. For the KEB feature to operate properly, bA.19 input power voltage parameter must be set to match the voltage of input power.

Pr. Group	Pr. Code	Name	Parameter Setting		Setting Range	Unit
bA	bA.19	Input power voltage settings	220/380		170-480	V
Cn	Cn.77	Kinetic energy buffering selection	0	None	0-2	-
			1	KEB-1		
			2	KEB-2		
	Cn.78	Kinetic energy buffering start level	125.0		110.0-200.0	%
	Cn.79	Kinetic energy buffering stop level	130.0		Cn.78-210.0	%
	Cn.80	Energy buffering P gain	1000		1-20000	-
	Cn.81	Energy buffering I gain	500		0-20000	-
Cn.82	Energy buffering Slip gain	30.0		0-2000.0	%	
Cn.83	Energy buffering acceleration time	10.0		0.0-600.0	s	
In	In.65-In.69	Px terminal function setting	52	KEB-1 Select	-	-

KINETIC ENERGY BUFFERING OPERATION SETTING DETAILS

Pr. Code	Description		
Cn.77 KEB Select	Select the kinetic energy buffering operation when the input power is disconnected. If 1 or 2 is selected, it controls the drive's output frequency and charges the DC link (drive's DC part) with energy generated from the motor. Also, this function can be set using a terminal input. From the Px terminal function settings, select KEB-1 Select, and then turn on the terminal block to run the KEB-1 function. (If KEB-1 Select is selected, KEB-1 or KEB-2 cannot be set in Cn.77.)		
	Setting	Function	
	0	None	General deceleration is carried out until a low voltage trip occurs.
	1	KEB-1	When the input power is blocked, it charges the DC link with regenerated energy. When the input power is restored, it restores normal operation from the energy buffering operation to the frequency reference operation. KEB Acc Time in Cn.83 is applied as the operation frequency acceleration time when restoring to the normal operation.
	2	KEB-2	When the input power is blocked, it charges the DC link with regenerated energy. When the input power is restored, it changes from the energy buffering operation to the deceleration stop operation. The Dec Time in dr.4 is applied as the operation frequency deceleration time during the deceleration stop operation.
<div style="text-align: center;">KEB-1</div> <div style="text-align: center;">KEB-2</div>			
Cn.78 KEB Start Lev, Cn.79 KEB Stop Lev	Sets the start and stop points of the kinetic energy buffering operation. The set values must be based on the low voltage trip level as 100% and the stop level (Cn.79) must be set higher than the start level (Cn.78).		
Cn.80 KEB P Gain	The controller P Gain is for maintaining the voltage of the DC power section during the kinetic energy buffering operation. Change the setting value when a low voltage trip occurs right after a power failure.		
Cn.81 KEB I Gain	The controller I Gain is for maintaining the frequency during the kinetic energy buffering operation until the drive stops.		

Pr. Code	Description
Cn.82 KEB Slip Gain	The slip gain is for preventing a low voltage trip due to load when the kinetic energy buffering operation start from blackout.
Cn.83 KEB Acc Time	Set the acceleration time of operation frequency when it restores normal operation from the kinetic energy buffering operation and under the input power is restored and when KEB-1 mode is selected.



CAUTION: *DEPENDING ON THE DURATION OF INSTANTANEOUS POWER INTERRUPTIONS AND THE AMOUNT OF LOAD INERTIA, A LOW VOLTAGE TRIP MAY OCCUR EVEN DURING A KINETIC ENERGY BUFFERING OPERATION. MOTORS MAY VIBRATE DURING KINETIC ENERGY BUFFERING OPERATION FOR SOME LOADS EXCEPT VARIABLE TORQUE LOAD (FOR EXAMPLE, FAN OR PUMP LOADS).*



NOTE:

- *The performance of KEB function may vary depending on the loads (capacity, inertia, etc...). You can set a KEB Gain value for better performance.*
 - *A low voltage trip may occur immediately after a power interruption if the load is too high or the load inertia is too low. In this case, you can improve the performance by increasing the KEB I Gain value or the KEB Slip Gain value.*
 - *If the motor vibrates or the current fluctuation increases after a power interruption, you can improve the performance by increasing the KEB P Gain value or lowering the KEB I Gain value.*
-

ENERGY SAVING OPERATION

MANUAL ENERGY SAVING OPERATION

If the drive output current is lower than the current which is set at bA.14 (Noload Curr), the output voltage must be reduced as low as the level set at Ad.51 (Energy Save). The voltage before the energy saving operation starts will become the base value of the percentage. Manual energy saving operation will not be carried out during acceleration and deceleration.

Pr. Group	Pr. Code	Name	Parameter Setting		Setting Range	Unit
Ad	Ad.50	Energy saving operation	1	Manual	–	–
	Ad.51	Energy saving amount	30		0–30	%

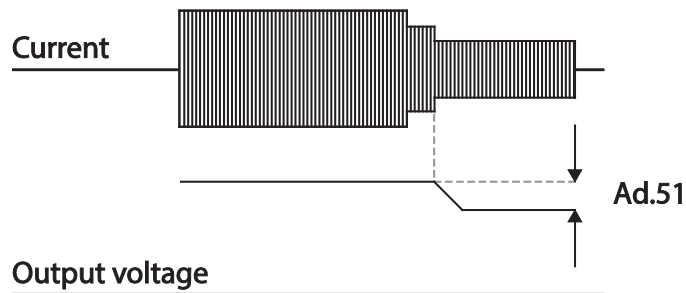

AUTOMATIC ENERGY SAVING OPERATION

The amount of energy saving can be automatically calculated based on the rated motor current (bA.13) and the no-load current (bA.14). From the calculations, the output voltage can be adjusted.

Pr. Group	Pr. Code	Name	Parameter Setting		Setting Range	Unit
Ad	Ad.50	Energy saving operation	2	Auto	–	–



CAUTION: IF OPERATION FREQUENCY IS CHANGED OR ACCELERATION AND DECELERATION IS CARRIED OUT BY A STOP COMMAND DURING THE ENERGY SAVING OPERATION, THE ACTUAL ACC/DEC TIME MAY TAKE LONGER THAN THE SET ACC/DEC TIME DUE TO THE TIME REQUIRED TO RETURN TO THE GENERAL OPERATION FROM THE ENERGY SAVING OPERATION.

SPEED SEARCH OPERATION

This operation is used to prevent fault trips that can occur while the drive output voltage is disconnected and the motor is idling. Because this feature estimates the motor rotation speed based on the drive output current, it does not give the exact speed.

Pr. Group	Pr. Code	Name	Parameter Setting		Setting Range	Unit
Cn	Cn.70	Speed search mode	0	Flying Start-1	0-1	-
			1	Flying Start-2		
	Cn.71	Speed search operation selection	0000*		0000-1111	bit
	Cn.72	Speed search reference current	150		80-200	%
	Cn.73	Speed search proportional gain	100		0-9999	-
	Cn.74	Speed search integral gain	200		0-9999	-
	Cn.75	Output block time before speed search	1.0		0-60	sec
OU	OU.31	Multi-function Relay1 define	19	Speed Search	-	-
	OU.33	Multi-function Relay2 define				

*See "Bit Selection" on page 4-3 for details

SPEED SEARCH OPERATION SETTING DETAILS

Pr. Code	Description	
Cn.70 SS Mode	Select a speed search type.	
	Setting	Function
	0	Flying Start-1
1	Flying Start-2	The speed search is carried out as the PI controls the ripple current which is generated by the counter electromotive force during no-load rotation. Because this mode establishes the direction of the idling motor (forward/reverse), the speed search function is stable regardless of the direction of the idling motor and direction of operation command. However because the ripple current is used which is generated by the counter electromotive force at idle (the counter electromotive force is proportional to the idle speed), the idle frequency is not determined accurately and re-acceleration may start from zero speed when the speed search is performed for the idling motor at low speed (about 10 – 15 Hz, though it depends on motor characteristics).

Pr. Code	Description																													
<p>Cn.71 Speed Search</p>	<p>Speed search can be selected from the following 4 options. If the top display segment is on it is enabled (On), and if the bottom segment is on it is disabled (Off). *See "Bit Selection" on page 4–3 for details</p>																													
	<p>Type and Functions of Speed Search Setting</p>																													
	<table border="1" style="width: 100%; border-collapse: collapse;"> <thead> <tr> <th colspan="4">Setting</th> <th rowspan="2">Function</th> </tr> <tr> <th>bit4</th> <th>bit3</th> <th>bit2</th> <th>bit1</th> </tr> </thead> <tbody> <tr> <td></td> <td></td> <td></td> <td>X</td> <td>Speed search for general acceleration</td> </tr> <tr> <td></td> <td></td> <td>X</td> <td></td> <td>Initialization after a fault trip</td> </tr> <tr> <td></td> <td>X</td> <td></td> <td></td> <td>Restart after instantaneous power interruption</td> </tr> <tr> <td>X</td> <td></td> <td></td> <td></td> <td>Starting with power-on</td> </tr> </tbody> </table>	Setting				Function	bit4	bit3	bit2	bit1				X	Speed search for general acceleration			X		Initialization after a fault trip		X			Restart after instantaneous power interruption	X				Starting with power-on
	Setting				Function																									
	bit4	bit3	bit2	bit1																										
				X	Speed search for general acceleration																									
			X		Initialization after a fault trip																									
		X			Restart after instantaneous power interruption																									
	X				Starting with power-on																									
	<ul style="list-style-type: none"> • Speed search for general acceleration: If bit 1 is set to 1 and the drive operation command runs, acceleration starts with speed search operation. When the motor is rotating under load, a fault trip may occur if the operation command is run for the drive to provide output voltage. The speed search function prevents such fault trip from occurring. • Initialization after a fault trip: If Bit 2 is set to 1 and Pr.8 (RST Restart) is set to 1 (Yes), the speed search operation automatically accelerates the motor to the operation frequency used before the fault trip, when the [Reset] key is pressed (or the terminal block is initialized) after a fault trip. • Automatic restart after reset of a fault trip: If bit 3 is set to 1, and if a low voltage trip occurs due to a power interruption but the power is restored before the internal power shuts down, the speed search operation accelerates the motor back to its frequency reference before the low voltage trip. 																													
<p>If an instantaneous power interruption occurs and the input power is disconnected, the drive generates a low voltage trip and blocks the output. When the input power returns, the operation frequency before the low voltage trip and the voltage is increased by the drive's inner PI control.</p> <p>If the current increases above the value set at Cn.72, the voltage stops increasing and the frequency decreases (t1 zone). If the current decreases below the value set at Cn.72, the voltage increases again and the frequency stops decelerating (t2 zone). When the normal frequency and voltage are resumed, the speed search operation accelerates the motor back to its frequency reference before the fault trip.</p>																														
<ul style="list-style-type: none"> • Starting with power-on: Set bit 4 to 1 and Ad.10 (Power-on Run) to 1 (Yes). If drive input power is supplied while the drive operation command is on, the speed search operation will accelerate the motor up to the frequency reference. 																														
<p>Cn.72 SS Sup-Current</p>	<p>The amount of current flow is controlled during speed search operation based on the motor's rated current. If Cn.70 (SS mode) is set to 1 (Flying Start-2), this code is not visible.</p>																													
<p>Cn.73 SS P/I-Gain, Cn.75 SS Block Time</p>	<p>The P/I gain of the speed search controller can be adjusted. If Cn.70 (SS Mode) is set to 1 (Flying Start-2), different factory defaults based on motor capacity are used and defined in dr.14 (Motor Capacity).</p>																													

NOTE:

- *If operated within the rated output, the ACG series drive is designed to withstand instantaneous power interruptions within 15 ms and maintain normal operation. Based on the rated heavy load current, safe operation during an instantaneous power interruption is guaranteed for 230V and 460V drives (whose rated input voltages of 200-230 VAC for 230V drives and 380-460 VAC for 460V drives.*
 - *The DC voltage inside the drive may vary depending on the output load. If the power interruption time is longer than 15 ms, a low voltage trip may occur.*
-



CAUTION: *WHEN OPERATING IN SENSORLESS MODE WHILE THE STARTING LOAD IS IN FREE-RUN, THE SPEED SEARCH FUNCTION (FOR GENERAL ACCELERATION) MUST BE SET FOR SMOOTH OPERATION. IF THE SPEED SEARCH FUNCTION IS NOT SET, AN OVERCURRENT TRIP OR OVERLOAD TRIP MAY OCCUR.*

AUTO RESTART SETTINGS

When drive operation stops due to a fault and a fault trip is activated, the drive automatically restarts based on the parameter settings.

Pr. Group	Pr. Code	Name	Parameter Setting		Setting Range	Unit
Pr	Pr.8	Select start at trip reset	0	No	0–1	–
	Pr.9	Auto restart count	0		0–10	–
	Pr.10	Auto restart delay time	1.0		0.0–60.0	s
Cn	Cn.71	Select speed search operation	–		0000*–1111	bit
	Cn.72	Speed search startup current	150		80–200	%
	Cn.73	Speed search proportional gain	100		0–9999	–
	Cn.74	Speed search integral gain	200		0–9999	–
	Cn.75	Output block time before speed search.	1.0		0.0–60.0	s

**See "Bit Selection" on page 4–3 for details*

AUTO RESTART SETTING DETAILS

Pr. Code	Description
Pr.8 RST Restart Pr.9 Retry Number Pr.10 Retry Delay	<p>Only operates when Pr.8 (RST Restart) is set to 1(Yes). The number of attempts to try the auto restart is set at Pr.9 (Auto Restart Count).</p> <p>If a fault trip occurs during operation, the drive automatically restarts after the set time programmed at Pr.10 (Retry Delay). At each restart, the drive counts the number of tries and subtracts it from the number set at Pr.9 until the retry number count reaches 0.</p> <p>After an auto restart, if a fault trip does not occur within 60 sec, it will increase the restart count number. The maximum count number is limited by the number set at Pr.9 (Auto Restart Count).</p> <p>If the drive stops due to low voltage, emergency stop (Bx), drive overheating, or hardware diagnosis, an auto restart is not activated. At auto restart, the acceleration options are identical to those of speed search operation. Codes Cn.72–Cn.75 can be set based on the load. Information about the speed search function can be found at "Speed Search Operation" on page 4–113.</p>

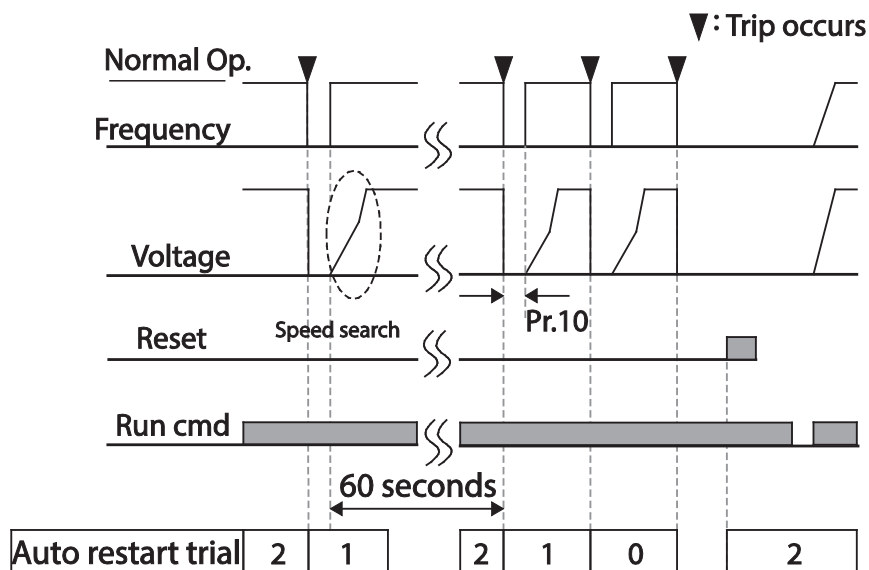

Example of auto restart with a setting of 2



CAUTION: IF THE AUTO RESTART NUMBER IS SET, BE CAREFUL WHEN THE DRIVE RESETS FROM A FAULT TRIP. THE MOTOR MAY AUTOMATICALLY ROTATE ON POWER UP.

OPERATIONAL NOISE SETTINGS (CARRIER FREQUENCY SETTINGS)

Pr. Group	Pr. Code	Name	Parameter Setting	Setting Range		Unit
Cn	Cn.4	Carrier Frequency	3.0	0.5–5 hp	2.0–15.0	kHz
				7.5–30 hp	1.0–15.0	

OPERATIONAL NOISE SETTING DETAILS

Pr. Code	Description
Cn.4 Carrier Freq	Adjust motor operational noise by changing carrier frequency settings. Power transistors (IGBT) in the drive generate and supply high frequency switching voltage to the motor. The switching speed in this process refers to the carrier frequency. If the carrier frequency is set high, it reduces operational noise from the motor, and if the carrier frequency is set low, it increases operational noise from the motor.

Refer to the table below for the change of carrier frequency settings according to the load level, control mode, and capacity.

Capacity	Heavy Load (HD)					Normal Load (ND)				
	Setting Range				Initial Value	Setting Range				Initial Value
	V/F, Slip		IM Sensorless			V/F, Slip		IM Sensorless		
	Min	Max	Min	Max		Min	Max	Min	Max	
0.5–5 hp	2	15	2	15	3	2	5	2	5	2
7.5–30 hp	1	15	2	15		1	5	2	5	

NOTE:

Factory default carrier frequency:

- Normal Load (ND): 2kHz (max 5kHz)
- Heavy Load (HD): 3kHz (max 15kHz)

ACG SERIES DRIVE DERATING STANDARD

The ACG drive is designed to respond to two types of load rates. Heavy load (heavy duty, also referred to as constant torque) and normal load (normal duty, also referred to as variable torque). The overload rate represents an acceptable load amount that exceeds rated load, and is expressed in a ratio based on the rated load and the duration. The overload capacity on the ACG series drive is 150%/1min for heavy loads, and 120%/1min for normal loads. The current rating differs from the load rating, as it also has an ambient temperature limit. For derating specifications, refer to Continuous Rated Current Derating.

Current rating for ambient temperature at normal load operation:

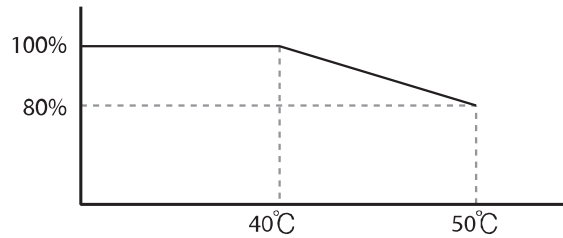

Below shows the carrier frequency rated current guaranteed area according to the load.

Drive Capacity	Normal Load	Heavy Load
230V: 1/2 hp – 3hp 460V: 1/2 hp – 5hp	2kHz	6kHz
230V: 5hp – 20hp 460V: 7.5 hp – 30hp	2kHz	4kHz

2ND MOTOR OPERATION

The 2nd motor operation is used when a single drive switch operates two motors. Using the 2nd motor operation, a parameter for the 2nd motor is set. The 2nd motor is operated when a multi-function terminal input defined as a 2nd motor function is turned on.

Pr. Group	Pr. Code	Name	Parameter Setting	Setting Range	Unit	
In	In.65– In.69	Px terminal configuration	26	2nd Motor	0–52	–

2ND MOTOR OPERATION SETTING DETAILS

Pr. Code	Description
In.65–In.69 Px Define	Set one of the the multi-function input terminals (P1–P5) to 26 (2nd Motor) to display M2 (2nd motor group) group. An input signal to a multi-function terminal set to 2nd motor will operate the motor according to the code settings listed below. However, if the drive is in operation, input signals to the multi-function terminals will not read as a 2nd motor parameter. Pr.50 (Stall Prevent) must be set first, before M2.28 (M2–Stall Lev) settings can be used. Also, Pr.40 (Electronic Thermal [ETH] Trip Sel) must be set first, before M2.29 (M2 Electronic Thermal 1 minute rating) and M2.30 (M2 Electronic Thermal continuous rating) settings.

PARAMETER SETTING AT MULTI-FUNCTION TERMINAL INPUT ON A 2ND MOTOR

Pr. Code	Description	Pr. Code	Description
M2.4 Acc Time	Acceleration time	M2.16 Inertia Rt	Load inertia rate
M2.5 Dec Time	Deceleration time	M2.17 Rs	Stator resistance
M2.6 Capacity	Motor capacity	M2.18 Lsigma	Leakage inductance
M2.7 Base Freq	Motor base frequency	M2.19 Ls	Stator inductance
M2.8 Ctrl Mode	Control mode*	M2.20 Tr	Rotor time constant
M2.10 Pole Num	Pole number	M2.25 V/F Patt	V/F pattern
M2.11 Rate Slip	Rated slip	M2.26 Fwd Boost	Forward torque boost
M2.12 Rated Curr	Rated current	M2.27 Rev Boost	Reverse torque boost
M2.13 Noload Curr	No-load current	M2.28 Stall Lev	Stall prevention level
M2.14 Rated Volt	Motor rated voltage	M2.29 ETH 1min	Motor Elec. Thermal protection 1min rating
M2.15 Efficiency	Motor efficiency	M2.30 ETH Cont	Motor Elec. Thermal protection continuous rating

Example – 2nd Motor Operation

Use the 2nd motor operation when switching operation between a 7.5 kW motor and a secondary 3.7 kW motor connected to terminal P3. Refer to the following settings.

Pr. Group	Pr. Code	Name	Parameter Setting		Setting Range	Unit
In	In.67	Terminal P3 configuration	26	2nd Motor	–	–
M2	M2.6	Motor capacity	–	3.7kW	–	–
	M2.8	Control mode	0	V/F	–	–

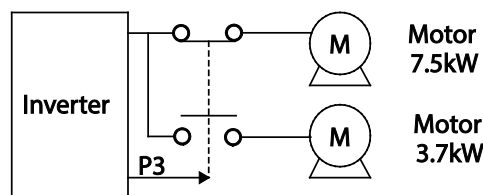

SUPPLY POWER TRANSITION

Supply power transition is used to switch the power source for the motor connected to the drive from the drive output power to the main supply power source (commercial power source), or vice versa.

Pr. Group	Pr. Code	Name	Parameter Setting		Setting Range	Unit
In	In.65–In.69	Px terminal configuration	16	Exchange	0–52	–
OU	OU.31	Multi-function Relay1 define	17	Drive Line	–	–
	OU.33	Multi-function Relay2 define	18	Comm Line	–	–

SUPPLY POWER TRANSITION SETTING DETAILS

Pr. Code	Description
In.65–In.69 Px Define	When the motor power source changes from drive output to main supply power, select a terminal to use and set the code value to 16 (Exchange). Power will be switched when the selected terminal is on. To reverse the transition, switch off the terminal.
OU.31 Relay1 Define (A1, B1, C1 terminals) OU.33 Relay2 Define (A2, C2 terminals)	Set multi-function relay to 17 (Drive Line) or 18 (COMM line). Relay operation sequence is as follows.

COOLING FAN CONTROL

This function turns the drive’s heat-sink cooling fan on and off. It is used in situations where the load stops and starts frequently, or noise free environment is required. The correct use of cooling fan control can extend the cooling fan’s life.

Pr. Group	Pr. Code	Name	Parameter Setting	Setting Range	Unit
Ad	Ad.64	Cooling fan control	0 During Run	0–2	–

COOLING FAN CONTROL DETAIL SETTINGS

Pr. Code	Description	
Ad.64 Fan Control	Settings	Description
	0 During Run	Cooling fan runs when the power is supplied to the drive and the operation command is on. The cooling fan stops when the power is supplied to the drive and the operation command is off. When the drive heat sink temperature is higher than its set value, the cooling fan operates automatically regardless of its operation status.
	1 Always On	Cooling fan runs constantly if the power is supplied to the drive.
	2 Temp Control	With power connected and the run operation command on, if the setting is in Temp Control, the cooling fan will not operate unless the temperature in the heat sink reaches the set temperature.



NOTE: Despite setting Ad.64 to 0(During Run), if the heat sink temperature reaches a set level by current input harmonic wave or noise, the cooling fan may run as a protection function.

INPUT POWER FREQUENCY AND VOLTAGE SETTINGS

Select the frequency for drive input power. If the frequency changes from 60Hz to 50Hz, all other frequency (or RPM) settings including the maximum frequency, base frequency etc., will change to 50Hz. Likewise, changing the input power frequency setting from 50Hz to 60Hz will change all related function item settings from 50Hz to 60Hz.

Pr. Group	Pr. Code	Name	Parameter Setting		Setting Range	Unit
bA	bA.10	Input power frequency	0	60Hz	0-1	-
			1	50Hz		

Set Drive input power voltage at bA.19. Low voltage fault trip level changes automatically to the set voltage standard.

Pr. Group	Pr. Code	Name	Parameter Setting		Setting Range	Unit
bA	bA.19	Input power voltage	230V	220	170-240	V
			460V	380	320-480	

PARAMETER SAVE

The parameters the user has changed through the compatible common area are not saved in the drive memory. They are used for saving the changed parameter into the drive memory after changing the compatible common area parameter. The parameters cannot be saved if the drive is operating.

Pr. Group	Pr. Code	Name	Parameter Setting		Setting Range	Unit
dr	dr.92	Parameter save	0	No	0-1	-
			1	Parameter save		

PARAMETER INITIALIZATION (RESET TO DEFAULTS)

User changes to parameters can be initialized (reset) to factory default settings on all or selected groups. However, during a fault trip situation or operation, parameters cannot be initialized.

Pr. Group	Pr. Code	Name	Parameter Setting		Setting Range	Unit
dr	dr.93	Parameter initialization	0	No	0-14	-

PARAMETER INITIALIZATION SETTING DETAILS

Pr. Code	Description		
dr.93	Setting	Function	
	0	No	-
	1	Initialize all groups	Initialize all data. Select 1(All Grp) and press [PROG/ENT] key to start initialization. On completion, 0(No) will be displayed.
	2	Initialize dr group	Initialize data by groups. Select initialize group and press [PROG/ENT] key to start initialization. On completion, 0(No) will be displayed.
	3	Initialize bA group	
	4	Initialize Ad group	
	5	Initialize Cn group	
	6	Initialize In group	
	7	Initialize OU group	
	8	Initialize CM group	
	9	Initialize AP group	
	12	Initialize Pr group	
	13	Initialize M2 group	
	14	Initialize Operation group	

PARAMETER LOCK

Use parameter lock to prevent unauthorized modification of parameter settings. To enable parameter lock, register and enter a user password first.

Pr. Group	Pr. Code	Name	Parameter Setting	Setting Range	Unit
dr	dr.94	Password registration	–	0–9999	–
	dr.95	Parameter lock password	–	0–9999	–

Pr. Code	Description
dr.94 Password Registration	Setting the Password. Follow the procedure below to register a password.
	1 Press the [ENT] key twice on dr.94 code.
	2 Set the desired password with the arrow keys.
	3 Press the [ENT] key twice. the display will return to dr.94.
dr.94 Password Change	To change the previously registered password, follow the steps below.
	1 Press the [PROG/ENT] key on dr.94 code. 0000 will be displayed.
	2 Use the arrow keys to enter the current password.
	3 Press the [PROG/ENT] key. The value should remain on the display.
	4 Set the new password with the arrow keys.
	5 Press the [PROG/ENT] key twice. The display will return to dr.94.
dr.95 Locking the Drive	To lock the drive, follow the steps below.
	1 Press the [PROG/ENT] key on dr.95 code. UL will be displayed. This means the drive is currently unlocked.
	2 Press the [PROG/ENT] key again to display 0000.
	3 Enter the password using the arrow keys.
	4 Press the [PROG/ENT] key. L will be displayed. This means the drive is locked. (If no password has been registered, drive remains unlocked and displays UL.)
dr.95 Unlocking the Drive	To unlock the drive, follow the steps below.
	1 Press the [PROG/ENT] key on dr.95 code. L will be displayed. This means the drive is currently locked.
	2 Press the [PROG/ENT] key again to display 0000.
	3 Enter the password using the arrow keys.
	4 Press the [PROG/ENT] key. UL will be displayed. This means the drive is unlocked.



CAUTION: IF THE PARAMETER VIEW LOCK AND PARAMETER LOCK FUNCTIONS ARE ENABLED, NO DRIVE OPERATION RELATED FUNCTION CHANGES CAN BE MADE. IT IS VERY IMPORTANT THAT YOU MEMORIZE THE PASSWORD.

CHANGED PARAMETER DISPLAY

This feature displays all the parameters that are different from the factory defaults. Use this feature to track changed parameters.

Pr. Group	Pr. Code	Name	Parameter Setting	Setting Range	Unit
dr	dr.89	Display changed parameter	0 View All	0–1	–

CHANGED PARAMETER DISPLAY SETTING DETAILS

Pr. Code	Description		
dr.89 Display changed parameter	Setting		Function
	0	View All	Display all parameters
	1	View Changed	Display changed parameters only

MULTI-FUNCTION IO TIMER SETTINGS

Set a multi-function input terminal to a timer and On/Off control the multi-function relay according to the timer settings.

Pr. Group	Pr. Code	Name	Parameter Setting		Setting Range	Unit
In	In.65–In.69	Px terminal configuration	38	Timer In	0–52	–
OU	OU.31	Multi-function Relay1 define	28	Timer Out	–	–
	OU.33	Multi-function Relay2 define				
	OU.55	Timer on delay	3.00		0.00–100	sec
	OU.56	Timer off delay	1.00		0.00–100	sec

TIMER SETTING DETAILS

Pr. Code	Description
In.65–69 Px Define	Choose one of the multi-function input terminals and change it to a timer terminal by setting it to 38 (Timer In).
OU.31 Relay1, OU.33 Relay2	Set multi-function output relay to be used as a timer to 28 (Timer out).
OU.55 TimerOn Delay, OU.56 TimerOff Delay	Input a signal (On) to the timer terminal to operate a timer output (Timer out) after the time set at OU.55 has passed. When the multi-function input terminal is off, multi-function output or relay turns off after the time set at OU.56.

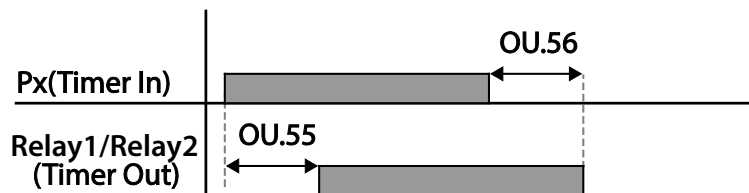

BRAKE CONTROL

Brake control is used to control the On/Off operation of electronic brake load system.

Pr. Group	Pr. Code	Name	Parameter Setting		Setting Range	Unit
Ad	Ad.41	Brake release current	50.0		0.0–180%	%
	Ad.42	Brake release delay time	1.00		0.0–10.0	sec
	Ad.44	Brake release forward frequency	1.00		0–Maximum frequency	Hz
	Ad.45	Brake release reverse frequency	1.00		0–Maximum frequency	Hz
	Ad.46	Brake engage delay time	1.00		0.00–10.00	sec
	Ad.47	Brake engage frequency	2.00		0–Maximum frequency	Hz
OU	OU.31	Multi-function Relay1 define	35	BR Control	–	–
	OU.33	Multi-function Relay2 define				

When brake control is activated, DC braking (Ad.12) at drive start and dwell operation (Ad.20–Ad.23) do not operate.

- **Brake release sequence:** During motor stop state, if an operation command is entered, the drive accelerates up to brake release frequency (Ad.44–Ad.45) in forward or in reverse direction. After reaching brake release frequency, if motor current reaches brake release current (BR Rls Curr), the output relay for brake control sends a release signal. Once the signal has been sent, acceleration will begin after maintaining frequency for brake release delay time (BR Rls Dly).
- **Brake engage sequence:** If a stop command is sent during operation, the motor decelerates. Once the output frequency reaches brake engage frequency (BR Eng Fr), the motor stops deceleration and sends out a brake engage signal to a preset output terminal. Frequency is maintained for the brake engage delay time (BR Eng Dly) and will become 0 afterwards. If DC braking time (Ad.15) and DC braking resistance (Ad.16) are set, drive output is blocked after DC braking. For DC braking, refer to "Stop After DC Braking" on page 4–76.

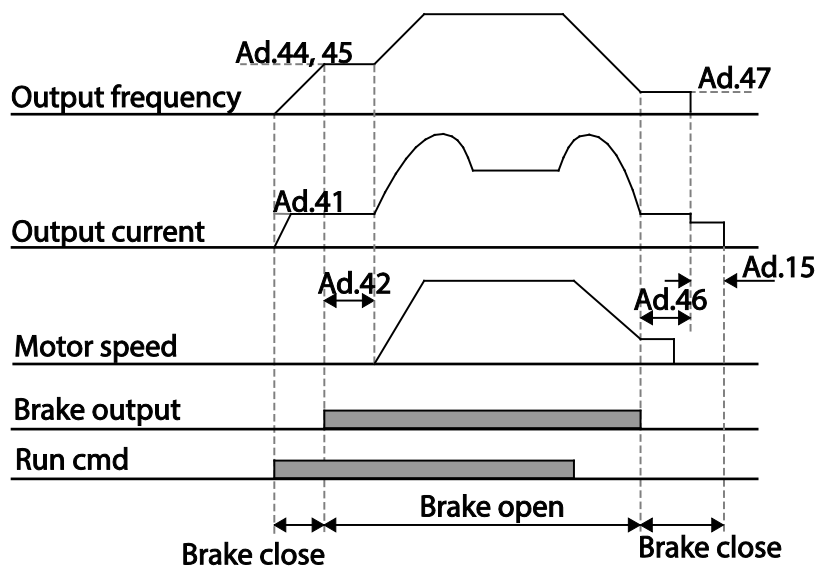

MULTI-FUNCTION OUTPUT RELAY ON/OFF CONTROL

Set reference values (on/off level) for analog input and output relays on/off status accordingly.

Pr. Group	Pr. Code	Name	Parameter Setting		Setting Range	Unit
Ad	Ad.66	Output terminal on/off control mode	1	V1	-	-
	Ad.67	Output terminal on level	90.00		Output terminal off level- 100.00%	%
	Ad.68	Output terminal off level	10.00		0.00-Output terminal on level	%
OU	OU.31	Multi-function Relay1 define	34	On/Off	-	-
	OU.33	Multi-function Relay2 define				

MULTI-FUNCTION OUTPUT ON/OFF CONTROL SETTING DETAILS

Pr. Code	Description
Ad.66 On/Off Ctrl Src	Select analog input On/Off control.
Ad.67 On-C Level , Ad.68 Off-C Level	Set On/Off level at the output terminal.

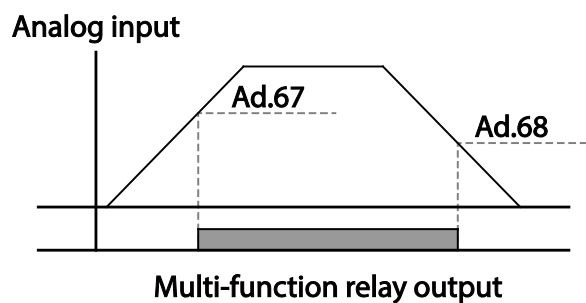

PRESS REGENERATION PREVENTION

Press regeneration prevention is used during press operations to prevent braking during the regeneration process. If motor regeneration occurs during a press operation, motor operation speed automatically goes up to avoid the regeneration zone.

Pr. Group	Pr. Code	Name	Parameter Setting		Setting Range	Unit
Ad	Ad.74	Select press regeneration prevention for press	0	No	0-1	-
	Ad.75	Press regeneration prevention operation voltage level	350V		230V: 300-400V	V
			700V		460V: 600-800V	
	Ad.76	Press regeneration prevention compensation frequency limit	1.00Hz		0.00- 10.00Hz	Hz
	Ad.77	Press regeneration prevention P gain	50.0%		0 .0- 100.0%	%
Ad.78	Press regeneration prevention I gain	500(ms)		20-30000ms	ms	

PRESS REGENERATION PREVENTION SETTING DETAILS

Pr. Code	Description
Ad.74 RegenAvd Sel	Frequent regeneration voltage from a press load during constant speed motor operation may force excessive work on the brake unit which may damage or shorten the brake life. To prevent this situation, select Ad.74 (RegenAvd Sel) to control DC link voltage and disable the brake unit operation.
Ad.75 RegenAvd Level	Set brake operation prevention level voltage when the DC link voltage goes up due to regeneration.
Ad.76 CompFreq Limit	Set alternative frequency width that can replace actual operation frequency during regeneration prevention.
Ad.77 RegenAvd Pgain Ad.78 RegenAvd Igain	To prevent regeneration zone, set P gain/I gain in the DC link voltage suppress PI controller.

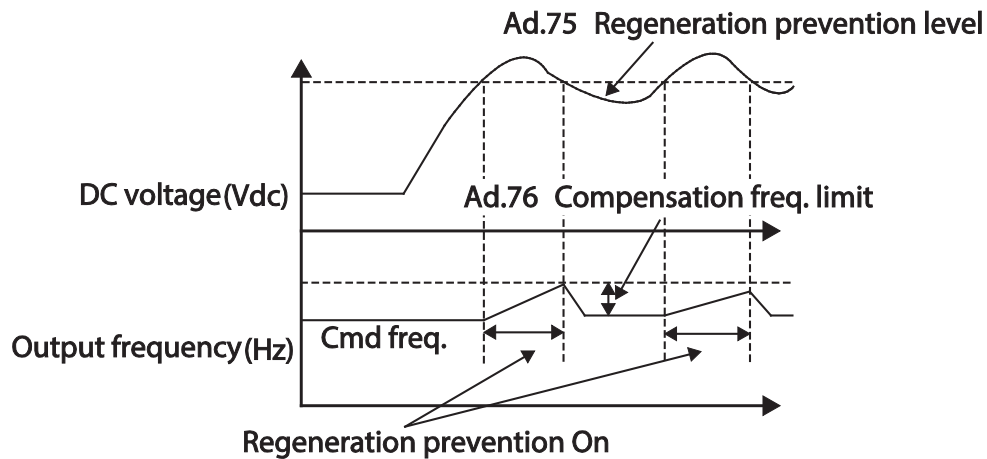

NOTE: Press regeneration prevention does not operate during accelerations or decelerations, but it only operates during constant speed motor operation. When regeneration prevention is activated, output frequency may change within the range set at Ad.76 (CompFreq Limit).

ANALOG OUTPUT

An analog output terminal provides output of 0–10V voltage.

VOLTAGE AND CURRENT ANALOG OUTPUT

An output type can be adjusted by selecting an output option at AO(Analog Output) terminal.

Pr. Group	Pr. Code	Name	Parameter Setting	Setting Range	Unit	
OU	OU.1	Analog output1 define	0	Frequency	0–15	–
	OU.2	Analog output1 gain	100.0		–1000.0–1000.0	%
	OU.3	Analog output1 bias	0.0		–100.0–100.0	%
	OU.4	Analog output1 filter	5		0–10000	ms
	OU.5	Analog constant output1	0.0		0.0–100.0	%
	OU.6	Analog output1 monitor	0.0		0.0–1000.0	%

VOLTAGE AND CURRENT ANALOG OUTPUT SETTING DETAILS

Pr. Code	Description		
OU.1 AO1 Mode	Select a constant value for output. The following example for output voltage setting.		
	Setting		
	Function		
	0	Frequency	Outputs operation frequency as a standard. 10V output is made from the frequency set at dr.20(Max Freq)
	1	Output Current	10V output is made from 200% of drive rated current.
	2	Output Voltage	Sets the outputs based on the drive output voltage. 10V output is made from a set voltage in bA.15 (Rated V). If 0V is set in bA.15, 230V/460V models output 10V based on the actual input voltages (240V and 480V respectively).
	3	DC Link Volt	Outputs drive DC link voltage as a standard. Outputs 10V when the DC link voltage is 410Vdc for 230V models, and 820Vdc for 460V models.
	4	Torque	Outputs the generated torque as a standard. Outputs 10V at 250% of motor rated torque.
	5	Output Power	Monitors output wattage. 200% of rated output is the maximum display voltage (10V).
	6	Idse	Outputs the maximum voltage at 200% of no load current. Outputs 0V during V/F operation or slip compensation operation since it is an output of the magnitude of the current on the magnetic flux portion.
	7	Iqse	Outputs the maximum voltage at 250% of rated torque current $= \sqrt{\frac{\text{rated torque current}}{\text{rated current}^2} - \text{no load current}^2}$
	8	Target Freq	Outputs set frequency as a standard. Outputs 10V at the maximum frequency (dr.20).
	9	Ramp Freq	Outputs frequency calculated with Acc/Dec function as a standard. May vary with actual output frequency. Outputs 10V.
	12	PID Ref Value	Outputs command value of a PID controller as a standard. Outputs approximately 6.6V at 100%.
	13	PID Fdb Value	Outputs feedback volume of a PID controller as a standard. Outputs approximately 6.6V at 100%.
14	PID Output	Outputs output value of a PID controller as a standard. Outputs approximately 10V at 100%.	
15	Constant	Outputs OU.5 (AO1 Const %) value as a standard.	

Pr. Code	Description															
OU.2 AO1 Gain, OU.3 AO1 Bias	<p>Adjusts output value and offset. If frequency is selected as an output item, it will operate as shown below.</p> $AO1 = \frac{Frequency}{MaxFreq} \times AO1\ Gain + AO1\ Bias$ <p>The graph below illustrates the analog voltage output (AO1) changes depend on OU.2 (AO1 Gain) and OU.3 (AO1 Bias) values. Y-axis is analog output voltage (0–10V), and X-axis is % value of the output item. Example, if the maximum frequency set at dr.20 (Max Freq) is 60Hz and the present output frequency is 30Hz, then the x-axis value on the next graph is 50%.</p> <div style="text-align: center;"> <table border="1" data-bbox="548 590 1308 1224"> <thead> <tr> <th colspan="2"></th> <th colspan="2">OU.2 AO1 Gain</th> </tr> <tr> <th colspan="2"></th> <th>100.0% (Factory default)</th> <th>80.0%</th> </tr> </thead> <tbody> <tr> <th rowspan="2">OU.3 AO1 Bias</th> <th>0.0% Factory default</th> <td data-bbox="727 663 1008 940"> </td> <td data-bbox="1008 663 1308 940"> </td> </tr> <tr> <th>20.0%</th> <td data-bbox="727 940 1008 1224"> </td> <td data-bbox="1008 940 1308 1224"> </td> </tr> </tbody> </table> </div>			OU.2 AO1 Gain				100.0% (Factory default)	80.0%	OU.3 AO1 Bias	0.0% Factory default			20.0%		
			OU.2 AO1 Gain													
		100.0% (Factory default)	80.0%													
OU.3 AO1 Bias	0.0% Factory default															
	20.0%															
OU.4 AO1 Filter	Set filter time constant on analog output.															
OU.5 AO1 Const %	If analog output at OU.1 (AO1 Mode) is set to 15(Constant), the analog voltage output is dependent on the set parameter values (0–100%).															
OU.6 AO1 Monitor	Monitors analog output value. Displays the maximum output voltage as a percentage (%) with 10V as the standard.															

DIGITAL OUTPUT**MULTI-FUNCTION OUTPUT RELAY SETTINGS**

Pr. Group	Pr. Code	Name	Parameter Setting		Setting Range	Unit
OU	OU.30	Fault output item	010*		–	bit
	OU.31	Multi-function Relay1 define	29	Trip	0–45	–
	OU.33	Multi-function Relay2 define	14	Run	0–45	–
	OU.41	Multi-function output monitor	–		00– 11	bit
	OU.57	Detection frequency	30.00		0.00–Maximum frequency	Hz
	OU.58	Detection frequency band	10.00			
In	In.65–In.69	Px terminal setting options	16	Exchange	–	–

*See "Bit Selection" on page 4–3 for details

MULTI-FUNCTION OUTPUT RELAY SETTING DETAILS

Pr. Code	Description
OU.31 Relay1	Set the Relay1 output multi-function selection. See "Digital Output OU.31/OU.33 Functions" on page 4–132.
OU.33 Relay2	Set the Relay2 output multi-function selection. See "Digital Output OU.31/OU.33 Functions" on page 4–132.
OU.41 Output	Indicates the status of OU.31 and OU.33 (On or Off). See "Bit Selection" on page 4–3 for details.
OU.57 FDT Freq OU.58 FDT Band	Reference OU.31/OU.33 FDT-x options 1,2,3,4,23 in the table below. When these options are used, set OU.57 FDT (Frequency), OU.58 (FDT Band) according to fault trip conditions.

Pr. Code	Digital Output OU.31/OU.33 Functions	
	Setting	Function
OU.31/ OU.33 Multi- function Selections	0	None No output signal.
	1	FDT-1 <p>Detects drive output frequency reaching the user set frequency. Outputs a signal when the absolute value (set frequency–output frequency) < detected frequency width/2. When detected frequency width is 10Hz (OU.58 FDT Band), FDT-1 output is as shown in the graph below.</p>
	2	FDT-2 <p>Outputs a signal when the user set frequency and detected frequency (OU.57 FDT Frequency) are equal, and fulfills FDT-1 condition at the same time. [Absolute value (set frequency–detected frequency) < detected frequency width/2]&[FDT-1]</p> <p>Detected frequency width is 10Hz (OU.58 FDT Band). When the detected frequency is set to 30Hz, FDT-2 output is as shown in the graph below.</p>
3	FDT-3 <p>Outputs a signal when the Absolute value (output frequency–operation frequency) < detected frequency width/2.</p> <p>Detected frequency width is OU.58 FDT Band (10Hz). When detected frequency (OU.57 FDT Frequency) is set to 30Hz, FDT-3 output is as shown in the graph below.</p>	

Pr. Code	Digital Output OU.31/OU.33 Functions	
	Setting	Function
OU.31/ OU.33 Multi- function Selections	4	<p>FDT-4</p> <p>Output signal can be separately set for acceleration and deceleration conditions.</p> <ul style="list-style-type: none"> • In acceleration: Operation frequency \geq Detected frequency • In deceleration: Operation frequency $>$ (Detected frequency - Detected frequency width/2) <p>Detected frequency width is 10Hz (OU.58 FDT Band). When detected frequency (OU.57 FDT Frequency) is set to 30Hz, FDT-4 output is as shown in the graph below.</p>
	5	<p>Overload</p> <p>Outputs a signal at motor overload.</p>
	6	<p>IOL</p> <p>Outputs a signal when a fault is triggered from a protective function operation by drive overload inverse proportion.</p>
	7	<p>Underload</p> <p>Outputs a signal at load fault warning.</p>
	8	<p>Fan Warning</p> <p>Outputs a signal at fan fault warning.</p>
	9	<p>Stall</p> <p>Outputs a signal when a motor is overloaded and stalled.</p>
	10	<p>Over voltage</p> <p>Outputs a signal when the drive DC link voltage rises above the protective operation voltage.</p>
	11	<p>Low Voltage</p> <p>Outputs a signal when the drive DC link voltage drops below the low voltage protective level.</p>
	12	<p>Over Heat</p> <p>Outputs signal when the drive overheats.</p>
	13	<p>Lost command</p> <p>Outputs a signal when there is a loss of analog input terminal and RS-485 communication command at the terminal block. Outputs a signal when communication power and expansion an I/O power card is installed, and also outputs a signal when losing analog input and communication power commands.</p>
	14	<p>RUN</p> <p>Outputs a signal when operation command is entered and the drive outputs voltage. No signal output during DC braking.</p>
	15	<p>Stop</p> <p>Outputs a signal at operation command off, and when there is no drive output voltage.</p>
	16	<p>Steady</p> <p>Outputs a signal in steady operation.</p>
	17	<p>Drive line</p> <p>Outputs a signal while the motor is driven by the drive line.</p>
	18	<p>Comm line</p> <p>Outputs a signal while the motor is driven by a commercial power source. For details, refer to "Supply Power Transition" on page 4-120.</p>
	19	<p>Speed search</p> <p>Outputs a signal during drive speed search operation. For details, refer to "Speed Search Operation" on page 4-113.</p>
	21	<p>Regeneration</p> <p>Outputs signal if the motor is operating under regeneration mode. Braking resistance is activated when the drive DC voltage is higher than the voltage set in Ad-79 and this feature operates only when the drive is operating.</p>
22	<p>Ready</p> <p>Outputs signal when the drive is in stand by operation and ready to receive an external operation command.</p>	
23	<p>FDT-5 (Zspd)</p> <p>Outputs signal that is lower than the frequency set in OU.57 and OU.58.</p>	

Pr. Code	Digital Output OU.31/OU.33 Functions		
	Setting	Function	
OU.31/ OU.33 Multi- function Selections	28	Timer Out	A timer function to operate terminal output after a certain time by using multi-function terminal block input. For more details, refer to "Multi-function IO Timer Settings" on page 4-125.
	29	Trip	Outputs a signal after a fault trip Refer to "Multi-function Output On/Off Control Setting Details" on page 4-127.
	31	DB Warn %ED	Refer to "Dynamic Braking" on page 4-147.
	34	On/Off Control	Outputs a signal using an analog input value as a standard. Refer to "Multi-function Output On/Off Control Setting Details" on page 4-127.
	35	BR Control	Outputs a brake release signal. Refer to "Brake Control" on page 4-126.
	38	Fire Mode	Outputs a signal when the drive is operating in Fire Mode. Refer to Fire Mode Operation on page 4-82.
	40	KEB Operating	This outputs when the energy buffering operation is started because of low voltage of the drive's DC power section due to a power failure on the input power. (This outputs in the energy buffering state before the input power restoration regardless of KEB-1 and KEB-2 mode settings.)
	42	Minor Fault	Outputs signal when drive is under warning status.
	43	Prt Trq Det 1	Set torque detection protection action.
	44	Prt Trq Det 2	Set torque detection protection action.
45	PID Sleep	Outputs signal when drive is under PID Sleep status.	

FAULT TRIP OUTPUT USING MULTI-FUNCTION OUTPUT RELAYS

The drive can output fault trip state using multi-function output Relay1 and Relay2.

Pr. Group	Pr. Code	Name	Parameter Setting		Setting Range	Unit
OU	OU.30	Fault trip output mode	010		–	bit
	OU.31	Multi-function Relay1 define	29	Trip	0–45	–
	OU.33	Multi-function Relay2 define	14	Run	0–45	–
	OU.53	Fault trip output on delay	0.00		0.00–100.00	sec
	OU.54	Fault trip output off delay	0.00		0.00–100.00	sec

Fault Trip Output by Multi-function Output Relay – Setting Details

Pr. Code	Description																			
OU.30 Trip Out Mode	Fault trip relay operates based on the fault trip output settings. When a fault trip occurs in the drive, the relevant terminal and relay will operate. Depending on the fault trip type, terminal and relay operation can be configured as shown in the table below. *See "Bit Selection" on page 4–3 for details.																			
	After selecting the multi-function relay to use as the trip output, select 29 (Trip Mode) in OU.31, 33. If the trip occurs from the drive, the applicable multi-function relay will be activated. Activation status of multi-function relay can be set up as below depending on the trip type.																			
	<table border="1"> <thead> <tr> <th colspan="3">Setting</th> <th rowspan="2">Function</th> </tr> <tr> <th>bit3</th> <th>bit2</th> <th>bit1</th> </tr> </thead> <tbody> <tr> <td></td> <td></td> <td>X</td> <td>Operates when low voltage fault trips occur</td> </tr> <tr> <td></td> <td>X</td> <td></td> <td>Operates when fault trips other than low voltage occur</td> </tr> <tr> <td>X</td> <td></td> <td></td> <td>Operates when auto restart fails (Pr.8 and Pr.9)</td> </tr> </tbody> </table>	Setting			Function	bit3	bit2	bit1			X	Operates when low voltage fault trips occur		X		Operates when fault trips other than low voltage occur	X			Operates when auto restart fails (Pr.8 and Pr.9)
	Setting			Function																
	bit3	bit2	bit1																	
			X	Operates when low voltage fault trips occur																
	X		Operates when fault trips other than low voltage occur																	
X			Operates when auto restart fails (Pr.8 and Pr.9)																	
OU.31 Relay1	Set the Relay1 output multi-function selection.																			
OU.33 Relay2	Set the Relay2 output multi-function selection.																			
OU.53 Trip Out On Dly, OU.54 Trip Out Off Dly	If a fault trip occurs, trip relay or multi-function output operates after the time delay set in OU.53. Terminal is off with the input initialized after the time delay set in OU.54.																			

MULTI-FUNCTION OUTPUT RELAY DELAY TIME SETTINGS

Set on-delay and off-delay times separately to control the relay operation times. The delay time set at codes OU.50–OU.51 applies to multi-function output Relay1 and Relay2, except when the multi-function output is set to fault trip mode.

Pr. Group	Pr. Code	Name	Parameter Setting	Setting Range	Unit
OU	OU.50	Multi-function output On delay	0.00	0.00–100.00	s
	OU.51	Multi-function output Off delay	0.00	0.00–100.00	s
	OU.52	Select multi-function output terminal	00*	00–11	bit

*See "Bit Selection" on page 4–3 for details

Output Relay Delay Time Setting Details

Pr. Code	Description
OU.52 DO NC/NO Sel	Select the contact type of Relay1 and Relay2. By setting the relevant bit to 0, it will operate A terminal (Normally Open), and setting it to 1 will operate B terminal (Normally Closed).

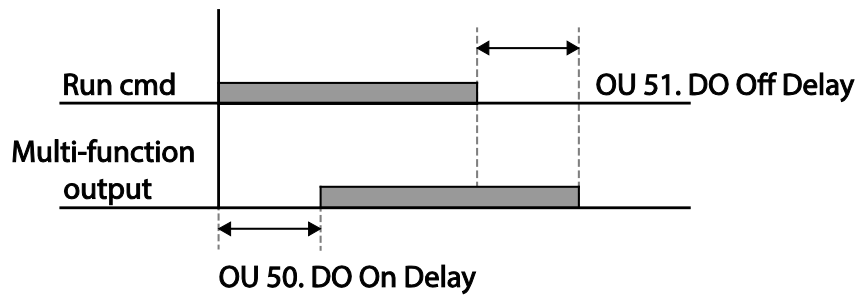

BASE BLOCK

This feature is used when output is blocked while operating the drive or when the multi-function relay must maintain the operating status by blocking output while stopping. If the multi-function signal set as base block is entered during operation, the motor will run freely. If the base block signal is disabled, speed search operation will start with the value set in Cn.72–Cn.75 even if the Cn.71 speed search operation selection parameter is not activated. The output being blocked by the base block feature does not have effect on the multi-function relay and will be recognized as being in operation even if there is no drive output.

Pr. Group	Pr. Code	Name	Parameter Setting		Setting Range	Unit
In	In.65–In.69	Px terminal setting options	33	Base Block	1–52	–
OU	OU.31	Multi-function Relay1 define	14	Run	1–44	–
	OU.33	Multi-function Relay2 define			–	–

Base Block Operation Setting Details

Pr. Code	Description
In.65–In.69 Px define	Select the multi-function input terminal to receive the base block signal and set the applicable terminal to 33 (Base Block).
OU.31 Relay1 OU.33 Relay2	Set the multi-function relay terminal to 14 (Run). If the operation command is given, the drive will accelerate up to the command frequency. If the base block signal is entered during acceleration or constant speed operation, the drive will block the output immediately and start free-run. If the base block signal is disabled, the drive will accelerate as a speed search operation until it reaches the command frequency, without receiving a specific reset command. "bb" will be displayed on the keypad during the base block operation. Disabling the base block will reset the drive automatically and the base block will not be recorded in the trip history.

LOAD SPEED DISPLAY SETTING

These parameters adjust the display value in the operation menu rpm parameter. Use this parameter to scale or show a different value based on the drive RPM.

Pr. Group	Pr. Code	Name	Parameter Setting		Setting Range	Unit
Ad	Ad.61	Rotation count speed gain (RPM Display)	–	100.0	1–6000.0%	%
M2	M2.40					

Parameters adjust the RPM display value based on this formula:

$$RPM\ DISPLAY\ X\ <Ad.61\ VALUE>\%$$

Example:

If the line speed or process value is "300" at 800rpm, set the following:

$$Ad.61 = 37.5\%$$

Now the operation menu monitoring parameter rpm is displayed on the keypad as 300 instead of 800 (rpm).

LEARNING PROTECTION FEATURES

Protection features provided by the ACG series drive are categorized into two types: protection from overheating damage to the motor, and protection against the drive malfunction.

MOTOR PROTECTION

ELECTRONIC THERMAL MOTOR OVERHEATING PREVENTION (ETH)

ETH is a protective function that uses the output current of the drive without a separate temperature sensor, to predict a rise in motor temperature to protect the motor based on its heat characteristics.

Pr. Group	Pr. Code	Name	Parameter Setting		Setting range	Unit
Pr	Pr.40	Electronic thermal prevention fault trip selection	0	None	0–2	–
	Pr.41	Motor cooling fan type	0	Self-cool	–	–
	Pr.42	Electronic thermal one minute rating	150		120–200	%
	Pr.43	Electronic thermal prevention continuous rating	120		50–150	%

ELECTRONIC THERMAL (ETH) PREVENTION FUNCTION SETTING DETAILS

Pr. Code	Description												
Pr.40 ETH Trip Sel	Electronic Thermal (ETH) can be selected to provide motor thermal protection.												
	Setting	Function											
	0	None	The ETH function is not activated.										
	1	Free-Run	The drive output is blocked. The motor coasts to a halt (free-run).										
	2	Dec	The drive decelerates the motor to a stop.										
Pr.41 Motor Cooling	Select the drive mode of the cooling fan, attached to the motor.												
	Setting	Function											
	0	Self-cool	As the cooling fan is connected to the motor axis, the cooling effect varies, based on motor speed. Most universal induction motors have this design.										
	1	Forced-cool	Additional power is supplied to operate the cooling fan. This provides extended operation at low speeds. Motors designed for drives typically have this design.										
	<p>Continuous rated current (%)</p> <table border="1"> <caption>Data for Pr.41 Motor Cooling Graph</caption> <thead> <tr> <th>Frequency (Hz)</th> <th>Pr.41=0 Current (%)</th> <th>Pr.41=1 Current (%)</th> </tr> </thead> <tbody> <tr> <td>0</td> <td>65</td> <td>-</td> </tr> <tr> <td>20</td> <td>95</td> <td>95</td> </tr> <tr> <td>60</td> <td>-</td> <td>100</td> </tr> </tbody> </table>		Frequency (Hz)	Pr.41=0 Current (%)	Pr.41=1 Current (%)	0	65	-	20	95	95	60	-
Frequency (Hz)	Pr.41=0 Current (%)	Pr.41=1 Current (%)											
0	65	-											
20	95	95											
60	-	100											
Pr.42 Electronic thermal one minute rating	The amount of input current that can be continuously supplied to the motor for 1 minute, based on the motor-rated current (bA.13).												
Pr.43 Electronic thermal prevention continuous rating	Sets the amount of current with the ETH function activated. The range below details the set values that can be used during continuous operation without the protection function.												
	<table border="1"> <caption>Data for Pr.43 Graph</caption> <thead> <tr> <th>ETH trip time (seconds)</th> <th>Current</th> </tr> </thead> <tbody> <tr> <td>60</td> <td>Pr.42</td> </tr> <tr> <td>Pr.43</td> <td>-</td> </tr> </tbody> </table>		ETH trip time (seconds)	Current	60	Pr.42	Pr.43	-					
ETH trip time (seconds)	Current												
60	Pr.42												
Pr.43	-												

OVERLOAD EARLY WARNING AND TRIP

A warning or fault ‘trip’ (cutoff) occurs when the motor reaches an overload state, based on the motor’s rated current. The amount of current for warnings and trips can be set separately.

Pr. Group	Pr. Code	Name	Parameter Setting		Setting range	Unit
Pr	Pr.4	Load level setting	1	Heavy Load (HD)	–	–
	Pr.17	Overload warning selection	1	Yes	0–1	–
	Pr.18	Overload warning level	150		30–180	%
	Pr.19	Overload warning time	10.0		0–30	s
	Pr.20	Motion at overload trip	1	Free-Run	–	–
	Pr.21	Overload trip level	180		30–200	%
	Pr.22	Overload trip time	60.0		0–60.0	s
OU	OU.31	Multi-function Relay1 define	5	Over Load	–	–
	OU.33	Multi-function Relay2 define				

Overload Early Warning and Trip Setting Details

Pr. Coden	Description
Pr.4 Load Duty	Select the load level.
	Setting Function
	0 Normal Load (ND) Used in variable torque applications, like fans and pumps (overload tolerance: 120% of rated underload current for 1 minute).
	1 Heavy Load (HD) Used in heavy loads, like hoists, cranes, and parking devices (overload tolerance: 150% of rated heavy load current for 1 minute).
Pr.17 OL Warn Select	If the overload reaches the warning level, the multi-function output relays are used to output a warning signal. If 1 (Yes) is selected, it will operate. If 0 (No) is selected, it will not operate.
Pr.18 OL Warn Level, Pr.19 OL Warn Time	When the input current to the motor is greater than the overload warning level (OL Warn Level) and continues at that level during the overload warning time (OL Warn Time), the multi-function output (Relay1, Relay2) sends a warning signal. When Over Load is selected at OU.31 and OU.33, the multi-function relay outputs a signal. The signal output does not block the drive output.
Pr.20 OL Trip Select	Select the drive protective action in the event of an overload fault trip.
	Setting Function
	0 None No protective action is taken.
	1 Free-Run In the event of an overload fault, drive output is blocked and the motor will free-run due to inertia.
2 Dec If a fault trip occurs, the motor decelerates and stops.	
Pr.21 OL Trip Level, Pr.22 OL Trip Time	When the current supplied to the motor is greater than the preset value at the overload trip level (OL Trip Level) and continues to be supplied during the overload trip time (OL Trip Time), the drive output is either blocked according to the preset mode from Pr.17 or slows to a stop after deceleration.

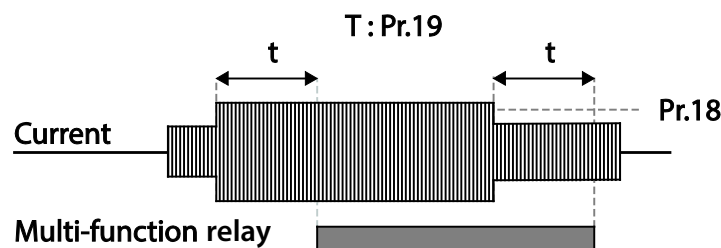



NOTE: Overload warnings warn of an overload before an overload fault trip occurs. The overload warning signal may not work in an overload fault trip situation, if the overload warn level (OL Warn Level) and the overload warn time (OL Warn Time) are set higher than the overload trip level (OL Trip Level) and overload trip time (OL Trip Time).

STALL PREVENTION AND FLUX BRAKING

The stall prevention function is a protective function that prevents motor stall caused by overloads. If a motor stall occurs due to an overload, the drive operation frequency is adjusted automatically. When stall is caused by overload, high currents are induced in the motor may cause motor overheat or damage the motor and interrupt operation of the motor-driven devices.

Flux braking is used to gain the optimum deceleration time without the braking resistance. If the deceleration time is too short, over voltage trip may occur due to the regeneration energy from the motor. When using flux braking, ideal deceleration time may be gained without over voltage trip because regenerative energy is expended at the motor. Flux braking stops operating when the control mode is IM Sensorless.

Pr. Group	Pr. Code	Name	Parameter Setting		Setting range	Unit
Pr	Pr.50	Stall prevention and flux braking	0000*		–	bit
	Pr.51	Stall frequency 1	60.00		Start frequency–Stall Freq 1	Hz
	Pr.52	Stall level 1	180		30–250	%
	Pr.53	Stall frequency 2	60.00		Stall Freq 1–Stall Freq 3	Hz
	Pr.54	Stall level 2	180		30–250	%
	Pr.55	Stall frequency 3	60.00		Stall Freq 2–Stall Freq 4	Hz
	Pr.56	Stall level 3	180		30–250	%
	Pr.57	Stall frequency 4	60.00		Stall Freq 3–Maximum frequency	Hz
OU	OU.31	Multi-function Relay1	9	Stall	–	–
	OU.33	Multi-function Relay2				

*See "Bit Selection" on page 4–3 for details

Stall Prevention Function and Flux Braking Setting Details

Pr. Code	Description				
Pr.50 Stall Prevent	Stall prevention can be configured for acceleration, deceleration, or while operating a motor at constant speed. When the top LED segment is on, the corresponding bit is set. When the bottom LED segment is on, the corresponding bit is off. *See "Bit Selection" on page 4–3 for details				
	Configuration				
	bit4	bit3	bit2	bit1	Function
				X	Stall protection during acceleration
			X		Stall protection while operating at a constant speed
		X			Stall protection during deceleration
	X				Flux braking during deceleration
	Setting				Function
	0001	Stall protection during acceleration		If drive output current exceeds the preset stall level (Pr.52, 54, 56, 58) during acceleration, the motor stops accelerating and starts decelerating. If current level stays above the stall level, the motor decelerates to the start frequency (dr.19). If the current level causes deceleration below the preset level while operating the stall protection function, the motor resumes acceleration.	
	0010	Stall protection while operating at constant speed		Similar to stall protection function during acceleration, the output frequency automatically decelerates when the current level exceeds the preset stall level while operating at constant speed. When the load current decelerates below the preset level, it resumes acceleration. During acceleration, the operation will follow the stall protection settings for acceleration.	
	0100	Stall protection during deceleration		The drive decelerates and keeps the DC link voltage below a certain level to prevent an over voltage fault trip during deceleration. As a result, deceleration times can be longer than the set time depending on the load.	
	1000	Flux braking during deceleration		When using flux braking, deceleration time may be reduced because regenerative energy is expended at the motor.	
	1100	Stall protection and flux braking during deceleration		Stall protection and flux braking operate together during deceleration to achieve the shortest and most stable deceleration performance.	

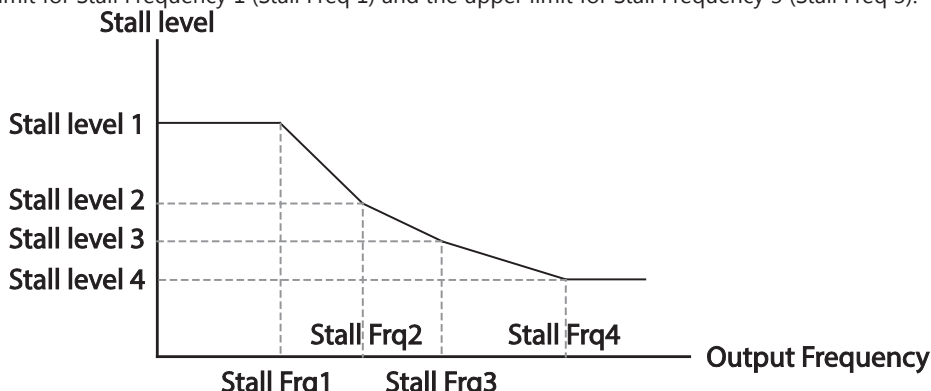
Pr. Code	Description
Pr.51 – Pr.58 Stall Freq 1-4 Stall Level 1-4	<p>Additional stall protection levels can be configured for different frequencies, based on the load type. As shown in the graph below, the stall level can be set above the base frequency. The lower and upper limits are set using numbers that correspond in ascending order. For example, the range for Stall Frequency 2 (Stall Freq 2) becomes the lower limit for Stall Frequency 1 (Stall Freq 1) and the upper limit for Stall Frequency 3 (Stall Freq 3).</p> 



NOTE: Stall protection and flux braking operate together only during deceleration. Turn on the third and fourth bits of Pr.50 (Stall Prevention) to achieve the shortest and most stable deceleration performance without triggering an overvoltage fault trip for loads with high inertia and short deceleration times. Do not use this function when frequent deceleration of the load is required, as the motor can overheat and may be damaged easily.

When operating Brake resistor, the motor may vibrate under the Flux braking operation. In this case, please turn off the Flux braking (Pr.50).



CAUTION: Use CAUTION WHEN DECELERATING WHILE USING STALL PROTECTION AS DEPENDING ON THE LOAD, THE DECELERATION TIME CAN TAKE LONGER THAN THE TIME SET. ACCELERATION STOPS WHEN STALL PROTECTION OPERATES DURING ACCELERATION. THIS MAY MAKE THE ACTUAL ACCELERATION TIME LONGER THAN THE PRESET ACCELERATION TIME.

WHEN THE MOTOR IS OPERATING, STALL LEVEL 1 APPLIES AND DETERMINES THE OPERATION OF STALL PROTECTION.

DRIVE AND SEQUENCE PROTECTION**INPUT/OUTPUT OPEN-PHASE PROTECTION**

Open-phase protection is used to prevent overcurrent levels induced at the drive inputs due to an open-phase within the input power supply. Open-phase output protection is also available. An open-phase at the connection between the motor and the drive output may cause the motor to stall, due to a lack of torque.

Pr. Group	Pr. Code	Name	Parameter Setting	Setting range	Unit
Pr	Pr.5	Input/output open-phase protection	00*	–	bit
	Pr.6	Open-phase input voltage band	15	1–100V	V

*See "Bit Selection" on page 4–3 for details

Input and Output Open-phase Protection Setting Details

Pr. Code	Description		
Pr.5 Phase Loss Chk, Pr.6 IPO V Band	When open-phase protection is operating, input and output configurations are displayed differently. When the top LED segment is On, the corresponding bit is set to On. When the bottom LED segment is On, the corresponding bit is set to Off. *See "Bit Selection" on page 4–3 for details		
	Setting		Function
	Bit 2	Bit 1	
		X	Output open-phase protection
	X		Input open-phase protection
	Initial values by each product on input voltage range during open-phase are shown as below.		
	Items	Initial Value	Unit
	230V and 460V: 0.5–3 hp	15	V
	230V and 460V: 5–10 hp	13	
	230V and 460V: 15 hp and up	15	

EXTERNAL TRIP SIGNAL

Set one of the multi-function input terminals to 4 (External Trip) to allow the drive to stop operation by using external signals.

Pr. Group	Pr. Code	Name	Parameter Setting		Setting range	Unit
In	In.65–In.69	Px terminal setting options	4	External Trip	0–52	–
	In.87	Multi-function input contact selection	00000*		–	bit

*See "Bit Selection" on page 4–3 for details

External Trip Signal Setting Details

Pr. Code	Description					
In.87 DI NC/NO Sel	Selects the type of input contact. If the mark of the switch is at the bottom (0), it operates as an A contact (Normally Open). If the mark is at the top (1), it operates as a B contact (Normally Closed). The corresponding terminals for each bit are as follows:					
	Bit	5	4	3	2	1
	Terminal	P5	P4	P3	P2	P1

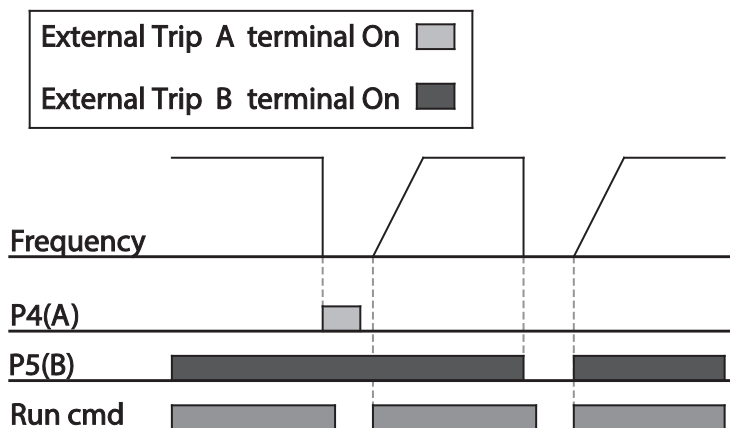

DRIVE OVERLOAD PROTECTION

When the drive input current exceeds the rated current, a protective function is activated to prevent damages to the drive based on inverse proportional characteristics.

Pr. Group	Pr. Code	Name	Parameter Setting		Setting range	Unit
OU	OU.31	Multi-function Relay1	6	IOL	–	–
	OU.33	Multi-function Relay2				



NOTE: A warning signal output can be provided in advance by the multi-function output relay before the drive overload protection function (IOL) operates. When the overcurrent time reaches 60% of the allowed overcurrent (150%, 1 min), a warning signal output is provided (signal output at 150%, 36sec).

SPEED COMMAND LOSS

When setting operation speed using an analog input, serial/ethernet communications, or the keypad, speed command loss setting can be used to select the drive operation for situations when the speed command is lost due to the disconnection of signal cables.

Pr. Group	Pr. Code	Name	Parameter Setting		Setting range	Unit
Pr	Pr.12	Speed command loss operation mode	1	Free-Run	–	–
	Pr.13	Time to determine speed command loss	1.0		0.1–120	s
	Pr.14	Operation frequency at speed command loss	0.00		Start frequency–Max. frequency	Hz
	Pr.15	Analog input loss decision level	0	Half of x1	–	–
OU	OU.31	Multi-function Relay1	13	Lost Command	–	–
	OU.33	Multi-function Relay2				

Speed Command Loss Setting Details

Pr. Code	Description		
Pr.12 Lost Cmd Mode	In situations when speed commands are lost, the drive can be configured to operate in a specific mode:		
	Setting	Function	
	0	None	The speed command immediately becomes the operation frequency without any protection function.
	1	Free-Run	The drive blocks output. The motor performs in free-run condition.
	2	Dec	The motor decelerates and then stops at the time set at Pr.7 (Trip Dec Time).
	3	Hold Input	The drive calculates the average input value for 10 seconds before the loss of the speed command and uses it as the speed reference.
	4	Hold Output	The drive calculates the average output value for 10 seconds before the loss of the speed command and uses it as the speed reference.
Pr.15 AI Lost Level, Pr.13 Lst Cmd Time	Configure the voltage and decision time for speed command loss when using analog input.		
	Setting	Function	
	0	Half of x1	Based on the values set at In.8 and In.12, protective operation starts when the input signal is reduced to half of the initial value of the analog input set using the speed command (Frq code of Operation group) and it continues for the time (speed loss decision time) set at Pr. 13 (Lost Cmd Time). For example, set the speed command to 2 (V1) at the Frq code in the Operation group, and In.6 (V1 Polarity) to 0 (Unipolar). When the voltage input drops to less than half of the value set at In.8 (V1 Volt x 1), the protective function is activated.
1	Below x1	The protective operation starts when the signal becomes smaller than the initial value of the analog input set by the speed command and it continues for the speed loss decision time set at Pr.13 (Lost Cmd Time). Codes In.8 and In.12 are used to set the standard values.	
Pr.14 Operation frequency at speed command loss	In situations where speed commands are lost, set the operation mode (Pr.12 Lost Cmd Mode) to 5 (Lost Preset). This operates the protection function and sets the frequency so that the operation can continue.		

Set Pr.15 (AI Lost Level) to 1 (Below x 1), Pr.12 (Lost Cmd Mode) to 2 (Dec), and Pr.13 (Lost Cmd Time) to 5 sec. Then it operates as follows:

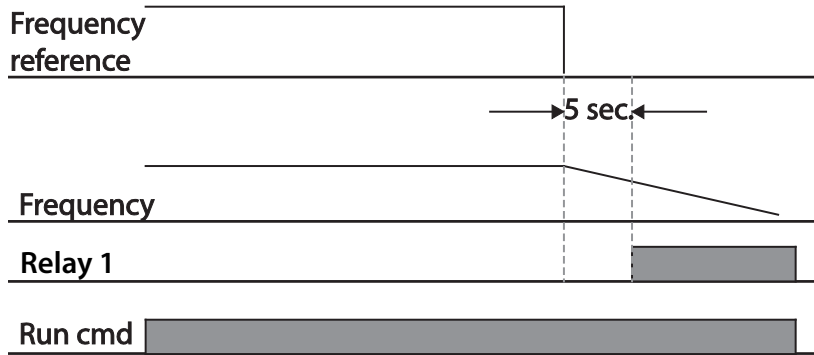

NOTE: If speed command is lost while using communication options or the integrated RS-485 communication, the protection function operates after the command loss decision time set at Pr.13 (Lost Cmd Time) is passed.

DYNAMIC BRAKING

DYNAMIC BRAKING (DB) RESISTOR CONFIGURATION

For ACG series, the braking resistor circuit is integrated inside the drive. For Dynamic braking with external resistor, set the desired turn on level with AD.79. Ensure AD.74=0. Monitor the DC bus voltage by parameter dCL in the operation menu and check voltage on terminals B1/B2 (0.5–10 hp) or P2/B (15–30 hp) to verify activation to brake resistor.

Pr.66 is for setup of a warning signal if the braking is being used too frequently.

Pr. Group	Pr. Code	Name	Parameter Setting		Setting range	Unit
Pr	Pr.66	Braking resistor configuration	10		0–30	%
OU	OU.31	Multi-function Relay1 item	31	DB Warn %ED	–	–
	OU.33	Multi-function Relay2 item				
Ad	Ad.74	Selection of regeneration evasion function for press	0	No	0–1	–
	Ad.79	DB Unit turn on voltage level	230V 460V	390V 780V	350–400V 600–800V	V

Dynamic Braking Resistor Setting Details

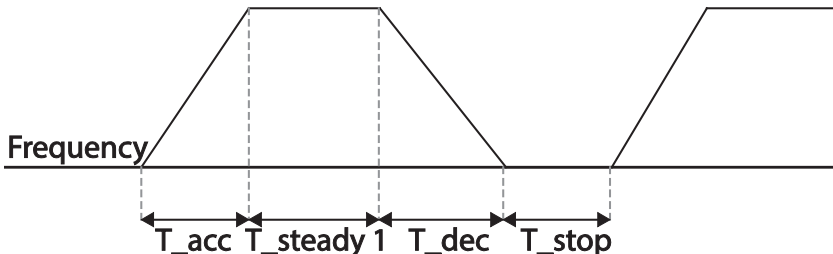
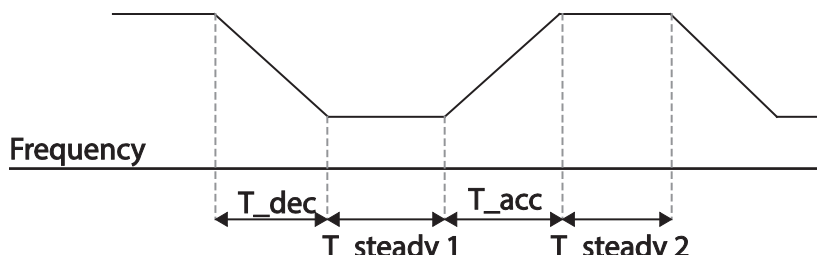
Pr. Code	Description
<p>Pr.66 DB Warn %ED</p>	<p>Set the amount of braking resistor (%ED: Duty cycle) for use. Braking resistor configuration sets the rate at which the braking resistor operates for one operation cycle. The maximum time for continuous braking is 15 sec and the braking resistor signal is not output from the drive after the 15 sec period has expired. The time until braking resistance is available again after continuous use of braking resistance for 15 seconds is calculated as below.</p> $T = \frac{(100\% - \%ED) \times 15}{\%ED} \text{ [s]}$ <p>If the braking resistor usage rate is set to 0%, braking resistance can be used without usage rate restriction. However, precaution is necessary since there is risk of fire if the braking resistance usage is higher than the power consumption of braking resistance. An example of braking resistor set up is as follows:</p> <p>Example 1</p> $\%ED = \frac{T_{dec}}{T_{acc} + T_{steady} + T_{dec} + T_{stop}} \times 100\%$  <p>Example 2</p> $\%ED = \frac{T_{dec}}{T_{dec} + T_{steady1} + T_{acc} + T_{steady2}} \times 100\%$  <ul style="list-style-type: none"> • T_{acc}: Acceleration time to set frequency • T_{steady}: Constant speed operation time at set frequency • T_{dec}: Deceleration time to a frequency lower than constant speed operation or the stop time from constant speed operation frequency • T_{stop}: Stop time until operation resumes



CAUTION: DO NOT SET THE BRAKING RESISTOR TO EXCEED THE RESISTOR'S POWER RATING. IF OVERLOADED, IT CAN OVERHEAT AND CAUSE A FIRE. WHEN USING A RESISTOR WITH A HEAT SENSOR, THE SENSOR OUTPUT CAN BE USED AS AN EXTERNAL TRIP SIGNAL FOR THE DRIVE'S MULTI-FUNCTION INPUT.

UNDER LOAD FAULT TRIP AND WARNING

Pr. Group	Pr. Code	Name	Parameter Setting		Setting range	Unit
Pr	Pr.4	Load level setting	0	Normal Load (ND)	–	–
	Pr.25	Under load warning selection	1	Yes	0–1	–
	Pr.26	Under load warning time	10.0		0–600	sec
	Pr.27	Under load trip selection	1	Free-Run	–	–
	Pr.28	Under load trip timer	30.0		0–600	sec
	Pr.29	Under load upper limit level	30		10–100	%
	Pr.30	Under load lower limit level	30		10–100	%

Under Load Trip and Warning Setting Details

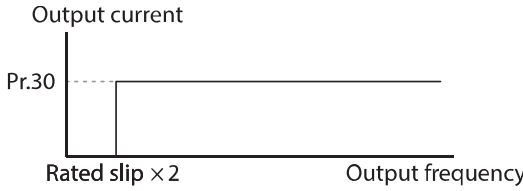
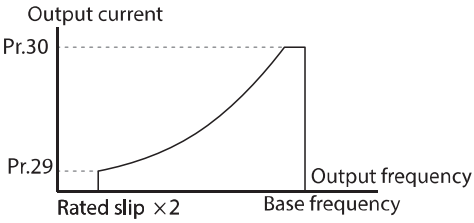
Pr. Code	Description
Pr.27 UL Trip Sel	Sets the occurrence of the under load trip. If set to 0 (None), the underload fault trip is not detected. If set to 1 (Free-Run), the output is blocked in an underload fault trip situation. If set to 2 (Dec), the motor decelerates and stops when an underload trip occurs. If set to 3 (Underload Sleep), When PID operation, drive will start PID Sleep operation in underload trip situation. and according to PID Wake Up setting, it will start Wake Up operation.
Pr.25 UL Warn Sel	Sets the underload warning options. Set to 1(Yes) and set the multi-function output relay (at OU.31 and 33) to 7 (Underload). The warning signals are output when an underload condition arises.
Pr.26 UL Warn Time, Pr.28 UL Trip Time	The protection function operates when the underload level condition explained above is maintained for a set warning time or fault trip time. This function does not operate if energy-saving operation is activated at Ad.50 (E-Save Mode).
Pr.29 UL LF Level Pr.30 UL BF Level	<p>Setting Heavy Load (HD)</p> <ul style="list-style-type: none"> Do not support Pr.29. At Pr.30, the underload level is decided based on the motor’s rated current.  <p>Setting Normal Load (ND)</p> <ul style="list-style-type: none"> At Pr.29, the under load rate is decided based on twice the operation frequency of the motor’s rated slip speed (bA.12 Rated Slip). At Pr.30, the under load rate is decided based on the base frequency set at dr.18 (Base Freq). An upper limit and lower limit is based on the drive’s rated current. 

FAN FAULT DETECTION

Pr. Group	Pr. Code	Name	Parameter Setting	Setting range	Unit
Pr	Pr.79	Cooling fan fault selection	0	Trip	–
OU	OU.31	Multi-function Relay1	8	FAN Warning	–
	OU.33	Multi-function Relay2			

Fan Fault Detection Setting Details

Pr. Code	Description						
Pr.79 FAN Trip Mode	Set the cooling fan fault mode.						
	<table border="1"> <thead> <tr> <th>Setting</th> <th>Function</th> </tr> </thead> <tbody> <tr> <td>0</td> <td>Trip The drive output is blocked and the fan trip is displayed when a cooling fan error is detected.</td> </tr> <tr> <td>1</td> <td>Warning When OU.33 (Relay2) and OU.31 (Relay1) are set to 8 (FAN Warning), the fan error signal is output and the operation continues.</td> </tr> </tbody> </table>	Setting	Function	0	Trip The drive output is blocked and the fan trip is displayed when a cooling fan error is detected.	1	Warning When OU.33 (Relay2) and OU.31 (Relay1) are set to 8 (FAN Warning), the fan error signal is output and the operation continues.
	Setting	Function					
0	Trip The drive output is blocked and the fan trip is displayed when a cooling fan error is detected.						
1	Warning When OU.33 (Relay2) and OU.31 (Relay1) are set to 8 (FAN Warning), the fan error signal is output and the operation continues.						
OU.31 Relay1 OU.33 Relay2	When the code value is set to 8 (FAN Warning), the fan error signal is output and operation continues. However, when the drive inside temperature rises above a certain level, output is blocked due to activation of overheat protection.						

LIFETIME DIAGNOSIS FOR FANS

Enter the Pr.87 (Fan exchange warning level) code (%). After the selected usage (%) is reached (out of 50,000 hours), the fan exchange warning message will appear in the multi-functional output or keypad.

The total fan usage level (%) appears at Pr.86. When exchanging fans, you may initialize the accumulated value to 0 by setting the Pr.88 (Initializing accumulated time for cooling fans) to 1.

Pr. Group	Pr. Code	Name	Parameter Setting	Setting range	Unit
Pr	Pr.86	Accumulated percent of fan usage	0.0	0.0–6553.5	%
	Pr.87	Fan exchange warning Level	90.0	0.0–100.0	%
OU	OU.31	Multi-function Relay1	37	FAN Exchange	–
	OU.33	Multi-function Relay2			

LOW VOLTAGE FAULT TRIP

When drive input power is lost and the internal DC link voltage drops below a certain voltage level, the drive stops output and a low voltage trip occurs.

Pr. Group	Pr. Code	Name	Parameter Setting		Setting range	Unit
Pr	Pr.81	Low voltage trip decision delay time	0.0		0–60	sec
OU	OU.31	Multi-function Relay1	11	Low Voltage	–	–
	OU.33	Multi-function Relay2				

Low Voltage Fault Trip Setting Details

Pr. Code	Description
Pr.81 LVT Delay	If the OU.31 code value is set to 11 (Low Voltage), the drive stops the output first when a low voltage trip condition arises, then a fault trip occurs after the low voltage trip decision time is passed. The warning signal for a low voltage fault trip can be provided using the multi-function relay. However, the low voltage trip delay time (LVT Delay time) does not apply to warning signals.

OUTPUT BLOCK BY MULTI-FUNCTION TERMINAL

When the multi-function input terminal is set as the output block signal terminal and the signal is input to the terminal, then the operation stops.

Pr. Group	Pr. Code	Name	Parameter Setting		Setting range	Unit
In	In.65–In.69	Px terminal setting options	5	BX	0–52	–

Output Block by Multi-Function Terminal Setting Details

Pr. Code	Description
In.65–In.69 Px Define	When the operation of the multi-function input terminal is set to 5 (BX) and is turned on during operation, the drive blocks the output and 'BX' is displayed on the keypad display. While 'BX' is displayed on the keypad screen, the drive's operation information including the operation frequency and current at the time of BX signal can be monitored. The drive resumes operation when the BX terminal turns off and operation command is input.

TRIP STATUS RESET

Restart the drive using the keypad or analog input terminal, to reset the trip status.

Pr. Group	Pr. Code	Name	Parameter Setting		Setting range	Unit
In	In.65–In.69	Px terminal setting options	3	RST	0–52	–

Trip Status Reset Setting Details

Pr. Code	Description
In.65–In.69 Px Define	Press [Stop/Reset] key on the keypad or use the multi-function input terminal to restart the drive. Set the multi-function input terminal to 3 (RST) and turn on the terminal to reset the trip status.

DRIVE DIAGNOSIS STATE

Check the diagnosis of components or devices for drive to check if they need to be replaced.

Pr. Group	Pr. Code	Name	Parameter Setting	Setting Range		Unit
Pr	Pr.89	FAN replacement warning	*	Bit	00–01	Bit
				00	–	
				01	FAN Warning	

**See "Bit Selection" on page 4–3 for details*

OPERATION MODE ON COMMUNICATION OPTION CARD TRIP

Option card (ACG-ET2) trips may occur when an option card is used with the drive. Set the operation mode for the drive when a communication error occurs between the option card and the drive body, or when the option card is detached during operation.

Pr. Group	Pr. Code	Name	Parameter Setting	Setting range	Unit	
Pr	Pr.80	Operation mode on Fieldbus (Ethernet) Communication option card trip	0	None	0–3	–
			1	Free-Run		
			2	Dec		

Operation Mode on Option Trip Setting Details

Pr. Code	Description		
Pr.80 Option Card (Comms) Trip Mode	Setting		Function
	0	None	No operation
	1	Free-Run	The drive output is blocked and fault trip information is shown on the keypad.
	2	Dec	The motor decelerates to the value set at Pr.7 (Trip Dec Time).

NO MOTOR TRIP

If an operation command is run when the motor is disconnected from the drive output terminal, a 'no motor trip' occurs and a protective operation is performed by the system.

Pr. Group	Pr. Code	Name	Parameter Setting	Setting range	Unit	
Pr	Pr.31	Operation on no motor trip	0	None	0–1	–
			1	Free-Run		
	Pr.32	No motor trip current level	5	1–100	%	
	Pr.33	No motor detection time	3.0	0.1–10	s	

No Motor Trip Setting Details

Pr. Code	Description
Pr.32 No Motor Level, Pr.33 No Motor Time	If the output current value [based on the rated current (bA.13)] is lower than the value set at Pr.32 (No Motor Level), and if this continues for the time set at Pr.33 (No Motor Time), a 'no motor trip' occurs.



CAUTION: If bA.7 (V/F PATTERN) IS SET TO 1 (SQUARE), SET PR.32 (NO MOTOR LEVEL) TO A VALUE LOWER THAN THE FACTORY DEFAULT. OTHERWISE, 'NO MOTOR TRIP' DUE TO A LACK OF OUTPUT CURRENT WILL RESULT WHEN THE 'NO MOTOR TRIP' OPERATION IS SET.

LOW VOLTAGE TRIP 2

If you set the Pr.82 (LV2 Selection) code to 1 (Yes), the trip notification is displayed when a low voltage trip occurs. In this case, even if the voltage of the DC Link bus is higher than the trip level, the LV2 trip will remain active. To reset the trip, reset the drive. The trip history will not be saved.

Pr. Group	Pr. Code	Name	Parameter Setting	Setting Range	Unit
Pr	Pr.82	LV2 Selection	1: Yes	0/1	–

DRIVE PRE-OVERHEAT WARNING

This feature outputs a warning if the drive temperature exceeds the temperature set by the user in Pr.77. The user can set up the operation for when the warning is generated before four types of overheating and output warning with the multi-function relay.

Pr. Group	Pr. Code	Name	Parameter Setting	Setting range	Unit	
Pr	Pr.77	Pre-overheat warning temperature	90	90–110	°C	
	Pr.78	Pre-overheat warning operation setting	0:None	0	None	–
				1	Warning	
				2	Free-Run	
			3	Dec		
OU	OU.31	Multi-function Relay1	41: Pre Over Heat	0–44	–	
	OU.33	Multi-function Relay2				

Pre-overheat Warning Operation Setting Details

Pr. Code	Description		
Pr.77 Pre-overheat warning temperature	Set the pre-overheat warning temperature. Setting Range: 90–110 °C.		
Pr.78 Pre-overheat warning operation setting	Setting	Function	
	0	None	No pre-overheat warning operation
	1	Warning	If the pre-overheat warning temperature is exceeded, warning message is displayed on the keypad and drive will operate normally.
	2	Free-Run	If the pre-overheat warning temperature is exceeded, a pre-overheat trip occurs and free-run will stop
	3	Dec	If the pre-overheat warning temperature is exceeded, a pre-overheat trip occurs and deceleration will stop.
OU.31, multi-function Relay1 OU.33, multi-function Relay2	Setting	Function	
	38	Pre-overheat warning	Signal is output if a pre-overheat warning or trip occurs.

TORQUE DETECTION PROTECTION ACTION

This feature outputs torque status to the multi-function relay if a motor overload or sudden underload occurs. This feature is activated when the multi-function relay (OU.31, OU.33) is set to 43, 44.

Pr. Group	Pr. Code	Name	Parameter Setting	Setting Range	Unit	
OU	OU.31	Multi-function Relay1	43	Prt Trq Det 1	0-44	-
	OU.33	Multi-function Relay2	44	Prt Trq Det 2	0-44	-
	OU.67*	Torque detection 1 operation setting	0	None	0-8	-
	OU.68*	Torque detection 1 level	100		0-200.0	%
	OU.69*	Torque detection 1 delay time	0.1		0.0-10.0	s
	OU.70**	Torque detection 2 operation setting	0	None	0-8	-
	OU.71**	Torque detection 2 level	100		0-200.0	%
	OU.72**	Torque detection 2 delay time	0.1		0.0-10.0	s

* Visible only when the multi-function relay (OU.31, 33) is set to 43 (Prt Trq Det 1).

**Visible only when the multi-function relay (OU.31, 33) is set to 44 (Prt Trq Det 2).

The over and under torque detection action operates as shown in the figure by having a hysteresis level of 10% compared to the motor's rated current.

Over Torque Detection Action

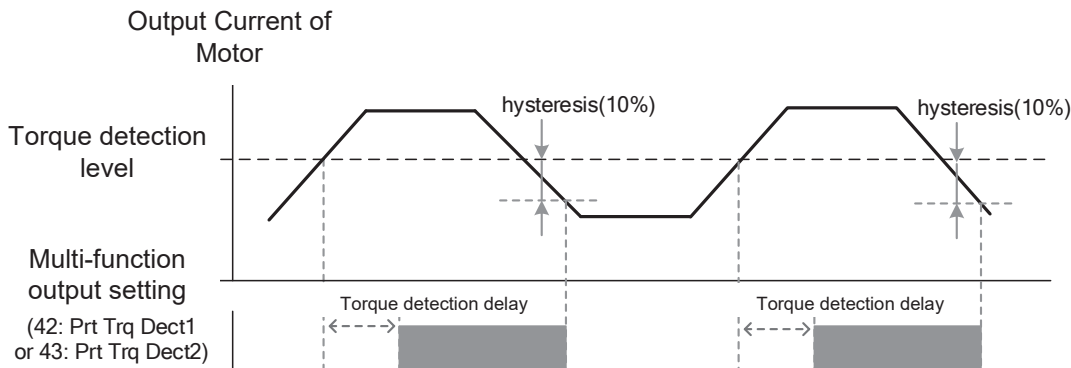

Under Torque Detection Action

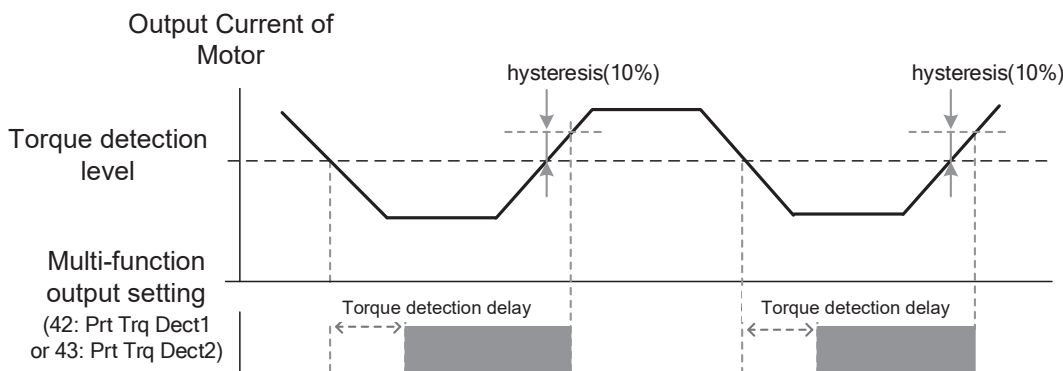

The over and under torque detection level set as OU68, 71 parameters are set as the ratio on motor's rated current.

Torque Detection Operation Setting Details

Pr. Code	Description	
OU.67, Torque detection 1 operation setting OU.70, Torque detection 2 operation setting	Setting	Function
	0	None Torque detection is not operating.
	1	OT CmdSpd Warn Detects over torque and outputs warning only when the drive output frequency is the same as the command frequency.
	2	OT Warning Detects over torque during the operation and outputs warning.
	3	OT CmdSpdTrip Detects over torque and generates a trip only when the drive output frequency is the same as the command frequency.
	4	OT Trip Detects over torque during operation and generates a trip.
	5	UT CmdSpd Warn Detects under torque and outputs warning only when the drive output frequency is the same as the command frequency.
	6	OT Warning Detects under torque during the operation and outputs warning.
	7	UT CmdSpd Trip Detects under torque and generates a trip only when the drive output frequency is the same as the command frequency.
8	UT Trip Detects under torque during operation and generates a trip.	
OU.68, Torque detection 1 level OU.71, Torque detection 2 level	Sets the torque detection level of torque detection 1, 2. The set value is a % of the motor's rated current. The detection level must be higher than bA.14 no load current value.	
OU.69, Torque detection 1 delay time OU.72, Torque detection 2 delay time	Sets the delay time on torque detection 1, 2. When over or under torque is detected, a warning or trip is output after the torque detection delay time.	

FAULT/WARNING LIST

The following list shows the types of faults and warnings that can occur while using the ACG drive. For specific fault codes, details, and troubleshooting steps, refer to page 6–7. Explanation of user controlled faults and warnings can be found in "Learning Protection Features" on page 4–138.

Category		Details
Major fault	Latch type	Over current trip
		Over voltage trip
		Trip due to an external signal
		Temperature sensor fault trip
		ARM short current fault trip
		Option (communication card) fault trip*
		Over heat fault trip
		Output open–phase fault trip
		Input open–phase fault trip
		Drive overload fault trip
		Ground fault trip**
		Fan fault trip
		Motor overheat fault trip
		Pre–PID operation failure
		IO Board connection fault trip
		External brake fault trip
		No motor fault trip
		Low voltage fault trip during operation
		Drive pre-overheat trip
		Over torque 1 trip
	Under torque 1 trip	
	Over torque 2 trip	
	Under torque 2 trip	
Level type	Low voltage fault trip	
	Emergency stop fault trip	
	Command loss trip	
Hardware damage	External memory error	
	Analog input error	
	CPU Watch Dog fault trip	
Minor fault	Motor overload fault trip	
	Motor underload fault trip	

* Applies only when a communication card (ACG-ET2) is used.
 **Ground detection feature is provided only in 230V/460V 7.5–30 hp products. Other products protect drive with OVT/OCT/OC2 trip when grounding occurs.

Category	Details
Warning	Command loss fault trip warning
	Overload warning
	Under load warning
	Drive overload warning
	Fan operation warning
	Braking resistor braking rate warning
	Rotor time constant tuning error
	Fan replacement warning
	Drive pre-overheat warning
	Over torque 1 warning
	Under torque 1 warning
	Over torque 2 warning
	Under torque 2 warning
<p>* Applies only when a communication card (ACG-ET2) is used.</p> <p>**Ground detection feature is provided only in 230V/460V 7.5–30 hp products. Other products protect drive with OVT/OCT/OC2 trip when grounding occurs.</p>	