

CHAPTER 2: INSTALLATION AND WIRING



TABLE OF CONTENTS

Chapter 2: Installation and Wiring

Drive Models by Frame Size 2-3

Installation 2-3

Basic Configuration Diagram 2-3

Installation Considerations 2-4

Minimum Clearances and Air Flow 2-4

Dimensions 2-6

Mounting the Drive 2-7

Removing Front Cover 2-9

Cable Wiring 2-10

Floating Ground System 2-11

Cable Selection 2-12

Ground Cable and Power Cable Specifications 2-12

Control (signal) Cable Specifications 2-13

Ground Connection 2-13

Power Terminal Wiring 2-14

0.5 – 1 HP (3-phase) 2-14

2.0 – 3.0 HP (3-phase) 2-14

5 HP (3-phase) 2-15

7.5 – 10 HP (3-phase) 2-15

15 – 30 HP (3-phase) 2-16

Main Circuit Wiring Diagram (all frames) 2-17

Power Terminal Labels and Descriptions 2-17

Terminals for Connecting DC Reactor, External Brake Resistor, and DC Circuit 2-18

Wiring Guidelines 2-19

Motor Operation Precautions 2-19

Single Phase Input Utility Wiring and Operation 2-20

Power (HP), Input Current and Output Current 2-21

Input Frequency and Voltage Tolerance 2-21

Protection 2-21

Control Terminal Wiring 2-22

Control Board Switches 2-22

Connector 2-22

Full I/O Wiring Diagram 2-23

Input Terminal Labels and Descriptions 2-24

Output/Communication Terminal Labels and Descriptions 2-24

Pre-insulated Crimp Terminal Connectors (Bootlace Ferrule) 2-25

PNP/NPN Mode Wiring and Selection 2-26

PNP Mode (Source) 2-26

NPN Mode (Sink) 2-26

Run Command Wiring. 2-27

Relay Output Wiring. 2-27

Analog Wiring 2-28

AO Wiring 2-29

System Wiring Diagram. 2-29

Re-assembling the Cover. 2-30

Post-Installation Checklist. 2-31

Test Run 2-32

Verifying the Motor Rotation. 2-33

DRIVE MODELS BY FRAME SIZE

ACG Series Drive Models by Frame Size	
Frame	Drive
A	ACG-20P5, ACG-21P0, ACG-40P5, ACG-41P0
B	ACG-22P0, ACG-23P0, ACG-42P0, ACG-43P0
C	ACG-25P0, ACG-45P0
D	ACG-27P5, ACG-2010, ACG-47P5, ACG-4010
E	ACG-2015, ACG-2020, ACG-4015, ACG-4020
F	ACG-4025, ACG-4030

INSTALLATION

Install the AC drive in a properly sized panel. Provide proper spacing to allow the dissipation of heat produced by the drive and any other installed electrical and electronic equipment. Ventilation or air conditioning may also be required, depending upon the application.



FAILURE TO OBSERVE THESE PRECAUTIONS MAY DAMAGE THE DRIVE AND VOID THE WARRANTY. IMPROPER INSTALLATION OF THE AC DRIVE WILL GREATLY REDUCE ITS LIFE. OBSERVE THE FOLLOWING PRECAUTIONS WHEN INSTALLING THE DRIVE:

- Do not mount the AC drive near heat-radiating elements or in direct sunlight.
- Do not install the AC drive in a place subjected to high temperature, high humidity, excessive vibration, corrosive gases or liquids, or airborne dust or metallic particles.
- Mount the AC drive securely on a flat, rigid, non-flammable surface.
- Mount the AC drive vertically and do not restrict the air flow to the heat sink fins.
- Prevent fiber particles, scraps of paper, shredded wood saw dust, metal particles, etc., from adhering to the heat sink.
- Install covers and circuit breakers before operating the drive. Drawings in this manual are shown with covers or circuit breakers removed to show a more detailed view of the installation arrangements.
- Operate the product according to the instructions in this manual.

BASIC CONFIGURATION DIAGRAM

The reference diagram below shows a typical system configuration showing the drive and peripheral devices.

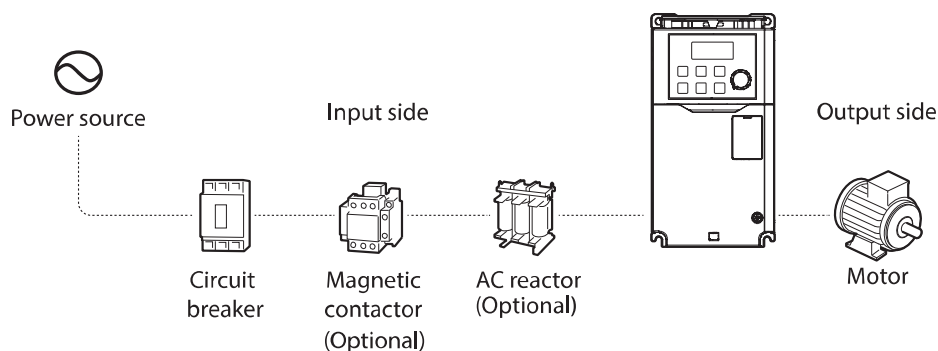

INSTALLATION CONSIDERATIONS

Drives are composed of various precision, electronic devices, and therefore the installation environment can significantly impact the lifespan and reliability of the product. See the environmental conditions table in Chapter 1 for information on the ideal operation and installation conditions for the drive.

MINIMUM CLEARANCES AND AIR FLOW

When selecting an installation location, consider the following points:

- The location must be free from vibration, and the drive must be installed on a wall that can support the drive's weight
- The drive can become very hot during operation. Install the drive on a surface that is fire-resistant or flame-retardant and with sufficient clearance around the drive to allow air to circulate.

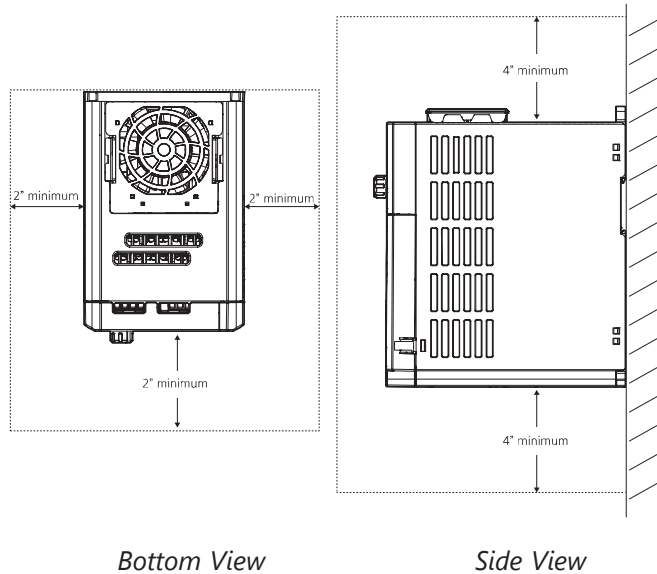

Ensure sufficient air circulation is provided around the drive when it is installed. If the drive is to be installed inside a panel, enclosure, or cabinet rack, carefully consider the position of the drive's cooling fan and the ventilation louver. Cooling fans must be positioned to efficiently transfer the heat generated by the operation of the drive.

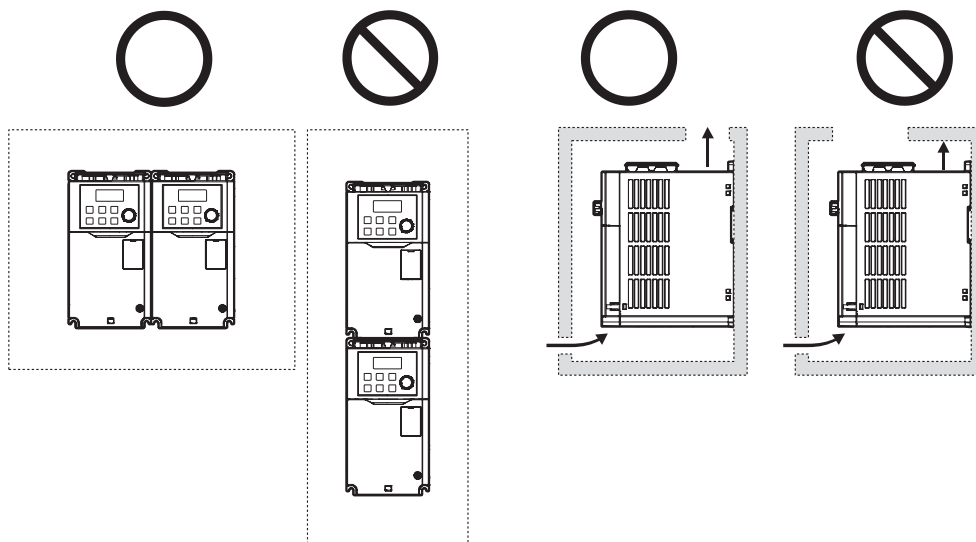

If you are installing multiple drives in one location, arrange them side-by-side and remove the top covers. The top covers MUST be removed for side-by-side installations. Use a flat-head screwdriver to remove the top covers.

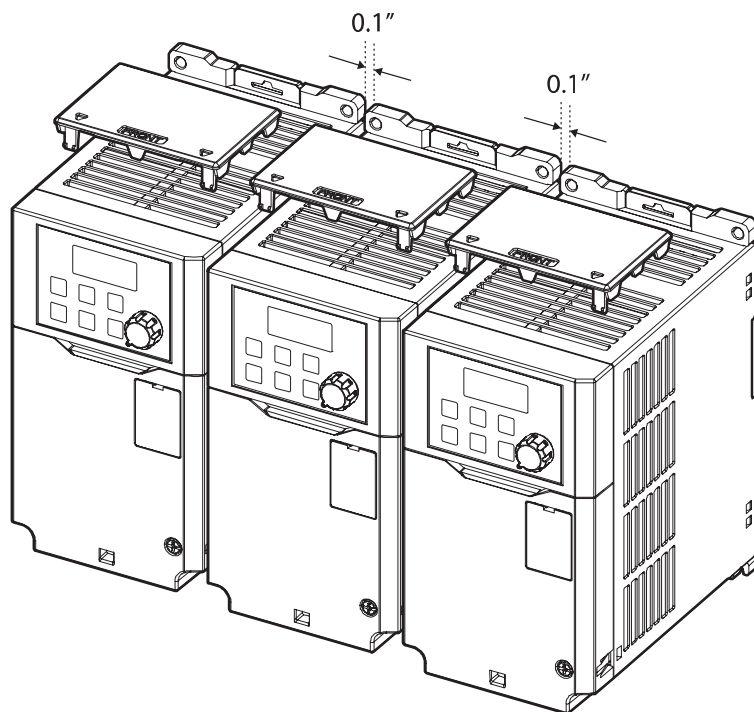

If you are installing multiple drives of different ratings, provide sufficient clearance to meet the clearance specifications of the larger drive.

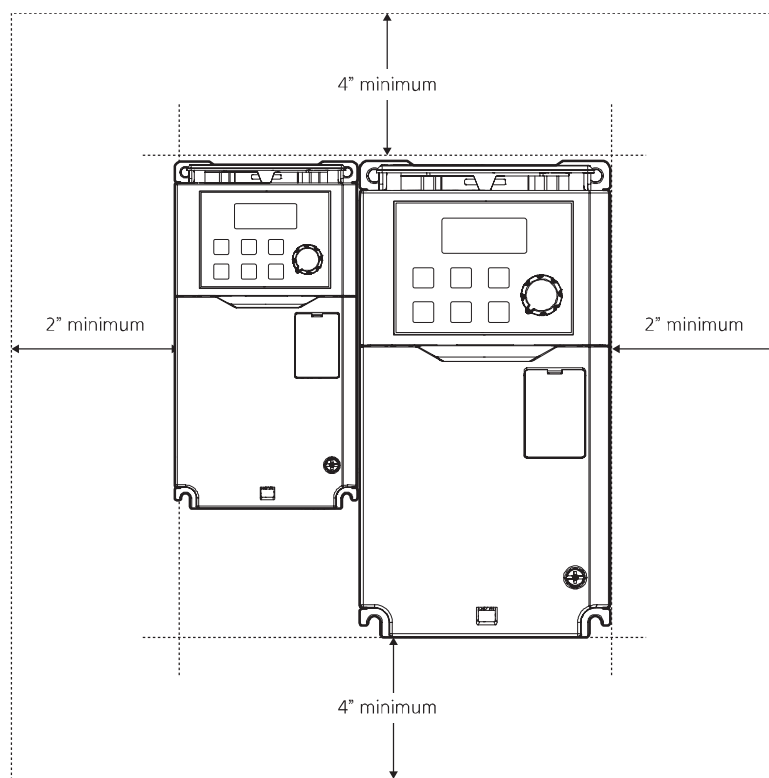

DIMENSIONS

See our website: www.AutomationDirect.com for complete engineering drawings and 3D models.

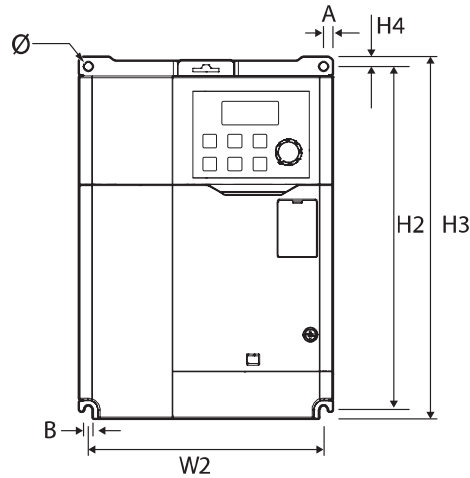
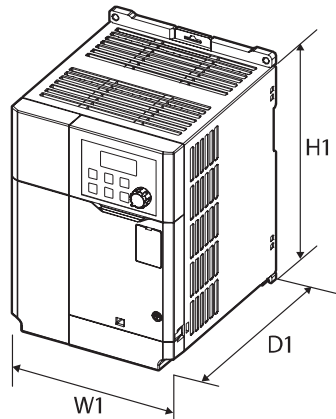

Dimensions												
Frame	Part no	W1	W2	H1	H2	H3	H4	D1	A	B	Ø	Drawings
A	ACG-20P5	86.2 (3.39)	76.2 (3.00)	154 (6.06)	154 (6.06)	164 (6.46)	5 (0.20)	131.5 (5.18)	5 (0.2)	4.5 (0.18)	4.5 (0.18)	PDF
	ACG-21P0											PDF
	ACG-40P5											PDF
	ACG-41P0											PDF
B	ACG-22P0	101 (3.98)	90 (3.54)	167 (6.57)	167 (6.57)	177 (6.97)	5 (0.2)	150.5 (5.93)	5.5 (0.22)	4.5 (0.18)	4.5 (0.18)	PDF
	ACG-23P0											PDF
	ACG-42P0											PDF
	ACG-43P0											PDF
C	ACG-25P0	135 (5.31)	125 (4.92)	183 (7.2)	183 (7.2)	193 (7.6)	5 (0.2)	150.5 (5.93)	5 (0.2)	4.5 (0.18)	4.5 (0.18)	PDF
	ACG-45P0											PDF
D	ACG-27P5	180 (7.09)	Top: 162 (6.38) Bottom: 170 (6.70)	220 (8.66)	229.5 (9.04)	240 (9.45)	5.5 (0.22)	144 (5.67)	Top: 9 (0.35) Bottom: 5 (0.20)	4.5 (0.18)	Φ-1: 4.5 (0.18) Φ-2: 9 (0.35)	PDF
	ACG-2010											PDF
	ACG-47P5											PDF
	ACG-4010											PDF
E	ACG-2015	180 (7.09)	157 (6.18)	290 (11.4)	273.7 (10.8)	290 (11.4)	11.3 (0.44)	173 (6.81)	8.5 (0.33)	4.5 (0.18)	Φ-1 : 4.5(0.18) Φ-2 : 8.5(0.33)	PDF
	ACG-2020											PDF
	ACG-4015											PDF
	ACG-4020											PDF
F	ACG-4025	220 (8.66)	193.8 (7.63)	345 (13.6)	331 (13)	345 (13.6)	8 (0.31)	187 (7.36)	10.1 (0.4)	5.5 (0.22)	Φ-1: 5.5 (0.22) Φ-2: 1 (0.43)	PDF
	ACG-4030											PDF

Units: mm (in)

MOUNTING THE DRIVE

Mount the drive on a wall or inside a panel following the procedures below. Before installation, ensure that there is sufficient space to meet the clearance specifications, and that there are no obstacles impeding the cooling fan's air flow. The drive must be installed on a wall that can support the drive's weight. The location must be free from vibration, which can adversely affect the operation of the drive.

Select a wall or panel suitable to support the installation. Refer to the dimensions drawings and check the drive's mounting bracket dimensions.

- Use a level to draw a horizontal line on the mounting surface, and then carefully mark the fixing points.
- Drill the two upper mounting bolt holes, and then install the mounting bolts into the top holes of the drive. Do not fully tighten the bolts at this time. Fully tighten the mounting bolts after the drive has been mounted.

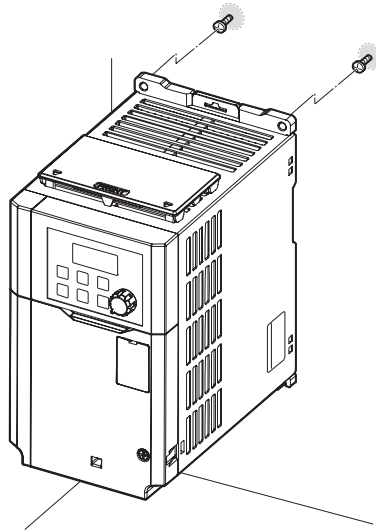

- Mount the drive on the wall or inside a panel using the two lower bolts, and then fully tighten the mounting bolts. Ensure that the drive is placed flat on the mounting surface, and that the installation surface can securely support the weight of the drive.

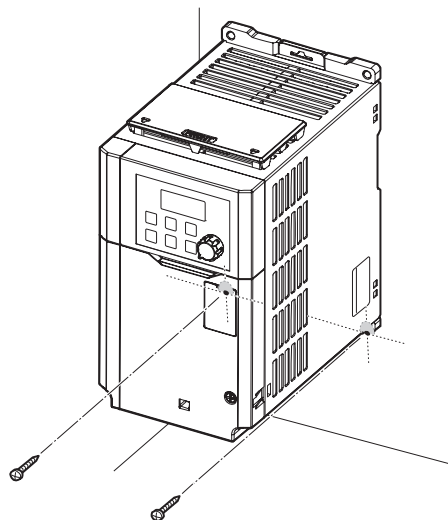



CAUTION: FAILURE TO OBSERVE THESE PRECAUTIONS MAY DAMAGE THE DRIVE OR CAUSE INJURY.

- Caution: Do not transport the drive by lifting with the drive's covers or plastic surfaces. The drive may tip over if covers break, causing injuries or damage to the product. Always support the drive using the metal frames when moving it.
- Hi-capacity drives are very heavy and bulky. Use an appropriate transport method that is suitable for the weight.
- Do not install the drive on the floor or mount it sideways against a wall. The drive MUST be installed vertically, on a wall or inside a panel, with its rear face flat against the mounting surface.

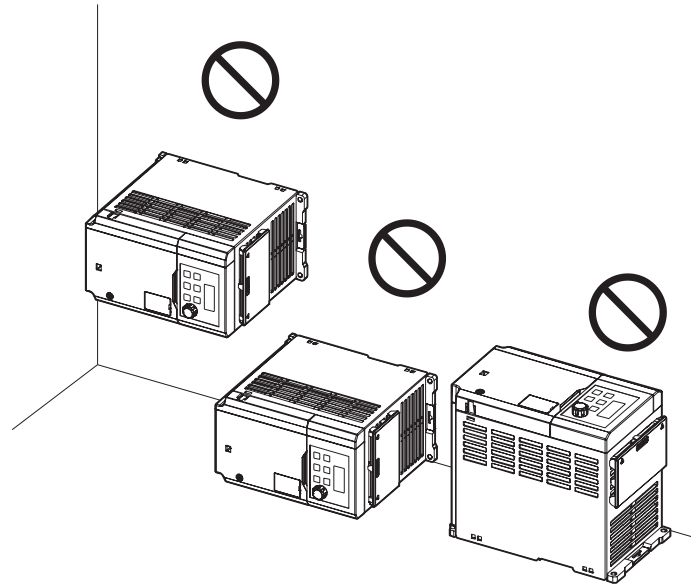

REMOVING FRONT COVER

The front cover must be removed to install cables. The procedure to do so varies slightly depending on your drive model.

1/2 TO 10 HP DRIVES

Loosen the bolt that secures the front cover. Push and hold the latch on the right side of the cover, then remove the cover by lifting it from the bottom and moving it away from the front of the drive.

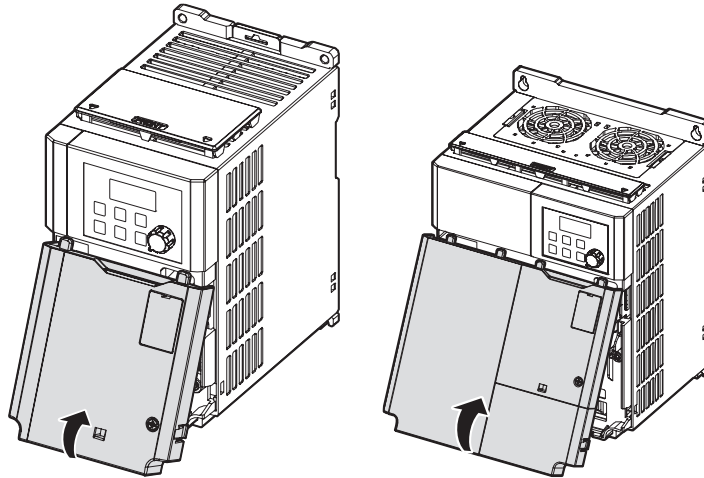

15 TO 30 HP DRIVES

Loosen the bolt that secures the front cover, and then pull the cover outward to remove it. Then, loosen the hook (or bolt) that secures the cable rack and pull the rack outward to remove it.

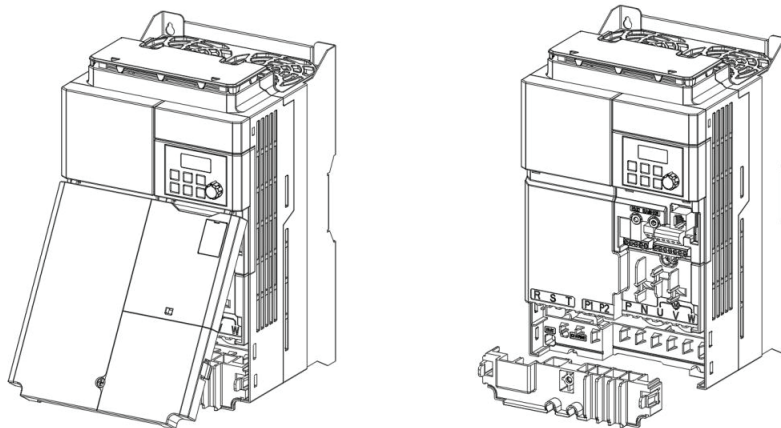

NOTE: To connect a remote keypad, remove the plastic knock-out from the bottom of the front cover (right side) or from the control terminal cover. Then connect the signal cable to the RJ-45 port on the control board.

CABLE WIRING

Open the front cover, remove the cable guides and control terminal cover, and then install the ground connection as specified. Complete the cable connections by connecting an appropriately rated cable to the terminals on the power and control terminal blocks.



READ THE FOLLOWING INFORMATION CAREFULLY BEFORE MAKING ANY WIRING CONNECTIONS TO THE DRIVE.

- Install the drive before making any wiring connections.
- Ensure that no small metal debris, such as wire cut-offs, remain inside the drive. Metal debris in the drive may cause drive failure.
- Tighten terminal screws to their specified torque. Loose terminal block screws may allow the cables to disconnect and cause short circuit or drive failure.
- Do not place heavy objects on top of electric cables. Heavy objects may damage the cable and result in electric shock.
- The power supply system for the ACG drive is a grounded system. Only use a grounded power supply system for the ACG drive. Do not use a TT, TN, IT, or corner grounded system with the drive.
- The equipment may generate direct current in the protective ground wire. When installing the residual current device (RCD) or residual current monitoring (RCM), only Type B RCDs and RCMs can be used.
- Use cables with the largest cross-sectional area, appropriate for power terminal wiring, to ensure that voltage drop does not exceed 2%.
- Use copper cables rated at 600V, 75° for power terminal wiring.
- Use copper cables rated at 300V, 75° for control terminal wiring.
- Separate control circuit wires from the main circuits and other high voltage circuits (230V relay sequence circuit).
- Check for short circuits or wiring failure in the control circuit. They could cause system failure or device malfunction.
- Use shielded cables when wiring the control circuit. Failure to do so may cause malfunction due to interference. If a ground is needed, use STP (Shielded Twisted Pair) cables.
- If you need to re-wire the terminals due to wiring-related faults, ensure that the drive keypad display is turned off and the charge lamp under the front cover is off before working on wiring connections. The drive may hold a high voltage electric charge long after the power supply has been turned off.

FLOATING GROUND SYSTEM

The power supply system for this drive is an ungrounded system. The drive does not contain an input EMC filter. Therefore, an Asymmetric/Corner grounded power system can be safely used with the drive.

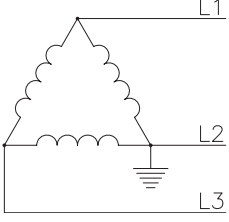
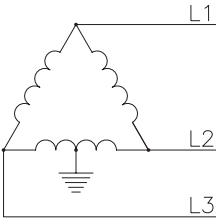
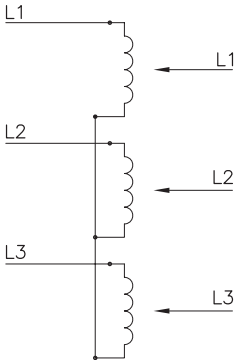
Asymmetric Ground / Corner Grounded TN Systems	
<p>1) Grounding at a Corner of a Triangle Configuration</p> 	<p>2) Grounding at a Midpoint in a Polygonal Configuration</p> 
<p>3) No Stable Neutral Grounding in a Three-Phase Autotransformer Configuration</p> 	

CABLE SELECTION

When you install power and signal cables in the terminal blocks, only use cables that meet the required specification for the safe and reliable operation of the product. Refer to the following information to assist you with cable selection.



READ THE FOLLOWING INFORMATION CAREFULLY BEFORE MAKING ANY WIRING CONNECTIONS TO THE DRIVE.

- Wherever possible use cables with the largest cross-sectional area for mains power wiring to ensure that voltage drop does not exceed 2%.
- Use copper cables rated for 600V, 75° for power terminal wiring.
- Use copper cables rated for 300V, 75° for control terminal wiring.
- Utilize shielded VFD cable or Output line reactors/dVdT filters for any motor cable length over 100 feet.
- Ensure that the total cable length does not exceed 665ft (202m). For drives ≤ 5 HP capacity, ensure that the total cable length does not exceed 165ft (50m).

GROUND CABLE AND POWER CABLE SPECIFICATIONS

Ground Cable and Power Cable Specifications					
Load (hp)		Ground		Power I/O R/S/T & U/V/W	
		mm ²	AWG	mm ²	AWG
3-Phase 230V	0.5	4	12	2.5	14
	1				
	2				
	3				
	5	6	10	4	12
	7.5			6	10
	10			10	8
	15			16	6
	20			25	4
3-Phase 460V	0.5	2.5	14	2.5	14
	1				
	2				
	3				
	5				
	7.5	4	12	4/2.5	12/14
	10			4	12
	15			6	10
	20	10	8	16/10	6/8
	25				
	30				

CONTROL (SIGNAL) CABLE SPECIFICATIONS

Control (signal) Cable Specifications				
Terminals	Signal Cable			
	Without Crimp Terminal Connectors (Bare wire)		With Crimp Terminal Connectors (Bootlace Ferrule)	
	mm ²	AWG	mm ²	AWG
24/P1, P1-P5, CM	0.8	18	0.5	20
A1/B1/C1/A2/C3/VR/V1 I2/AO/CM/Q1/EG/S+/S-	0.8	18	0.5	20

GROUND CONNECTION

Remove the front cover(s), cable guide, and the control terminal cover. Locate the ground terminal and connect an appropriately rated ground cable to the terminals.

Connect the other ends of the ground cable to the supply earth (ground) terminal.

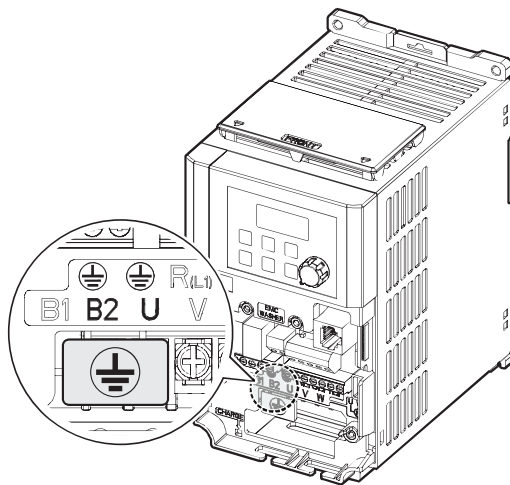

0.5 – 10 hp Drives

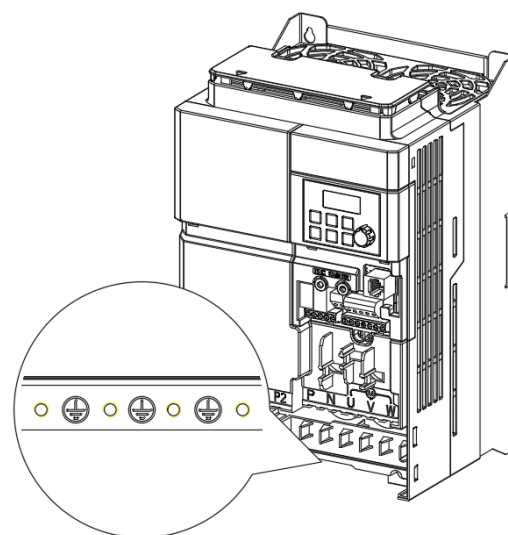

15 – 30 hp Drives



NOTE: 230V products require Class 3 grounding. Resistance to ground must be < 100Ω. 460V products require Special Class 3 grounding. Resistance to ground must be < 10Ω.



WARNING: INSTALL GROUND CONNECTIONS FOR THE DRIVE AND THE MOTOR BY FOLLOWING THE CORRECT SPECIFICATIONS TO ENSURE SAFE AND ACCURATE OPERATION. USING THE DRIVE AND THE MOTOR WITHOUT THE SPECIFIED GROUNDING CONNECTIONS MAY RESULT IN ELECTRIC SHOCK.

POWER TERMINAL WIRING

The following drawings show the terminal layouts on the power terminal blocks. Refer to them to understand the function and location of each terminal before making wiring connections. Ensure that the cables selected meet or exceed the specifications in the cable selection table before installing them.



READ THE FOLLOWING INFORMATION CAREFULLY BEFORE MAKING ANY WIRING CONNECTIONS TO THE DRIVE.

- Apply rated torques to the terminal screws. Loose screws may cause short circuits and malfunctions. Tightening the screw too much may damage the terminals and cause short circuits and malfunctions.
- Use copper wires only with 600V, 75°C rating for the power terminal wiring, and 300V, 75°C rating for the control terminal wiring.
- Do not connect two wires to one terminal when wiring the power.
- Power supply wirings must be connected to the R, S, and T terminals. Connecting them to the U, V, W terminals causes internal damage to the drive. Motor should be connected to the U, V, and W Terminals. Arrangement of the phase sequence is not necessary.

0.5 – 1 HP (3-PHASE)

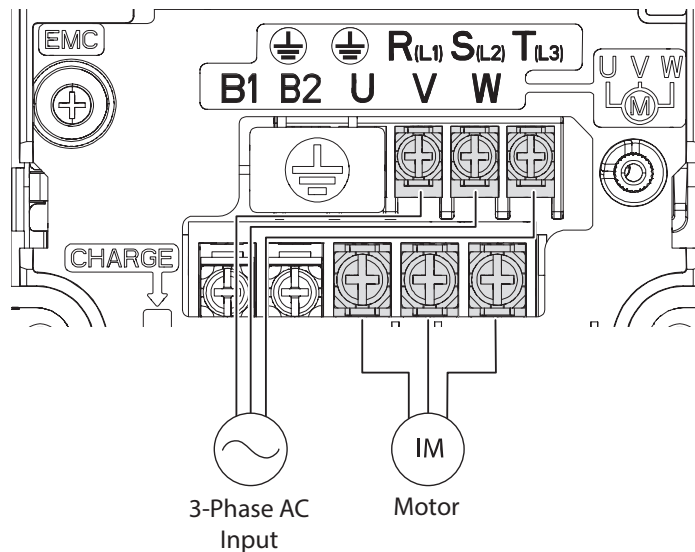

2.0 – 3.0 HP (3-PHASE)

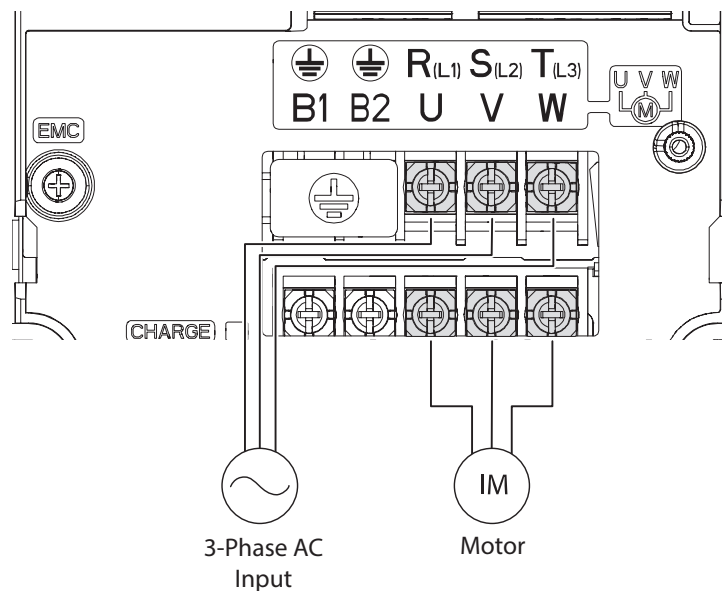

5 HP (3-PHASE)

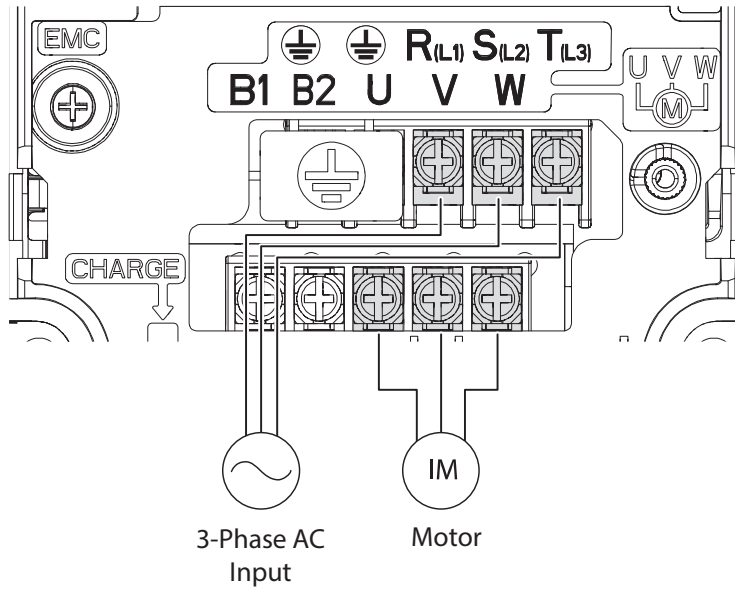

7.5 – 10 HP (3-PHASE)

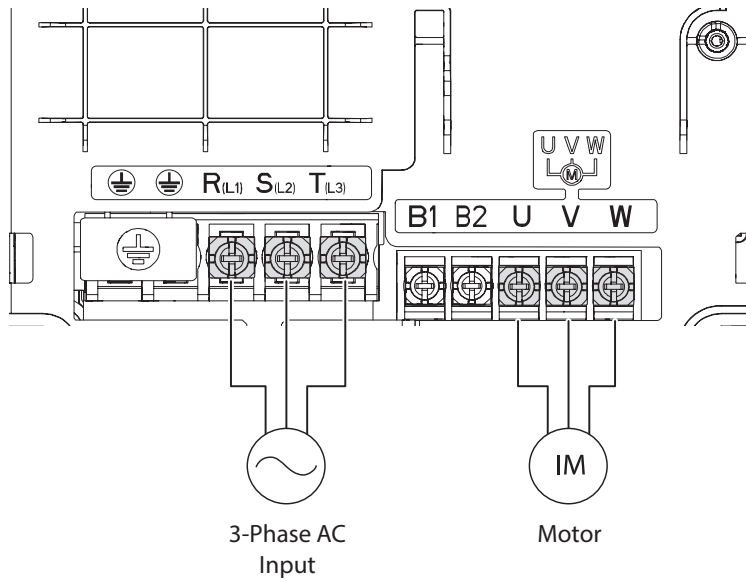

15 – 30 HP (3-PHASE)

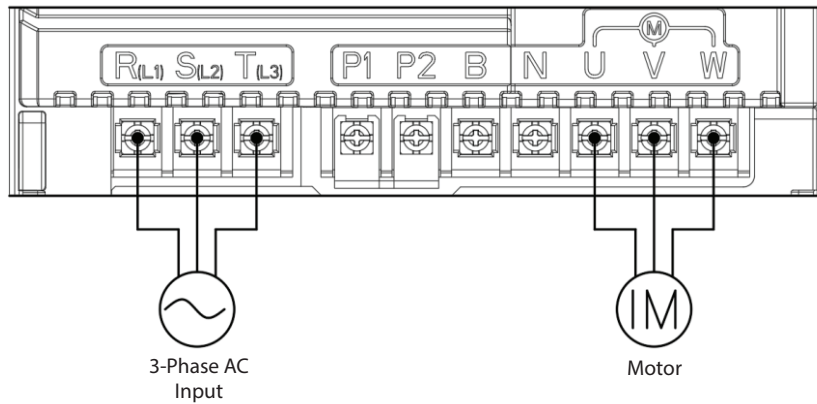

MAIN CIRCUIT WIRING DIAGRAM (ALL FRAMES)

0.5 to 10 hp Drives

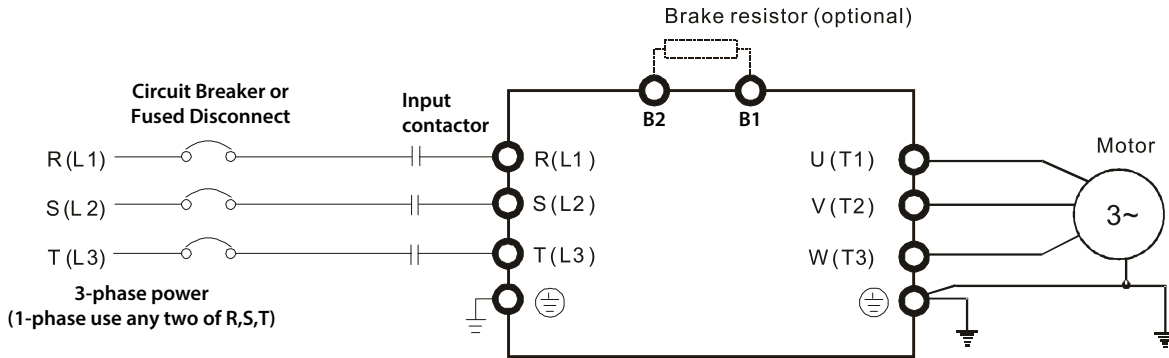

15 to 30 hp Drives

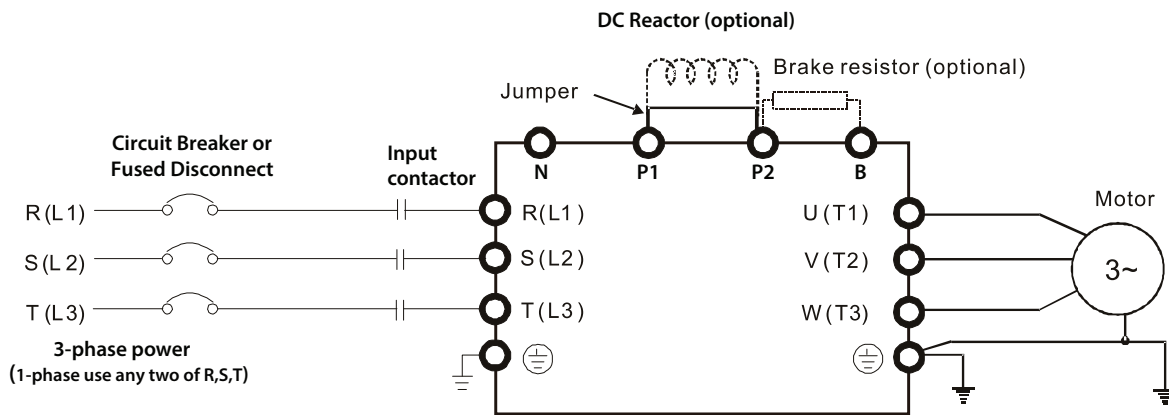

POWER TERMINAL LABELS AND DESCRIPTIONS

Power Terminal Labels and Descriptions		
Terminal Labels	Name	Description
R(L1)/S(L2)/T(L3)	AC power input terminal	Mains supply AC power connections (<i>For single phase input, any two of the R,S,T terminals may be used</i>)
P2(+)/N(-)	DC input terminal	DC voltage terminals for 15–30 hp drives only.
P1(+)/P2(+)	DC reactor terminal	DC reactor wiring connection for 15-30 hp drives. (Remove the short-bar when you use the DC reactor)
B1/B2 (0.5 to 10 hp) P2(+)/B (15 to 30 hp)	Brake resistor terminals	Brake resistor wiring connection
U/V/W	Motor output terminals	3-phase AC motor wiring connections

TERMINALS FOR CONNECTING DC REACTOR, EXTERNAL BRAKE RESISTOR, AND DC CIRCUIT

- Terminals P1 and P2 are used to connect an optional DC reactor or choke to improve power factor. From the factory, these terminals are connected with a short-circuit jumper. Remove this jumper before connecting a DC reactor.
- Tighten the jumper if a DC reactor is not connected and P2 & B or P1 & N terminals are used for common DC bus or brake resistors. This will prevent the AC motor drive from losing power and damage to the terminals. If the jumper is missing due to wiring, refer to the recommended main circuit terminal wire to short-circuit the P1 and P2 terminals.
- Install an external brake resistor for applications in frequent deceleration to stop, short deceleration time (such as high frequency operation and heavy load operation), too low braking torque, or increased braking torque.
- For ACG series drives, the external brake resistor should be connected to the B1 and B2 terminals for 1/2 to 10 hp drives, and the B1 and P2 terminals for 15 to 30 hp drives. See appendix accessories for recommended braking resistor sizes.
- P2 and N are connected for common DC bus for 15 to 30 hp drives.
- Please refer to the DURApulse Drives Dynamic Braking User Manual for more information on ADC braking resistors. (Available for free download at <http://www.automationdirect.com/static/manuals/index.html>.)

WIRING GUIDELINES

- Do not use 3 core cables to connect a remotely located motor with the drive.
- When operating brake resistor, the motor may vibrate under the Flux braking operation. In this case, please turn off the Flux braking (Pr.50).
- Ensure that the total cable length does not exceed 665ft (202m). For drives < = 5 HP capacity, ensure that the total cable length does not exceed 165ft (50m).
- Long cable runs can cause reduced motor torque in low frequency applications due to voltage drop. Long cable runs also increase a circuit's susceptibility to stray capacitance and may trigger over-current protection devices or result in malfunction of equipment connected to the drive.
- Voltage drop is calculated by using the following formula:
Voltage Drop (V) = $[\sqrt{3} \times \text{cable resistance (m}\Omega/\text{m)} \times \text{cable length (m)} \times \text{current(A)}] / 1000$
- Use cables with the largest possible cross-sectional area to ensure that voltage drop is minimized over long cable runs. Lowering the carrier frequency and installing a micro surge filter may also help to reduce voltage drop.

Distance	<165ft (50m)	<330ft (100m)	>330ft (100m)
Allowed Carrier Frequency	<15 kHz	<5kHz	<2.5kHz



WARNING: DO NOT CONNECT POWER TO THE DRIVE UNTIL INSTALLATION HAS BEEN FULLY COMPLETED AND THE DRIVE IS READY TO BE OPERATED. DOING SO MAY RESULT IN ELECTRIC SHOCK.



READ THE FOLLOWING INFORMATION CAREFULLY BEFORE MAKING ANY WIRING CONNECTIONS TO THE DRIVE.

- Power supply cables must be connected to the R, S, and T terminals and output wiring to the motor must be connected to the U, V, and W terminals. Connecting power cables to other terminals will damage the drive.
- Use insulated ring lugs when connecting cables to R/S/T and U/V/W terminals.
- The drive's power terminal connections can cause harmonics that may interfere with other communication devices located near to the drive. To reduce interference the installation of noise filters or line filters may be required.
- Verify any advanced-phase capacitors, surge protection, or electromagnetic interference filters are installed correctly before powering on the drive.
- To avoid circuit interruption or damaging connected equipment, do not install phase-advanced condensers, surge protection, magnetic contactors or electronic noise filters on the output side of the drive.

MOTOR OPERATION PRECAUTIONS

- Avoid running a standard induction motor at low speed, which may cause the motor temperature to exceed the motor rating due to limited airflow produced by the motor's fan.
- When the standard motor operates at low speed, the output load must be decreased.
- If 100% output torque is desired at low speed, use AC motors in the High performance drive duty category at automationdirect.com.

SINGLE PHASE INPUT UTILITY WIRING AND OPERATION

Ironhorse ACG is a three-phase standard variable frequency drive (VFD). When applying single-phase power to a three-phase VFD, there are several constraints that need to be considered. Standard Pulse-Width-Modulated (PWM) VFDs use a 6-pulse diode rectifier. The 6-pulse rectification results in 360 Hz DC bus ripple when used with a three-phase 60 Hz supply.

However, under single-phase use, the DC bus ripple becomes 120 Hz and the VFDs DC bus circuit is subject to higher stress in order to deliver equivalent power.

Additionally, input currents and harmonics increase beyond those encountered with three phase input. Input current distortion of 90% THD and greater can be expected under single-phase input, compared to approximately 40% with three-phase input as indicated in Figure 2. Therefore, single-phase use requires the three-phase VFD power rating be reduced (derated) to avoid over stressing the rectifier and DC link components.

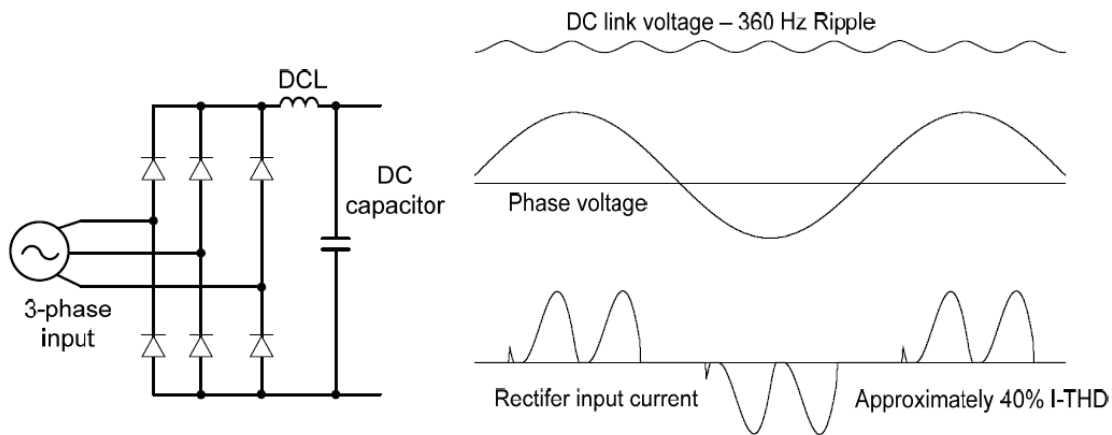

Figure-1 Typical Three-Phase Configuration

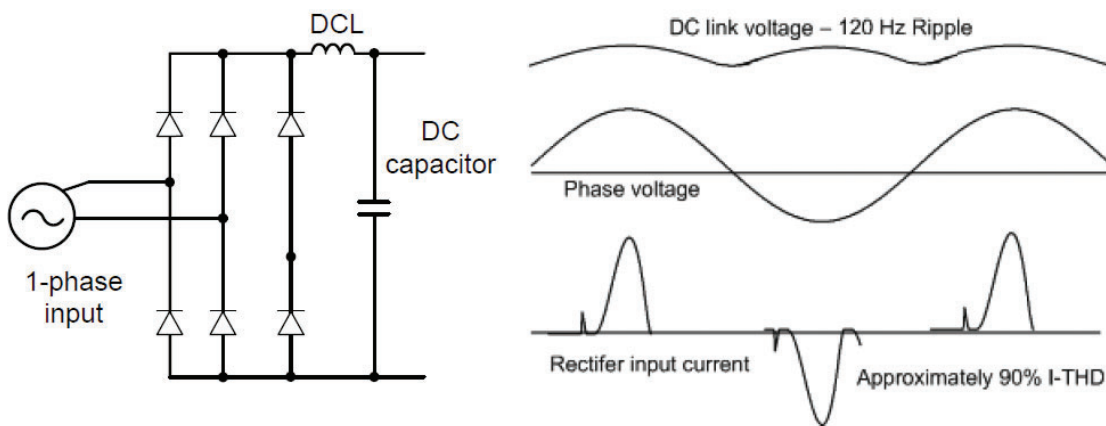

Figure-2 Typical Single-Phase Configuration

POWER (HP), INPUT CURRENT AND OUTPUT CURRENT

When using a three-phase VFD with single-phase input, derating the drive's output current and horsepower will be necessary because of the increase in DC bus ripple voltage and current. In addition, the input current through the remaining two phases on the diode bridge converter will approximately double, creating another derating consideration for the VFD. Input current harmonic distortion will increase beyond that with a three-phase supply making the overall input power factor low. Input current distortion over 100% is likely under single-phase conditions without a reactor. Therefore, it is required to install a line reactor on the drive input power. When using a motor that is selected by the three-phase drive rating criteria when using single phase input, it may result in poor performance, premature drive failure. The selected drive of single-phase current ratings must meet or exceed the motor current rating.



NOTE: For Single Phase Power input, an Input Line Reactor is required. See Accessories appendix for the specific line reactor for each drive model.

INPUT FREQUENCY AND VOLTAGE TOLERANCE

The single-phase current ratings are valid for 60Hz input only. The AC supply voltage must be within the required voltage range of 240/480Vac +10% to -5% to maximize motor power production. Standard product with three-phase voltage input has an allowable range of +10% to -15%. Therefore, a stricter input voltage tolerance of +10 to -5% applies when using the drive with a single-phase supply. The average bus voltage with single-phase input is lower than the equivalent of a three-phase input. Therefore, the maximum output voltage (motor voltage) will be lower with a single-phase input. The minimum input voltage must be no less than 228Vac for 230 volt models and 456Vac for 460 volt models, to ensure motor voltage production of 207Vac and 415Vac, respectively. Thus, if full motor torque must be developed near base speed (full power) it will be necessary to maintain a rigid incoming line voltage so that adequate motor voltage can be produced. Operating a motor at reduced speed (reduced power), or using a motor with a base voltage that is lower than the incoming AC supply rating (ex. 208Vac motor with a 240Vac supply), will also minimize the effect of voltage deprivation. (240VAC Input ► 208V motor, 480VAC Input ► 460V motor)

PROTECTION

Protection for output current like OCT or IOLT is based on 3-phase input ratings which is larger than single-phase input. User should set the parameters that are relative to motor information (bA.11~bA.16), overload trip (Pr.17~Pr.22) and E-thermal functions (Pr.40~Pr.43).

CONTROL TERMINAL WIRING

The following drawings show the layout of the control wiring terminals and control board switches. Refer to these diagrams before making control terminal wiring connections. Ensure that the cables selected meet or exceed the specifications in the control cable selection table before installation.

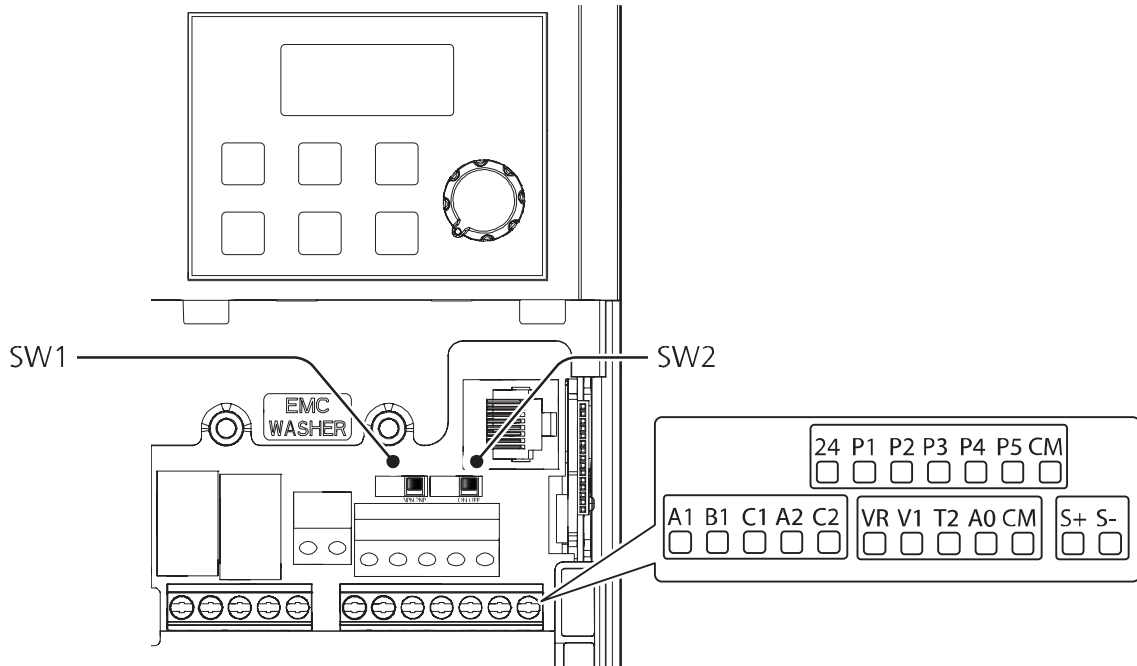

CONTROL BOARD SWITCHES

Control Board Switches	
Switch	Description
SW1	NPN/PNP mode selection switch
SW2	Terminating Resistor selection switch

CONNECTOR

Connector	
Name	Description
RJ45 Connector	Connection to software, remote keypad, or ACG-ET2 communication module.

FULL I/O WIRING DIAGRAM

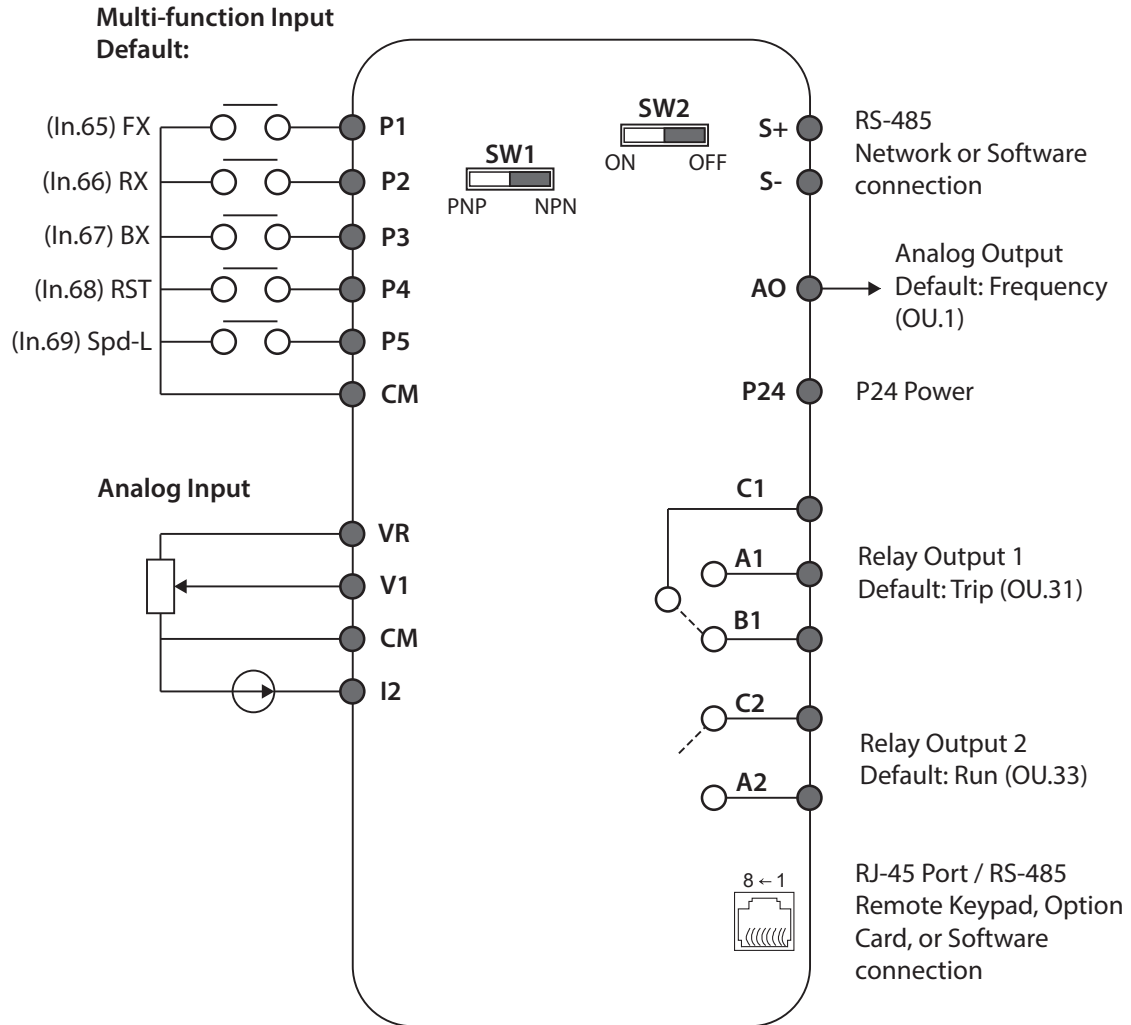

INPUT TERMINAL LABELS AND DESCRIPTIONS

Input Terminal Labels and Descriptions			
Function	Label	Name	Description
Multi-function terminal configuration	P1-P5	Multi-function Input 1-5	Configurable for multi-function input terminals. Factory default terminals and setup are as follows: <ul style="list-style-type: none"> • P1: FX, Fwd Run (In.65) • P2: RX, Rev Run (In.66) • P3: BX, Block (In.67) • P4: RST, Reset (In.68) • P5: Speed-L (In.69)
	CM	Common Sequence	Common terminal for terminal input, RS-485 communication, and analog terminal inputs and outputs.
Analog input configuration	VR	Terminal for frequency reference setting	Used to setup or modify a frequency reference via analog voltage or current input. <ul style="list-style-type: none"> • Maximum Voltage Output: 12V • Maximum Current Output: 100mA • Potentiometer: 1-5kΩ
	V1	Frequency setting (voltage) terminal	Used to setup or modify a frequency reference via analog voltage input terminal (In.1-In.17). <ul style="list-style-type: none"> • Unipolar: 0-10V (12V Max.) • Bipolar: -10-10V (\pm12V Max.)
	I2	Current input for frequency reference input Terminal	Used to setup or modify a frequency reference via the I2 terminal (In.50-In.62). <ul style="list-style-type: none"> • Input current: 4-20mA • Maximum Input current: 20mA • Input resistance: 249Ω

OUTPUT/COMMUNICATION TERMINAL LABELS AND DESCRIPTIONS

Output/Communication Terminal Labels and Descriptions			
Function	Label	Name	Description
Analog output	AO	Voltage output terminal	Used to send drive output information to external devices: output frequency, output current, output voltage, or a DC voltage (OU.1). <ul style="list-style-type: none"> • Output voltage: 0-10V • Maximum output voltage/current: 12V/10mA • Factory default output: Frequency
Digital Relay Outputs	24	24V internal power source	Maximum output current: 100mA
	A1/C1/B1	Relay output 1	Activates based on multi-function parameter setting (250VAC <1A, 30VDC < 1A)(OU.31). <ul style="list-style-type: none"> • A1/C1: Normally Open • B1/C1: Normally Closed • Default OU.31=29 (Drive Trip)
	A2/C2	Relay output 2	Activates based on multi-function parameter setting (250VAC <1A, 30VDC < 1A)(OU.33). <ul style="list-style-type: none"> • A2/C2: Normally Open • Default: OU.33=14 (Drive Run)
Communication	S+/S-	RS-485 signal input terminal	Used to send or receive RS-485 signals.
	RJ45	RJ45 Connector	Connection to Software, Remote keypad, or ACG-ET2 communication module.

PRE-INSULATED CRIMP TERMINAL CONNECTORS (BOOTLACE FERRULE)

Use pre-insulated crimp terminal connectors to increase reliability of the control terminal wiring. Use this drawing and table to determine the crimp terminals to fit various cable sizes.

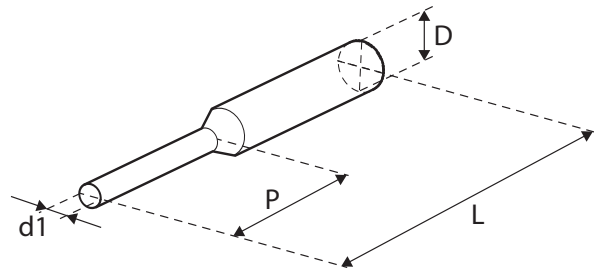

Cable Spec		Dimensions (mm)			
AWG	mm ²	L*	P	d1	D
22	0.50	12.0	6.0	1.3	3.2
20	0.75	12.0	6.0	1.5	3.4
18	1.0	12.0	6.0	1.7	3.6

* If the length (L) of the crimp terminals exceeds 0.5" (12.7mm) after wiring, the control terminal cover may not close fully

To connect cables to the control terminals without using crimp terminals, refer to this drawing showing the correct length of exposed conductor at the end of the control cable.

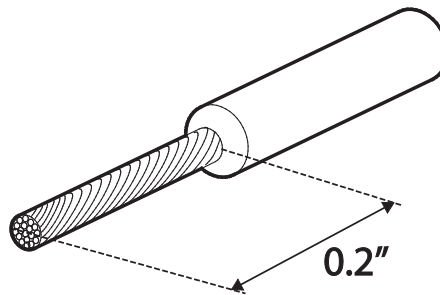

NOTE: Please read these general wiring recommendations:

- While making wiring connections at the control terminals, ensure that the total cable length does not exceed 165ft (50m).
- Ensure that the length of any safety related wiring does not exceed 100ft (30m).
- Ensure that the cable length between a remote keypad and the drive does not exceed 10ft (3.04 m). Cable connections longer than 10ft (3.04 m) may cause signal errors.
- Use ferrite material to protect signal cables from electro-magnetic interference.
- Take care when supporting cables using cable ties, to apply the cable ties no closer than 6 inches from the drive. This provides sufficient access to fully close the front cover.
- When making control terminal cable connections, use a small flat-tip screw driver (0.1 in wide (2.5 mm) and 0.015 in thick (0.4 mm) at the tip).

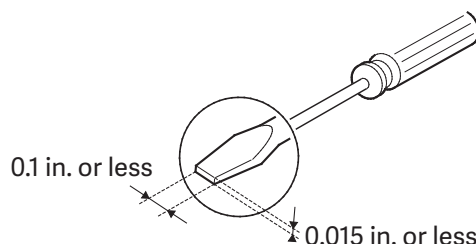

TERMINAL SCREW SPECIFICATION

Drive		Terminal Screw Specifications	
Input Voltage	hp	Size	Torque (Kgf·cm [Nm])
3-phase 230V	1/2	R/S/T, U/V/W: M3	R/S/T, U/V/W: 5.1 [0.5]
	1		
	2	R/S/T, U/V/W: M4	R/S/T, U/V/W: 12.1 [1.2]
	3		
	5		R/S/T, U/V/W: 18.4 [1.8]
	7.5		R/S/T: 14.3 [1.4] U/V/W: 15.0 [1.5]
	10	R/S/T, U/V/W: M5	R/S/T, U/V/W: 25.34 [2.5]
	15		
	20		
	25	R/S/T, U/V/W: M6	R/S/T, U/V/W: 5.1 [0.5]
	30		
3-phase 460V	1/2	R/S/T, U/V/W: M3.5	R/S/T, U/V/W: 10.3 [1.0]
	1		
	2		
	3		
	5	R/S/T, U/V/W: M4	R/S/T, U/V/W: 18.4 [1.8]
	7.5		R/S/T: 14.3 [1.4] U/V/W: 18.4 [1.8]
	10		
	15	R/S/T, U/V/W: M5	R/S/T, U/V/W: 25.34 [2.5]
	20		
	25		
	30		



WARNING: SA, SB, SC ARE SHORTED AND HAVE 24V VOLTAGE ACROSS THEM. DO NOT CONNECT POWER TO THE DRIVE UNTIL INSTALLATION HAS BEEN FULLY COMPLETED AND THE DRIVE IS READY TO BE OPERATED. DOING SO MAY RESULT IN ELECTRIC SHOCK.

PNP/NPN MODE WIRING AND SELECTION

The drive supports both PNP (Source) and NPN (Sink) modes for sequence inputs at the terminal. Select an appropriate mode to suit requirements using the PNP/NPN selection switch (SW1) on the control board. Refer to the following information for detailed applications.

PNP MODE (SOURCE)

Select PNP using the PNP/NPN selection switch (SW1). Note that the factory default setting is NPN mode. CM is the common ground terminal for all analog inputs at the terminal, and P24 is 24V internal source. If you are using an external 24V source, build a circuit that connects the external source (-) and the CM terminal.

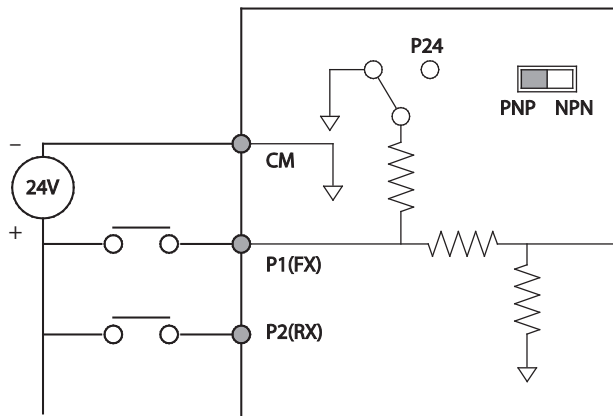

PNP Mode (Source)

NPN MODE (SINK)

Select NPN using the PNP/NPN selection switch (SW1). Note that the factory default setting is NPN mode. CM is the common ground terminal for all analog inputs at the terminal, and P24 is 24V internal source.

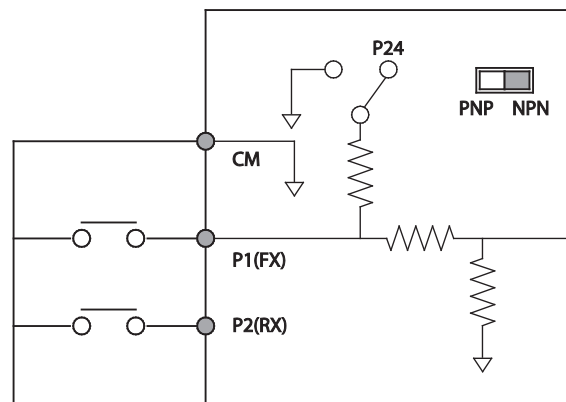

NPN Mode (Sink)

RUN COMMAND WIRING

Use one of the following examples to wire the run command for the drive in either 2-wire or 3-wire mode.

2-WIRE CONTROL

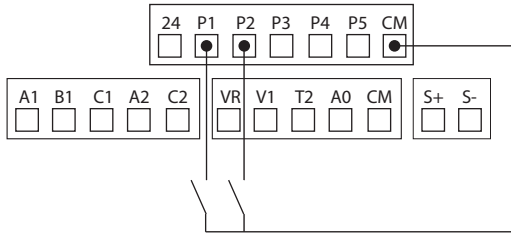

2-wire control consists of maintained run signals. This can be accomplished via toggle switches, relays, jumpers, etc. Default parameters support this operation.

P1=Forward Run (Fx)

P2=Reverse Run (Rx)

CM=Common

3-WIRE CONTROL

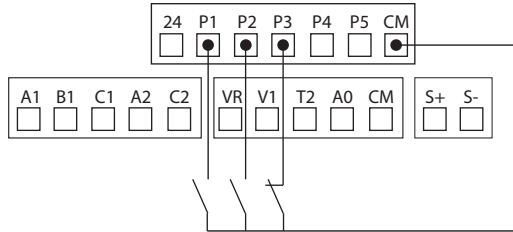

3-Wire control consists of momentary push buttons to run and stop the VFD. The Forward and Reverse buttons are Normally Open while the Stop button is Normally Closed. Set parameter In.67=14 if using P3 (like below) for the Stop button.

P1 = Forward Run (Fx)

P2 = Reverse Run (Rx)

P3 = Stop (3-Wire)

CM = Common Frequency Reference Wiring

RELAY OUTPUT WIRING

OUTPUT WIRING USING EXTERNAL POWER

Ensure device current does not exceed 1A.

Relay 1

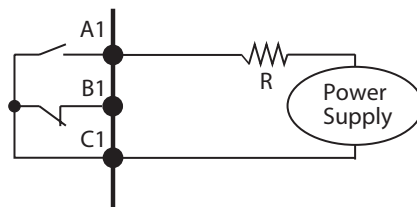

Relay 2

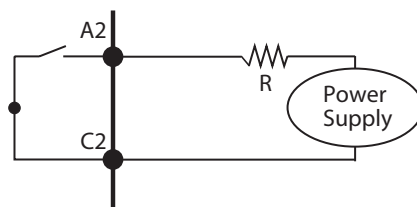

ANALOG WIRING

This section demonstrates how to wire up a 4-20mA or 0-10VDC source to the ACG VFDs. This document focuses on transducer, speed POT, and PLC connection sources but can be applied to any 4-20mA or 0-10VDC device.

4-20mA ANALOG INPUT WIRING

Transducer (4-20mA): Transducers are typically 4-20mA devices which require a 24VDC power source. For 2-wire transducers connect to the 24VDC and 4-20mA input terminals listed below. Connect the positive lead of the device to the 24V terminal and the signal lead to the analog input terminal (I2).

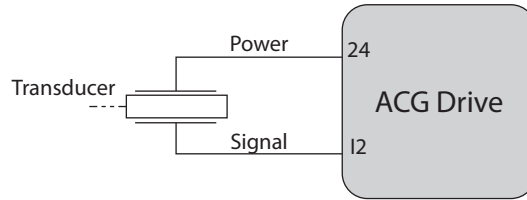

PLC (4-20mA): The wiring for connecting a PLC’s 4-20mA output to the analog input of a VFD differs slightly from the transducer wiring discussed above. The positive (signal) lead is wired to the corresponding analog input while the negative (common) lead is wired to the drives common. Reference the figure below.

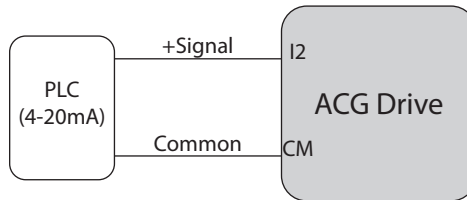

0-10VDC ANALOG INPUT WIRING

Speed POT/Rheostat (0-10VDC): Speed potentiometers have three wires which must be connected to properly vary a 0-10VDC signal. The required terminal connections will vary slightly depending on the drive series. Reference the figure below. The wiper of the speed POT should always be connected to the analog input.

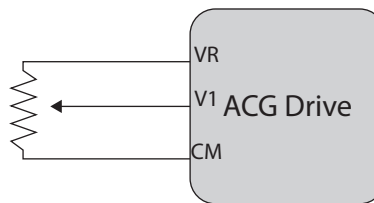

PLC (0-10VDC): The wiring for connecting a PLC’s 0-10VDC output to the analog input of a VFD differs slightly from the speed POT wiring discussed above. The positive (signal) lead is wired to the corresponding analog input while the negative (common) lead is wired to the drives common. Reference the figure below.

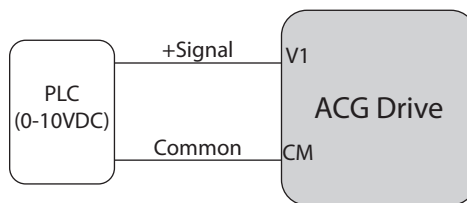

AO WIRING

Wire the drive analog out as follows:

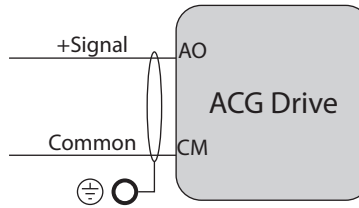

SYSTEM WIRING DIAGRAM

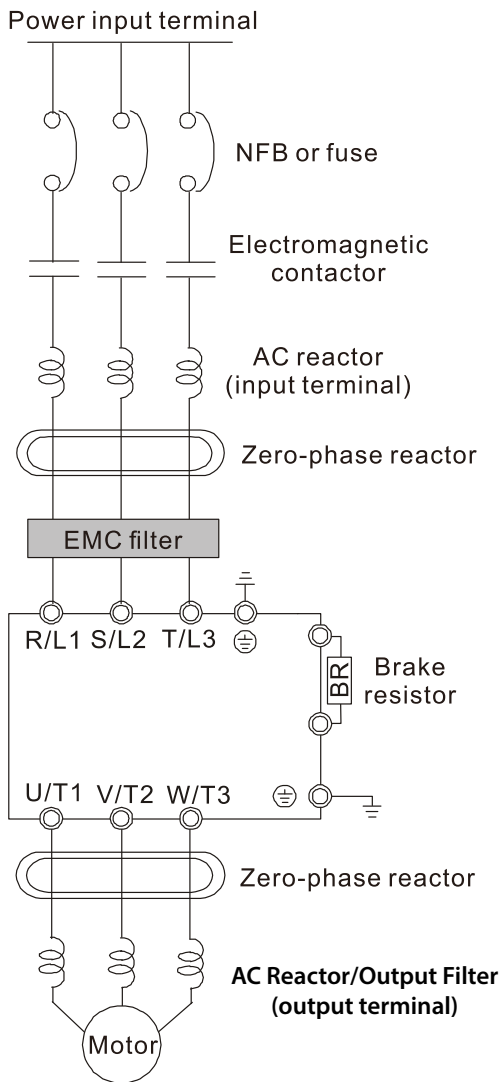

System Wiring Components	
Component	Function
Power input terminal	Supply power according to the rated power specifications indicated in the manual
NFB or fuse	There may be a large inrush current during power on. Select a suitable NFB (non-fuse breaker or circuit breaker) or Fuse.
Electromagnetic contactor	Switching the power ON/OFF on the primary side of the electromagnetic contactor can turn the drive ON/OFF, but frequent switching can cause machine failure. Do not switch ON/OFF more than once an hour. Do not use the electromagnetic contactor as the power switch for the drive; doing so shortens the life of the drive.
AC reactor (input terminal)	When the main power supply capacity is greater than 500kVA, or when it switches into the phase capacitor, the instantaneous peak voltage and current generated may destroy the internal circuit of the drive. It is recommended that you install an input side AC reactor in the drive. This also improves the power factor and reduces power harmonics. The wiring distance should be within 10m.
Zero phase reactor	Used to reduce radiated interference, especially in environments with audio devices, and reduce input and output side interference. The effective range is AM band to 10MHz.
EMC filter	Can be used to reduce electromagnetic interference.
Brake module and Brake resistor (BR)	Used to shorten the deceleration time of the motor.
AC Reactor/ Output Filter (output terminal)	The motor cable length affects the size of the reflected wave on the motor end. For motor distances greater than 100 feet, the VTF series dV/dT filter is recommended.

RE-ASSEMBLING THE COVER

Re-assemble the cover after completing the wiring and basic configurations.

POST-INSTALLATION CHECKLIST

After completing the installation, check the items in the following table to ensure that the drive has been safely and correctly installed.

Post-Installation Checklist	
Items	Checkpoint
Installation Location/Power I/O Verification	Is the installation location appropriate?
	Does the environment meet the drive's operating conditions?
	Does the power source match the drive's rated input?
	Is the drive's rated output sufficient to supply the equipment? (Degraded performance will result in certain circumstances.)
Power Terminal Wiring	Is a circuit breaker installed on the input side of the drive?
	Is the circuit breaker correctly rated?
	Are the power source cables correctly connected to the R/S/T terminals of the drive? (Caution: connecting the power source to the U/V/W terminals may damage the drive.)
	Are the motor output cables connected in the correct phase rotation (U/V/W)? (Caution: motors will rotate in reverse direction if three phase cables are not wired in the correct rotation.)
	Are the cables used in the power terminal connections correctly rated?
	Is the drive grounded correctly?
	Are the power terminal screws and the ground terminal screws tightened to their specified torques?
	Are the overload protection circuits installed correctly on the motors (if multiple motors are run using one drive)?
	Is the drive separated from the power source by a magnetic contactor (if a braking resistor is in use)?
	Are advanced-phase capacitors, surge protection, and electromagnetic interference filters installed correctly? (These devices MUST not be installed on the output side of the drive.)
If motor distance is greater than 100 feet from the drive, is VFD cable and/or line reactor/filter used?	
Is total motor cable length less than 165ft (5HP or less) or 665 feet (7.5HP or greater)?	
Control Terminal Wiring	Are STP (shielded twisted pair) cables used for control terminal wiring?
	Is the shielding of the STP wiring properly grounded?
	If 3-wire operation is required, are the multi-function input terminals defined prior to the installation of the control wiring connections?
	Are the control cables properly wired?
	Are the control terminal screws tightened to their specified torques?
	Is the total cable length of all control wiring < 165ft (100m)?
Is the total length of safety wiring < 100ft (30m)?	
Miscellaneous	Are optional cards connected correctly?
	Is there any debris left inside the drive?
	Are any cables contacting adjacent terminals, creating a potential short circuit risk?
	Are the control terminal connections separated from the power terminal connections?
	Have the capacitors been replaced if they have been in use for > 2 years?
	Have the fans been replaced if they have been in use for > 3 years?
	Has a fuse been installed for the power source?
Are the connections to the motor separated from other connections?	



NOTE: STP (Shielded Twisted Pair) cable has a highly conductive, shielded screen around twisted cable pairs. STP cables protect conductors from electromagnetic interference.

TEST RUN

After the post-installation checklist has been completed, follow the instructions below to test the drive (This requires use of the keypad. See Chapter 3 for instructions on keypad operation).

- 1) Turn on the power supply to the drive. Ensure that the keypad display light is on.
- 2) Select the command source with parameter drv (operation group menu).
- 3) Set a frequency reference, and then check the following:
 - a) If V1 is selected as the frequency reference source, does the reference change according to the input voltage at VR?
 - b) If I2 is selected as the frequency reference source, does the reference change according to the input current?
- 4) Set the acceleration and deceleration time using parameters ACC and DEC in the operation menu.
- 5) Start the motor and check the following:
 - a) Ensure that the motor rotates in the correct direction (refer to the note below).
 - b) Ensure that the motor accelerates and decelerates according to the set times, and that the motor speed reaches the frequency reference.



NOTE: If the forward command (Fx) is on, the motor should rotate counterclockwise when viewed from the load side of the motor. If the motor rotates in the reverse direction, switch the cables at the U and V terminals.

VERIFYING THE MOTOR ROTATION

- 1) On the keypad, set the Frq (Drive Command reference source) parameter in the Operation group to 0 (Keypad).
- 2) Set a frequency reference to a low value (10Hz).
- 3) Press the [RUN] key. Motor starts forward operation.
- 4) Observe the motor's rotation from the load side and ensure that the motor rotates counterclockwise (forward).
If the motor rotates in the reverse direction, two of the U/V/W terminals need to be switched.

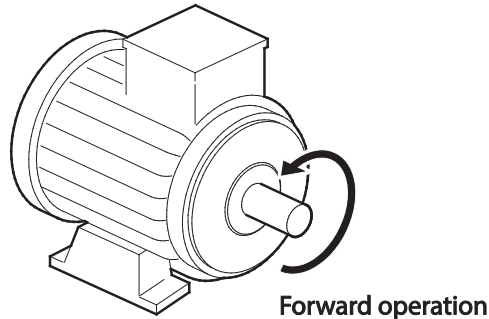

CAUTION: READ THE FOLLOWING INFORMATION BEFORE OPERATING YOUR DRIVE:

- Check the parameter settings before running the drive. Parameter settings may have to be adjusted depending on the load.
- To avoid damaging the drive, do not supply the drive with an input voltage that exceeds the rated voltage for the equipment.
- Before running the motor at maximum speed, confirm the motor's rated capacity. As drives can be used to easily increase motor speed, use caution to ensure that motor speeds do not accidentally exceed the motor's rated capacity.