

M3X0.5-8  
SHSS X3

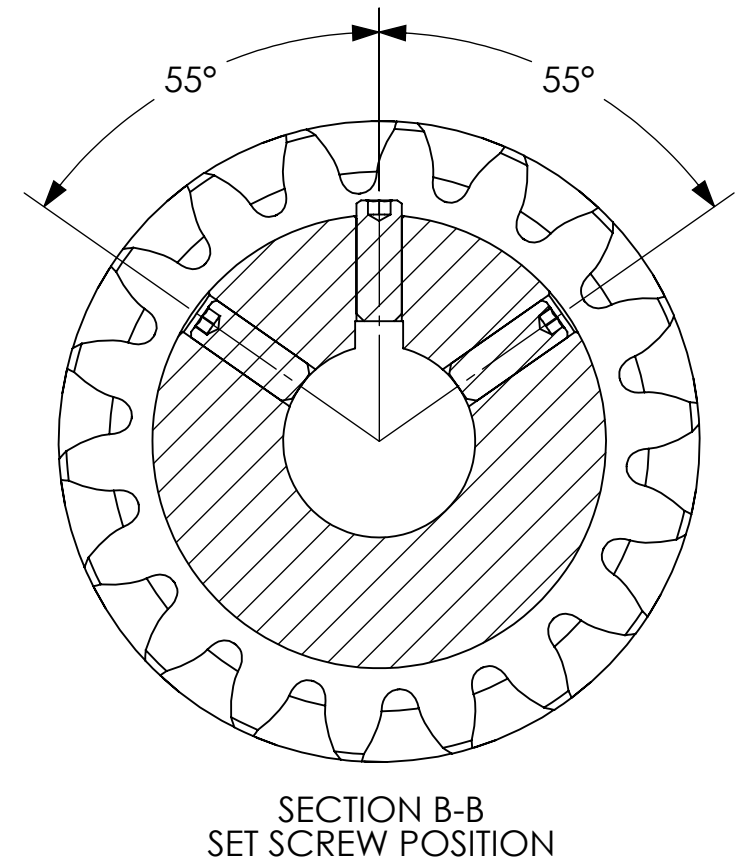
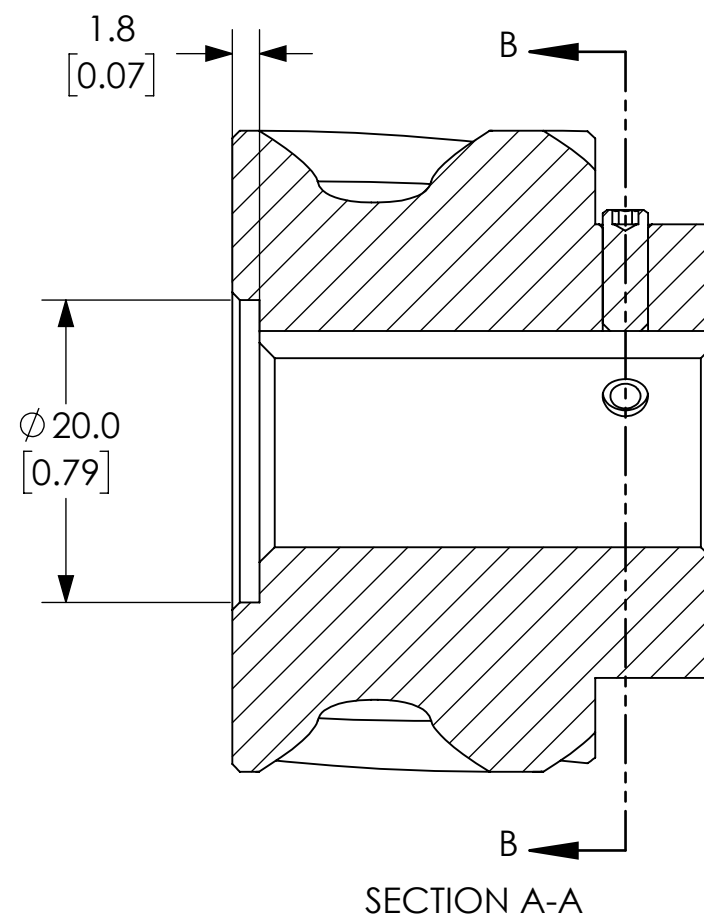
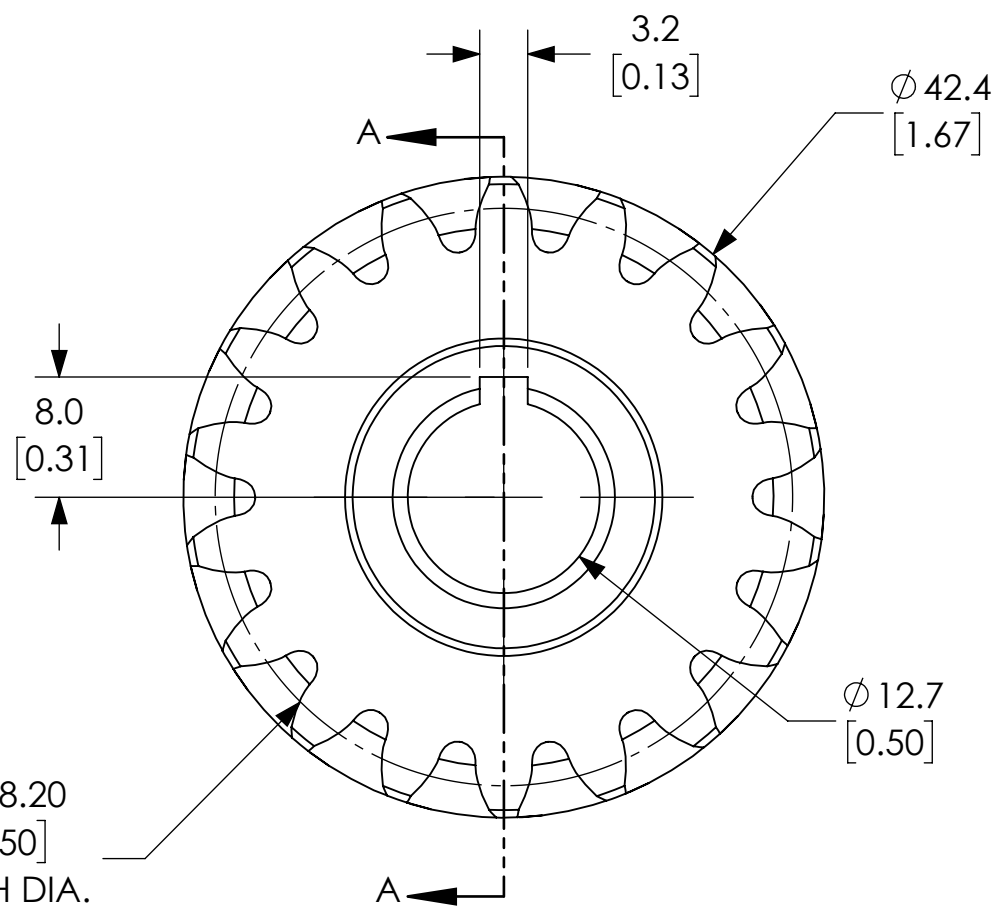

NOTES:

1. DIMENSIONS CAN BE CHANGED BY MANUFACTURER WITHOUT NOTICE.
2. DIMENSIONS DO NOT IMPLY TOLERANCE.

84010002

Units: mm [inches]  
Scale: Full

GAM HELICAL PINION, MODULE 2,  
18 TOOTH, SET SCREW MOUNT