

GENERAL NOTES:

1. ANALOG OUTPUT IS MAXIMUM WITH PROBE RETRACTED; SEE TECHNICAL DATA SHEET TO SPECIFY REVERSED OUTPUT.

2. SENSOR SUPPLIED WITH AGD #9 CONTACT TIP. (4-48 UNF THD)

3. SPECIFICATIONS ARE SUBJECT TO CHANGE WITHOUT NOTICE.

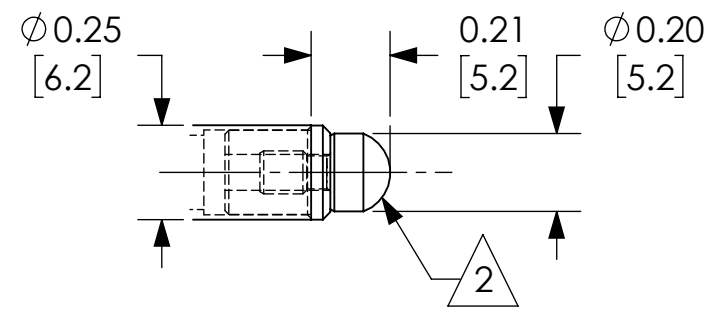

DETAIL A
SCALE 2:1

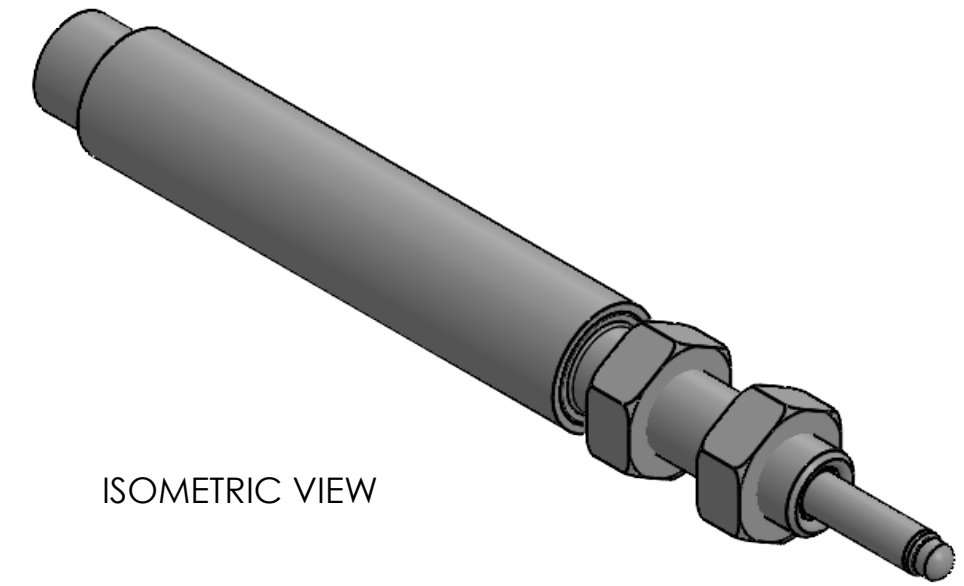

ISOMETRIC VIEW

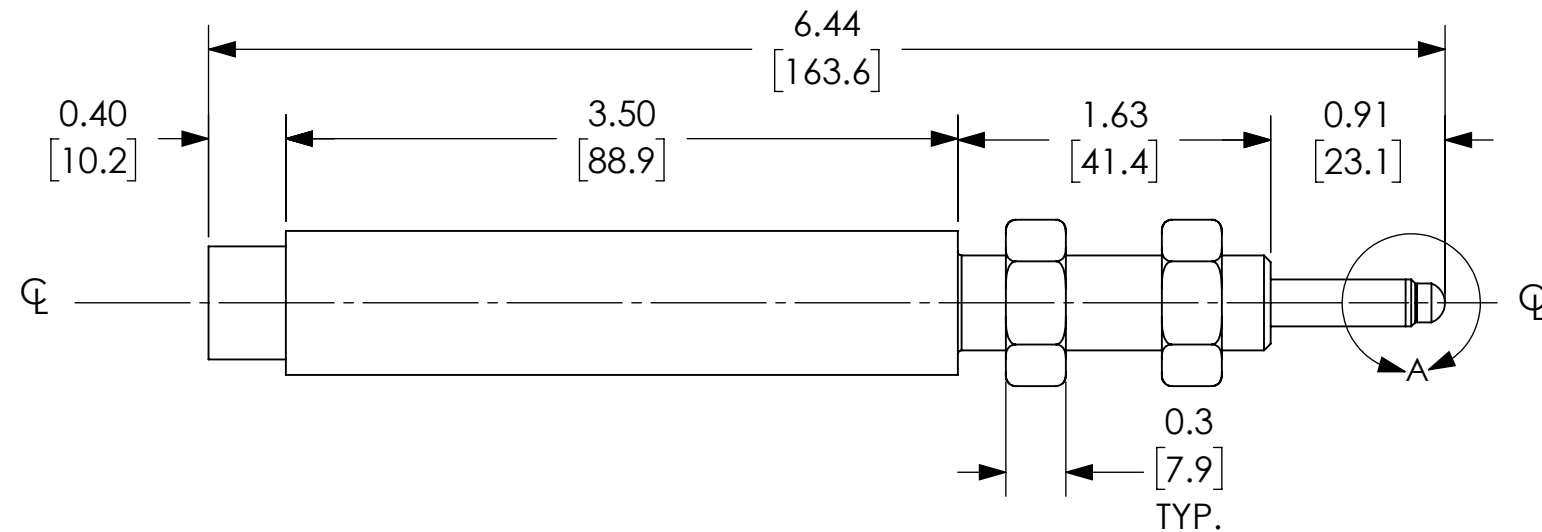

EXTENDED VIEW

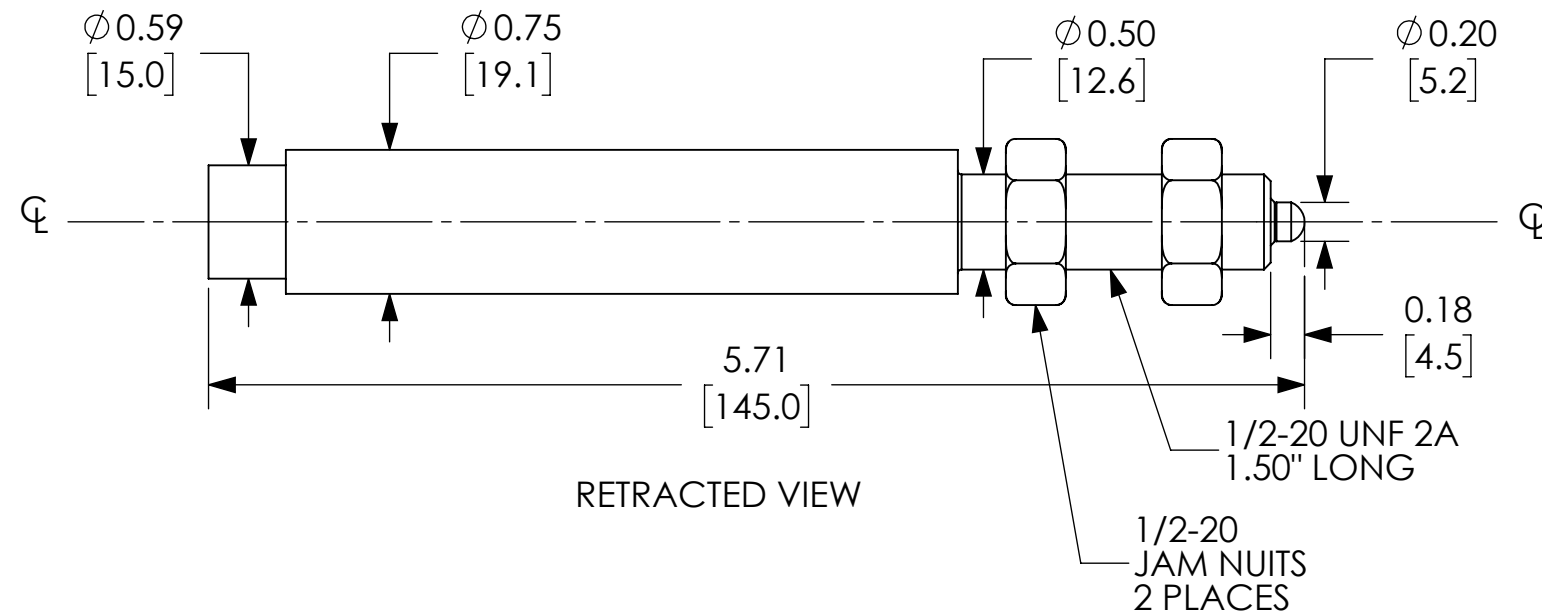
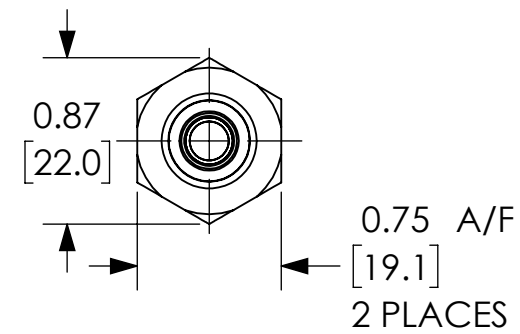

RETRACTED VIEW

NOTES:

1. DIMENSIONS CAN BE CHANGED BY MANUFACTURER WITHOUT NOTICE.

2. DIMENSIONS DO NOT IMPLY TOLERANCE.

GHS119-013A-02-20S

Units: inches [mm]

Scale: Full

LINEAR TRANSDUCER, 3/4" OD SS
BODY, 1/2" RANGE, SPRING
LOADED, AXIAL PTO CONNECTOR