

Ø 22.2
[0.88]
BORE

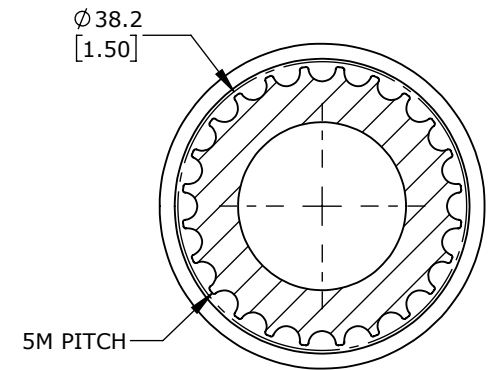
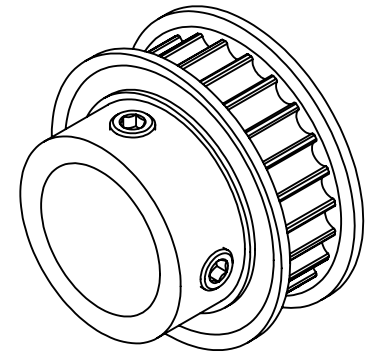
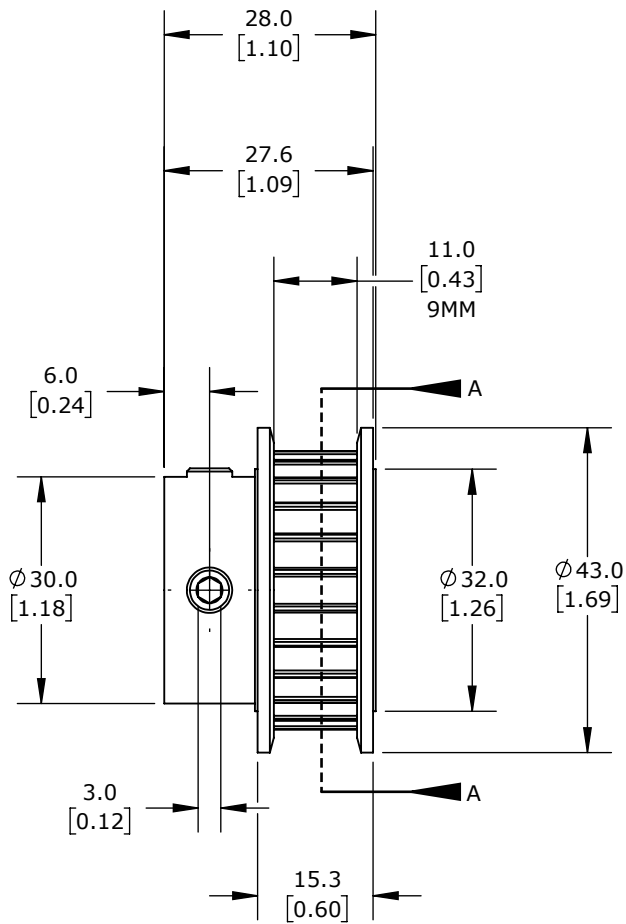

SECTION A-A

HARDWARE INCLUDED	
TYPE	QTY
M6-1.0 SET SCREW	2

TIMING PULLEY, 5M, 24 TOOTH

A24-5M10-SS-0875

AutomationDirect.com
1-800-633-0405



3rd
ANGLE

NOT TO
SCALE

PART DIMENSIONS MAY DIFFER SLIGHTLY
DUE TO MANUFACTURER'S VARIANCES

METRIC UNITS USED
FOR PART DESIGN

UNLESS OTHERWISE
SPECIFIED UNITS ARE:

mm
[inch]

LATEST VERSION
3/27/2024

SHEET 1 OF 1