

DETAIL A
SCALE 2:1

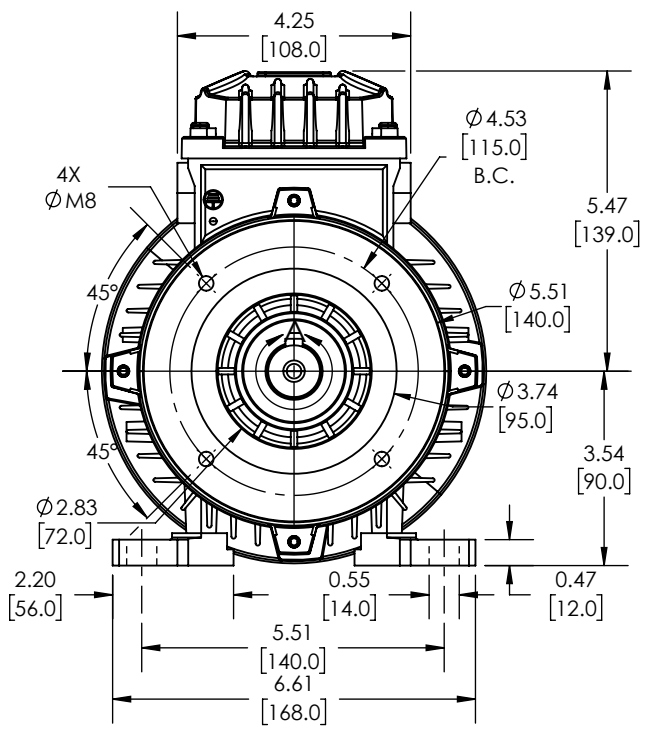

M.G.M. ELECTRIC MOTORS SMX SERIES IE3 PREMIUM EFFICIENCY AC INDUCTION MOTOR, GENERAL PURPOSE AND INVERTER RATED, 2HP, 3-PHASE, 230/460 VAC, 3600RPM, TEFC, IEC 90 FRAME, ALUMINUM, C-FACE/REMOVABLE RIGID BASE (B34) MOUNT

1B2I

AutomationDirect.com
1-800-633-0405

	3rd	NOT TO SCALE	PART DIMENSIONS MAY DIFFER SLIGHTLY DUE TO MANUFACTURER'S VARIANCES	METRIC UNITS USED FOR PART DESIGN	UNLESS OTHERWISE SPECIFIED UNITS ARE:	inch	MODEL REV.	LATEST VERSION 5/13/2026	SHEET 1 OF 1
	ANGLE					[mm]			