

DETAIL A  
SCALE 2:1

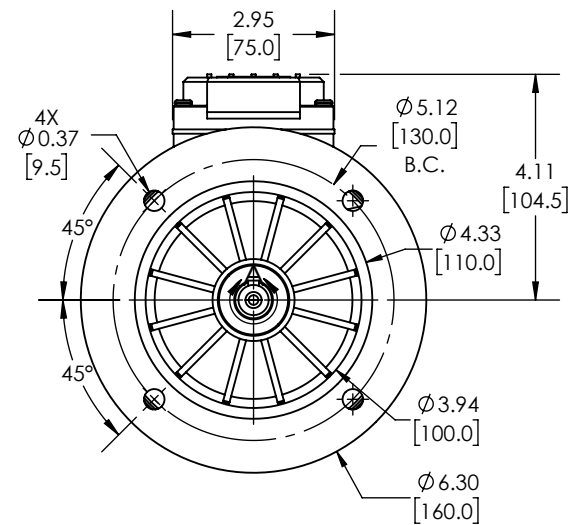
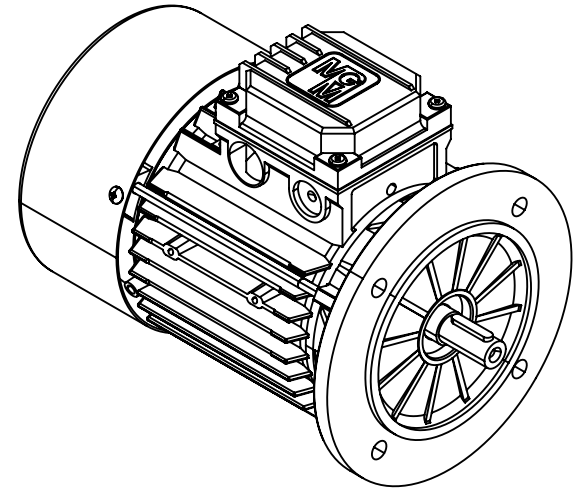

M.G.M. ELECTRIC MOTORS SMX SERIES IE2 HIGH EFFICIENCY AC INDUCTION MOTOR, GENERAL PURPOSE AND INVERTER RATED, 1/3HP, 3-PHASE, 230/460 VAC, 1800RPM, TEFC, IEC 71 FRAME, ALUMINUM, D-FLANGE (B5) MOUNT

0R5R

AutomationDirect.com  
1-800-633-0405



3rd  
ANGLE

NOT TO  
SCALE

PART DIMENSIONS MAY DIFFER SLIGHTLY  
DUE TO MANUFACTURER'S VARIANCES

METRIC UNITS USED  
FOR PART DESIGN

UNLESS OTHERWISE  
SPECIFIED UNITS ARE:

inch  
[mm]

MODEL  
REV.

LATEST VERSION  
5/12/2026

SHEET 1 OF 1