

Drive features

- Power: 3 or 6 Amps, 24-80 VDC
- Supports EtherCAT, pulse input, and indexing control modes
- Switch between semi-closed loop control, fully-closed loop control, and dual feedback control
- Fully-closed loop control provides quick response with internal and external encoder position values as well as ensuring high-precision control during machine operation
- Dual feedback control - uses the motor encoder and allows the highest gains during motion, but uses the secondary encoder for precise positioning when the motor stops.
- Free Drive CM configuration software
- Multiple encoder support: the drive can accept standard incremental quadrature encoder input and can also accept BiSS Absolute (single turn or multi-turn 16-bit), BiSS general, Panasonic single-turn or multi-turn, Nikon, or SSI encoder formats
- High speed pulse input:
 - Positioning control through high speed pulses from a PLC or motion controller. Acceptable formats: quadrature (A+B), CW/CCW, Pulse+Direction
 - Provides position control through I/O without position control module
- Indexing control:
 - Select and command multiple moves with general purpose digital inputs (not high-speed)
 - Configure the move distances, speeds, accel/decels with DriveCM software and select them at runtime with digital inputs (from a PLC, selector switches, etc.)
- Analog input and preset speed/torque:
 - Use the analog input to control motor speed or torque when in Speed Mode or Torque Mode, or configure preset speed/torque values with DriveCM and select them with digital inputs
 - The analog input can also be used as a speed override signal to modify the motor speed when the drive is Indexing Control
 - The analog input can be used as a torque limit when the drive is in Indexing Mode (or in EtherCAT Profile Position Mode)
- Real-time control through EtherCAT:
 - High speed, real-time control and synchronization mechanism
 - Supports CoE, EoE, and FoE
 - Synchronous and Profile modes
 - Improved frequency response (1kHz)
 - Improved communication speed by applying 16-bit bus
- The 1 kHz bandwidth (frequency response) allows for high-level automatic tuning. Several modes of tuning are available including Off-Line Auto Tuning (the drive initiates its own move commands while Auto tuning), On-Line Auto Tuning (an external controller sends the move commands while the drive Auto tunes), and Manual Tuning (all tuning values are adjusted by the user).
- Variable switching frequency of motor power signals - 16/32/48 kHz. User can adjust the frequency to minimize electrical noise or interference.
- (4) Optically isolated configurable digital inputs and (4) user configurable outputs
- Advanced Scope feature that can monitor a variety of command and status signals, including output speed, torque, power, etc.



- STO: Safe Torque Off input eliminates the need for large contactors to drop power from the drive when an E-stop occurs
- Separate brake output connector: no interposing relay needed when using the dedicated 1A output for motor holding brake.
- Analog Outputs: use the two analog outputs to monitor

Motor features

- Low inertia 3000rpm motors available:
 - 100W, 40mm frame size
 - 100W, 200W, and 300W, 60mm frame size
- Permanent magnet 3-phase synchronous motor
- Keyed drive shafts support clamp-on style couplings or key-style couplings (100W FAL01 motors have smooth shafts, no key)
- Integrated multi-turn absolute encoder with 19-bit resolution (524,288 pulses per revolution) except FAL01 motors with 18-bit (262,144 ppr)
- Optional 24 VDC spring-set holding brakes (AM8N2 and AMK2 motors)
- Professionally manufactured cables available for motor power, encoder feedback, and (optional) brake, in standard or continuous flexing versions (3m, 5m, 10m, or 20m lengths)
- Standard 26-pin DIN-rail mounted break-out kit for the drive's CN1 connector (with screw terminal connections), or 26-pin cables with flying leads

Note: These parts available for sale to North American locations only.

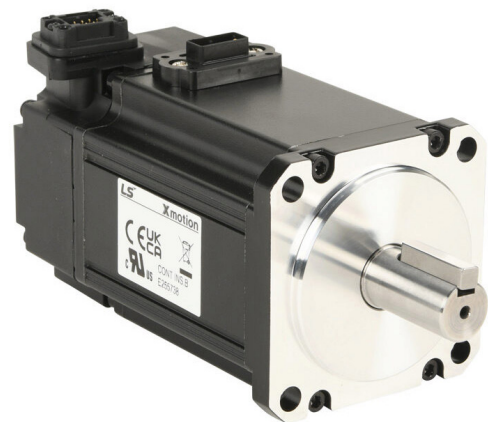

Tuning Technology

The PHOX drive closes the loop on current, velocity, and position (depending on control mode selection). The 1kHz bandwidth in the drive assures precise speed and current control and easy tuning. Proportional gain, integral gain and compensation, feed forward compensation, command low pass filter, and four (4) notch filters (and Adaptive notch filters) for resonance suppression are available. Auto Tuning has been greatly improved and can tune motors up to 30:1 inertia mismatch.

There is an inertia estimation function that analyzes the motor and load during Auto Tuning to measure how much inertia is coupled to the motor.

The drive has several tuning methods available:

- Online Auto Tuning—the drive can either tune the load live while an external controller moves the load to different positions or using the drive's internal tuning motion profile.
- Offline Auto Tuning—the drive tunes the load using the drive's internal tuning motion profile.
- Manual Tuning—all parameters are available to give power users the ultimate flexibility to tune their systems.

Control Modes

When connected to an EtherCAT® Master, the PHOX drive can run in Cyclic Synchronous Modes (Position, Velocity, Torque) where the Master controller sends an updated setpoint every EtherCAT® cycle (~1millisecond). In these modes, the upper controller plans the motion path.

The drive can also work in EtherCAT Profile Modes (Position, Velocity, Torque) where the Master Controller sends one setpoint for each move. In these cases, the drive's accel, decel, and max speed settings determine the motion path planning. The drive also has 21 different homing modes to accommodate most applications.

In non-EtherCAT applications the PHOX can work as a standard servo, accepting high-speed pulse inputs, Indexing commands (general purpose Digital inputs to initiate and select different Index moves), analog or preset modes, or analog or preset torque modes.

Optional Holding Brake

Each servo motor can be ordered with an integrated 24VDC spring-set holding brake that holds the motor in place when power is removed.

LS Electric MSS Series In-Line Planetary Precision Gearboxes for Servo Motors

Need more torque from the motor? Have an inertia balancing issue in your design? The LS Electric MSS series gearboxes easily mate to 60mm FBL motors. SureGear gearboxes are available for the 40mm 100W FAL motors. Everything you need for mounting is included!



- Three MSS gear ratios available (5:1, 10:1, 20:1)
- Five SureGear gear ratios available for 40mm 100W FAL motors (5:1, 10:1, 15:1, 25:1, 50:1)
- Mounting hardware included for attaching to motors.
- Industry-standard mounting dimensions
- Thread-in mounting style
- Very low backlash: 7 arc-min or 9 arc-min (20:1 ratios).
- 1-year warranty

Servo drive overview

Motor Output Terminal

Output power to the servo motor. LS motor power cables available in 3, 5, 10, and 20 meter lengths in standard and flexing cables.

Brake Output Connector

Separate connector to wire a motor brake. Can handle 1A current output (no need for an interposing relay). Optional brake cables are available (APCS-BxxxQS-AD). The mating brake connector (PHOX-CON-C) and crimp pins (PHOX-CON-D) are included with each drive.

EtherCAT® Com Ports

(ECAT IN, ECAT OUT). Used for connection to the EtherCAT controller. 4 Status LEDs indicate the operational status of the EtherCAT network and its error state.

Addressing Switches

DIP switches 1–7 set the EtherCAT Node Address. DIP switch 8 is for factory use only - do not turn ON.

USB Connector

Configuration: connect to PC (with Drive CM software) via a standard USB A to USB mini-B cable (SV2-PGM-USB15, MOSAIC-CSU, or similar).

Firmware Upgrade: Use Drive CM software or attach a USB thumb drive with the new FW and update using USB On the Go (no PC required). See the User Manual for details.

Safe Torque Off Connector (STO)

Optional STO cable is available (APCS-PHOX-STOxxA-AD). The mating STO connector (PHOX-CON-B) and crimp pins (PHOX-CON-D) are included with each drive.

Input/Output Connector (I/O)

26-pin CN1 connector for drive I/O. Signals include high speed pulse inputs, 4 configurable digital inputs, 4 configurable digital outputs, 1 analog input (torque limit), and scalable encoder output.

Control Power Terminal

Optional 24-80VDC control power (this is the AUX+ AUX- terminals on the power terminal strip)

Power Terminal

Incoming 24-80 VDC
(these are the HV+ HV- terminals on the power strip)

Status LED

Indicates current state of the drive: Green blinking indicates the operational status of the drive. Red blinking indicates error status. See the user manual for descriptions of the blinking codes.

Encoder Connector

HD15 connectors ENC A and ENC B for motor and secondary encoder. LS Encoder cables available in 3, 5, 10, and 20 meter lengths in standard and flexing cables.

The LS Electric PHOX servo drives are fully digital and include over 300 parameters to configure the drive for almost any application. For convenience, the parameters are grouped into several categories including:

- Basic parameters
- Gain parameters
- I/O parameters
- Velocity parameters
- Misc. parameters
- Monitor parameters

All parameters have commonly used default values which allow you to operate the PHOX drive "out-of-the-box". The drive auto-detects the LS servo motor (through the serial encoder) and sets up the default gains and limits based on the connected motor.

Additionally, the drive can be custom configured to your specific application. The Drive CM configuration software has a built-in Setup Wizard that will guide you through all the basic setup parameters. The Setup Wizard will quickly and easily get your application started – from setting up the I/O to determining the appropriate homing sequence.

It's also possible to configure these drives across an EtherCAT network via a compatible EtherCAT controller (such as XBF-PN04B or XBF-PN08B EtherCAT cards and the XGB PLC). This has the added advantage of consolidating/storing multiple drive configurations in a single repository.

After configuration is complete, the Auto Tune features of the drive will get your application tuned for optimal responsiveness and performance.

Servo motor overview

FAL/FBL Series Motor

Encoder Connector

9-pin watertight connector for the serial encoder. The encoder transmits motor/encoder identification information to the drive at power-up and sends position feedback during operation.

FAL 100W = 18-bit serial encoder (262,144 pulses per revolution)

All other motors = 19-bit serial encoder resolution (524,288 pulses per revolution).

All encoders have 16-bit multi-turn resolution (the shaft can turn $2^{16} = 65536$ full revolutions before the count rolls over)

Motor Power Connector

4-pin watertight connector for motor power (U, V, W, and ground)

Brake Power Connector

2-pin watertight connector available on FAL/FBL brake motors only. The 24VDC brake is located between the motor coils and the encoder. Motors ending in NM82 and AMK2 have brakes. The brakes must have 24VDC applied to them before the motor is set in motion.

Low Inertia Motors

Low inertia designs result in high responsiveness at high speeds for lighter loads.

- 100–300W motors available
- FAL motors have 40mm flanges
- FBL motors have 60mm flanges

Motor Shafts

FBL motors are supplied with extra-large keyways, and slightly oversized keys which may need to be "fitted" into the keyway for performance and longevity. Clamp or compression couplings (without key) are recommended. FAL motors do not have a key/keyway.

- 100W FAL 8mm diameter shaft
- 100W FBL 14mm diameter shaft
- 200W FBL 14mm diameter shaft
- 300W FBL 14mm diameter shaft

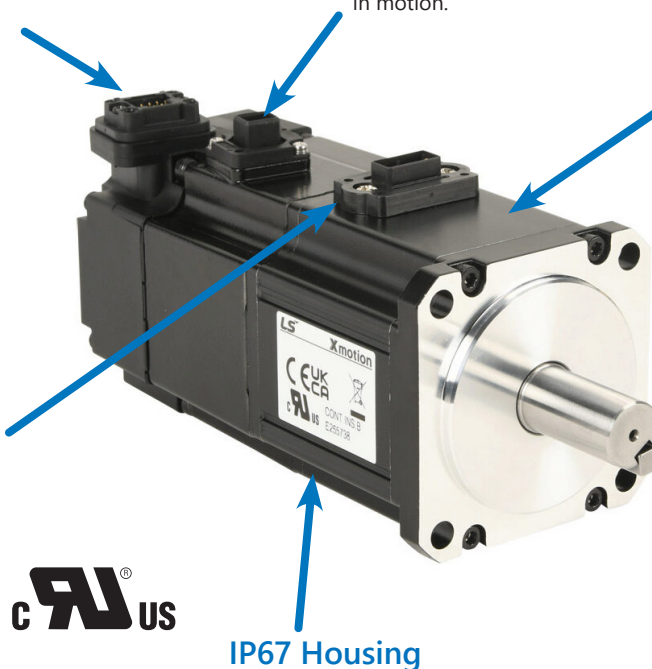

IP67 Housing

All LS Electric FBL motors have keyed shafts for use with servo-grade clamp or compression couplings (recommended) or servo-grade keyed couplings. Some sanding/filing of the key may be required before pressing into the keyway. Do not modify the shaft/keyway.

How to select and apply PHOX systems

The primary purpose of the AC servo system is to precisely control the motion of the load. The most fundamental considerations in selecting the servo system are "reflected" load inertia, servo system maximum speed requirement, servo system continuous torque requirement, and servo system peak torque requirement. In a retrofit application, select the largest torque servo system that most closely matches these parameters for the system being replaced. In a new application, these parameters should be determined through calculation and/or

measurement. The Drive CM software has the ability to measure the load (reflected) inertia and accurately measure the motor torque output.

AutomationDirect has teamed with Copperhill Technologies to provide free servo-sizing software. "VisualSizer-SureServo" software will assist in determining the correct motor and drive for your application by calculating the reflected load inertia and required speed and torque based on the load configuration. "VisualSizer-SureServo" software can be downloaded from <https://support.automationdirect.com/products/lselectric.html>.

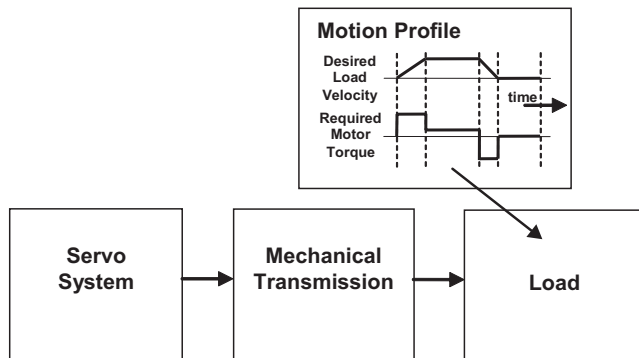

1. "Reflected" load inertia

The inertia of everything attached to the servo motor driveshaft needs to be considered and the total "reflected" inertia needs to be determined. This means that all elements of any mechanical transmission and load inertia need to be translated into an equivalent inertia as if attached directly to the motor driveshaft. The ratio of "reflected" load inertia to motor inertia needs to be carefully considered when selecting the servo system.

In general, applications that need high response or bandwidth

will benefit from keeping the ratio of load inertia to motor inertia as low as possible and ideally under 10:1. PHOX Auto Tuning will still tune a system with very high response, up to 30:1 inertia mismatch. Higher system ratios can be implemented, but corresponding lower bandwidth or responsiveness must be accepted. The servo response including the attached load inertia is determined by the servo tuning. The PHOX servo systems may be tuned automatically by the software/drive or manually by the user.

2. Torque and speed

With knowledge of the motion profile and any mechanical transmission between the motor and load, calculations can be made to determine the required servo motor continuous torque, peak torque, and maximum motor speed. The required amount of continuous torque must fall inside the continuous operating region of the system torque-speed curve (you can check the continuous torque at the average speed of the motion profile). The required amount of peak torque must also fall within the servo system's intermittent operating region of the system torque-speed curve (you need to check this value at the required maximum speed or torque). If you have a PHOX system, these values are easily captured and recorded with the Scope feature built into the Drive CM software. If you are designing the system from scratch, use VisualSizer to define the system and calculate expected inertia and required power.

Compare the application's continuous and intermittent torque requirements to the torque-speed curves found in Chapter 12.8 of the PHOX User Manual or in the system torque charts found on "PHOX AC servo drive, motor, and cable combinations" on page tSRV-28.

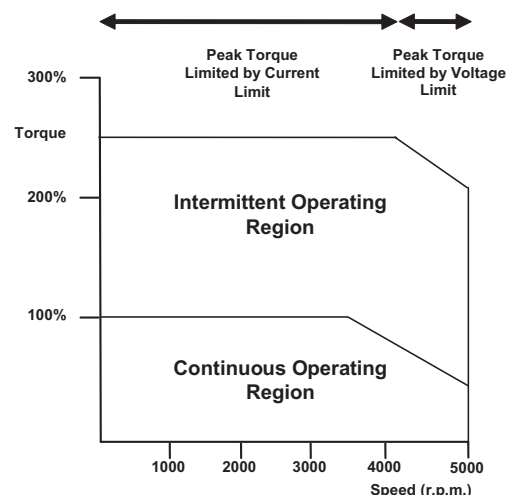

Application tip - coupling considerations

The LS Electric FBL motors have keyed shafts that can be used with keyed couplings or with clamp-on or compression style couplings. FAL motors are smooth shaft only. For standard keyed couplings, the servo key must be "fitted" into the keyway for optimum performance and longevity. Some minor filing and pressing of the key may be required. "Servo-grade" clamp-on or compression style couplings are usually the best choice when

you consider stiffness, torque rating, and inertia. Higher stiffness (lb-in/radian) is needed for better response but there is a trade-off between stiffness and the added inertia of the coupling. Concerning the torque rating of the coupling, use a safety factor of 1.25 over the servo's **peak** torque requirement of your application.

[Click here for Available Couplings](#)

Mechanical transmissions

Common mechanical transmissions include leadscrews, rack & pinion mechanisms, conveyors, gears, and timing belts. The use of leadscrew, rack & pinion, or conveyor are common ways to translate the rotary motion of the servo motor into linear motion of the load. Matched gearboxes are available from LS Electric that will work with the LS servo motors. Each gearbox is selected to accept the 300% maximum available torque that could be generated by the motor. Gearboxes are available in 5:1, 10:1, and 20:1 ratios. The use of a speed reducer such as a gearbox or timing belt can be very beneficial as follows:

1. Reduction of reflected load inertia

As a general rule, keep the reflected load inertia as low as possible while using the full range of servo speed. The LS Electric motors can rotate at a rated speed of 3000 rpm (rated torque at rated speed). Their max speed (slightly less available torque) is 3300 rpm. See the speed-torque curves for more information.

Example: A gearbox reduces the motor's required torque by a factor of the gear ratio, and reduces the reflected load inertia by a factor of the gear ratio squared. A 10:1 gearbox reduces output speed to 1/10, increases output torque 10 times, and decreases reflected inertia to 1/100.

However, when investigating the effect of different speed reduction ratios DO NOT forget to include the added inertia of couplings, gearbox, or timing belt pulleys. These added inertias can be significant, and can negate any inertia reduction due to the speed reduction.

2. Low speed and high torque applications

If the application requires low speed and high torque then it is common to introduce a speed reducer so that the servo system can operate over more of the available speed range. This could also have the added benefit of reducing the servo motor torque requirement which could allow you to use a smaller and lower cost servo system. Additional benefits are also possible with reduction in reflected inertia, increased number of motor encoder counts at the load, and increased ability to reject load disturbances due to mechanical advantage of the speed reducer.

3. Space limitations and motor orientation

LS Electric servo motors can be mounted in any orientation, but the shaft seal should not be immersed in oil (open-frame gearbox, etc.). Reducers can possibly allow the use of a smaller motor or allow the motor to be repositioned.



[Here is a link to our Timing Belts and Pulleys](#)

Motor	Brake Motor	Planetary In-Line Gearboxes					
		5:1 Gearbox	10:1 Gearbox	15:1 Gearbox	20:1 Gearbox	25:1 Gearbox	50:1 Gearbox
APMC-FAL01AM8N-8-AD	APMC-FAL01AM8N2-8-AD	PGA050-05A1	PGA050-10A1	PGA050-15A1	<i>n/a</i>	PGA050-25A1	PGD064-50A1
APMC-FBL01AMK-8-AD	APMC-FBL01AMK2-8-AD	96200004	96200005	<i>n/a</i>	96200103	<i>n/a</i>	<i>n/a</i>
APMC-FBL02AMK-8-AD	APMC-FBL02AMK2-8-AD						
APMC-FBL03AMK-8-AD	APMC-FBL03AMK2-8-AD						

Ordering Guide

The following pages are your ordering guide for LS Electric PHOX servo systems. Each system has a torque-speed curve included for reference. This is the fundamental information that you need to select the servo motor and matching drive for your application.

Each system needs:

- Drive and Motor
- Motor Power Cable
- Motor Encoder Cable
- I/O connections (either a 26-pin CN1 cable+terminals kit or a 26-pin flying lead cable (user provides terminal blocks))
- Brake motors require a brake cable.
- STO cable (APCS-PHOX-STOxxA-AD) (optional). An STO connector (PHOX-CON-B) is included with each drive.

PHOX series drives and motors part numbering system

Drives

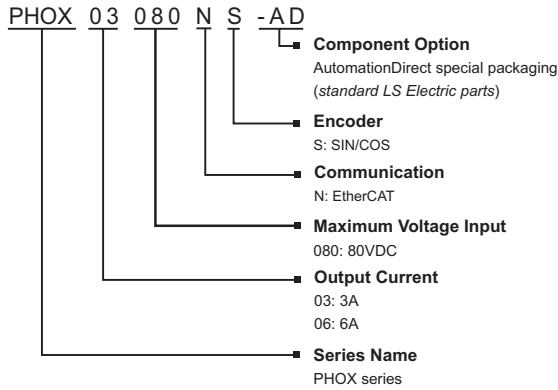

Motors

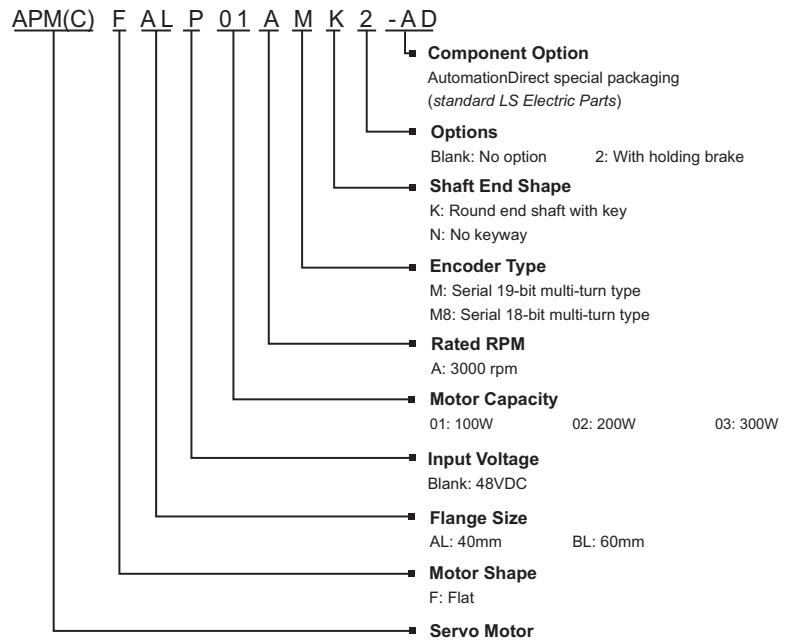

Example of what you will need to build a complete servo system:

Servo Drive + Servo Motor + Motor Power Cable + Motor Encoder Cable + I/O and STO Interface

Completed motor assembly (with optional gearbox)

NOTE: AMPC-FAL/FBL brake equipped motors will also require a separate brake power cable.

NOTE: Required programming software (free download). Use a standard USB-A to USB mini-B cable for connectivity (SV2-PGM-USB15, MOSAIC-CSU, or equivalent)

NOTE: If you need a gear box for your configuration, reference the gearbox chart on the previous page.





PHOX Series Servo Systems

Torque to PHOX System Quick Reference

System Rated Torque (N·m)	System Maximum Torque (N·m)	Suggested Servo Motor	Required Servo Drive
0.32	0.96	APMC-FAL01AM8N-8-AD	PHOX-03-080NS-AD
		APMC-FAL01AM8N2-8-AD	
		APMC-FBL01AMK-8-AD	
		APMC-FBL01AMK2-8-AD	
0.64	1.92	APMC-FBL02AMK-8-AD	PHOX-06-080NS-AD
		APMC-FBL02AMK2-8-AD	
0.95	2.54	APMC-FBL03AMK-8-AD	
		APMC-FBL03AMK2-8-AD	



PHOX Series Servo Systems

PHOX DC servo drive, motor, and cable combinations

xx = Cable length in meters
 BN/EN/PN = Standard cable (not continuous flex)
 BF/EF/PF = Flex-rated cable

AM8N/AMK motors = no brake
 AM8N2/AMK2 motors = mechanical holding brake

48VDC AM8N/AMK Motor Systems

Type	System Torque Chart	PHOX Drive	APM/APMC Motor	Power Cable	Encoder Cable	Brake Cable	I/O Wiring Options
100W Low Inertia System (FAL motor)		PHOX-03-080NS-AD	APMC-FAL01AM8N-8-AD	APCV-PNxxLS-AD	APCV-ENxxES1-AD	n/a	APCS-PHOX-IOTxx-AD (cable and breakout) or APCS-PHOX-IOxxA-AD (connector-to-pigtail cable)
				APCV-PFxxLS-AD	APCV-EFxxES1-AD		
			APMC-FAL01AM8N2-8-AD	APCV-PNxxLS-AD	APCV-ENxxES1-AD	APCV-BNxxQS-AD	
				APCV-PFxxLS-AD	APCV-EFxxES1-AD	APCV-BFxxQS-AD	
100W Low Inertia System (FBL motor)		PHOX-03-080NS-AD	APMC-FBL01AMK-8-AD	APCV-PNxxLS-AD	APCV-ENxxES1-AD	n/a	
				APCV-PFxxLS-AD	APCV-EFxxES1-AD		
			APMC-FBL01AMK2-8-AD	APCV-PNxxLS-AD	APCV-ENxxES1-AD	APCV-BNxxQS-AD	
				APCV-PFxxLS-AD	APCV-EFxxES1-AD	APCV-BFxxQS-AD	
200W Low Inertia System		PHOX-06-080NS-AD	APMC-FBL02AMK-8-AD	APCV-PNxxLS-AD	APCV-ENxxES1-AD	n/a	
				APCV-PFxxLS-AD	APCV-EFxxES1-AD		
			APMC-FBL02AMK2-8-AD	APCV-PNxxLS-AD	APCV-ENxxES1-AD	APCV-BNxxQS-AD	
				APCV-PFxxLS-AD	APCV-EFxxES1-AD	APCV-BFxxQS-AD	
300W Low Inertia System		PHOX-06-080NS-AD	APMC-FBL03AMK-8-AD	APCV-PNxxLS-AD	APCV-ENxxES1-AD	n/a	
				APCV-PFxxLS-AD	APCV-EFxxES1-AD		
			APMC-FBL03AMK2-8-AD	APCV-PNxxLS-AD	APCV-ENxxES1-AD	APCV-BNxxQS-AD	
				APCV-PFxxLS-AD	APCV-EFxxES1-AD	APCV-BFxxQS-AD	

Note: Fxx cables are rated for continuous flexing applications, Nxx cables are not.



PHOX Series Servo Systems

PHOX Servo drive specifications

PHOX Servo Drive Specifications			
Model		<u>PHOX-03-080NS-AD</u>	<u>PHOX-06-080NS-AD</u>
Price		\$434.00	\$454.00
Drawing		PDF	PDF
Power	Input Power	24-80 VDC ¹	
	Rated Current [Amps]	3	6
	Peak Current [Amps]	9A > 1 sec	18A > 1 sec
Supported Encoder Types	Encoder A	Quadrature (Max. 10Mpps after X4) - with and without hall sensors, Differential Serial Encoder (absolute, incremental) - BiSS(B,C), Endat 2.2, Tamagawa Serial, SSI	
	Encoder B ²	Quadrature (Max. 10Mpps after X4) - without hall sensors, Differential Serial Encoder (absolute, incremental) - BiSS(B,C), Endat 2.2, Tamagawa Serial, SSI Analog Encoder - Sinusoidal (1Vpp), Analog hall (Sin/Cos) - Resolver (Optional)	
	Output Type	AO (+/-), BO (+/-), ZO (+/-), Line Driver output max 6.4 Mpps	
Control Performance	Speed Control Range	Maximum 1:5000	
	Frequency Response	Maximum 1kHz or above (when using 19-bit serial encoder)	
	Speed Variation Ratio	±0.01 % or lower (when load changes between 0 and 100%) ±0.1 % or lower (temperature 25±10°C)	
	Accel/Decel Time	Within ±1%	
	Input Frequency	4Mpps, line drive	
	Input Pulse Method	Symbol+Pulse series, CW+CCW, Phase A/B	
Recommended Fuse		PHOX-03: 5A, PHOX-06: 10A	
EtherCAT® Specification	Communication Standard	FoE (firmware download) EoE (parameter setting by UDP, tuning, secondary function, parameter copy) CoE (IEC 61158 Type 12, IEC 61800-7 CIA 402 Drive profile)	
	Physical Layer	100BASE-TX (IEEE802.3)	
	Connector	RJ45 x 2	
	Communication Distance	Maximum distance between nodes (100m)	
	DC (Distributed Clock)	Synchronization by DC mode, minimum DC cycle: 250 (µs)	
	LED Display	LinkAct IN, LinkAct OUT, RUN, ERR	
	CiA 402 Drive Profile	Profile Position Mode, Profile Velocity Mode, Profile Torque Mode, Cycle Synchronous Position Mode, Cyclic Synchronous Velocity Mode, Cyclic Synchronous Torque Mode, Homing Mode	
Digital I/O Specifications	Digital Input	4 discrete inputs (selectable). Each input can trigger one of the following 33 functions (*=default): (*POT, *NOT, *HOME, *STOP, PCON, GAIN2, P_CL, N_CL, PROBE1P, ROBE2, EMG, A_RST, SV_ON, START, PAUSE, REGT, HSTART, ISELO-5, ABS_RQ, JSTART, JDIR, PCLR, AOV, INHIB, SPD1, SPD2, SPD3, MODE)	
	Digital Output	4 discrete outputs (selectable). Each output can be configured to indicate one of the following 33 functions: (*=default) (*BRAKE, *ALARM, *READY, *ZSPD, INPOS1, INPOS2, TLMT, VLMT, INSPD, WARN, TGON, ORG, EOS, IOUT0, IOUT1, IOUT2, IOUT3, IOUT4, IOUT5)	
Analog I/O	Analog Input	One input voltage channel (allocatable), range: ±5V differential Input can be configured to indicate one of the following 4 functions (not all functions available in all Control Modes): (Speed Override, Speed Command, Torque Command, Torque Limit)	
	Analog Output	2 analog output channels (selectable), ±10V Each output can be configured to indicate one of following 24 functions: (Speed Feedback, Speed Command, Speed Error, Torque Feedback, Torque Command, Position Error, Accumulated Operation Overload, DC Link Voltage, Encoder Single-Turn Data, Inertia Ratio, Following Error Actual Value, Drive Temperature 1, Drive Temperature 2, Encoder Temperature, Hall Sensor Signal, U-phase Current, V-phase Current, W-Phase Current, Position Actual value, Position Demand Value, Position Command Speed, Hall U Value, Hall V Value, Hall W Value)	
Continued on next page			

1 - It is possible to drive with a voltage of less than 48VDC input power, but the actual maximum speed (while loaded) may be slower than the rated speed and the motor specifications cannot be guaranteed. We recommend using a minimum of 48VDC as the input power if possible. Using an input higher than 48VDC does not result in higher performance.

2 - Available when full-closed loop or dual feedback control functions are applied.



PHOX Series Servo Systems

PHOX Servo drive specifications, *continued*

PHOX Servo Drive Specifications, <i>continued</i>		
<i>Continued from previous page</i>		
<i>Model</i>	<i>All PHOX Series Drives</i>	
<i>Safety Function</i>	2 input channels (STO1, STO2)	
<i>USB Communication</i>	<i>Function</i>	Firmware download, parameter setting, tuning, auxiliary function, parameter copy
	<i>Communication Standard</i>	Complies with USB 2.0 Full-speed specifications
	<i>Connect</i>	PC or USB storage media
<i>Internal Function</i>	<i>Self-setting Function</i>	Drive node address can be set using dip switch
	<i>Additional Function</i>	Gain tuning, alarm history, JOG operation, origin search
	<i>Protection Function</i>	Overcurrent, overload, excessive current limit, overheat, overvoltage, undervoltage, overspeed, encoder error, position following error, current sensing error
<i>Operation Environment</i>	<i>Operating Temperature</i>	0 to 50 °C (32 to 122 °F)
	<i>Storage Temperature</i>	-20 to 65 °C (-4 to 149 °F)
	<i>Operating Humidity</i>	Below 80% relative humidity
	<i>Storage Humidity</i>	Below 90% relative humidity (non-condensing)
	<i>Vibration</i>	19.6 m/s ² or less
	<i>Environment</i>	Keep indoors, avoid corrosive/flammable gas or liquid, and electrically conductive dust
<i>Approvals</i>	CE, REACH, cUR _{us}	

PHOX Drive Standard Installation

PHOX Drive Installation Spacing

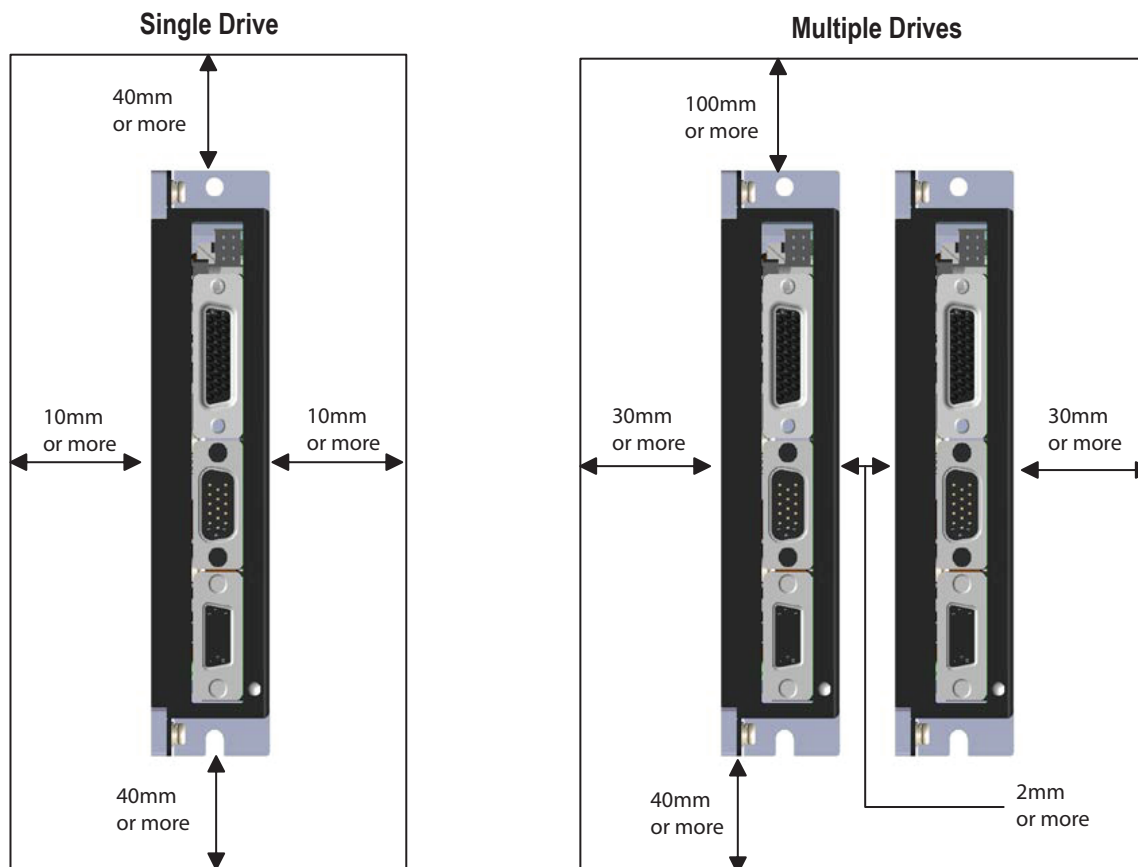

PHOX Drive Installation Concerns:

- Install external regenerative resistors so that any heat generated does not affect the drive.
- Vertical installation only. For proper heat dissipation, ensure the back of the drive makes good contact with the subpanel.
- Protect the drive from metal chips and other falling debris during control panel assembly.
- Make sure that oil, water, or metal dust do not enter the drive.
- Protect the control panel by using an air purge system when installing it in any area where there are harmful gases or dust.

PHOX Drive Wiring

PHOX Power Supply Wiring

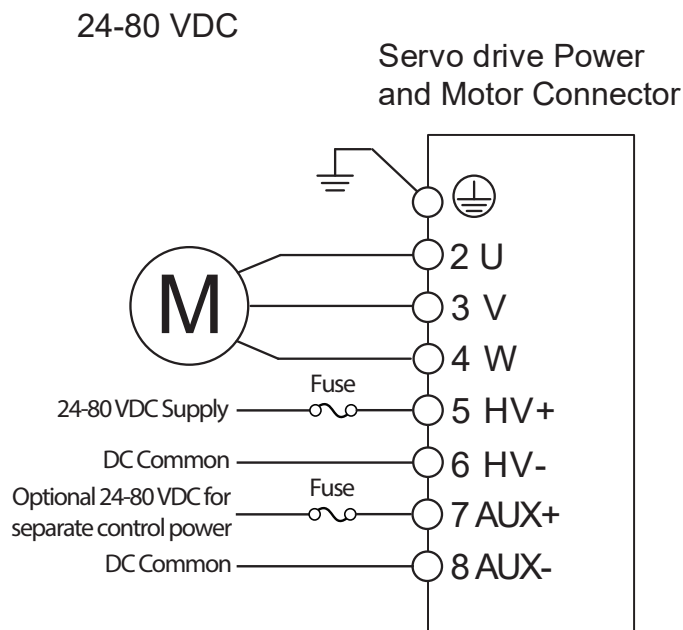

PHOX Brake Wiring (dedicated brake connector)

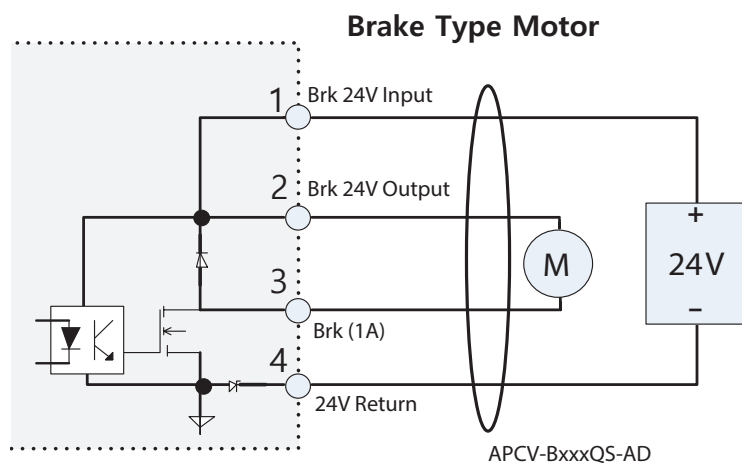

Notes:

- See available brake cables later in this section (cables contain wiring for 24VDC supply to the drive and brake power output to the motor brake).
- Or use the crimp pins and connector that ship with each drive.

PHOX Drive Wiring, *continued*

PHOX STO Wiring (*dedicated connector*)

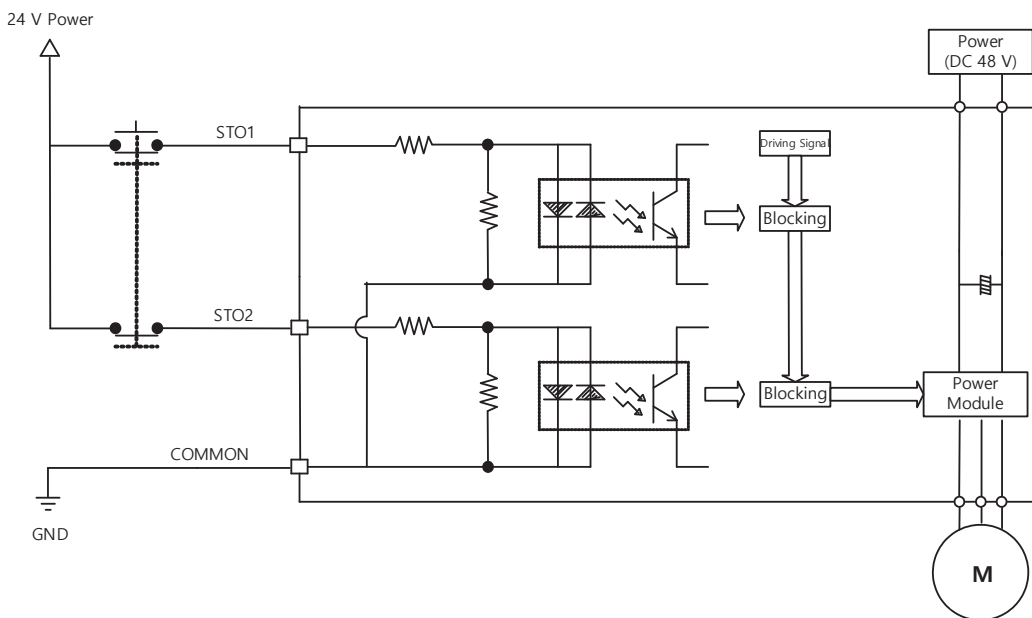

Notes:

- See available STO cables later in this section or use the crimp pins and connector that ship with each drive.

STO Bypass

To bypass STO (during commissioning/testing) connect the STO terminals as shown. Never connect anything else to V+ or V-.

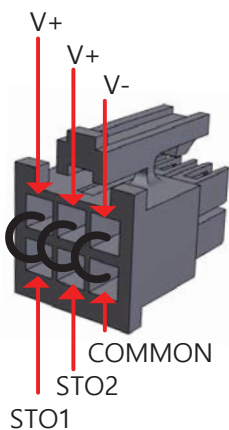

PHOX Drive Wiring, *continued*

PHOX Input/Output Signal Wiring (26-pin D-sub connector)

Note: Use the dedicated brake connector output to control the brake instead of DO1. This saves the use of a configurable digital output and eliminates the need for an interposing relay (relay is only required if using DO1 to operate a motor holding brake)

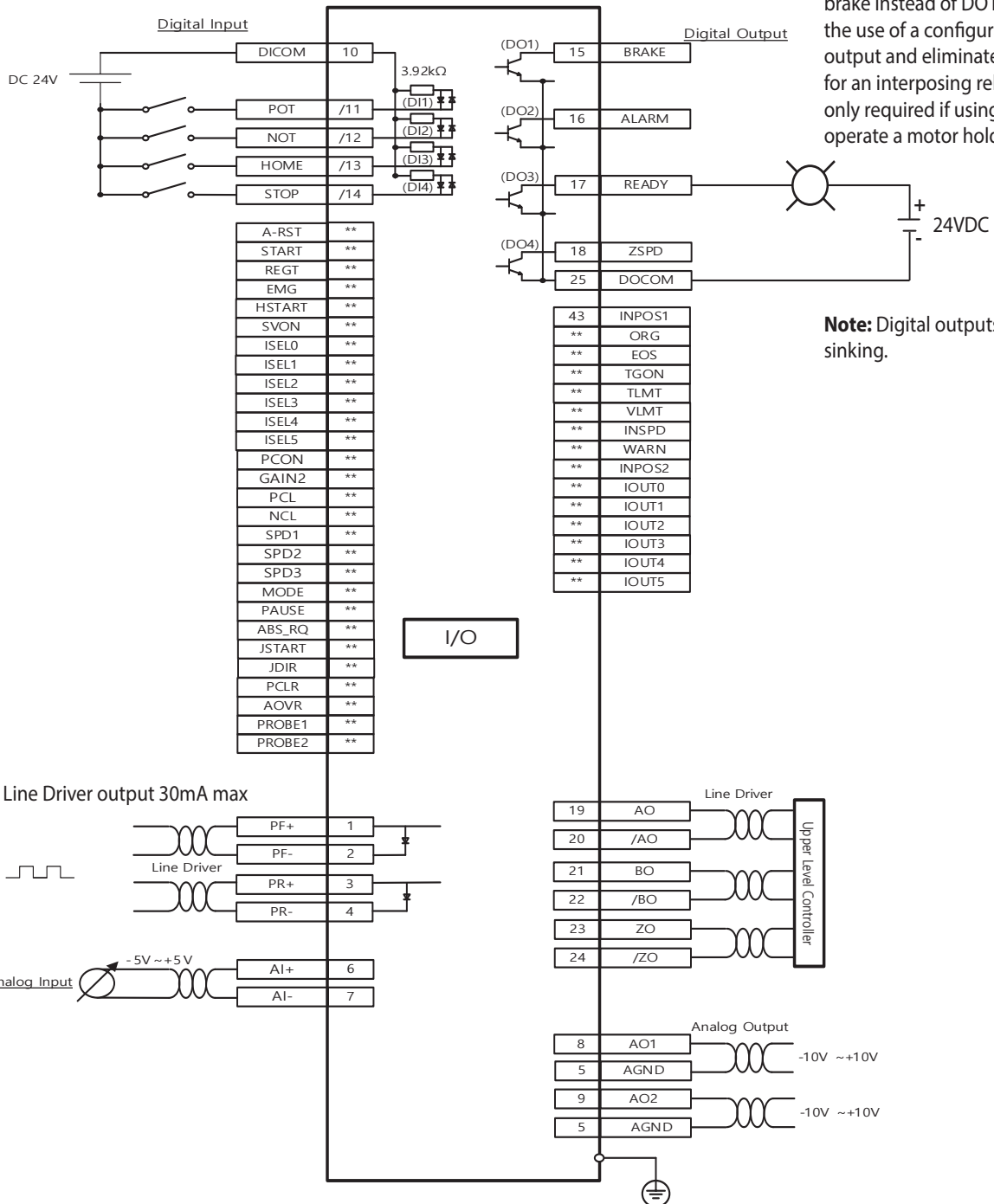

Note: Line Driver output 30mA max



PHOX Series Servo Systems

Motor Specifications

PHOX Motor Specifications								
Model	APMC-FAL01AM8N-8-AD	APMC-FAL01AM8M2-8-AD	APMC-FBL01AMK-8-AD	APMC-FBL01AMK2-8-AD	APMC-FBL02AMK-8-AD	APMC-FBL02AMK2-8-AD	APMC-FBL03AMK-8-AD	APMC-FBL03AMK2-8-AD
Price	\$267.00	\$460.00	\$210.00	\$386.00	\$248.00	\$434.00	\$305.00	\$495.00
Drawing	PDF	PDF	PDF	PDF	PDF	PDF	PDF	PDF
Input Voltage	24-80 VDC							
Drive Compatibility	PHOX-03-080NS-AD				PHOX-06-080NS-AD			
Integrated Brake	N	Y	N	Y	N	Y	N	Y
Flange Size (mm)	40			60				
Rated Power [W]	100W		100W		200W		300W	
Rated Torque [N·m] ^{Note 1}	0.32		0.32		0.64		0.95	
Max. Torque [N·m]	0.96		0.96		1.92		2.54	
Rated Speed [rpm]	3000							
Max. Speed [rpm]	3300							
Rated current [Amps] rms	2.71		2.5		5.54		6.79	
Max. Instantaneous Current [Amps] rms	8.13		7.50		16.62		18.0	
Rated Power Rate [kW/s]	24.24		11.13		27.57		36.81	
Rotor Inertia [x10 ⁻⁴ kg m ²]	0.042		0.091		0.147		0.248	
Allowable Load Inertia Ratio	30 times motor inertia			20 times motor inertia				
Speed/Position Detector	Serial multi-turn built-in encoder (18-bit)			Serial multi-turn built-in encoder (19-bit)				
Protection	Fully enclosed self cooling IP67 ¹							
Rated Time	Continuous							
Ambient Temperature	Operating		0 to 40°C (32 to 104°F)					
	Storage		-10 to 60°C (14 to 140°F)					
Ambient Humidity	Operating		Below 80% relative humidity					
	Storage		Below 90% relative humidity (non-condensing)					
Atmosphere	Avoid direct sunlight and corrosive/flammable gas or liquid							
Vibration Resistance	Vibration acceleration 49m/s ² (5G)							
Weight [kg]	0.45	0.45	0.56	0.56	0.74	0.74	1.06	1.06

Note 1—Axis penetration not included. The IP rating for attached reducers is not guaranteed. Cables may not qualify marked IP rating if bent beyond designated specifications. Use specific cables for IP rating qualification.

Accessories

CN1 Accessories

For PHOX series drives, two methods are available for creating I/O connections.

Option 1:

Terminal blocks + cables:

- [APCS-PHOX-IOT-AD](#)
- [APCS-PHOX-IOT01-AD](#)
- [APCS-PHOX-IOT015-AD](#)
- [APCS-PHOX-IOT02-AD](#)

APCS-PHOX-IOT terminals ship with a universal labeling strip (A1-A13, B1-B13). A labeling template with designations specifically for the PHOX drive can be downloaded from any of the drive pages or the terminal block page (www.automationdirect.com/pn/apcs-phox-iot-ad).



[APCS-PHOX-IOT01-AD](#)

Option 2:

Flying lead cables:

- [APCS-PHOX-IO01A-AD](#)
- [APCS-PHOX-IO02A-AD](#)
- [APCS-PHOX-IO03A-AD](#)



[APCS-PHOX-IO03A-AD](#)

Part Number	Price	Description	Cable Length	Drawing	Compatible Drives
APCS-PHOX-IOT-AD	\$126.00	LS Electric CN1 feedthrough terminal block, 26-pole, DIN rail mount. For use with all LS Electric PHOX series drives. Control cable included.	0.5 m [1.6 ft]	PDF	All PHOX drives
APCS-PHOX-IOT01-AD	\$131.00		1.0 m [3.2 ft]	PDF	
APCS-PHOX-IOT015-AD	\$136.00		1.5 m [4.9 ft]	PDF	
APCS-PHOX-IOT02-AD	\$139.00		2.0 m [6.5 ft]	PDF	
APCS-PHOX-IO01A-AD	\$83.00	LS Electric control cable, 26-pin connector to pigtail.	1.0 m [3.2 ft]	PDF	
APCS-PHOX-IO02A-AD	\$87.00		2.0 m [6.5 ft]	PDF	
APCS-PHOX-IO03A-AD	\$91.00		3.0 m [9.8 ft]	PDF	

Accessories

PHOX Terminal Assignment Table



CAUTION: This terminal assignment table is for use with PHOX drives ONLY. Using this table with non-PHOX series drives could damage your equipment as terminal assignments are different for each drive series.

APCS-PHOX-IOTxx-AD

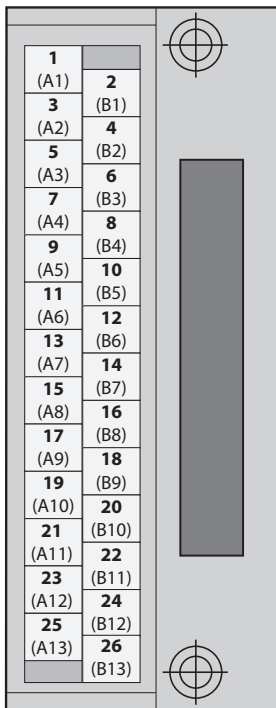

You can download a printable terminal label at <https://www.automationdirect.com/pn/apcs-phox-iot-ad>

PHOX Drive Terminal Assignments

Terminal	Drive I/O Pin/Wire #	Description	Wire Color	Number of Stripes
A1	1	PF+	Orange/Black Stripe	1
B1	2	PF-	Orange/Red Stripe	1
A2	3	PR+	Orange/Black Stripe	2
B2	4	PR-	Orange/Red Stripe	2
A3	5	AGND	Orange/Black Stripe	3
B3	6	AI+	Orange/Red Stripe	3
A4	7	AI-	Orange/Black Stripe	4
B4	8	AMON1	Orange/Red Stripe	4
A5	9	AMON2	Orange/Black Stripe	5
B5	10	DICOM Input Power	Orange/Red Stripe	5
A6	11	DI1	Yellow/Black Stripe	1
B6	12	DI2	Yellow/Red Stripe	1
A7	13	DI3	Yellow/Black Stripe	2
B7	14	DI4	Yellow/Red Stripe	2
A8	15	DO1	Yellow/Black Stripe	3
B8	16	DO2	Yellow/Red Stripe	3
A9	17	DO3	Yellow/Black Stripe	4
B9	18	DO4	Yellow/Red Stripe	4
A10	19	AO	Yellow/Black Stripe	5
B10	20	/AO	Yellow/Red Stripe	5
A11	21	BO	White/Black Stripe	1
B11	22	/BO	White/Red Stripe	1
A12	23	ZO	White/Black Stripe	2
B12	24	/ZO	White/Red Stripe	2
A13	25	DOCOM Common GND	White/Black Stripe	3
B13	26	AGND	White/Red Stripe	3

Accessories, *continued*

NOTE: These parts available for sale to North American locations only

PHOX System STO Cables

Use these pre-made factory cables to easily connect the drive STO connector to a safety relay.

Part Number	Price	Length	Description	Drawing	Compatible Motors
APCS-PHOX-STO03A-AD	\$23.00	0.3 m [1ft]	LS Electric STO cable, 6-pin connector to pigtail,	PDF	All PHOX series drives
APCS-PHOX-STO10A-AD	\$25.00	1m [3.2 ft]		PDF	
APCS-PHOX-STO30A-AD	\$28.00	3m [9.8 ft]		PDF	



APCS-PHOX-STO series cable

Accessories, continued

NOTE: These parts available for sale to North American locations only

PHOX System Motor Encoder Cables

Part Number	Price	Flex Rated	Length	Gauge	Drawing	Compatible Motors
APCV-EN03ES1-AD	\$107.00	N	3m [9.8 ft]	24AWG	PDF	All PHOX APMC motors
APCV-EN05ES1-AD	\$114.00		5m [16.4 ft]		PDF	
APCV-EN10ES1-AD	\$127.00		10m [32.8 ft]		PDF	
APCV-EN20ES1-AD	\$159.00		20m [65.6 ft]		PDF	
APCV-EF03ES1-AD	\$117.00	Y	3m [9.8 ft]		PDF	
APCV-EF05ES1-AD	\$127.00		5m [16.4 ft]		PDF	
APCV-EF10ES1-AD	\$159.00		10m [32.8 ft]		PDF	
APCV-EF20ES1-AD	\$221.00		20m [65.6 ft]		PDF	

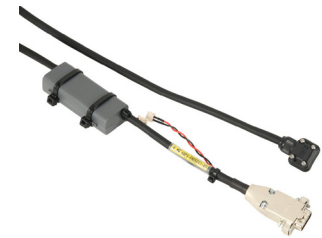

APCV-EN series encoder cable

PHOX System Motor Power Cables

Part Number	Price	Flex Rated	Length	Gauge	Drawing	Compatible Motors
APCV-PN03LS-AD	\$48.00	N	3m [9.8 ft]	24AWG	PDF	All PHOX APMC motors
APCV-PN05LS-AD	\$53.00		5m [16.4 ft]		PDF	
APCV-PN10LS-AD	\$67.00		10m [32.8 ft]		PDF	
APCV-PN20LS-AD	\$94.00		20m [65.6 ft]		PDF	
APCV-PF03LS-AD	\$56.00	Y	3m [9.8 ft]		PDF	
APCV-PF05LS-AD	\$67.00		5m [16.4 ft]		PDF	
APCV-PF10LS-AD	\$95.00		10m [32.8 ft]		PDF	
APCV-PF20LS-AD	\$147.00		20m [65.6 ft]		PDF	



APCV-PN series power cable

PHOX System Motor Brake Cables

Part Number	Price	Flex Rated	Length	Gauge	Drawing	Compatible Motors
APCV-BN03QS-AD	\$48.00	N	3m [9.8 ft]	24AWG	PDF	All PHOX APMC motors
APCV-BN05QS-AD	\$52.00		5m [16.4 ft]		PDF	
APCV-BN10QS-AD	\$57.00		10m [32.8 ft]		PDF	
APCV-BN20QS-AD	\$72.00		20m [65.6 ft]		PDF	
APCV-BF03QS-AD	\$53.00	Y	3m [9.8 ft]		PDF	
APCV-BF05QS-AD	\$58.00		5m [16.4 ft]		PDF	
APCV-BF10QS-AD	\$73.00		10m [32.8 ft]		PDF	
APCV-BF20QS-AD	\$102.00		20m [65.6 ft]		PDF	







APCV-BN series brake cable

Note: Each brake cable consists of 4 wires: 24VDC and Common (input to the drive), and BRK+ and BRK- output to the motor brake.

Accessories, continued

PHOX Drive Replacement Connectors

Part Number	Price	Description	Compatible Drives	Image
<u>PHOX-CON-A</u>	\$15.00	AutomationDirect drive power connector, replacement, 8-pin. For use with all LS Electric PHOX series drives.	All LS Electric PHOX Drives	
<u>PHOX-CON-B</u>	\$5.00	AutomationDirect drive STO connector, replacement, 6-pin. For use with all LS Electric PHOX series drives. Requires PHOX-CON-D drive STO/brake crimp pins.		
<u>PHOX-CON-C</u>	\$5.00	AutomationDirect drive brake connector, replacement, 4-pin. For use with all LS Electric PHOX series drives. Requires PHOX-CON-D drive STO/brake crimp pins.		
<u>PHOX-CON-D</u>	\$9.00	AutomationDirect drive STO/brake crimp pins, replacement. Package of 10. For use with all LS Electric PHOX series drives.		
<u>PHOX-CON-E</u>	\$10.00	AutomationDirect drive encoder connector, 15-pin. For use with all LS Electric PHOX series drives. PHOX-CON-E gender changer allows easy wiring of Encoder Port B to an external encoder using ZL-HD15M-CBL-DB15F (with ZIPlink ZL-RTB-DB15 breakout module) or ZL-HD15M-CBL-2P HD15 (with flying leads).		



iX7NH Series Servo Systems

Drive features

- Power: 400W–3.5 kW three-phase 230VAC
400W–750W single-phase 230VAC capable
400W 110VAC capable
- Fully digital control with up to 1kHz velocity loop response
- Easy setup and diagnostics with Drive CM PC-based software or with the built-in webserver
- Field upgradeable firmware ensures the drive can always be upgraded to the latest operating system
- Capable of both EtherCAT® and Modbus TCP control. Uses XBF-PN04B/ XBF-PN08B EtherCAT® PLC modules for EtherCAT® operation and final commissioning. For Modbus TCP operation and final commissioning, use any Modbus TCP Client (Productivity, BRX, Click, etc.).
- Command options over EtherCAT® control and Modbus TCP include:

Command Option	EtherCAT® Control	Modbus TCP Control
Position Mode (PP)		
Homing Mode (HM)		
Velocity Mode (PV)		
Torque Mode (PT)		
Cyclic Synchronous Position Mode (CSP)		
Cyclic Synchronous Velocity Mode (CSV)		
Cyclic Synchronous Torque Mode (CST)		

- ±10V Analog Torque Limit (not torque control)
- The 1 kHz bandwidth allows for high-level automatic tuning. Several modes of tuning are available including Off-Line Auto Tuning (the drive initiates its own move commands while Auto tuning), On-Line Auto Tuning (an external controller sends the move commands while the drive Auto tunes), and Manual Tuning (all tuning values are adjusted by the user).
- (6) Optically isolated configurable digital inputs and (3) user configurable outputs, (1) torque limit analog input. Two configurable analog outputs for monitoring various servo parameters (actual speed, torque, current, position, etc.)
- Advanced Scope feature that can monitor a variety of command and

Tuning Technology

The iX7NH drive closes the loop on current, velocity, and position (depending on control mode selection). The 1kHz bandwidth in the drive assures precise speed and current control and easy tuning. Proportional gain, integral gain and compensation, feed forward compensation, command low pass filter, and four (4) notch filters for resonance suppression are available. Auto Tuning has been greatly improved and can tune motors up to 20:1 inertia mismatch.

There is an inertia estimation function that analyzes the motor and load to measure how much inertia is coupled to the motor.

The drive has several tuning methods available:

- Online Auto Tuning—the drive can either tune the load live while an external controller moves the load to different positions or using the drive's internal tuning motion profile.
- Offline Auto Tuning—the drive tunes the load using the drive's internal tuning motion profile.
- Manual Tuning—all parameters are available to give power users the ultimate flexibility to tune their systems.

EtherCAT®
Modbus TCP



status signals, including output speed, torque, power, etc.

- Future proof your system - use Modbus TCP now and convert to EtherCAT® control in the future.

Motor features

- Low and Medium inertia motors available:
 - Low: 100W, 200W, 400W, 750W, 1kW, and 1.5 kW; @5000rpm
 - Medium: 1.6 kW, 2.2 kW, and 3.5 kW; @3000rpm
- Permanent magnet 3-phase synchronous motor
- Keyed drive shafts support clamp-on style couplings or key-style couplings
- Integrated multi-turn absolute encoder with 19-bit resolution (524,288 pulses per revolution)
- Optional 24 VDC spring-set holding brakes (AMK2 and DMK2 motors)
- Standard hook-up cables for motor power, encoder, and brake (separate brake cable for FBL/FCL brake motors)
- Motor cables available in standard or flex-rated lengths of 3, 5, 10, and 20m
- Standard 20-pin DIN-rail mounted break-out kit for the drive's CN1 connector (with screw terminal connections), or 20-pin cables with flying leads

Note: These parts available for sale to North American locations only.

Control Modes

When connected to an EtherCAT® Master, the iX7NH drive can run in Cyclic Synchronous Modes (Position, Velocity, Torque) where the Master controller sends an updated setpoint every EtherCAT® cycle (~1millisecond). In these modes, the upper controller plans the motion path.

The drive can also work in Profile Modes (Position, Velocity, Torque) where the Master Controller sends one setpoint for each move. In these cases, the drive's accel, decel, and max speed settings determine the motion path planning. The drive also has 21 different homing modes to accommodate most applications.

When connected to a Modbus TCP client, the drive can operate in Profile Modes (Position, Velocity, and Torque) and in Homing Mode. Because Modbus TCP is not deterministic, servos controlled by ModTCP typically aren't operated in Cyclic Synchronous modes.

Optional Holding Brake

Each servo motor can be ordered with an optional 24VDC spring-set holding brake that holds the motor in place when power is removed.

LS Electric MSS Series In-Line Planetary Precision Gearboxes for Servo Motors

Need more torque from the motor? Have an inertia balancing issue in your design? The LS Electric MSS series gearboxes easily mate to FBL/FCL/FE/FF motors. Everything you need for mounting is included!



- Three gear ratios available (5:1, 10:1, 20:1)
- Mounting hardware included for attaching to FBL/FCL/FE/FF motors.
- Industry-standard mounting dimensions
- Thread-in mounting style
- Very low backlash: 7 arc-min single stage (5:1 and 10:1 ratios), 9 arc-min two-stage (20:1 ratios*).
- 1-year warranty

Servo drive overview

DC Bus Charge LED

Visual indication of the drive's DC bus voltage level. Do not work on the drive until the Charge LED is OFF.

Motor Power Terminal

Incoming single or three phase 200-230 VAC (-15% to +10%, 50/60Hz)

DC Reactor Connectors

Regenerative Resistor Terminal

Connection for optional external braking resistor

Control Power Terminal

Incoming single phase 200-230 VAC (-15% to +10%, 50/60Hz)

Motor Output Terminal

Output power to the servo motor. LS motor power cables available in 3, 5, 10, and 20 meter lengths in standard and flexing cables.

Model Number

Clearly displayed on bottom of drive face for easy identification.

LED Display

The 5-digit display is used to indicate servo status and alarm.

2 Rotary DIPswitch

Sets EtherCAT® Node ID from 0 to 97. Setting to 99 enables Modbus TCP with built-in webserver, while setting to 98 enables Modbus TCP w/o webserver.*

Analog Connector

4-pin analog monitoring connector (two +/- 10V analog outputs). See L7P-CON-F and L7P-CON-G for optional connectors.

Status LED

Indicates current state of EtherCAT® communication.

USB Connector

Used by Drive CM software for servo configuration. Connect with a standard USB A to USB mini-B cable (SV2-PGM-USB15, MOSAIC-CSU, or similar). Use USB OTG adapter cable (USB A Female to Mini USB B) if needed)

Firmware Upgrade: Use Drive CM software or attach a USB thumb drive with the new FW and update using USB On the Go (no PC required). See the UM for details.

EtherCAT® Com Ports

(ECAT IN, ECAT OUT). Use ECAT IN port (only) if using Modbus TCP.

Safe Torque Off Connector (STO)

Input/Output Connector (I/O)

20-pin CN1 connector for drive I/O. Signals include high speed pulse inputs, 6 digital inputs, 3 digital outputs, 1 analog input (torque limit), and scalable encoder output.

Encoder Connector

14-pin CN2 connector for the motor encoder. LS Encoder cables available in 3, 5, 10, and 20 meter lengths in standard and flexing cables.

* Node 98 functionality available in firmware 1.15 and above.

The LS Electric iX7NH servo drives are fully digital and include over 300 parameters to configure the drive for almost any application. For convenience, the parameters are grouped into several categories including:

- Basic parameters
- Gain parameters
- I/O parameters
- Velocity parameters
- Misc. parameters
- Monitor parameters

All parameters have commonly used default values which allow you to operate the iX7NH drive "out-of-the-box". The drive auto-detects the LS servo motor (through the serial encoder) and sets up the default gains and limits based on the connected motor.

The drive can still be easily configured to your specific application, however. The Drive CM configuration software has a built-in Setup Wizard that will guide you through all the basic setup parameters. The Setup Wizard will quickly and easily get your application started – from setting up the I/O to determining the appropriate homing sequence. When using ModTCP (Node 99) drive configuration can also be accomplished via a built-in webserver. The webserver is non-secure (does not use https), but the webserver function can be completely disabled by setting the Node ID DIP switches to 98.

Using XGB XBF-PN04B or XBF-PN08B EtherCAT® motion modules, you can also configure your drive from the XG5000 interface. See the Interactive PLC Guide for videos on how to commission and program the PLC/servo system.

After configuration is complete, the Auto Tune features of the drive will get your application tuned for optimal responsiveness and performance.

How to select and apply iX7NH systems

The primary purpose of the AC servo system is to precisely control the motion of the load. The most fundamental considerations in selecting the servo system are “reflected” load inertia, servo system maximum speed requirement, servo system continuous torque requirement, and servo system peak torque requirement. In a retrofit application, select the largest torque servo system that most closely matches these parameters for the system being replaced. In a new application, these parameters should be determined through calculation and/or

measurement. The Drive CM software has the ability to measure the load (reflected) inertia and accurately measure the motor torque output.

AutomationDirect has teamed with Copperhill Technologies to provide free servo-sizing software. “VisualSizer-SureServo” software will assist in determining the correct motor and drive for your application by calculating the reflected load inertia and required speed and torque based on the load configuration. “VisualSizer-SureServo” software can be downloaded from <https://support.automationdirect.com/products/lselectric.html>.

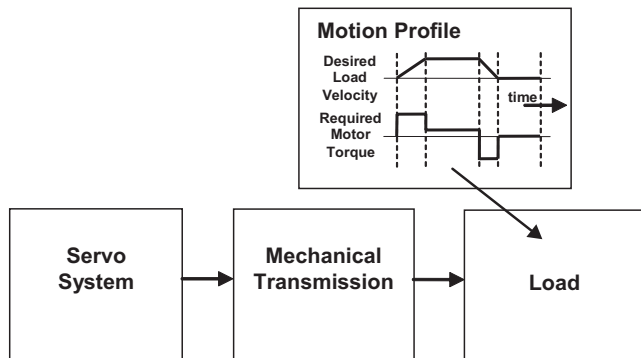

1. “Reflected” load inertia

The inertia of everything attached to the servo motor driveshaft needs to be considered and the total “reflected” inertia needs to be determined. This means that all elements of any mechanical transmission and load inertia need to be translated into an equivalent inertia as if attached directly to the motor driveshaft. The ratio of “reflected” load inertia to motor inertia needs to be carefully considered when selecting the servo system.

In general, applications that need high response or bandwidth

will benefit from keeping the ratio of load inertia to motor inertia as low as possible and ideally under 10:1. iX7NH Auto Tuning will still tune a system with very high response, up to 20:1 inertia mismatch. Higher system ratios can be implemented, but corresponding lower bandwidth or responsiveness must be accepted. The servo response including the attached load inertia is determined by the servo tuning. The iX7NH servo systems may be tuned automatically by the software/drive or manually by the user.

2. Torque and speed

With knowledge of the motion profile and any mechanical transmission between the motor and load, calculations can be made to determine the required servo motor continuous torque, peak torque, and maximum motor speed. The required amount of continuous torque must fall inside the continuous operating region of the system torque-speed curve (you can check the continuous torque at the average speed of the motion profile). The required amount of peak torque must also fall within the servo system’s intermittent operating region of the system torque-speed curve (you need to check this value at the required maximum speed or torque). If you have an iX7NH system, these values are easily captured and recorded with the Scope feature built into the Drive CM software. If you are designing the system from scratch, use VisualSizer to define the system and calculate expected inertia and required power.

Compare the application’s Continuous and Intermittent torque requirements to the torque-speed curves found in Chapter 11.3 of the iX7NH User Manual or in the system torque charts found on “iX7NH AC servo drive, motor, and cable combinations” on page tSRV-28.

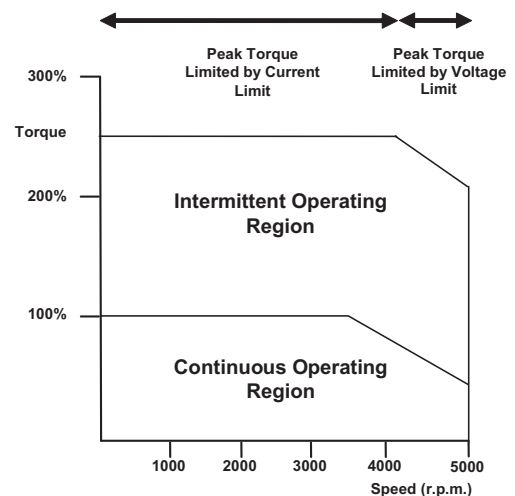

Application tip - coupling considerations

The LS Electric FBL/FCL motors have keyed shafts that can be used with keyed couplings or with clamp-on or compression style couplings. For standard keyed couplings, the servo key must be "fitted" into the keyway for optimum performance and longevity. Some minor filing and pressing of the key may be required. "Servo-grade" clamp-on or compression style couplings

are usually the best choice when you consider stiffness, torque rating, and inertia. Higher stiffness (lb-in/radian) is needed for better response but there is a trade-off between stiffness and the added inertia of the coupling. Concerning the torque rating of the coupling, use a safety factor of 1.25 over the servo's **peak** torque requirement of your application.

[Click here for Available Couplings](#)

Mechanical transmissions

Common mechanical transmissions include leadscrews, rack & pinion mechanisms, conveyors, gears, and timing belts. The use of leadscrew, rack & pinion, or conveyor are common ways to translate the rotary motion of the servo motor into linear motion of the load. Matched gearboxes are available from LS Electric that will work with the LS servo motors. Each gearbox is selected to accept the 300% maximum available torque that could be generated by the motor. Gearboxes are available in 5:1, 10:1, and 20:1 ratios. The use of a speed reducer such as a gearbox or timing belt can be very beneficial as follows:

1. Reduction of reflected load inertia

As a general rule, keep the reflected load inertia as low as possible while using the full range of servo speed. The LS Electric motors can rotate at a rated speed of 2000 or 3000 rpm (rated torque at rated speed). Their max speed (slightly less available torque) is 3000 or 5000 rpm. See the speed-torque curves for more information.

Example: A gearbox reduces the motor's required torque by a factor of the gear ratio, and reduces the reflected load inertia by a factor of the gear ratio squared. A 10:1 gearbox reduces output speed to 1/10, increases output torque 10 times, and decreases reflected inertia to 1/100.

However, when investigating the effect of different speed reduction ratios DO NOT forget to include the added inertia of couplings, gearbox, or timing belt pulleys. These added inertias can be significant, and can negate any inertia reduction due to the speed reduction.

[Here is a link to our Timing Belts and Pulleys](#)

2. Low speed and high torque applications

If the application requires low speed and high torque then it is common to introduce a speed reducer so that the servo system can operate over more of the available speed range. This could also have the added benefit of reducing the servo motor torque requirement which could allow you to use a smaller and lower cost servo system. Additional benefits are also possible with reduction in reflected inertia, increased number of motor encoder counts at the load, and increased ability to reject load disturbances due to mechanical advantage of the speed reducer.

3. Space limitations and motor orientation

LS Electric servo motors can be mounted in any orientation, but the shaft seal should not be immersed in oil (open-frame gearbox, etc.). Reducers can possibly allow the use of a smaller motor or allow the motor to be repositioned.



Motor	Brake Motor	LS Electric MSS Planetary In-Line Gearboxes		
		5:1 Gearbox	10:1 Gearbox	20:1 Gearbox
APMC-FBL01AMK-AD	APMC-FBL01AMK2-AD	96200004	96200005	96200103
APMC-FBL02AMK-AD	APMC-FBL02AMK2-AD			
APMC-FBL04AMK-AD	APMC-FBL04AMK2-AD			
APMC-FCL08AMK-AD	APMC-FCL08AMK2-AD	96200007	96200008	96200257
APMC-FCL10AMK-AD	APMC-FCL10AMK2-AD			
APM-FE15AMK-AD	APM-FE15AMK2-AD	96200373	96200378	96200393
APM-FE16DMK-AD	APM-FE16DMK2-AD	96200459	96200464	96200479
APM-FE22DMK-AD	APM-FE22DMK2-AD	96200010	96200011	96200445
APM-FF35DMK-AD	APM-FF35DMK2-AD	96200013	96200014	96200701

Ordering Guide

The following pages are your ordering guide for LS Electric iX7NH servo systems. Each system has a torque-speed curve included for reference. This is the fundamental information that you need to select the servo motor and matching drive for your application.

Each system needs:

- Drive and Motor
- Motor Power Cable
- Motor Encoder Cable
- I/O connections (either a 20-pin CN1 cable+terminals kit or a 20-pin flying lead cable (user provides terminal blocks))
- FBL/FCL brake motors require a brake cable. FE/FF brake motors have brake wiring included in the power cable.
- STO cable (APCS-STOxxA-AD) or STO bypass plug (APCS-CN6K-AD). An STO bypass plug is included with each drive.

iX7NH series drives and motors part numbering system

Drives

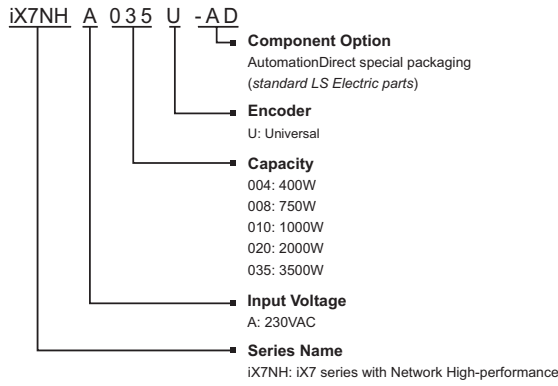

Motors

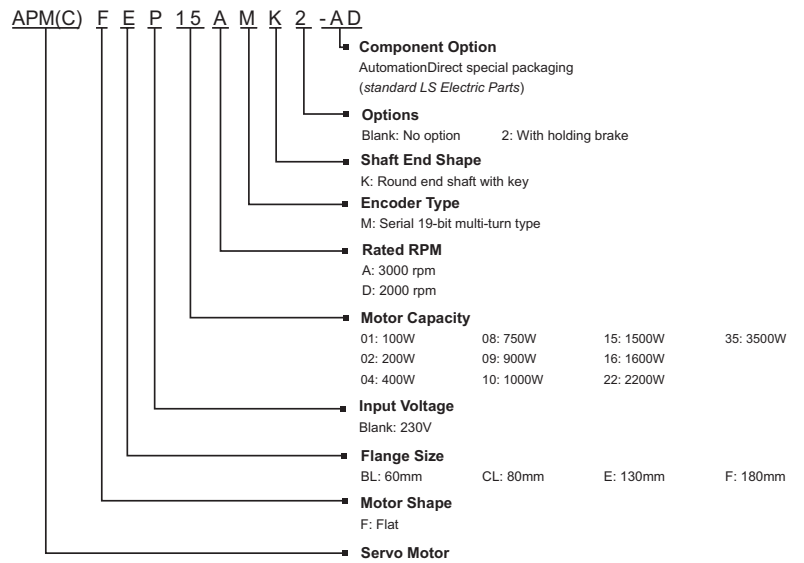

Example of what you will need to build a complete servo system:

Servo Drive



Servo Motor



Motor Power Cable



Motor Encoder Cable



I/O Interface



**Completed motor assembly
(with optional gearbox)**



NOTE: AMPC-FBL/FCL brake equipped motors will also require a separate brake power cable.



NOTE: Required programming software (free download). Use a standard USB-A to USB mini-B cable for connectivity (SV2-PGM-USB15, MOSAIC-CSU, or equivalent)



NOTE: If you need a gear box for your configuration, reference the gearbox chart on the previous page. Ratios of 5:1, 10:1, and 20:1 are available for each motor.





iX7NH Series Servo Systems

Torque to iX7NH System Quick Reference

Input Voltage	System Rated Torque (N·m)	System Maximum Torque (N·m)	Suggested Servo Motor	Required Servo Drive
120/230 VAC	0.32	0.96	APMC-FBL01AMK-AD	IX7NHA004U-AD
			APMC-FBL01AMK2-AD	
	0.64	1.91	APMC-FBL02AMK-AD	
			APMC-FBL02AMK2-AD	
	1.27	3.82	APMC-FBL04AMK-AD	
			APMC-FBL04AMK2-AD	
230VAC	2.39	7.16	APMC-FCL08AMK-AD	IX7NHA008U-AD
			APMC-FCL08AMK2-AD	
	3.10	9.55	APMC-FCL10AMK-AD	IX7NHA010U-AD
			APMC-FCL10AMK2-AD	
	4.77	14.32	APM-FE15AMK-AD	IX7NHA020U-AD
			APM-FE15AMK2-AD	
	7.63	22.92	APM-FE16DMK-AD	
			APM-FE16DMK2-AD	
	10.5	31.51	APM-FE22DMK-AD	IX7NHA035U-AD
			APM-FE22DMK2-AD	
	16.7	50.1	APM-FF35DMK-AD	
			APM-FF35DMK2-AD	

For information on using single-phase supply, please see "Drive Derating for Single-phase Usage" on page tSRV-32



iX7NH Series Servo Systems

iX7NH AC servo drive, motor, and cable combinations

xx = Cable length in meters
 BN/EN/PN = Standard cable (not continuous flex)
 BF/EF/PF = Flex-rated cable

AMK/DMK motors = no brake
 AMK2/DMK2 motors = mechanical holding brake

230V FBL/FCL Motor Systems

Type	System Torque Chart	iX7NH Drive	APM/APMC Motor	Power Cable	Encoder Cable	Brake Cable	I/O Cable and Breakout
100W Low Inertia System		IX7NHA004U-AD	APMC-FBL01AMK-AD	APCS-PNxxxLSX-AD	APCS-ENxxxES1-AD	n/a	APCS-L7NCN1Txx-AD or APCS-CN10xA-AD
				APCS-PFxxxLSX-AD	APCS-EFxxxES1-AD		
			APMC-FBL01AMK2-AD	APCS-PNxxxLSX-AD	APCS-ENxxxES1-AD	APCS-BNxxQS-AD	
				APCS-PFxxxLSX-AD	APCS-EFxxxES1-AD	APCS-BFxxQS-AD	
200W Low Inertia System		IX7NHA004U-AD	APMC-FBL02AMK-AD	APCS-PNxxxLSX-AD	APCS-ENxxxES1-AD	n/a	
				APCS-PFxxxLSX-AD	APCS-EFxxxES1-AD		
			APMC-FBL02AMK2-AD	APCS-PNxxxLSX-AD	APCS-ENxxxES1-AD	APCS-BNxxQS-AD	
				APCS-PFxxxLSX-AD	APCS-EFxxxES1-AD	APCS-BFxxQS-AD	
400W Low Inertia System		IX7NHA004U-AD	APMC-FBL04AMK-AD	APCS-PNxxxLSX-AD	APCS-ENxxxES1-AD	n/a	
				APCS-PFxxxLSX-AD	APCS-EFxxxES1-AD		
			APMC-FBL04AMK2-AD	APCS-PNxxxLSX-AD	APCS-ENxxxES1-AD	APCS-BNxxQS-AD	
				APCS-PFxxxLSX-AD	APCS-EFxxxES1-AD	APCS-BFxxQS-AD	
750W Low Inertia System		IX7NHA008U-AD	APMC-FCL08AMK-AD	APCS-PNxxxLSX-AD	APCS-ENxxxES1-AD	n/a	
				APCS-PFxxxLSX-AD	APCS-EFxxxES1-AD		
			APMC-FCL08AMK2-AD	APCS-PNxxxLSX-AD	APCS-ENxxxES1-AD	APCS-BNxxQS-AD	
				APCS-PFxxxLSX-AD	APCS-EFxxxES1-AD	APCS-BFxxQS-AD	



iX7NH Series Servo Systems

iX7NH AC servo drive, motor, and cable combinations, *continued*

xx = Cable length in meters

BN, EN, or PN = Standard cable (not continuous flex)

BF, EF, or PF = Flex-rated cable

AMK/DMK motors = no brake

AMK2/DMK2 motors = mechanical holding brake

Type	System Torque Chart	iX7NH Drive	APMC Motor	Power Cable	Encoder Cable	Brake Cable	I/O Cable and Breakout
1.0k W Low Inertia System		IX7NHA010U-AD*	APMC-FCL10AMK-AD	APCS-PNxxxLSX-AD	APCS-ENxxxES1-AD	n/a	APCS-L7NCN1Txx-AD
				APCS-PFxxxLSX-AD	APCS-EFxxxES1-AD		
			APMC-FCL10AMK2-AD	APCS-PNxxxLSX-AD	APCS-ENxxxES1-AD	APCS-BNxxQS-AD	APCS-CN10xA-AD
				APCS-PFxxxLSX-AD	APCS-EFxxxES1-AD	APCS-BFxxQS-AD	

* Note - For 1kW drive single-phase supply, derate motor max torque to 200%, or upsize the drive to iX7NHA020U-AD for the torque curves in the graph.

230V FE Motor Systems

Type	System Torque Chart	iX7NH Drive	APM/APMC Motor	Power Cable**	Encoder Cable	I/O Cable and Breakout
1.5 kW Low Inertia System		IX7NHA020U-AD***	APM-FE15AMK-AD	APCS-PNxxHSX1-AD	APCS-ENxxxDS1-AD	APCS-L7NCN1Txx-AD or APCS-CN10xA-AD
				APCS-PFxxHSX1-AD	APCS-EFxxxDS1-AD	
			APM-FE15AMK2-AD	APCS-PNxxNBX1-AD	APCS-ENxxxDS1-AD	
				APCS-PFxxNBX1-AD	APCS-EFxxxDS1-AD	
1.6 kW Medium Inertia System		IX7NHA020U-AD***	APM-FE16DMK-AD	APCS-PNxxHSX-AD	APCS-ENxxxDS1-AD	APCS-L7NCN1Txx-AD or APCS-CN10xA-AD
				APCS-PFxxHSX-AD	APCS-EFxxxDS1-AD	
			APM-FE16DMK2-AD	APCS-PNxxNBX-AD	APCS-ENxxxDS1-AD	
				APCS-PFxxNBX-AD	APCS-EFxxxDS1-AD	
2.2 kW Medium Inertia System		IX7NHA020U-AD***	APM-FE22DMK-AD	APCS-PNxxHSX-AD	APCS-ENxxxDS1-AD	APCS-L7NCN1Txx-AD or APCS-CN10xA-AD
				APCS-PFxxHSX-AD	APCS-EFxxxDS1-AD	
			APM-FE22DMK2-AD	APCS-PNxxNBX-AD	APCS-ENxxxDS1-AD	
				APCS-PFxxNBX-AD	APCS-EFxxxDS1-AD	

** Note - Power cables with "B" in the part number are combination power/brake cables, providing power for both the motor and the brake. A brake cable is not required.

*** Note - For single-phase supply, upsize the drive to iX7NHA035U-AD (2.2 kW motor max torque limited to 150%, 1.5/1.6 kW motors limited to 200% max motor torque).



iX7NH Series Servo Systems

iX7NH AC servo drive, motor, and cable combinations, *continued*

xx = Cable length in meters

BN, EN, or PN = Standard cable (not continuous flex)

BF, EF, or PF = Flex-rated cable

AMK/DMK motors = no brake

AMK2/DMK2 motors = mechanical holding brake

230V FF Motor Systems

Type	System Torque Chart	iX7NH Drive	APM/APMC Motor	Power Cable*	Encoder Cable	I/O Cable and Breakout
3.5 kW Medium Inertia System		IX7NHA035U-AD	APM-FF35DMK-AD	APCS-PNxxISX-AD	APCS-ENxxxDS1-AD	APCS-L7NCN1Txx-AD or APCS-CN10xA-AD
				APCS-PFxxISX-AD	APCS-EFxxxDS1-AD	
			APM-FF35DMK2-AD	APCS-PNxxPBX-AD	APCS-ENxxxDS1-AD	
				APCS-PFxxPBX-AD	APCS-EFxxxDS1-AD	

*Note - Power cables with "B" in the part number are combination power/brake cables, providing power for both the motor and the brake. A brake cable is not required.



iX7NH Series Servo Systems

i7XNH Servo drive specifications

i7XNH Servo Drive Specifications						
Model		IX7NHA004U-AD	IX7NHA008U-AD	IX7NHA010U-AD	IX7NHA020U-AD	IX7NHA035U-AD
Price		\$495.00	\$610.00	\$620.00	\$700.00	\$726.00
Drawing		PDF	PDF	PDF	PDF	PDF
Power	Input Power	One phase 100–120 VAC One phase 200–240 VAC	One phase 200–240 VAC	Three phase 200–230 VAC (-15 to +10%), 50–60Hz**		
	Rated Current [Amps]	3.0	5.2	6.75	13.5	16.0
	Peak Current [Amps]	10.5	18.2	20.25	40.5	48.0
	Inrush Current	34A @ 240VAC	57A @ 240VAC			
Encoder Type		Quadrature (Incremental), BiSS-B, BiSS-C (Absolute, Incremental) Tamagawa Serial (Absolute, Incremental), EnDat 2.2, Sinusoidal, Analog Hall, SSI, Nikon, Panasonic				
Encoder Decimation Output		Differential Line Drive 3 channels AO, /AO, BO, /BO, ZO, /ZO up to 6.5 Mpps on 4x interpolation				
Control Performance	Speed Control Range	Maximum 1:5000				
	Frequency Response	Maximum 1kHz (for a 19-bit serial encoder)				
	Speed Variation Ratio	± 0.01 % or lower (when load changes between 0 and 100%), ± 0.1 % or lower (temperature 25±10°C)				
	Accel/Decel Time	Straight line acceleration/deceleration (0–10,000 ms) and/or S-curve (0–1000 ms)				
	Torque Control Repetition Accuracy	± 1% or less				
Recommended Breaker (UL 489)		15A (max)		30A (max)		
Recommended Fuse***		15A (max)		30A (max)		
SCCR Rating***		5kA				
EtherCAT® Specification	Communication Standard	FoE (Firmware download), EoE (parameter setting by UDP, Tuning, Secondary function, Parameter copy) CoE (IEC 61158 Type 12, IEC 61800-7 CiA 402 Drive Profile)				
	Physical Layer	100BASE-TX (IEEE802.3)				
	Connector	RJ45 x 2				
	Communication Distance	Distance between nodes 100m or less				
	DC (Distributed Clock)	Synchronization by DC (Distributed Clock) mode. Minimum DC cycle: 125µs				
	LED Display	L/A0 & L/A1 (Link Activity) LED for EtherCAT In & Out status				
Digital I/O Specifications	Digital Input	Input voltage range: 12–24 VDC, total 6 input channels (configurable) 15 different selectable functions for assignment. (*POT, *NOT, *HOME, *STOP, *PCON, *GAIN2, P_CL, N_CL, PROBE1, PROBE2, EMG, A_RST, SV_ON, LVSF1, LVSF2)				
	Digital Output	Service rating: 24VDC ± 10%, 120mA, 3 output channels are configurable 11 different selectable functions for assignment (*BRAKE, *ALARM, *READY, ZSPD, INPOS, TLMT, VLMT, INPOS2, INSPD, WARN, TGON)				
Analog I/O	Analog Input	Input voltage range: ±10V Function: analog torque limit (1 channel, not configurable)				
	Analog Output	12-bit resolution, ±10V output range, total 2 channels (configurable): able to selectively configure 25 types of output				
Continued on next page						

* Basic allocation signal.

** See Single-phase power input section on the following page for single phase considerations.

*** Use class CC or High Speed J (JHL series) current limiting fuses to prevent nuisance tripping and to increase panel SCCR rating.

iX7NH Servo drive specifications, *continued*

iX7NH Servo Drive Specifications, <i>continued</i>		
<i>Continued from previous page</i>		
<i>Model</i>	<i>All iX7NH Series Drives</i>	
<i>Safety Function</i>	2 Input Channels (STO1 and STO2), 1 Output Channel (EDM)	
USB Communication	<i>Function</i>	Firmware download, tuning, test drive, monitoring, parameter duplication
	<i>Communication Standard</i>	Complies with USB 2.0 Full Speed and OTG 2.0 standards.
	<i>Accessible Device</i>	PC or USB storage device
Internal Function	<i>Dynamic Braking</i>	Standard built-in brake (activated when the servo alarm goes off or when the servo is off)
	<i>Regenerative Braking</i>	Built-in by default
	<i>Display Function</i>	7-segment display (5 digits)
	<i>Self-setting Function</i>	Drive node address setting is possible using two rotary switches
	<i>Additional Function</i>	Gain tuning, alarm history, jog operation, home searching
	<i>Protection Function</i>	Overcurrent, overload, overheat, overvoltage, insufficient voltage, overspeed, abnormal state of encoder, position following error, current detecting error
Operation Environment	<i>Operating Temperature</i>	0–50 °C [32–122 °F]
	<i>Storage Temperature</i>	-20–65 °C [-4–149 °F]
	<i>Operating Humidity</i>	Under 80% relative humidity
	<i>Storage Humidity</i>	Under 90% relative humidity (non-condensing)
	<i>Environment</i>	Keep indoors, avoid corrosive/flammable gas or liquid
<i>Approvals</i>	cUL _{US} (E479434), CE, UKCA, KC	

Single-phase Power Input

Although designed with 3-phase AC input power in mind, some iX7NH systems are capable of supporting single-phase AC input power. With three phase AC supply, the iX7NH motor/drive combination supplies 300% rated maximum motor torque (see the instantaneous Operation Range in the torque-speed charts on previous pages). With single phase AC supply some ratings will have limited maximum/intermittent motor torque, and/or the next larger drive size will be required.

Drive Derating for Single-phase Usage		
<i>3-phase Motor Rating</i>	<i>Drive to use with Single-phase Input</i>	<i>Motor Torque Derating for Single-phase Input</i>
100W/200W/400W	iX7NHA004U-AD (400W)	No upsizing/derating required. Single phase and three phase input both produce 300% max torque
750W	iX7NHA008U-AD (1kW)	No upsizing/derating required. Single phase and three phase input both produce 300% max torque
1kW	iX7NHA010U-AD (1kW) or iX7NHA020U-AD (2kW)	2kW drive produces 300% max torque. The 1kW drive can be used, but the motor can only provide 200% max torque.
1.5 kW/1.6 kW	iX7NHA035U-AD (3.5 kW)	With single phase supply, this drive only produces 150% max motor torque with a 2.2 kW motor. 3.5kW drive produces 200% max torque with 1.5 kW and 1.6 kW motors.
2.2 kW		
3.5 kW	n/a	No single phase capability

iX7NH Drive Standard Installation

iX7NH Drive Installation Spacing

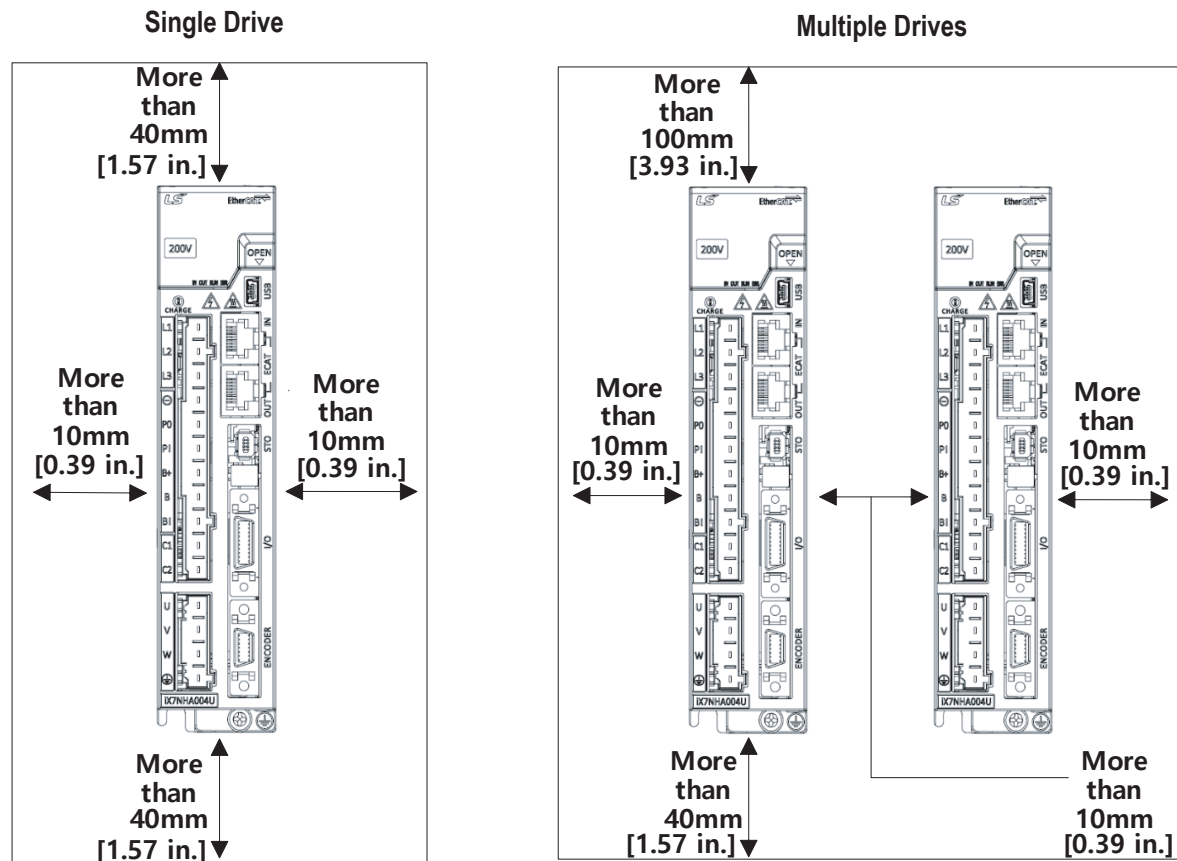

iX7NH Drive Installation Concerns:

- Install external regenerative resistors so that any heat generated does not affect the drive.
- Vertical installation only. For proper heat dissipation, ensure the back of the drive makes good contact with the subpanel.
- Protect the drive from metal chips and other falling debris during control panel assembly.
- Make sure that oil, water, or metal dust do not enter the drive.
- Protect the control panel by using an air purge system when installing it in any area where there are harmful gases or dust.

iX7NH Drive Wiring

iX7NH Power Supply Wiring



NOTE: Single-phase can use 2 of R, S, or T. See "Single-phase Power Input" on page tSRV-32 for more information.

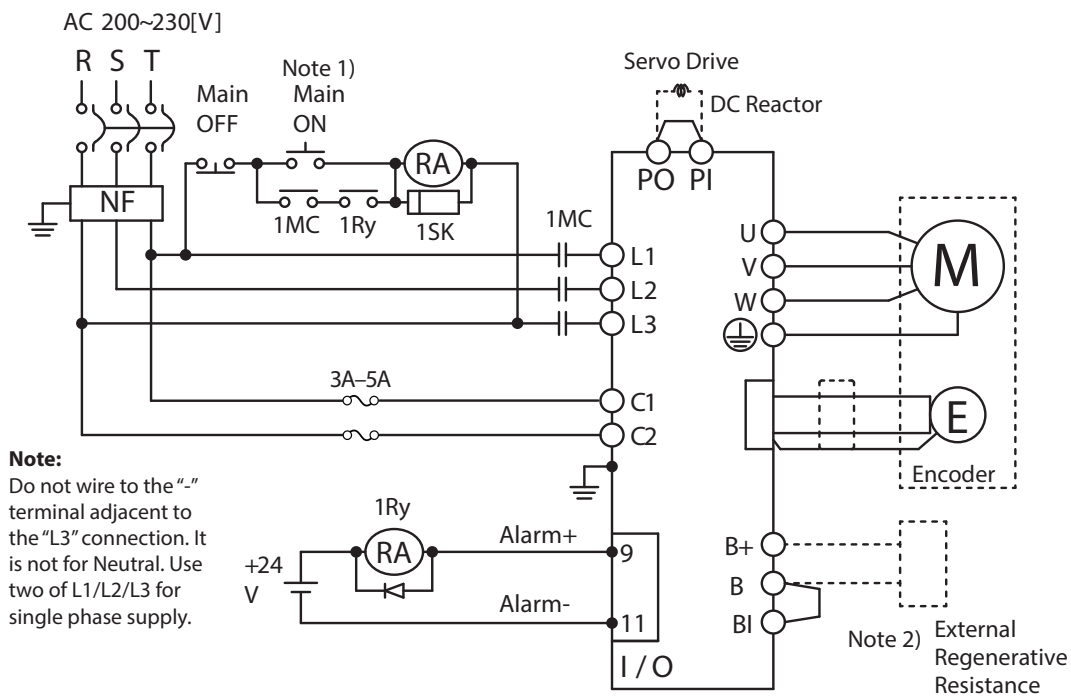

NOTE 1: About 2.5–3 seconds are required from main power supply to alarm signal output. Hold the main power on for 3 seconds until the alarm circuit ("1Ry") will latch main power ON.



NOTES 2 & 3: Remove the jumper for the internal resistor between B and BI, and connect the external resistor to the B+ and B pins. If an external regen resistor is required, see the available regen resistors under the Motion Control category at AutomationDirect.com (APCS-140R50-AD, APCS-300R30-AD, etc.).

LS ELECTRIC L7C AC Servo Systems

Drive features

- Power: 100W–1kW single-phase 220VAC
- Fully digital with up to 1kHz velocity loop response
- Easy setup and diagnostics with built-in keypad/display or the DriveCM PC-based software
- Field upgradeable firmware ensures the drive can always be upgraded to the latest operating system
- Command options include:
 - \pm 10V torque or velocity command
 - Pulse train or master encoder position command (accepts line driver or open collector) with real-time selectable electronic gearing
 - Internal Indexer for position/speed-based moves. 64 individual move statements can be configured in the drive. Each Index contains its own distance, speed, accel, decel, and dwell parameters. These indexes can be set up through DriveCM software or modified in real-time with serial communication (PLC, HMI, etc.). The indexes can be initiated via Digital Inputs or through serial comms.
- The 1 kHz bandwidth allows for high-level automatic tuning. Several modes of tuning are available including Off-Line Auto Tuning (the drive initiates its own move commands while Auto tuning), On-Line Auto Tuning (an external controller sends the move commands while the drive Auto tunes), and Manual Tuning (all tuning values are adjusted by the user).
- Optically isolated digital inputs (10) and (5) general purpose (user-configurable) outputs + (3) outputs permanently configured as alarm/status binary code, analog inputs for speed and torque control (2), and line driver output for encoder (with scalable resolution).
- Advanced Scope feature that can monitor a variety of command and status signals, including output speed, torque, power, etc.



Motor features

- Low inertia models:
 - 100W, 200W, 400W, 750W and 1kW
 - Speeds up to 5,000 rpm
- Permanent magnet 3-phase synchronous motor
- Keyed drive shafts support clamp-on style couplings or key-style couplings
- Integrated encoder with 17-bit resolution (131,072 pulses per revolution)
- Optional 24 VDC spring-set holding brakes (AYK2 motors)
- Standard hook-up cables for motor power, encoder, and brake (separate brake cable for brake motors)
- Motor cables available in standard or flex-rated lengths of 3, 5, 10, and 20m
- Standard 50-pin DIN-rail mounted break-out kit for the drive's CN1 connector (with screw terminal connections), or 50-pin cables with flying leads

Note: These parts available for sale to North American locations only.

Tuning Technology

The L7C drive closes the loop on current, velocity, and position (depending on control mode selection). The 1kHz bandwidth in the drive assures precise speed and current control and easy tuning. Proportional gain, integral gain and compensation, feed forward compensation, command low pass filter, and four (4) notch filters for resonance suppression are available. Auto Tuning has been greatly improved and can tune FBL/FCL motors up to 20:1 inertia mismatch.

There is an inertia estimation function that analyzes the motor and load to measure how much inertia is coupled to the motor.

The drive has several tuning methods available:

- Online Auto Tuning—the drive can either tune the load live while an external controller moves the load to different positions or using the drive's internal tuning motion profile.
- Offline Auto Tuning—the drive tunes the load using the drive's internal tuning motion profile.
- Manual Tuning—all parameters are available to give power users the ultimate flexibility to tune their systems.

Built-in Indexer

While the L7C drives can accept traditional commands from host controllers, they can also provide their own internal motion control. 64 point-to-point position moves can be configured in the drive. These moves can be populated through the DriveCM configuration software or they can be written to by a PLC through the drive's RS422/485 serial port. The moves can be initiated by digital inputs or by serial commands, and can be sequenced internally with delays in between the moves or moves can be linked together so they are processed one after the other.

Multi-axis systems can be controlled via digital inputs, or serial communication. The motion can be commanded from a powerful external controller that sends out high speed pulses to each drive, or the motion can be initiated by a low-level controller (the simplest CLICK PLC) since each drive has a powerful indexer inside. Applications include press feeds, auger fillers, rotary tables, robots for pick and place, test or assembly operations, drilling, cutting, tapping, and similar applications using simple index moves for single or multi-axis motion.

Optional Holding Brake

Each L7C motor can be ordered with an optional 24VDC spring-set holding brake that holds the motor in place when power is removed.

LS Electric MSS Series In-Line Planetary Precision Gearboxes for Servo Motors

Need more torque from the motor? Have an inertia balancing issue in your design? The LS Electric MSS series gearboxes easily mate to FBL/FCL motors. Everything you need to mount your LS electric servo is included!

- Three gear ratios available (5:1, 10:1, 20:1)
- Mounting hardware included for attaching to FBL/FCL motors.
- Industry-standard mounting dimensions
- Thread-in mounting style
- Very low backlash: 7 arc-min single stage (5:1 and 10:1 ratios), 9 arc-min for two-stage (20:1 ratios).
- 1-year warranty



LS ELECTRIC L7C Series AC Servo Systems

Servo drive overview

LED Display

The 5-digit display is used to indicate servo status and alarm. The keys can be used to configure the drive and to set up monitoring values (but we highly recommend using the Drive CM software instead).

Model Number

Clearly displayed on the front panel for easy identification.

Main Power Terminal

Incoming single phase 200-230 VAC (-15% to +10%, 50/60Hz)

Regenerative Resistor Terminal

Connection for optional external braking resistor (APCS-140R50-AD or APCS-300R30-AD)

Motor Output Terminal

Output power to the servo motor. LS motor power cables available in 3, 5, 10, and 20 meter lengths in standard and flexing cables.

Ground Terminals

Separate ground screws for incoming power supply ground and motor cable ground.

Keypad

Four Function keys:
MODE, UP, DOWN, SET

USB Connector

Used by Drive CM software for servo configuration. Connect with a standard USB A to USB miniB cable (SV2-PGM-USB15, MOSAIC-CSU, or similar).

CN1 I/O Signal Connector

50-pin CN1 connector for drive I/O. Signals include high speed pulse inputs, 10 digital inputs, 8 digital outputs, 2 analog inputs (voltage and torque), serial Modbus RS422 (compatible with RS485 PLCs) and scalable encoder output.

Encoder Connector

14-pin CN2 connector for the motor encoder. LS Encoder cables available in 3, 5, 10, and 20 meter lengths in standard and flexing cables.

The LS Electric L7C servo drives are fully digital and include over 300 parameters to configure the drive for almost any application. For convenience, the parameters are grouped into several categories including:

- Basic parameters
- Gain parameters
- I/O parameters
- Velocity parameters
- Misc. parameters
- Monitor parameters
- Index parameters

All parameters have commonly used default values which allow you to operate the L7C drive "out-of-the-box". The drive auto-detects the

LS servo motor (through the serial encoder) and sets up the default gains and limits based on the connected motor.

The drive can still be easily configured to your specific application, however. The Drive CM configuration software has a built-in Setup Wizard that will guide you through all the basic setup parameters. So, whether you want to use high speed pulse input, analog velocity, analog torque, or the powerful internal indexer for a control mode (or any multi-mode combination of these modes), the Setup Wizard will quickly and easily get your application started – from setting up the I/O to determining the appropriate homing sequence.

After configuration is complete, the Auto Tune features of the drive will get your application tuned for optimal responsiveness and performance.

LS ELECTRIC L7C Series AC Servo Systems

Servo motor overview

Encoder Connector

9-pin watertight connector (8 pins used) for the 17-bit serial encoder. The encoder transmits motor/encoder identification information to the drive at power-up and it sends position feedback during operation.

Low Inertia Motors

Low inertia designs result in high responsiveness and high speeds.

- 100W 60mm flange
- 200W 60mm flange
- 400W 60mm flange
- 750W 80mm flange
- 1kW 80mm flange

Non-Braking Motor

Motor Power Connector

4-pin watertight connector for motor power (U, V, W, and ground)

Keyed Shafts

"FBL and FCL motors are supplied with extra-large keyways, and slightly oversized keys which must be "fitted" into the keyway for performance and longevity. Clamp or compression couplings (without key) are recommended".

- 100W 14mm diameter shaft
- 200W 14mm diameter shaft
- 400W 14mm diameter shaft
- 750W 19mm diameter shaft
- 1kW 19mm diameter shaft



IP67 Housing

All LS Electric L7C motors have keyed shafts for use with servo-grade clamp or compression couplings (recommended) or servo-grade keyed couplings. Some sanding/filing of the key may be required before pressing into the keyway. Do not modify the shaft/keyway.

Encoder Connector

9-pin watertight connector (8 pins used) for the 17-bit serial encoder. The encoder transmits motor/encoder identification information to the drive at power-up and it sends position feedback during operation.

Brake Power Connector

2-pin watertight connector available on brake motors only. The 24VDC brake is located between the motor coils and the encoder. Motors ending in AYK2 have brakes. The brakes must have 24VDC applied to them before the motor is set in motion.

Brake Motor

Motor Power Connector

4-pin watertight connector for motor power (U, V, W, and ground)

Keyed Shafts

"FBL and FCL motors are supplied with extra-large keyways, and slightly oversized keys which must be "fitted" into the keyway for performance and longevity. Clamp or compression couplings (without key) are recommended".

- 100W 14mm diameter shaft
- 200W 14mm diameter shaft
- 400W 14mm diameter shaft
- 750W 19mm diameter shaft
- 1kW 19mm diameter shaft



IP67 Housing

LS ELECTRIC L7C AC Servo Systems

How to select and apply L7C systems

The primary purpose of the AC servo system is to precisely control the motion of the load. The most fundamental considerations in selecting the servo system are "reflected" load inertia, servo system maximum speed requirement, servo system continuous torque requirement, and servo system peak torque requirement. In a retrofit application, select the largest torque servo system that most closely matches these parameters for the system being replaced. In a new application, these parameters should be determined through calculation and/or

measurement. The Drive CM software has the ability to measure the load (reflected) inertia and accurately measure the motor torque output.

AutomationDirect has teamed with Copperhill Technologies to provide free servo-sizing software. "VisualSizer-SureServo" software will assist in determining the correct motor and drive for your application by calculating the reflected load inertia and required speed and torque based on the load configuration. "VisualSizer-SureServo" software can be downloaded from <https://support.automationdirect.com/products/sureservo.html>.

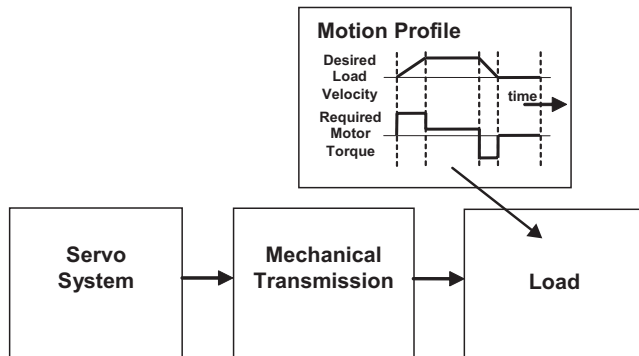

1. "Reflected" load inertia

The inertia of everything attached to the servo motor driveshaft needs to be considered and the total "reflected" inertia needs to be determined. This means that all elements of any mechanical transmission and load inertia need to be translated into an equivalent inertia as if attached directly to the motor driveshaft. The ratio of "reflected" load inertia to motor inertia needs to be carefully considered when selecting the servo system.

In general, applications that need high response or bandwidth

will benefit from keeping the ratio of load inertia to motor inertia as low as possible and ideally under 10:1. L7C Auto Tuning will still tune a system with very high response, up to 20:1 inertia mismatch. Higher system ratios can be implemented, but corresponding lower bandwidth or responsiveness must be accepted. The servo response including the attached load inertia is determined by the servo tuning. The L7C servo systems may be tuned automatically by the software/drive or manually by the user.

2. Torque and speed

With knowledge of the motion profile and any mechanical transmission between the motor and load, calculations can be made to determine the required servo motor continuous torque, peak torque, and maximum motor speed. The required amount of continuous torque must fall inside the continuous operating region of the system torque-speed curve (you can check the continuous torque at the average speed of the motion profile). The required amount of peak torque must also fall within the servo system's intermittent operating region of the system torque-speed curve (you need to check this value at the required maximum speed or torque). If you have an L7C system, these values are easily captured and recorded with the Scope feature built into the Drive CM software. If you are designing the system from scratch, use VisualSizer to define the system and calculate expected inertia and required power.

Compare the application's Continuous and Intermittent torque requirements to the torque-speed curves found in Chapter 16 of the L7C User Manual.

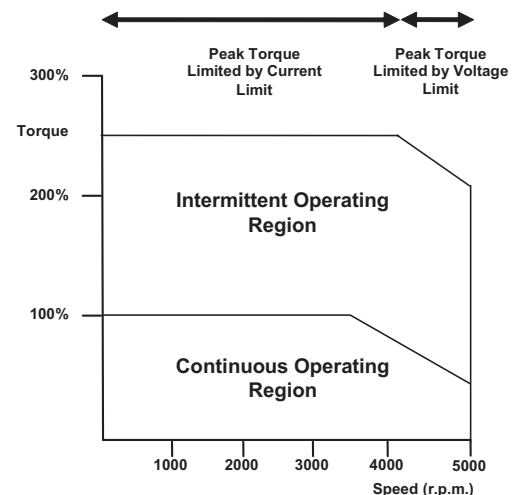

LS ELECTRIC L7C AC Servo Systems

Application tip - coupling considerations

The LS Electric FBL/FCL motors have keyed shafts that can be used with keyed couplings or with clamp-on or compression style couplings. For standard keyed couplings, the servo key must be "fitted" into the keyway for optimum performance and longevity. Some minor filing and pressing of the key may be required. "Servo-grade" clamp-on or compression style couplings

are usually the best choice when you consider stiffness, torque rating, and inertia. Higher stiffness (lb-in/radian) is needed for better response but there is a trade-off between stiffness and the added inertia of the coupling. Concerning the torque rating of the coupling, use a safety factor of 1.25 over the servo's **peak** torque requirement of your application.

[Click here for Available Couplings](#)

Mechanical transmissions

Common mechanical transmissions include leadscrews, rack & pinion mechanisms, conveyors, gears, and timing belts. The use of leadscrew, rack & pinion, or conveyor are common ways to translate the rotary motion of the servo motor into linear motion of the load. Matched gearboxes are available from LS Electric that will work with the FBL and FCL motors. Each gearbox is selected to accept the 300% maximum available torque that could be generated by the motor. Gearboxes are available in 5:1, 10:1, and 20:1 ratios. The use of a speed reducer such as a gearbox or timing belt can be very beneficial as follows:

1. Reduction of reflected load inertia

As a general rule, it is beneficial to keep the reflected load inertia as low as possible while using the full range of servo speed. The LS Electric motors can rotate at a rated speed of 3000rpm (rated torque at rated speed). Their max speed (slightly less available torque) is 5000rpm. See the speed-torque curves for more information.

Example: A gearbox reduces the motor's required torque by a factor of the gear ratio, and reduces the reflected load inertia by a factor of the gear ratio squared. A 10:1 gearbox reduces output speed to 1/10, increases output torque 10 times, and decreases reflected inertia to 1/100.

However, when investigating the effect of different speed reduction ratios DO NOT forget to include the added inertia of couplings, gearbox, or timing belt pulleys. These added inertias can be significant, and can negate any inertia reduction due to the speed reduction.

2. Low speed and high torque applications

If the application requires low speed and high torque then it is common to introduce a speed reducer so that the servo system can operate over more of the available speed range. This could also have the added benefit of reducing the servo motor torque requirement which could allow you to use a smaller and lower cost servo system. Additional benefits are also possible with reduction in reflected inertia, increased number of motor encoder counts at the load, and increased ability to reject load disturbances due to mechanical advantage of the speed reducer.

3. Space limitations and motor orientation

FBL/FCL motors can be mounted in any orientation, but the shaft seal should not be immersed in oil (open-frame gearbox, etc.). Reducers can possibly allow the use of a smaller motor or allow the motor to be repositioned.



Motor	Brake Motor	LS Electric MSS Planetary In-Line Gearboxes		
		5:1 Gearbox	10:1 Gearbox	20:1 Gearbox
APMC-FBL01AYK-AD	APMC-FBL01AYK2-AD	96200004 (MSS0601A-005KS-B3110103C14)	96200005 (MSS0601A-010KS-B3110103C14)	96200103 (MSS0902B-020KS-B3110103C14)
APMC-FBL02AYK-AD	APMC-FBL02AYK2-AD			
APMC-FBL04AYK-AD	APMC-FBL04AYK2-AD			
APMC-FCL08AYK-AD	APMC-FCL08AYK2-AD	96200007 (MSS0901A-005KS-C3110103C19)	96200008 (MSS0901A-010KS-C3110103C19)	96200257 (MSS1152B-020KS-C3110103C19)
APMC-FCL10AYK-AD	APMC-FCL10AYK2-AD			

Here is a link to our [Timing Belts and Pulleys](#)

Ordering guide instructions

The following four pages are your ordering guide for LS Electric L7C servo systems. Each system has a torque-speed curve included for reference. This is the fundamental information that you need to select the servo motor and matching drive for your application.

Each system needs:

- Motor
- Drive
- Motor Power Cable
- Motor Encoder Cable
- I/O connections (either a 50-pin CN1 cable+terminals kit or a 50-pin flying lead cable(user provides terminal blocks))
- For brake motors you will also need a brake cable (connectorized on the motor end, two ferruled flying leads on the opposite end).

LS ELECTRIC L7C Series AC Servo Systems

L7C series drives and motors part numbering system

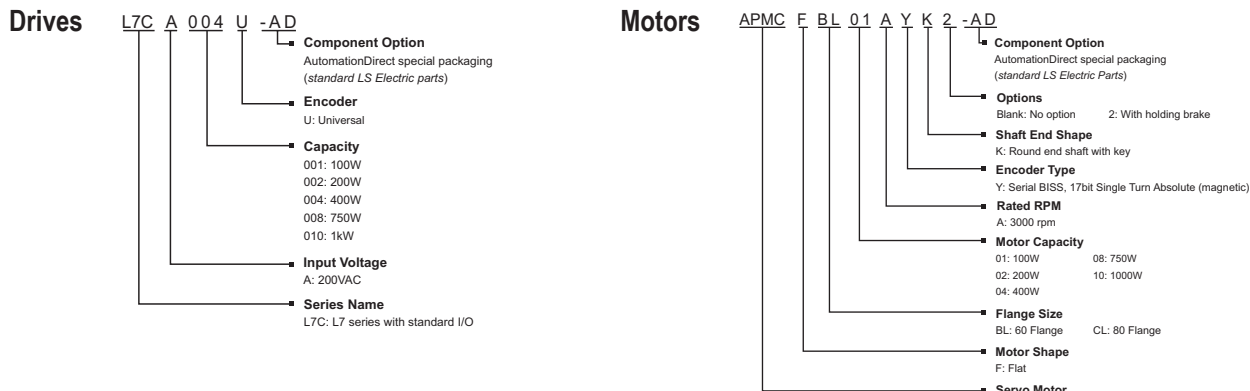

Example of what you will need to build a complete servo system:



NOTE: Unit can be programmed via keypad. Optional programming software (free download). Use a standard USB-A to USB miniB cable for connectivity (SV2-PGM-USB15, MOSAIC-CSU, or equivalent)

NOTE: If you need a gear box for your configuration, reference the gearbox chart on the previous page. Ratios of 5:1, 10:1, and 20:1 are available for each FBL/FCL motor.



Torque to L7C System Quick Reference

System Rated Torque (N·m)	System Maximum Torque (N·m)	Suggested Servo Motor	Required Servo Drive
0.32	0.96	APMC-FBL01AYK-AD	L7CA004U-AD
		APMC-FBL01AYK2-AD	
0.64	1.91	APMC-FBL02AYK-AD	
		APMC-FBL02AYK2-AD	
1.27	3.82	APMC-FBL04AYK-AD	
		APMC-FBL04AYK2-AD	
2.39	7.16	APMC-FCL08AYK-AD	L7CA010U-AD
		APMC-FCL08AYK2-AD	
3.18	9.55	APMC-FCL10AYK-AD	
		APMC-FCL10AYK2-AD	

LS ELECTRIC L7C Series AC Servo Systems

L7C AC servo drive, motor, and cable combinations

xx = Cable length in meters

BN, EN, or PN = Standard cable (not continuous flex)

BF, EF, or PF = Flex-rated cable

AYK motors = no brake

AYK2 motors = mechanical holding brake

Type	System Torque Chart	L7C Drive	APMC Motor	Power Cable	Encoder Cable	Brake Cable	I/O Cable and Breakout
100W Low Inertia System		L7CA004U-AD	APMC-FBL01AYK-AD	APCS-PNxxLSC-AD	APCS-ENxxES-AD	n/a	APC-VSCN1Txx-AD or APC-CN10xA-AD
				APCS-PFxxLSC-AD	APCS-EFxxES-AD	n/a	
			APMC-FBL01AYK2-AD	APCS-PNxxLSC-AD	APCS-ENxxES-AD	APCS-BNxxQS-AD	
				APCS-PFxxLSC-AD	APCS-EFxxES-AD	APCS-BFxxQS-AD	
200W Low Inertia System		L7CA004U-AD	APMC-FBL02AYK-AD	APCS-PNxxLSC-AD	APCS-ENxxES-AD	n/a	
				APCS-PFxxLSC-AD	APCS-EFxxES-AD	n/a	
			APMC-FBL02AYK2-AD	APCS-PNxxLSC-AD	APCS-ENxxES-AD	APCS-BNxxQS-AD	
				APCS-PFxxLSC-AD	APCS-EFxxES-AD	APCS-BFxxQS-AD	
400W Low Inertia System		L7CA004U-AD	APMC-FBL04AYK-AD	APCS-PNxxLSC-AD	APCS-ENxxES-AD	n/a	
				APCS-PFxxLSC-AD	APCS-EFxxES-AD	n/a	
			APMC-FBL04AYK2-AD	APCS-PNxxLSC-AD	APCS-ENxxES-AD	APCS-BNxxQS-AD	
				APCS-PFxxLSC-AD	APCS-EFxxES-AD	APCS-BFxxQS-AD	

LS ELECTRIC L7C Series AC Servo Systems

L7C AC servo drive, motor, and cable combinations, *continued*

Type	System Torque Chart	L7C Drive	APMC Motor	Power Cable	Encoder Cable	Brake Cable	I/O Cable and Breakout	
750W Low Inertia System		L7CA010U-AD	APMC-FCL08AYK-AD	APCS-PNxxLSC-AD	APCS-ENxxES-AD	n/a	APC-VSCN1Txx-AD or APC-CN10xA-AD	
				APCS-PFxxLSC-AD	APCS-EFxxES-AD	n/a		
			APMC-FCL08AYK2-AD	APCS-PNxxLSC-AD	APCS-ENxxES-AD	APCS-BNxxQS-AD		
				APCS-PFxxLSC-AD	APCS-EFxxES-AD	APCS-BFxxQS-AD		
1.0kW Low Inertia System		L7CA010U-AD	APMC-FCL10AYK-AD	APCS-PNxxLSC-AD	APCS-ENxxES-AD	n/a		
				APCS-PFxxLSC-AD	APCS-EFxxES-AD	n/a		
			APMC-FCL10AYK2-AD	APCS-PNxxLSC-AD	APCS-ENxxES-AD	APCS-BNxxQS-AD		
				APCS-PFxxLSC-AD	APCS-EFxxES-AD	APCS-BFxxQS-AD		

LS ELECTRIC L7C Series AC Servo Systems

L7C Servo drive specifications

L7C Servo Drive Specifications			
Model	<u>L7CA004U-AD</u>	<u>L7CA010U-AD</u>	
	Price	\$286.00	\$360.00
	Drawing	PDF	PDF
Power	Input Power	Single phase AC200 - 230V(-15 to +10%), 50-60Hz	
	Rated Current [Amps]	3.6	8.0
	Peak Current [Amps]	9.0	20.25
	Inrush Current	34A @ 240VAC	36A @ 240VAC
Control Performance	Speed Control Range	Maximum 1:5000	
	Frequency Response	Maximum 1KHz or above (when using 17-Bit Serial Encoder)	
	Speed Variation Ratio	± 0.01 % or lower (when load changes between 0 and 100%), ± 0.1 % or lower (temperature 25±10°C)	
	Accel/Decel Time	Straight or S-curve acceleration/deceleration (0-10,000 ms), increment by 1ms	
	Input Frequency	1Mpps, line driver / 200kpps, open collector	
	Input Pulse Type	Pulse+Direction, CW+CCW, A/B Phase	
	Recommended Breaker	5A max	10A max
	Recommended Fuse	15A max	30A max
	SCCR Rating	5000A	
RS-422	Specification	ANSI/TIA/EIA - 422 standard specifications - connects to PLCs with RS485 ports (Click, P-Series, Do-More, etc.)	
	Protocol	MODBUS-RTU	
	Synchro Method	Asynchronous	
	Power Consumption	100mA	
	Transmission Speed (bps)	9,600 / 19,200 / 38,400 / 57,600	
	Distance	200m maximum	
	Terminating Resistance	Optional built-in 120Ω resistor for end-of-line termination	
Digital I/O Specifications	Digital Input	Input voltage range: 12-24 VDC Total 10 input channels (configurable) 34 different selectable functions for assignment. (*SV_ON, *SPD/LVSF1, *SPD2/LVSF2, *SPD3, *A-RST, *JDIR, *POT, *NOT, *EMG, *STOP, START, REGT, HOME, HSTART, ISEL0, ISEL1, ISEL2, ISEL3, ISEL4, ISEL5, PCON, GAIN2, P_CL, N_CL, MODE, PAUSE, ABSRQ, JSTART, PCLR, AOVR, INHIBIT, EGEAR1, EGEAR2, ABS_RESET)	
	Digital Output	Service rating: 24VDC ± 10%, 120mA 5 of 8 output channels are configurable, 3 channels are fixed with AL00, AL01, and AL02 19 different selectable functions for assignment (*ALARM, *READY, *ZSPD, *BREAK, *INPOS1, ORG, EOS, TGON, TLMT, VLMT, INSPD, WARN, INPOS2, IOUT0, IOUT1, IOUT2, IOUT3, IOUT4, IOUT5)	
	Analog Input	2 channel Analog speed input (Command/Override) ± 10V Analog torque input (Command/Override) ± 10V	
USB Communication	Connect	PC	
	Communication Standard	USB 2.0 full speed (applies standard)	
	Specification	PC, USB 2.0 full speed (applies standard)	
Continued on next page			

* Basic allocation signal

LS ELECTRIC L7C Series AC Servo Systems

L7C Servo drive specifications, *continued*

L7C Servo Drive Specifications, <i>continued</i>			
<i>Continued from previous page</i>			
Model	<u>L7CA004U-AD</u>	<u>L7CA010U-AD</u>	
Internal Function	Dynamic Braking	Standard built-in brake (activated when the servo alarm goes off or when the servo is OFF)	
	Regenerative Braking	3.0 kW capacity with external resistor APCS-140R50	5.0 kW capacity with external resistor APCS-300R30
	Display Function	7 segments (5DIGIT)	
	Additional Function	Gain tuning, alarm history, JOG operation, homing	
	Protection Function	Excessive current/voltage/overload/overheating/speed, excessive current limit, low voltage, encoder/ position following/current sensing fail	
Operation Environment	Operating Temperature	0–50 °C	
	Storage Temperature	-20 to -65°C	
	Operating Humidity	Below 80% relative humidity	
	Storage Humidity	Below 90% relative humidity (avoid dew-condensation)	
	Environment	Indoor, avoid corrosive, inflammable gas, or liquid and electrically conductive dust	
Approvals		cUL _{US} (E479434), CE	

LS ELECTRIC L7C Series AC Servo Systems

L7C Drive Standard Installation

L7C Drive Installation Spacing

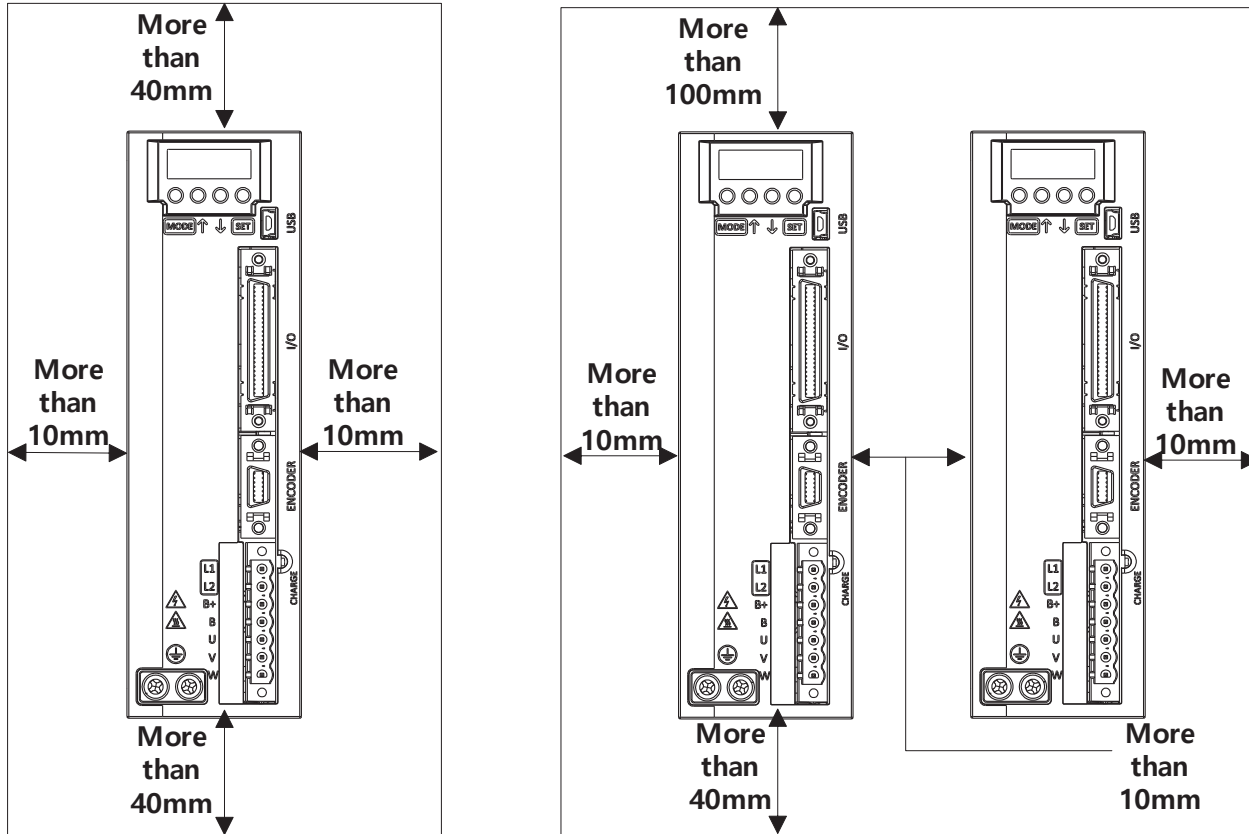

L7C Drive Installation Concerns:

- Install external regenerative resistors so that any heat generated does not affect the drive.
- Vertical installation only. For proper heat dissipation, ensure the back of the drive makes good contact with the subpanel.
- Protect the drive from metal chips and other falling debris during control panel assembly.
- Make sure that oil, water, or metal dust do not enter the drive.
- Protect the control panel by using an air purge system when installing it in any area where there are harmful gases or dust.

LS ELECTRIC L7C Series AC Servo Systems

L7C Drive Wiring

L7C Power Supply Wiring

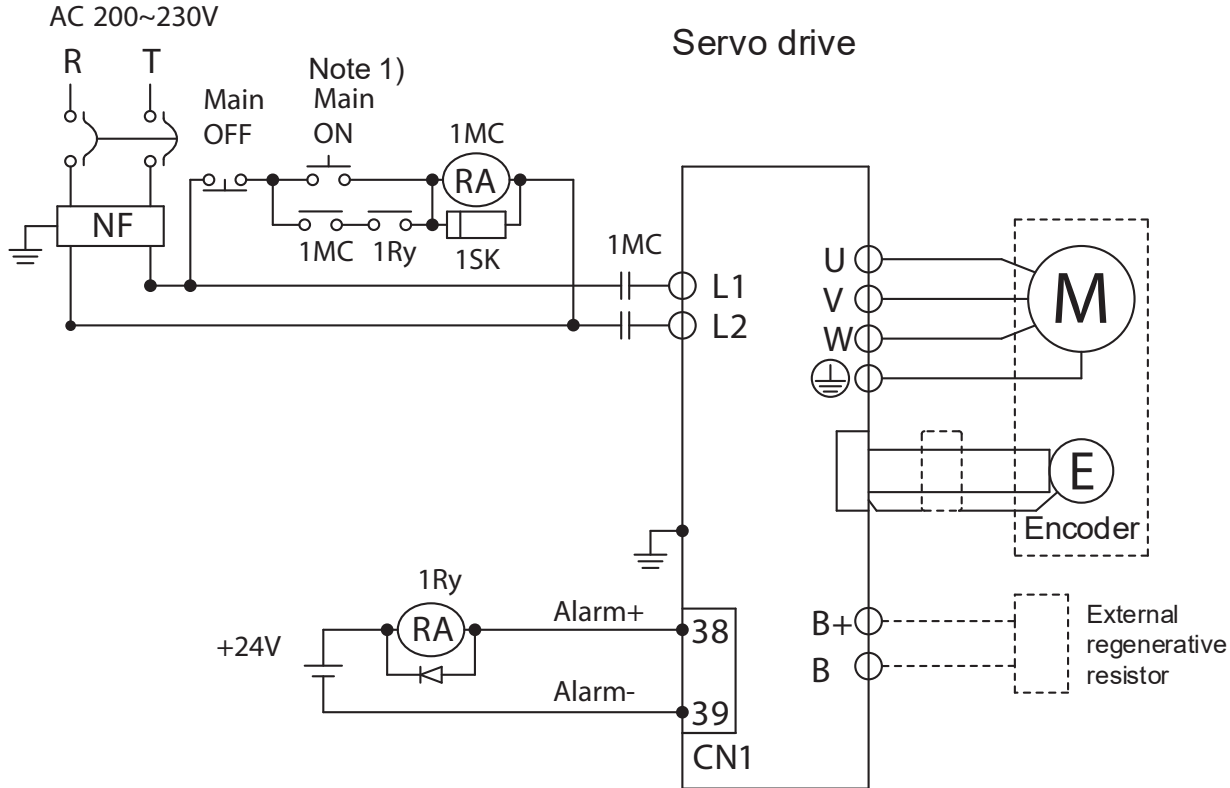

NOTE 1: About 1–2 seconds are required from main power supply to alarm signal output. Hold the main power on for 2 seconds until the alarm circuit (“1Ry”) will latch main power ON.

NOTE: If an external regen resistor is required, connect a regenerative resistance of 50W/100Ω for the L7CA004U-AD, and 100W/40Ω for the L7CA010U-AD.

Connect the L7C RS422 port to a PLC with an RS485 port:

To use RS422 with AutomationDirect PLCs with RS485 ports

PLC RS485 terminals

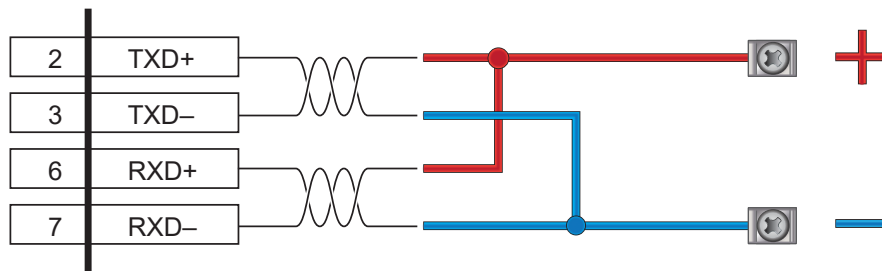

NOTE: Do not use APC-VSCN1T(xx)-AD feedthrough terminal block if using PLC/Drive serial communication. Communication errors may occur due to disconnects in cable shields. Use APC-CN10xA-AD flying lead cables.

LS ELECTRIC L7C Series AC Servo Systems

Non-brake Motor Specifications

L7C Non-brake Motor Specifications					
Model	APMC-FBL01AYK-AD	APMC-FBL02AYK-AD	APMC-FBL04AYK-AD	APMC-FCL08AYK-AD	APMC-FCL10AYK-AD
Price	\$210.00	\$248.00	\$260.00	\$308.00	\$376.00
Drawing	PDF	PDF	PDF	PDF	PDF
Flange Size	60	60	60	80	80
Rated Power [kW]	0.1	0.2	0.4	0.75	1
Rated Torque [N·m] Note 1	0.32	0.64	1.27	2.39	3.18
Max. Torque [N·m]	0.96	1.91	3.82	7.16	9.55
Rated Speed [rpm]	3000				
Max. Speed [rpm]	5000				
Mechanical Time Constant [ms]	0.926	0.518	0.374	0.609	0.492
Rated current [Amps] rms	0.95	1.45	2.6	5.02	5.83
Max. Instantaneous Current [Amps] rms	2.85	4.35	7.8	15.07	17.5
Rated Power Rate [kW/s]	11.09	27.6	27.07	45.09	62.08
Electrical Time Constant [ms]	2.416	3.488	4.271	5.774	6.919
Insulation Class	Class BE (CE, UL)				
Insulation Resistance	>10MΩ, 500VDC				
Insulation Strength	1.8 kVAC, 1 second				
Rotor Inertia [x10 ⁻⁴ kg m ²]	0.091	0.147	0.248	1.264	1.632
Allowable Load Inertia Ratio	20 times motor inertia			15 times motor inertia	
Max Radial Loading [N]	206			255	
Max Axial Loading [N]	69			98	
Vibration Grade [μm]	V15				
Vibration Capacity	19.6m/s ² or lower (2.5G)				

Note 1—The rated torque is the continuous permissible torque between the 0°C and 40°C operating temperature which is suitable for a servo motor mounted with the following heat sink dimensions: 250mm x 250mm x 6mm made from aluminum (or mounted to equipment with an equivalent heat sinking capability).

LS ELECTRIC L7C Series AC Servo Systems

Non-brake Motor Specifications, *continued*

L7C Non-brake Motor Specifications, <i>continued</i>					
Model	<u>APMC-FBL01AYK-AD</u>	<u>APMC-FBL02AYK-AD</u>	<u>APMC-FBL04AYK-AD</u>	<u>APMC-FCL08AYK-AD</u>	<u>APMC-FCL10AYK-AD</u>
Speed/Position Detector	Serial Single-Turn Encoder (17-bit), built-in				
IP Rating	Fully closed, self cooling IP67				
Rated Time	Continuous				
Operating Temperature	0°C to 40°C				
Storage Temperature	-10°C to 60°C				
Operating Humidity	Below 80% relative humidity				
Storage Humidity	Below 90% relative humidity, no condensation				
Atmosphere	Avoid direct sunlight, no corrosive gas, inflammable gas, oil mist, or dust				
E/V	Elevation/vibration 49m/s ² (5G)				
Weight [kg]	0.56	0.74	1.06	2.68	3.3
Agency Approvals	cUR _{US} (E255738), CE				

Note 1—The rated torque is the continuous permissible torque between the 0°C and 40°C operating temperature which is suitable for a servo motor mounted with the following heat sink dimensions: 250mm x 250mm x 6mm made from aluminum (or mounted to equipment with an equivalent heat sinking capability).

LS ELECTRIC L7C Series AC Servo Systems

Brake Motor Specifications

L7C Brake Motor Specifications					
Model	APMC-FBL01AYK2-AD	APMC-FBL02AYK2-AD	APMC-FBL04AYK2-AD	APMC-FCL08AYK2-AD	APMC-FCL10AYK2-AD
Price	\$386.00	\$434.00	\$444.00	\$484.00	\$569.00
Drawing	PDF	PDF	PDF	PDF	PDF
Flange Size	60	60	60	80	80
Rated Power [kW]	0.1	0.2	0.4	0.75	1
Rated Torque [N·m] Note 1	0.32	0.64	1.27	2.39	3.18
Max. Torque [N·m]	0.96	1.91	3.82	7.16	9.55
Rated Speed [rpm]	3000				
Max. Speed [rpm]	5000				
Mechanical Time Constant [ms]	0.926	0.518	0.374	0.609	0.492
Rated current [Amps] rms	0.95	1.45	2.6	5.02	5.83
Max. Instantaneous Current [Amps] rms	2.85	4.35	7.8	15.07	17.5
Rated Power Rate [kW/s]	11.09	27.6	27.07	45.09	62.08
Electrical Time Constant [ms]	2.416	3.488	4.271	5.774	6.919
Insulation Class	Class BE (CE, UL)				
Insulation Resistance	>10MΩ, 500VDC				
Insulation Strength	1.8 kVAC, 1 second				
Rotor Inertia [x10 ⁻⁴ kg m ²]	0.091	0.147	0.248	1.264	1.632
Allowable Load Inertia Ratio	20 times motor inertia			15 times motor inertia	
Max Radial Loading [N]	206			255	
Max Axial Loading [N]	69			98	
Brake Holding Torque [N·m (min)]	1.47			3.23	
Brake Power Consumption (at 20°C) [W]	6.5			9	
Brake Release Time [ms (max)]	20				
Brake Pull-in Time [ms (max)]	50			60	
Vibration Grade [μm]	V15				
Vibration Capacity	19.6m/s ² or lower (2.5G)				

Note 1—The rated torque is the continuous permissible torque between the 0°C and 40°C operating temperature which is suitable for a servo motor mounted with the following heat sink dimensions: 250mm x 250mm x 6mm made from aluminum (or mounted to equipment with an equivalent heat sinking capability).

LS ELECTRIC L7C Series AC Servo Systems

Brake Motor Specifications, *continued*

L7C Brake Motor Specifications, <i>continued</i>					
Model	APMC-FBL01AYK2-AD	APMC-FBL02AYK2-AD	APMC-FBL04AYK2-AD	APMC-FCL08AYK2-AD	APMC-FCL10AYK2-AD
Speed/Position Detector	Serial Multi-Turn Built-in Type (17-bit)				
IP Rating	Fully closed, self cooling IP67				
Rated Time	Continuous				
Operating Temperature	0°C to 40°C				
Storage Temperature	-10°C to 60°C				
Operating Humidity	Below 80% relative humidity				
Storage Humidity	Below 90% relative humidity, no condensation				
Atmosphere	Avoid direct sunlight, no corrosive gas, inflammable gas, oil mist, or dust				
E/V	Elevation/vibration 49m/s ² (5G)				
Weight [kg]	1.28	1.46	1.78	3.45	4.07
Agency Approvals	cUR _{US} (E255738), CE				

Note 1—The rated torque is the continuous permissible torque between the 0°C and 40°C operating temperature which is suitable for a servo motor mounted with the following heat sink dimensions: 250mm x 250mm x 6mm made from aluminum (or mounted to equipment with an equivalent heat sinking capability).



L7P Series AC Servo Systems

Drive features

- Power: 100W–7.5 kW three-phase 230VAC/460VAC
100W–2.2 kW single-phase 230VAC capable
- Fully digital control with up to 1kHz velocity loop response
- Easy setup and diagnostics with DriveCM PC-based software
- Field upgradeable firmware ensures the drive can always be upgraded to the latest operating system
- Command options include:
 - $\pm 10V$ torque or velocity command
 - Pulse train or master encoder position command (accepts line driver or open collector)
 - Internal Indexer for position/speed-based moves include the option for simple registration correction. 64 individual move statements can be configured in the drive. Each Index contains its own distance, speed, accel, decel, and dwell parameters. These indexes can be set up through DriveCM software or modified in real-time with serial communication (PLC, HMI, etc.). The indexes can be initiated via Digital Inputs or through serial comms.
- The 1 kHz bandwidth allows for high-level automatic tuning. Several modes of tuning are available including Off-Line Auto Tuning (the drive initiates its own move commands while Auto tuning), On-Line Auto Tuning (an external controller sends the move commands while the drive Auto tunes), and Manual Tuning (all tuning values are adjusted by the user).
- (16) Optically isolated digital inputs and (8) general purpose (user configurable) outputs, analog inputs for speed and torque control (2), and line driver and open collector output for encoder (with scalable resolution). Two configurable analog outputs for monitoring various servo parameters (actual speed, torque, current, position, etc.)
- Advanced Scope feature that can monitor a variety of command and status signals, including output speed, torque, power, etc.



Motor features

- Low and Medium inertia motors available:
 - Low: 100W, 200W, 400W, 750W, 900W, 1kW, and 1.5 kW; @5000rpm
 - Medium: 1.6 kW, 2.2 kW, 3.5 kW, 5.5 kW, and 7.5 kW; @3000rpm
- Permanent magnet 3-phase synchronous motor
- Keyed drive shafts support clamp-on style couplings or key-style couplings
- Integrated multi-turn absolute encoder with 19-bit resolution (524,288 pulses per revolution)
- Optional 24 VDC spring-set holding brakes (AMK2 and DMK2 motors)
- Standard hook-up cables for motor power, encoder, and brake (separate brake cable for FBL/FCL brake motors)
- Motor cables available in standard or flex-rated lengths of 3, 5, 10, and 20m
- Standard 50-pin DIN-rail mounted break-out kit for the drive's CN1 connector (with screw terminal connections), or 50-pin cables with flying leads

Note: These parts available for sale to North American locations only.

Tuning Technology

The L7P drive closes the loop on current, velocity, and position (depending on control mode selection). The 1kHz bandwidth in the drive assures precise speed and current control and easy tuning. Proportional gain, integral gain and compensation, feed forward compensation, command low pass filter, and four (4) notch filters for resonance suppression are available. Auto Tuning has been greatly improved and can tune motors up to 20:1 inertia mismatch.

There is an inertia estimation function that analyzes the motor and load to measure how much inertia is coupled to the motor.

The drive has several tuning methods available:

- Online Auto Tuning—the drive can either tune the load live while an external controller moves the load to different positions or using the drive's internal tuning motion profile.
- Offline Auto Tuning—the drive tunes the load using the drive's internal tuning motion profile.
- Manual Tuning—all parameters are available to give power users the ultimate flexibility to tune their systems.

Built-in Indexer

While the L7P drives can accept traditional commands from host controllers, they can also provide their own internal motion control. 64 point-to-point position moves can be configured in the drive. These moves can be populated through the DriveCM configuration software or they can be written to by a PLC through the drive's RS422/485 serial port. The moves can be initiated by digital inputs or by serial commands and include the ability to handle simple registration, and can be sequenced internally with delays in between the moves or moves can be linked together so they are processed one after the other.

Multi-axis systems can be controlled via digital inputs, or serial communication. The motion can be commanded from a powerful external controller that sends out high speed pulses to each drive, or the motion can be initiated by a low-level controller (the simplest CLICK PLC) since each drive has a powerful indexer inside. Applications include press feeds, auger fillers, rotary tables, robots for pick and place, test or assembly operations, drilling, cutting, tapping, and similar applications using simple index moves for single or multi-axis motion.

Optional Holding Brake

Each L7P motor can be ordered with an optional 24VDC spring-set holding brake that holds the motor in place when power is removed.

LS Electric MSS Series In-Line Planetary Precision Gearboxes for Servo Motors

Need more torque from the motor? Have an inertia balancing issue in your design? The LS Electric MSS series gearboxes easily mate to FBL/FCL/FE/FF motors. Everything you need for mounting is included!

- Three gear ratios available (5:1, 10:1, 20:1*)
- Mounting hardware included for attaching to FBL/FCL/FE/FF motors.
- Industry-standard mounting dimensions
- Thread-in mounting style
- Very low backlash: 7 arc-min single stage (5:1 and 10:1 ratios), 9 arc-min two-stage (20:1 ratios*).
- 1-year warranty



** The available gearbox ratios for the 7.5 kW motors are 5:1, 10:1, and 15:1, but the features are otherwise equivalent.*



L7P Series AC Servo Systems

Servo drive overview

DC Bus Charge LED

Visual indication of the drive's DC bus voltage level. Do not work on the drive until the Charge LED is OFF.

Motor Power Terminal

Incoming single or three phase 200-230 VAC or three phase 380-480 VAC, model dependent. (-15% to +10%, 50/60Hz)

Regenerative Resistor Terminal

Connection for optional external braking resistor

Control Power Terminal

Incoming single phase 200-230 VAC (or 380-480 VAC for "PB" models)(-15% to +10%, 50/60Hz)

Motor Output Terminal

Output power to the servo motor. LS motor power cables available in 3, 5, 10, and 20 meter lengths in standard and flexing cables.

Model Number

Clearly displayed on bottom of drive face for easy identification.

LED Display

The 5-digit display is used to indicate servo status and alarm.

DIPswitch #2

120Ω terminating resistor for the RS422/RS485 network (use at the end of a multi-drop network)

Analog Connector

4-pin analog monitoring connector (two +/- 10V analog outputs). See L7P-CON-F and L7P-CON-G for optional connectors

Rotary DIPswitch (0-15)

Sets RS422/485 comms station ID. Switch #3 adds 16 to the Node ID (so total addressable Node IDs = 0-31)

USB Connector

Used by Drive CM software for servo configuration. Connect with a standard USB A to USB mini-B cable (SV2-PGM-USB15, MOSAIC-CSU, or similar).

Firmware Upgrade: Use DriveCM software or attach a USB thumb drive with the new FW and update using USB On the Go (no PC required). See the UM for details.

RJ45 Connectors

Serial Modbus RS422 (compatible with RS485 PLCs). Use standard ethernet cables (not crossover cables) to connect multiple drives in a serial network.

CN1 I/O Signal Connector

50-pin CN1 connector for drive I/O. Signals include high speed pulse inputs, 16 digital inputs, 8 digital outputs, 2 analog inputs (voltage and torque), and scalable encoder output.

Encoder Connector

14-pin CN2 connector for the motor encoder. LS Encoder cables available in 3, 5, 10, and 20 meter lengths in standard and flexing cables.



The LS Electric L7P servo drives are fully digital and include over 300 parameters to configure the drive for almost any application. For convenience, the parameters are grouped into several categories including:

- Basic parameters
- Gain parameters
- I/O parameters
- Velocity parameters
- Misc. parameters
- Monitor parameters
- Index parameters

All parameters have commonly used default values which allow you to operate the L7P drive "out-of-the-box". The drive auto-detects the

LS servo motor (through the serial encoder) and sets up the default gains and limits based on the connected motor.

The drive can still be easily configured to your specific application, however. The Drive CM configuration software has a built-in Setup Wizard that will guide you through all the basic setup parameters. So, whether you want to use high speed pulse input, analog velocity, analog torque, or the powerful internal indexer for a control mode (or any multi-mode combination of these modes), the Setup Wizard will quickly and easily get your application started – from setting up the I/O to determining the appropriate homing sequence.

After configuration is complete, the Auto Tune features of the drive will get your application tuned for optimal responsiveness and performance.



L7P/iX7NH AC Servo Systems

Servo motor overview

Encoder Connector

9-pin watertight connector for the 19-bit serial encoder. The encoder transmits motor/encoder identification information to the drive at power-up and it sends position feedback during operation.

Brake Power Connector

2-pin watertight connector available on FBL/FCL brake motors only. The 24VDC brake is located between the motor coils and the encoder. Motors ending in AMK2 and DMK2 have brakes. The brakes must have 24VDC applied to them before the motor is set in motion.

Low Inertia Motors

Low inertia designs (AMK series) result in high responsiveness at high speeds for lighter loads.

- 100–100W motors available
- 60 and 80 mm flanges

FBL/FCL Series Motor

Motor Power Connector

4-pin watertight connector for motor power (U, V, W, and ground)



IP67 Housing

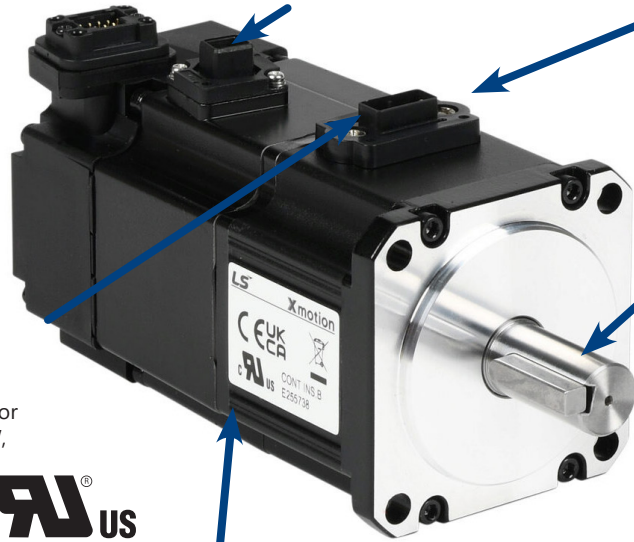

Keyed Shafts

FBL and FCL motors are supplied with extra-large keyways, and slightly oversized keys which may need to be "fitted" into the keyway for performance and longevity. Clamp or compression couplings (without key) are recommended.

- 100W 14mm diameter shaft
- 200W 14mm diameter shaft
- 400W 14mm diameter shaft
- 750W 19mm diameter shaft
- 1000W 19mm diameter shaft

All LS Electric FBL/FCL/FE/FF motors have keyed shafts for use with servo-grade clamp or compression couplings (recommended) or servo-grade keyed couplings. Some sanding/filing of the key may be required before pressing into the keyway. Do not modify the shaft/keyway.

Encoder Connector

17-pin watertight connector for the 19-bit serial encoder. The encoder transmits motor/encoder identification information to the drive at power-up and it sends position feedback during operation.

Low and Medium Inertia Motors

Low inertia designs (AMK series) result in high responsiveness at high speeds for lighter loads.

- 1500W motors with 130mm flanges available

Medium inertia designs (DMK series) result in high responsiveness at moderate speeds for heavier loads.

- 1600–7500W motors available
- 130 and 180 mm flanges

FE/FF Series Motor

Motor Power Connector

4-pin watertight connector for motor power (U, V, W, and ground). For brake models, also supports brake wiring.



IP65 Housing

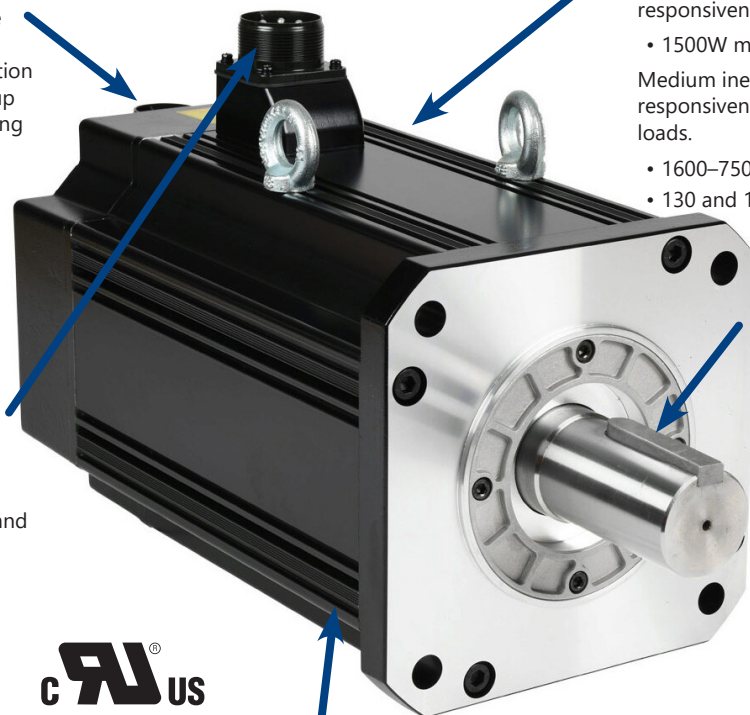

Keyed Shafts

FE and FF motors are supplied with extra-large keyways, and slightly oversized keys which may need to be "fitted" into the keyway for performance and longevity. Clamp or compression couplings (without key) are recommended.

- 900W 19mm diameter shaft
- 1500W 19mm diameter shaft
- 1600W 22mm diameter shaft
- 2200W 24mm diameter shaft
- 3500W 35mm diameter shaft
- 5500W 35mm diameter shaft
- 7500W 42mm diameter shaft

How to select and apply L7P systems

The primary purpose of the AC servo system is to precisely control the motion of the load. The most fundamental considerations in selecting the servo system are “reflected” load inertia, servo system maximum speed requirement, servo system continuous torque requirement, and servo system peak torque requirement. In a retrofit application, select the largest torque servo system that most closely matches these parameters for the system being replaced. In a new application, these parameters should be determined through calculation and/or

measurement. The Drive CM software has the ability to measure the load (reflected) inertia and accurately measure the motor torque output.

AutomationDirect has teamed with Copperhill Technologies to provide free servo-sizing software. “VisualSizer-SureServo” software will assist in determining the correct motor and drive for your application by calculating the reflected load inertia and required speed and torque based on the load configuration. “VisualSizer-SureServo” software can be downloaded from <https://support.automationdirect.com/products/lselectric.html>.

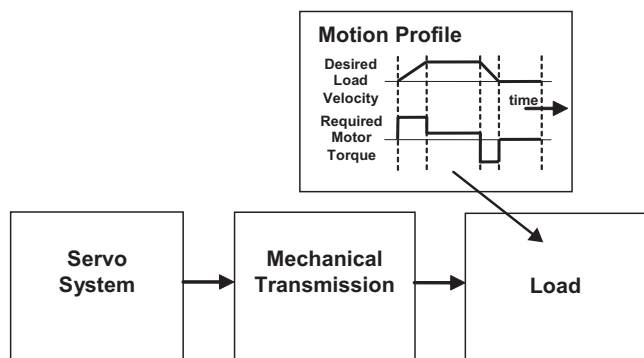

1. “Reflected” load inertia

The inertia of everything attached to the servo motor driveshaft needs to be considered and the total “reflected” inertia needs to be determined. This means that all elements of any mechanical transmission and load inertia need to be translated into an equivalent inertia as if attached directly to the motor driveshaft. The ratio of “reflected” load inertia to motor inertia needs to be carefully considered when selecting the servo system.

In general, applications that need high response or bandwidth

will benefit from keeping the ratio of load inertia to motor inertia as low as possible and ideally under 10:1. L7P Auto Tuning will still tune a system with very high response, up to 20:1 inertia mismatch. Higher system ratios can be implemented, but corresponding lower bandwidth or responsiveness must be accepted. The servo response including the attached load inertia is determined by the servo tuning. The L7P servo systems may be tuned automatically by the software/drive or manually by the user.

2. Torque and speed

With knowledge of the motion profile and any mechanical transmission between the motor and load, calculations can be made to determine the required servo motor continuous torque, peak torque, and maximum motor speed. The required amount of continuous torque must fall inside the continuous operating region of the system torque-speed curve (you can check the continuous torque at the average speed of the motion profile). The required amount of peak torque must also fall within the servo system’s intermittent operating region of the system torque-speed curve (you need to check this value at the required maximum speed or torque). If you have an L7P system, these values are easily captured and recorded with the Scope feature built into the Drive CM software. If you are designing the system from scratch, use VisualSizer to define the system and calculate expected inertia and required power.

Compare the application’s Continuous and Intermittent torque requirements to the torque-speed curves found in Chapter 16 of the L7P User Manual or in the system torque charts found on “L7P AC servo drive, motor, and cable combinations” on page tSRV-28.

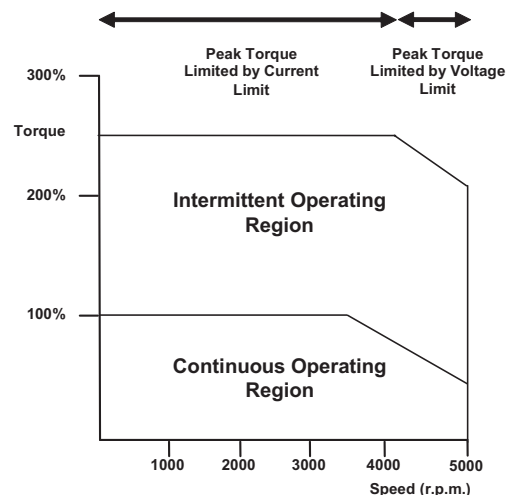

Application tip - coupling considerations

The LS Electric FBL/FCL motors have keyed shafts that can be used with keyed couplings or with clamp-on or compression style couplings. For standard keyed couplings, the servo key must be "fitted" into the keyway for optimum performance and longevity. Some minor filing and pressing of the key may be required. "Servo-grade" clamp-on or compression style couplings

are usually the best choice when you consider stiffness, torque rating, and inertia. Higher stiffness (lb-in/radian) is needed for better response but there is a trade-off between stiffness and the added inertia of the coupling. Concerning the torque rating of the coupling, use a safety factor of 1.25 over the servo's **peak** torque requirement of your application.

[Click here for Available Couplings](#)

Mechanical transmissions

Common mechanical transmissions include leadscrews, rack & pinion mechanisms, conveyors, gears, and timing belts. The use of leadscrew, rack & pinion, or conveyor are common ways to translate the rotary motion of the servo motor into linear motion of the load. Matched gearboxes are available from LS Electric that will work with the LS servo motors. Each gearbox is selected to accept the 300% maximum available torque that could be generated by the motor. Gearboxes are available in 5:1, 10:1, and 20:1 ratios. The use of a speed reducer such as a gearbox or timing belt can be very beneficial as follows:

1. Reduction of reflected load inertia

As a general rule, keep the reflected load inertia as low as possible while using the full range of servo speed. The LS Electric motors can rotate at a rated speed of 2000 or 3000 rpm (rated torque at rated speed). Their max speed (slightly less available torque) is 3000 or 5000 rpm. See the speed-torque curves for more information.

Example: A gearbox reduces the motor's required torque by a factor of the gear ratio, and reduces the reflected load inertia by a factor of the gear ratio squared. A 10:1 gearbox reduces output speed to 1/10, increases output torque 10 times, and decreases reflected inertia to 1/100.

However, when investigating the effect of different speed reduction ratios DO NOT forget to include the added inertia of couplings, gearbox, or timing belt pulleys. These added inertias can be significant, and can negate any inertia reduction due to the speed reduction.

[Here is a link to our Timing Belts and Pulleys](#)

Ordering guide instructions

The following four pages are your ordering guide for LS Electric L7P servo systems. Each system has a torque-speed curve included for reference. This is the fundamental information that you need to select the servo motor and matching drive for your application.

Each system needs:

- Motor
- Drive
- Motor Power Cable
- Motor Encoder Cable
- I/O connections (either a 50-pin CN1 cable+terminals kit or a 50-pin flying lead cable(user provides terminal blocks))
- FBL/FCL brake motors require a brake cable. FE/FF brake motors have brake wiring included in the power cable.

2. Low speed and high torque applications

If the application requires low speed and high torque then it is common to introduce a speed reducer so that the servo system can operate over more of the available speed range. This could also have the added benefit of reducing the servo motor torque requirement which could allow you to use a smaller and lower cost servo system. Additional benefits are also possible with reduction in reflected inertia, increased number of motor encoder counts at the load, and increased ability to reject load disturbances due to mechanical advantage of the speed reducer.

3. Space limitations and motor orientation

LS Electric servo motors can be mounted in any orientation, but the shaft seal should not be immersed in oil (open-frame gearbox, etc.). Reducers can possibly allow the use of a smaller motor or allow the motor to be repositioned.



Motor	Brake Motor	LS Electric MSS Planetary In-Line Gearboxes		
		5:1 Gearbox	10:1 Gearbox	20:1 Gearbox
APMC-FBL01AMK-AD	APMC-FBL01AMK2-AD			
APMC-FBL02AMK-AD	APMC-FBL02AMK2-AD	96200004	96200005	96200103
APMC-FBL04AMK-AD	APMC-FBL04AMK2-AD			
APMC-FCL08AMK-AD	APMC-FCL08AMK2-AD			
APMC-FCL10AMK-AD	APMC-FCL10AMK2-AD	96200007	96200008	96200257
APM-FEP09AMK-AD	APM-FEP09AMK2-AD			
APM-FE15AMK-AD	APM-FE15AMK2-AD	96200373	96200378	96200393
APM-FEP15AMK-AD	APM-FEP15AMK2-AD			
APM-FE16DMK-AD	APM-FE16DMK2-AD			
APM-FEP16DMK-AD	APM-FEP16DMK2-AD	96200459	96200464	96200479
APM-FE22DMK-AD	APM-FE22DMK2-AD			
APM-FEP22DMK-AD	APM-FEP22DMK2-AD	96200010	96200011	96200445
APM-FF35DMK-AD	APM-FF35DMK2-AD			
APM-FFP35DMK-AD	APM-FFP35DMK2-AD			
APM-FF55DMK-AD	APM-FF55DMK2-AD	96200013	96200014	96200701
APM-FFP55DMK-AD	APM-FFP55DMK2-AD			
APM-FF75DMK-AD	APM-FF75DMK2-AD			
APM-FFP75DMK-AD	APM-FFP75DMK2-AD	96200016	96200017	96200862 (15:1 gear ratio)

L7P series drives and motors part numbering system

Drives

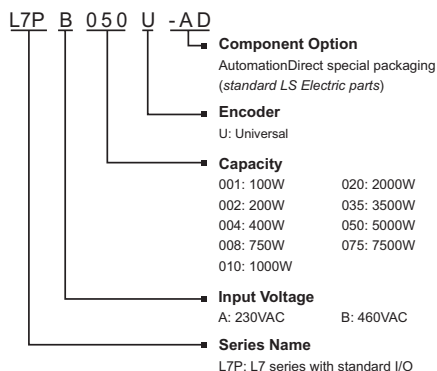

Motors

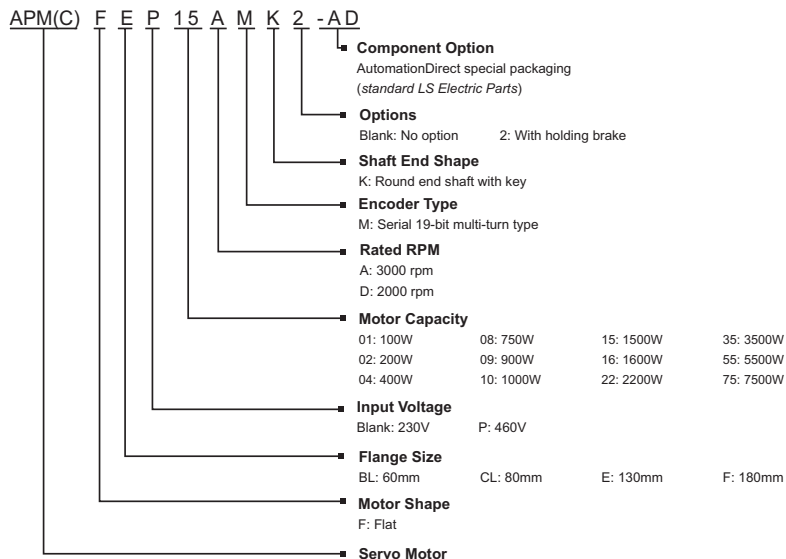

Example of what you will need to build a complete servo system:

Servo Drive

+

Servo Motor

+

Motor Power Cable

+

Motor Encoder Cable

+

I/O Interface

Completed motor assembly (with optional gearbox)

NOTE: AMPC-FBL/FCL brake equipped motors will also require a separate brake power cable.

NOTE: Unit can be programmed via keypad. Optional programming software (free download). Use a standard USB-A to USB miniB cable for connectivity (SV2-PGM-USB15, MOSAIC-CSU, or equivalent)

NOTE: If you need a gear box for your configuration, reference the gearbox chart on the previous page. Ratios of 5:1, 10:1, and 20:1 are available for each motor.





L7P Series AC Servo Systems

Torque to L7P System Quick Reference

Input Voltage	System Rated Torque (N·m)	System Maximum Torque (N·m)	Suggested Servo Motor	Required Servo Drive	
230VAC	0.32	0.96	APMC-FBL01AMK-AD	L7PA004U-AD	
			APMC-FBL01AMK2-AD		
	0.64	1.91	APMC-FBL02AMK-AD		L7PA004U-AD
			APMC-FBL02AMK2-AD		
	1.27	3.82	APMC-FBL04AMK-AD		L7PA004U-AD
			APMC-FBL04AMK2-AD		
	2.39	7.16	APMC-FCL08AMK-AD	L7PA010U-AD*	
			APMC-FCL08AMK2-AD		
	3.10	9.55	APMC-FCL10AMK-AD		
	230VAC	4.77	14.32	APMC-FCL10AMK2-AD	L7PA010U-AD*
				APMC-FCL10AMK2-AD	
		7.63	22.92	APM-FE15AMK-AD	
				APM-FE15AMK2-AD	
		10.5	31.51	APM-FE16DMK-AD	L7PA020U-AD
APM-FE16DMK2-AD					
16.7		50.1	APM-FE22DMK-AD	L7PA020U-AD	
			APM-FE22DMK2-AD		
26.25		78.76	APM-FF35DMK-AD	L7PA035U-AD	
			APM-FF35DMK2-AD		
35.81	89.53	APM-FF55DMK-AD	L7PA050U-AD		
		APM-FF55DMK2-AD			
35.81	89.53	APM-FF75DMK-AD	L7PA075U-AD		
		APM-FF75DMK2-AD			
460VAC	2.86	8.59	APM-FEP09AMK-AD	L7PB010U-AD	
			APM-FEP09AMK2-AD		
	4.77	14.32	APM-FEP15AMK-AD	L7PB020U-AD	
			APM-FEP15AMK2-AD		
	7.64	22.92	APM-FEP16DMK-AD		L7PB020U-AD
			APM-FEP16DMK2-AD		
	10.5	31.51	APM-FEP22DMK-AD	L7PB020U-AD	
			APM-FEP22DMK2-AD		
	16.71	50.13	APM-FFP35DMK-AD	L7PB035U-AD	
			APM-FFP35DMK2-AD		
	26.26	65.65	APM-FFP55DMK-AD	L7PB050U-AD	
			APM-FFP55DMK2-AD		
	35.81	89.52	APM-FFP75DMK-AD	L7PB075U-AD	
			APM-FFP75DMK2-AD		

* 1kW motors only: For single-phase supply, derate motor max torque to 200% or upsize the drive to L7PA020U-AD for max motor torque.
** 2.2 kW motors only: For single-phase supply, upsize the drive to L7PA035U-AD for max motor torque.



L7P Series AC Servo Systems

L7P AC servo drive, motor, and cable combinations

xx = Cable length in meters
 BN/EN/PN = Standard cable (not continuous flex)
 BF/EF/PF = Flex-rated cable

AMK/DMK motors = no brake
 AMK2/DMK2 motors = mechanical holding brake

230V FBL/FCL Motor Systems

Type	System Torque Chart	L7P Drive	APM/APMC Motor	Power Cable	Encoder Cable	Brake Cable	I/O Cable and Breakout
100W Low Inertia System		L7PA004U-AD	APMC-FBL01AMK-AD	APCS-PNxxLS-AD	APCS-ENxxxES1-AD	n/a	APC-VSCN1Tx-AD or APC-CN10xA-AD
				APCS-PFxxLS-AD	APCS-EFxxxES1-AD		
			APMC-FBL01AMK2-AD	APCS-PNxxLS-AD	APCS-ENxxxES1-AD	APCS-BNxxQS-AD	
				APCS-PFxxLS-AD	APCS-EFxxxES1-AD	APCS-BFxxQS-AD	
200W Low Inertia System		L7PA004U-AD	APMC-FBL02AMK-AD	APCS-PNxxLS-AD	APCS-ENxxxES1-AD	n/a	
				APCS-PFxxLS-AD	APCS-EFxxxES1-AD		
			APMC-FBL02AMK2-AD	APCS-PNxxLS-AD	APCS-ENxxxES1-AD	APCS-BNxxQS-AD	
				APCS-PFxxLS-AD	APCS-EFxxxES1-AD	APCS-BFxxQS-AD	
400W Low Inertia System		L7PA004U-AD	APMC-FBL04AMK-AD	APCS-PNxxLS-AD	APCS-ENxxxES1-AD	n/a	
				APCS-PFxxLS-AD	APCS-EFxxxES1-AD		
			APMC-FBL04AMK2-AD	APCS-PNxxLS-AD	APCS-ENxxxES1-AD	APCS-BNxxQS-AD	
				APCS-PFxxLS-AD	APCS-EFxxxES1-AD	APCS-BFxxQS-AD	
750W Low Inertia System		L7PA010U-AD	APMC-FCL08AMK-AD	APCS-PNxxLS-AD	APCS-ENxxxES1-AD	n/a	
				APCS-PFxxLS-AD	APCS-EFxxxES1-AD		
			APMC-FCL08AMK2-AD	APCS-PNxxLS-AD	APCS-ENxxxES1-AD	APCS-BNxxQS-AD	
				APCS-PFxxLS-AD	APCS-EFxxxES1-AD	APCS-BFxxQS-AD	



L7P Series AC Servo Systems

L7P AC servo drive, motor, and cable combinations, *continued*

xx = Cable length in meters

BN, EN, or PN = Standard cable (not continuous flex)

BF, EF, or PF = Flex-rated cable

AMK/DMK motors = no brake

AMK2/DMK2 motors = mechanical holding brake

Type	System Torque Chart	L7P Drive	APMC Motor	Power Cable	Encoder Cable	Brake Cable	I/O Cable and Breakout
1.0k W Low Inertia System		L7PA010U-AD	APMC-FCL10AMK-AD	APCS-PNxxxLS-AD	APCS-ENxxxES1-AD	n/a	APC-VSCN1Txx-AD or APC-CN10xA-AD
				APCS-PFxxxLS-AD	APCS-EFxxxES1-AD		
			APMC-FCL10AMK2-AD	APCS-PNxxxLS-AD	APCS-ENxxxES1-AD	APCS-BNxxQS-AD	
				APCS-PFxxxLS-AD	APCS-EFxxxES1-AD	APCS-BFxxQS-AD	

* Note - For single-phase supply, derate motor max torque to 200%, or upsize the drive to L7PA020U-AD for the torque curves in the graph.

230V FE Motor Systems

Type	System Torque Chart	L7P Drive	APM/APMC Motor	Power Cable**	Encoder Cable	I/O Cable and Breakout
1.5 kW Low Inertia System		L7PA020U-AD***	APM-FE15AMK-AD	APCS-PNxxHS-AD	APCS-ENxxxDS1-AD	APC-VSCN1Txx-AD or APC-CN10xA-AD
				APCS-PFxxHS-AD	APCS-EFxxxDS1-AD	
			APM-FE15AMK2-AD	APCS-PNxxNB-AD	APCS-ENxxxDS1-AD	
				APCS-PFxxNB-AD	APCS-EFxxxDS1-AD	
1.6 kW Medium Inertia System		L7PA020U-AD***	APM-FE16DMK-AD	APCS-PNxxHS-AD	APCS-ENxxxDS1-AD	APC-VSCN1Txx-AD or APC-CN10xA-AD
				APCS-PFxxHS-AD	APCS-EFxxxDS1-AD	
			APM-FE16DMK2-AD	APCS-PNxxNB-AD	APCS-ENxxxDS1-AD	
				APCS-PFxxNB-AD	APCS-EFxxxDS1-AD	
2.2 kW Medium Inertia System		L7PA020U-AD***	APM-FE22DMK-AD	APCS-PNxxHS-AD	APCS-ENxxxDS1-AD	APC-VSCN1Txx-AD or APC-CN10xA-AD
				APCS-PFxxHS-AD	APCS-EFxxxDS1-AD	
			APM-FE22DMK2-AD	APCS-PNxxNB-AD	APCS-ENxxxDS1-AD	
				APCS-PFxxNB-AD	APCS-EFxxxDS1-AD	

** Note - Power cables with "B" in the part number are combination power/brake cables, providing power for both the motor and the brake. A brake cable is not required.

*** Note - For single-phase supply, upsize the drive to L7PA035U-AD for the torque curves in the graph.



L7P Series AC Servo Systems

L7P AC servo drive, motor, and cable combinations, *continued*

xx = Cable length in meters
 BN, EN, or PN = Standard cable (not continuous flex)
 BF, EF, or PF = Flex-rated cable

AMK/DMK motors = no brake
 AMK2/DMK2 motors = mechanical holding brake

230V FF Motor Systems

Type	System Torque Chart	L7P Drive	APM/APMC Motor	Power Cable*	Encoder Cable	I/O Cable and Breakout
3.5 kW Medium Inertia System		L7PA035U-AD	APM-FF35DMK-AD	APCS-PNxxIS-AD	APCS-ENxxxDS1-AD	APC-VSCN1Txx-AD or APC-CN10xA-AD
				APCS-PFxxIS-AD	APCS-EFxxxDS1-AD	
			APM-FF35DMK2-AD	APCS-PNxxPB-AD	APCS-ENxxxDS1-AD	
				APCS-PFxxPB-AD	APCS-EFxxxDS1-AD	
5.5 kW Medium Inertia System		L7PA050U-AD	APM-FF55DMK-AD	APCS-PNxxJS-AD	APCS-ENxxxDS1-AD	
				APCS-PFxxJS-AD	APCS-EFxxxDS1-AD	
			APM-FF55DMK2-AD	APCS-PNxxLB-AD	APCS-ENxxxDS1-AD	
				APCS-PFxxLB-AD	APCS-EFxxxDS1-AD	
7.5 kW Medium Inertia System		L7PA075U-AD	APM-FF75DMK-AD	APCS-PNxxJS2-AD	APCS-ENxxxDS1-AD	
				APCS-PFxxJS2-AD	APCS-EFxxxDS1-AD	
			APM-FF75DMK2-AD	APCS-PNxxLB2-AD	APCS-ENxxxDS1-AD	
				APCS-PFxxLB2-AD	APCS-EFxxxDS1-AD	

*Note - Power cables with "B" in the part number are combination power/brake cables, providing power for both the motor and the brake. A brake cable is not required.



L7P Series AC Servo Systems

L7P AC servo drive, motor, and cable combinations, *continued*

xx = Cable length in meters
 BN, EN, or PN = Standard cable (not continuous flex)
 BF, EF, or PF = Flex-rated cable

AMK/DMK motors = no brake
 AMK2/DMK2 motors = mechanical holding brake

460V FEP Motor Systems

Type	System Torque Chart	L7P Drive	APM/APMC Motor	Power Cable*	Encoder Cable	I/O Cable and Breakout
1kW Low Inertia System		L7PB010U-AD	APM-FEP09AMK-AD	APCS-PNxxHS-AD	APCS-ENxxxDS1-AD	APC-VSCN1Txx-AD or APC-CN10xA-AD
				APCS-PFxxHS-AD	APCS-EFxxxDS1-AD	
			APM-FEP09AMK2-AD	APCS-PNxxNB-AD	APCS-ENxxxDS1-AD	
				APCS-PFxxNB-AD	APCS-EFxxxDS1-AD	
1.5 kW Low Inertia System		L7PB020U-AD	APM-FEP15AMK-AD	APCS-PNxxHS-AD	APCS-ENxxxDS1-AD	
				APCS-PFxxHS-AD	APCS-EFxxxDS1-AD	
			APM-FEP15AMK2-AD	APCS-PNxxNB-AD	APCS-ENxxxDS1-AD	
				APCS-PFxxNB-AD	APCS-EFxxxDS1-AD	
1.6 kW Medium Inertia System		L7PB020U-AD	APM-FEP16DMK-AD	APCS-PNxxHS-AD	APCS-ENxxxDS1-AD	
				APCS-PFxxHS-AD	APCS-EFxxxDS1-AD	
			APM-FEP16DMK2-AD	APCS-PNxxNB-AD	APCS-ENxxxDS1-AD	
				APCS-PFxxNB-AD	APCS-EFxxxDS1-AD	
2.2 kW Medium Inertia System		L7PB020U-AD	APM-FEP22DMK-AD	APCS-PNxxHS-AD	APCS-ENxxxDS1-AD	
				APCS-PFxxHS-AD	APCS-EFxxxDS1-AD	
			APM-FEP22DMK2-AD	APCS-PNxxNB-AD	APCS-ENxxxDS1-AD	
				APCS-PFxxNB-AD	APCS-EFxxxDS1-AD	

*Note - Power cables ending in "B-AD" are combination power/brake cables, and provide power for both the motor and the brake. A separate brake cable is not required.



L7P Series AC Servo Systems

L7P AC servo drive, motor, and cable combinations, *continued*

xx = Cable length in meters
 BN, EN, or PN = Standard cable (not continuous flex)
 BF, EF, or PF = Flex-rated cable

AMK/DMK motors = no brake
 AMK2/DMK2 motors = mechanical holding brake

460V FFP Motor Systems

Type	System Torque Chart	L7P Drive	APM/APMC Motor	Power Cable*	Encoder Cable	I/O Cable and Breakout
3.5 kW Medium Inertia System		L7PB035U-AD	APM-FFP35DMK-AD	APCS-PNxxIS-AD	APCS-ENxxxDS1-AD	
				APCS-PFxxIS-AD	APCS-EFxxxDS1-AD	
			APM-FFP35DMK2-AD	APCS-PNxxPB-AD	APCS-ENxxxDS1-AD	
				APCS-PFxxPB-AD	APCS-EFxxxDS1-AD	
5.5 kW Medium Inertia System		L7PB050U-AD	APM-FFP55DMK-AD	APCS-PFxxJS1-AD**	APCS-ENxxxDS1-AD	APC-VSCN1Txx-AD or APC-CN10xA-AD
				APCS-PFxxJS1-AD	APCS-EFxxxDS1-AD	
			APM-FFP55DMK2-AD	APCS-PFxxLB1-AD**	APCS-ENxxxDS1-AD	
				APCS-PFxxLB1-AD	APCS-EFxxxDS1-AD	
7.5 kW Medium Inertia System		L7PB075U-AD	APM-FFP75DMK-AD	APCS-PFxxJS1-AD**	APCS-ENxxxDS1-AD	
				APCS-PFxxJS1-AD	APCS-EFxxxDS1-AD	
			APM-FFP75DMK2-AD	APCS-PFxxLB1-AD**	APCS-ENxxxDS1-AD	
				APCS-PFxxLB1-AD	APCS-EFxxxDS1-AD	

*Note - Power cables ending in "B-AD" or "B1-AD" are combination power/brake cables, and provide power for both the motor and the brake. A separate brake cable is not required.

** - Non-flex power cable not available for some motors, use the flex cable for both flex and non-flex applications.



L7P Series AC Servo Systems

L7P Servo drive specifications

L7P Servo Drive Specifications												
Model	L7PA004U-AD	L7PA010U-AD	L7PA020U-AD	L7PA035U-AD	L7PA050U-AD	L7PA075U-AD	L7PB010U-AD	L7PB020U-AD	L7PB035U-AD	L7PB050U-AD	L7PB075U-AD	
Price	\$393.00	\$493.00	\$630.00	\$647.00	\$936.00	\$1,339.00	\$545.00	\$652.00	\$672.00	\$938.00	\$1,060.00	
Drawing	PDF	PDF	PDF	PDF	PDF	PDF	PDF	PDF	PDF	PDF	PDF	
Power	Input Power	Three phase 200–230 VAC (-15 to +10%), 50–60Hz**					Three phase 380–480 VAC (-15 to +10%), 50–60Hz					
	Rated Current [Amps]	3.0	6.75	13.5	16.7	32.0	39.4	3.7	8	10.1	17.6	22.8
	Peak Current [Amps]	9.0	20.25	40.5	50.1	90.9	98.5	11.1	24	30.3	47.25	67
	Inrush Current	35A @ 230VAC		55A @ 230VAC		66A @ 230VAC	82A @ 230VAC	68A @ 480VAC			114A @ 480VAC	56A @ 480VAC
Control Performance	Speed Control Range	Maximum 1:5000										
	Frequency Response	Maximum 1KHz or above (when using 19-Bit Serial Encoder)										
	Speed Variation Ratio	± 0.01 % or lower (when load changes between 0 and 100%), ± 0.1 % or lower (temperature 25±10°C)										
	Accel/Decel Time	Straight or S-curve acceleration/deceleration (0–10,000 ms) and 0–1000 ms, unit configurable										
	Input Frequency	1Mpps, line driver / 200kpps, open collector										
	Input Pulse Type	Pulse and direction, CW+CCW, A/B Phase (quadrature)										
Recommended Breaker (UL 489)	15A C trip curve		30A C trip curve		40A B trip curve	50A B trip curve	10A B trip curve	20A B trip curve		30A B trip curve		
Recommended Fuse***	15A	20A	40A	70A	125A	150A	15A	25A	35A	50A	65A	
SCCR Rating***	5kA											
RS-422	Specification	ANSI/TIA/EIA - 422 standard specifications - connects to PLCs with RS485 ports (Click, P-Series, Do-More, etc.)										
	Protocol	MODBUS-RTU										
	Synchro Method	Asynchronous										
	Power Consumption	100mA or below										
	Transmission Speed (bps)	9,600 / 19,200 / 38,400 / 57,600 (can be configured at [0x3002])										
	Distance	200m maximum										
	Terminating Resistance	DIP S/W #2 (On/Off), Built-In 120Ω										
Digital I/O Specifications	Digital Input	Input voltage range: 12–24 VDC Total 16 input channels (configurable) 34 different selectable functions for assignment. (*SV_ON, *POT, *NOT, *A-RST, *START, *STOP, *REGT, *EMG, *HOME, *HSTART, *ISEL0, *ISEL1, *ISEL2, *ISEL3, *ISEL4, *ISEL5, PCON, GAIN2, P_CL, N_CL, MODE, PAUSE, ABSRQ, JSTART, JDIR, PCLR, AOVR, SPD1/LVSF1, SPD2/LVSF2, SPD3, PROBE1, PROBE2)										
	Digital Output	Service rating: 24VDC ± 10%, 120mA 8 output channels are configurable 19 different selectable functions for assignment (*ALARM±, *READY±, *BRAKE±, *INPOS1±, *ORG±, *EOS±, *TGON±, *TLMT±, VLMT±, INSPD±, ZSPD±, WARN±, INPOS2±, IOUT0±, IOUT1±, IOUT2±, IOUT3±, IOUT4±, IOUT5±)										
Analog I/O	Analog Input	2 channel Analog speed input (Command/Override) ± 10V Analog torque command (Command/Override) ± 10V										
	Analog Output	2 channels 15 function outputs can be selectively allocated ± 10V										
Continued on next page												

* Basic allocation signal.

** See Single-phase power input section on the following page for single phase considerations.

*** Use class CC or High Speed J (JHL series) current limiting fuses to prevent nuisance tripping and to increase panel SCCR rating.



L7P Series AC Servo Systems

L7P Servo drive specifications, *continued*

L7P Servo Drive Specifications, <i>continued</i>		
<i>Continued from previous page</i>		
	<i>Model</i>	<i>L7PA004U-AD</i> <i>All Other L7P Series Drives</i>
USB Communication	Connect	Configuration/Monitor: PC Firmware Update: PC or USB On the Go (no PC needed)
	Communication Standard	USB 2.0 full speed (applies standard)
	Specification	PC, USB 2.0 full speed (applies standard)
Internal Function	Mechanical Brake	Standard built-in brake (activated when the servo alarm goes off or when the servo is OFF)
	Regenerative Braking	Default built-in, external installation possible
	Display Function	7-segment display (5 digits)
	Self-setting Function	Drive node address can be set using rotary switch and DIP switch #3 (available Nodes = 0–31)
	Additional Function	Gain tuning, alarm history, JOG operation, homing
	Protection Function	Excessive current/current limit/voltage/speed, overload, overheating, low voltage, encoder failure, position following failure, current sensing failure
Operation Environment	Operating Temperature	0–50 °C [32–122 °F]
	Storage Temperature	-20 to -70°C [-4 to 158 °F]
	Operating Humidity	Below 80% relative humidity
	Storage Humidity	Below 90% relative humidity (avoid dew-condensation)
	Environment	Indoor, avoid corrosive, inflammable gas, or liquid and electrically conductive dust
	Approvals	cUR _{US} (E479434), CE cUL _{US} (E479434), CE

Single-phase Power Input

Although designed with 3-phase AC input power in mind, some L7P systems are capable of supporting single-phase AC input power. With three phase AC supply, the L7P motor/drive combination supplies 300% rated maximum motor torque (see the Instantaneous Operation Range in the torque-speed charts above). With single phase AC supply some ratings will have limited maximum/intermittent torque, and/or the next larger drive size will be required.

Drive Derating for 230V Single-phase Usage		
3-phase Motor/Drive Rating	Drive to use with Single-phase Input	Motor Torque Derating for Single-phase Input
100W/200W/400W	L7PA004U-AD	Single phase and three phase input both produce 300% max torque. No derating required.
750W	L7PA010U-AD	Single phase and three phase input both produce 300% max torque. No derating required.
1kW	L7PA010U-AD or L7PA020U-AD	2kW drive produces 300% max torque. The 1kW drive can be used, but the motor can only provide 200% max torque.
1.5 kW/1.6 kW	L7PA035U-AD	3.5 kW drive produces 200% max torque
2.2 kW		3.5 kW drive produces 150% max torque
3.5 kW and up	n/a	No single phase capability

L7P Drive Standard Installation

L7P Drive Installation Spacing

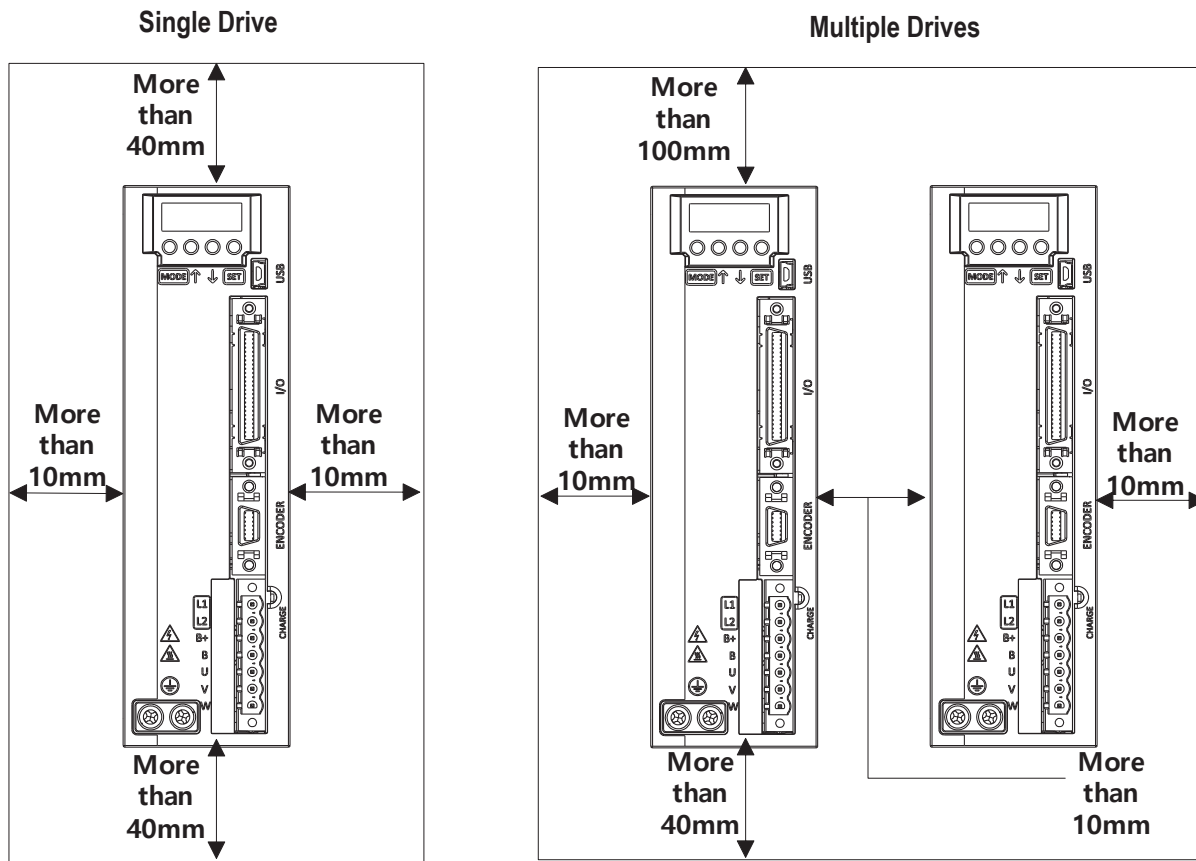

L7P Drive Installation Concerns:

- Install external regenerative resistors so that any heat generated does not affect the drive.
- Vertical installation only. For proper heat dissipation, ensure the back of the drive makes good contact with the subpanel.
- Protect the drive from metal chips and other falling debris during control panel assembly.
- Make sure that oil, water, or metal dust do not enter the drive.
- Protect the control panel by using an air purge system when installing it in any area where there are harmful gases or dust.

L7P Drive Wiring

L7P Power Supply Wiring



NOTE: Single phase can use 2 of R, S, or T. See "Single-phase Power Input" on page tSRV-64 for more information.

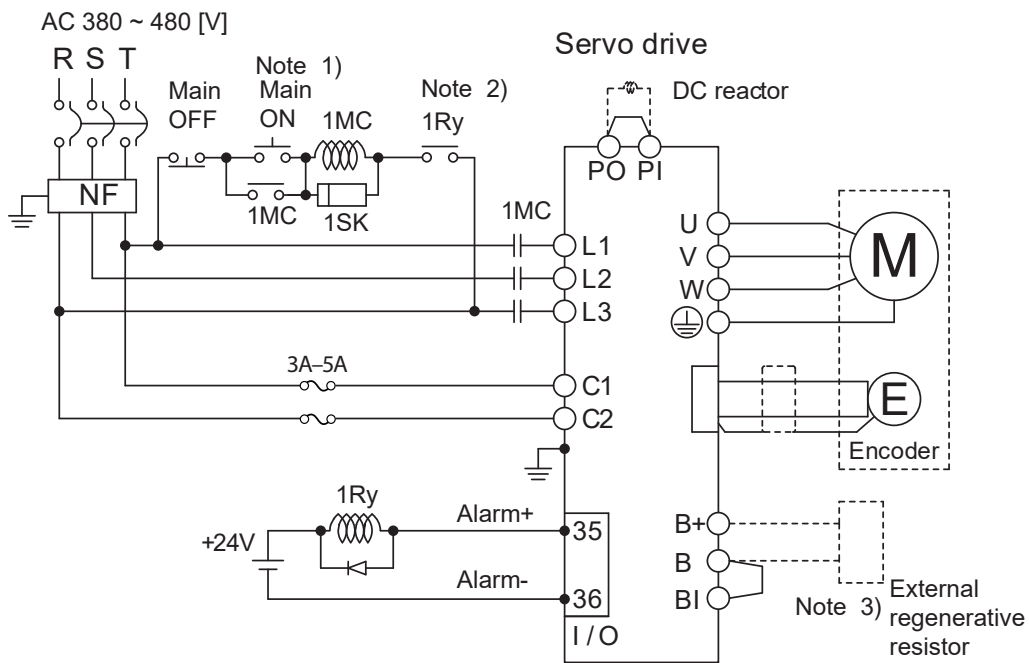
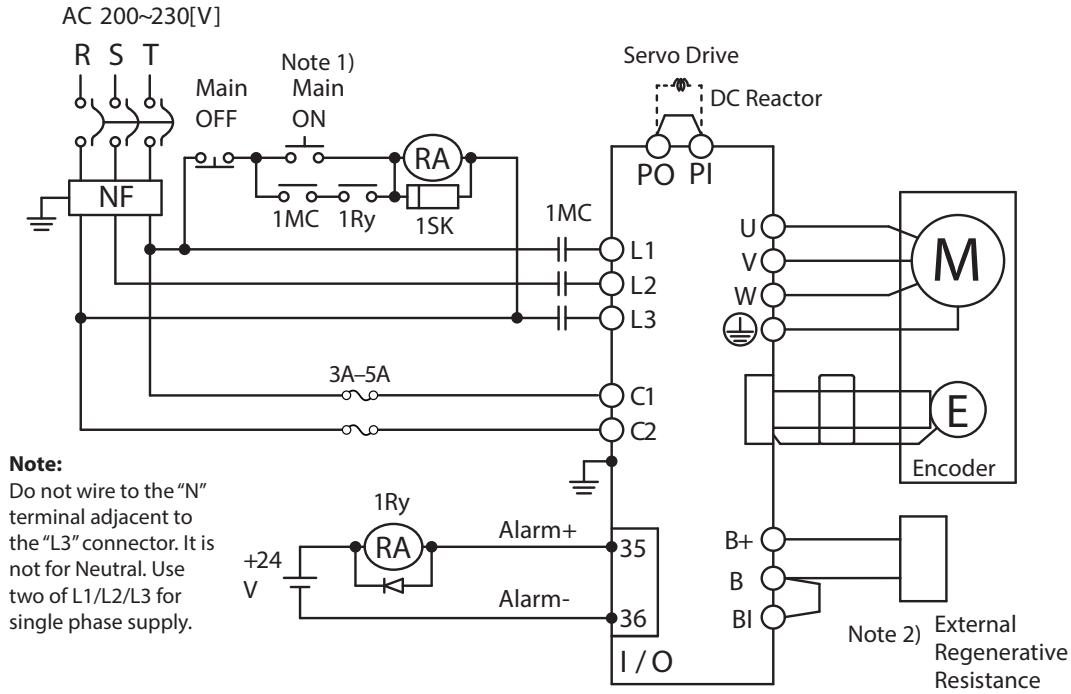

NOTE 1: About 1–2 seconds are required from main power supply to alarm signal output. Hold the main power on for 2 seconds until the alarm circuit ("1Ry") will latch main power ON.



NOTES 2 & 3: Remove the jumper for the internal resistor between B and BI, and connect the external resistor to the B+ and B pins. If an external regen resistor is required, see the available regen resistors under the Motion Control category at AutomationDirect.com (APCS-140R50-AD, APCS-300R30-AD, etc.).

L7P Drive Wiring, continued

Connect the L7P RS422 port to a PLC with an RS485 port:

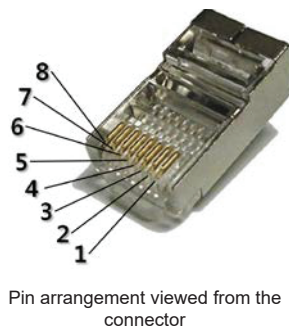
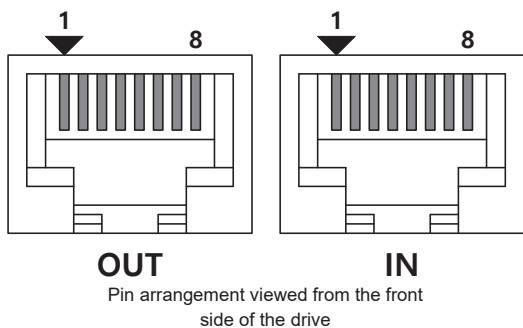
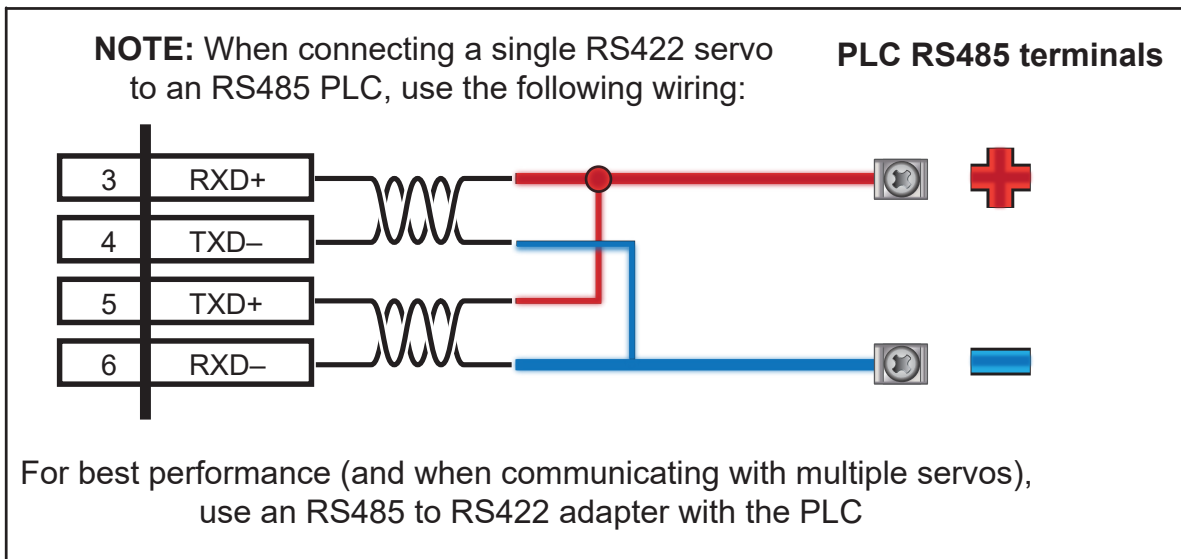

Pin #	Pin Function
1	Not used
2	Not used
3	RXD+
4	TXD-
5	TXD+
6	RXD-
7	Not used
8	Not used



NOTE: When connecting multiple drives, use a standard RJ45 ethernet patch cable (not a crossover cable) for the serial network. On the last drive only, set DIP switch #2 = ON (120 Ohm terminating resistor).



L7P/iX7NH AC Servo Systems

60–80 mm Frame Motor Specifications

L7P/iX7NH 60–80 mm Frame Motor Specifications										
Model	APMC-FBL01AMK-AD	APMC-FBL02AMK-AD	APMC-FBL04AMK-AD	APMC-FCL08AMK-AD	APMC-FCL10AMK-AD	APMC-FBL01AMK2-AD	APMC-FBL02AMK2-AD	APMC-FBL04AMK2-AD	APMC-FCL08AMK2-AD	APMC-FCL10AMK2-AD
Price	\$273.00	\$318.00	\$329.00	\$404.00	\$449.00	\$490.00	\$515.00	\$525.00	\$604.00	\$640.00
Drawing	PDF	PDF	PDF	PDF	PDF	PDF	PDF	PDF	PDF	PDF
Input Voltage	230VAC									
Drive Compatibility	L7P and iX7NH drives									
Integrated Brake	No					Yes				
Flange Size (mm)	60			80		60			80	
Rated Power [kW]	0.1	0.2	0.4	0.75	1	0.1	0.2	0.4	0.75	1
Rated Torque [N·m] ^{Note 1}	0.32	0.64	1.27	2.39	3.18	0.32	0.64	1.27	2.39	3.18
Max. Torque [N·m]	0.96	1.91	3.82	7.16	9.55	0.96	1.91	3.82	7.16	9.55
Rated Speed [rpm]	3000									
Max. Speed [rpm]	5000									
Mechanical Time Constant [ms]	0.926	0.518	0.374	0.609	0.492	0.926	0.518	0.374	0.609	0.492
Rated current [Amps] rms	0.95	1.45	2.6	5.02	5.83	0.95	1.45	2.6	5.02	5.83
Max. Instantaneous Current [Amps] rms	2.85	4.35	7.8	15.07	17.5	2.85	4.35	7.8	15.07	17.5
Rated Power Rate [kW/s]	11.09	27.6	27.07	45.09	62.08	11.09	27.6	27.07	45.09	62.08
Electrical Time Constant [ms]	2.416	3.488	4.271	5.774	6.919	2.416	3.488	4.271	5.774	6.919
Insulation Class	Class BE (CE, UL)									
Insulation Resistance	>10MΩ, 500VDC									
Insulation Strength	1.8 kVAC, 1 second									
Rotor Inertia [x10 ⁻⁴ kg m ²]	0.091	0.147	0.248	1.264	1.632	0.091	0.147	0.248	1.264	1.632
Allowable Load Inertia Ratio	20 times motor inertia			15 times motor inertia		20 times motor inertia			15 times motor inertia	
Max Radial Loading [N]	206			255		206			255	
Max Axial Loading [N]	69			98		69			98	
Vibration Grade [μm]	V15									
Vibration Capacity	19.6 m/s ² or lower (2.5G)									
Speed/Position Detector	Serial multi-turn built-in type (19-bit)									
Weight [kg]	0.56	0.74	1.06	2.68	3.3	1.28	1.46	1.78	3.45	4.07

Note 1—The rated torque is the continuous permissible torque between the 0°C and 40°C operating temperature which is suitable for a servo motor mounted with the following heat sink dimensions: 250mm x 250mm x 6mm made from aluminum (or mounted to equipment with an equivalent heat sinking capability).



L7P/iX7NH AC Servo Systems

130mm Frame Motor Specifications

L7P/iX7NH 130mm Frame Motor Specifications														
Model	APM-FE15AMK-AD	APM-FE16DMK-AD	APM-FE22DMK-AD	APM-FE15AMK2-AD	APM-FE16DMK2-AD	APM-FE22DMK2-AD	APM-FEP09AMK-AD	APM-FEP15AMK-AD	APM-FEP16DMK-AD	APM-FEP22DMK-AD	APM-FEP09AMK2-AD	APM-FEP15AMK2-AD	APM-FEP16DMK2-AD	APM-FEP22DMK2-AD
Price	\$644.00	\$690.00	\$635.00	\$845.00	\$893.00	\$814.00	\$590.00	\$646.00	\$698.00	\$642.00	\$793.00	\$878.00	\$930.00	\$820.00
Drawing	PDF	PDF	PDF	PDF	PDF	PDF	PDF	PDF	PDF	PDF	PDF	PDF	PDF	PDF
Input Voltage	230VAC						460VAC							
Drive Compatibility	L7P and iX7NH drives						L7P drives							
Integrated Brake	No			Yes			No				Yes			
Flange Size (mm)	130													
Rated Power [kW]	1.5	1.6	2.2	1.5	1.6	2.2	0.9	1.5	1.6	2.2	0.9	1.5	1.6	2.2
Rated Torque [N·m] Note 1	4.77	7.63	10.5	4.77	7.63	10.5	2.86	4.77	7.64	10.5	2.86	4.77	7.64	10.5
Max. Torque [N·m]	14.32	22.92	31.51	14.32	22.92	31.51	8.59	14.32	22.92	31.51	8.59	14.32	22.92	31.51
Rated Speed [rpm]	3000	2000		3000	2000		3000		2000		3000		2000	
Max. Speed [rpm]	5000	3000		5000	3000		5000		3000		5000		3000	
Mechanical Time Constant [ms]	1.520	1.278	1.176	1.520	1.278	1.176	2.428	1.609	1.337	1.261	2.428	1.609	1.337	1.261
Rated current [Amps] rms	9.15	10.98	12.97	9.15	10.98	12.97	3.47	6.68	4.97	6.8	3.47	6.68	4.97	6.8
Max. Instantaneous Current [Amps] rms	27.45	32.94	38.91	27.45	32.94	38.91	10.4	20.03	14.92	20.4	10.4	20.03	14.92	20.4
Rated Power Rate [kW/s]	22.38	39.89	57.9	22.38	39.89	57.9	14.5	22.4	39.92	57.95	14.5	22.4	39.92	57.95
Electrical Time Constant [ms]	9.819	10.352	11.284	9.819	10.352	11.284	7.763	9.761	10.656	10.623	7.763	9.761	10.656	10.623
Insulation Class	B													
Insulation Resistance	10MΩ													
Insulation Strength	1.8 kVAC, 1 second						2.2 kVAC, 1 second							
Rotor Inertia [x10 ⁻⁴ kg m ²]	10.18	14.62	19.43	10.18	14.62	19.43	5.659	10.179	14.619	19.04	5.659	10.179	14.619	19.04
Allowable Load Inertia Ratio	10 times motor inertia													
Max Radial Loading [N]	725													
Max Axial Loading [N]	362													
Vibration Grade [μm]	15													
Vibration Capacity	5G													
Speed/Position Detector	Serial type (19-bit)													
Weight [kg]	6.7	8.5	10.1	8.28	10.02	11.59	5.04	6.7	8.5	10.1	6.58	8.28	10.02	11.59

Note 1—The rated torque is the continuous permissible torque between the 0°C and 40°C operating temperature which is suitable for a servo motor mounted with the following heat sink dimensions: 250mm x 250mm x 6mm made from aluminum (or mounted to equipment with an equivalent heat sinking capability).



L7P/iX7NH AC Servo Systems

180mm Frame Motor Specifications

L7P/iX7NH 180mm Frame Motor Specifications												
Model	APM-FF35DMK-AD	APM-FF55DMK-AD	APM-FF75DMK-AD	APM-FF35DMK2-AD	APM-FF55DMK2-AD	APM-FF75DMK2-AD	APM-FFP35DMK-AD	APM-FFP55DMK-AD	APM-FFP75DMK-AD	APM-FFP35DMK2-AD	APM-FFP55DMK2-AD	APM-FFP75DMK2-AD
Price	\$834.00	\$922.00	\$1,092.00	\$1,081.00	\$1,162.00	\$1,324.00	\$834.00	\$918.00	\$1,095.00	\$1,094.00	\$1,158.00	\$1,327.00
Drawing	PDF	PDF	PDF	PDF	PDF	PDF	PDF	PDF	PDF	PDF	PDF	PDF
Input Voltage	230VAC						460VAC					
Drive Compatibility	L7P and iX7NH drives						L7P drives					
Integrated Brake	No			Yes			No			Yes		
Flange Size (mm)	180											
Rated Power [kW]	3.5	5.5	7.5	3.5	5.5	7.5	3.5	5.5	7.5	3.5	5.5	7.5
Rated Torque [N·m] ^{Note 1}	16.7	26.25	35.81	16.7	26.25	35.81	16.71	26.26	35.81	16.71	26.26	35.81
Max. Torque [N·m]	50.1	78.76	89.53	50.1	78.76	89.53	50.13	65.65	89.52	50.13	65.65	89.52
Rated Speed [rpm]	2000											
Max. Speed [rpm]	3000											
Mechanical Time Constant [ms]	1.222	0.829	0.723	1.222	0.829	0.723	1.058	0.847	0.764	1.058	0.847	0.764
Rated current [Amps] rms	16.48	28.78	32.95	16.48	28.78	32.95	9.09	14.70	18.97	9.09	14.70	18.97
Max. Instantaneous Current [Amps] rms	49.44	86.34	82.38	49.44	86.34	82.38	27.26	36.75	47.42	27.26	36.75	47.42
Rated Power Rate [kW/s]	59.89	93.27	120.15	59.89	93.27	120.15	59.98	93.38	120.15	59.98	93.38	120.15
Electrical Time Constant [ms]	15.021	19.086	20.567	15.021	19.086	20.567	14.452	23.484	20.351	14.452	23.484	20.351
Insulation Class	B											
Insulation Resistance	10MΩ											
Insulation Strength	1.8 kVAC, 1 second						2.2 kVAC, 1 second					
Rotor Inertia [x10 ⁻⁴ kg m ²]	46.56	73.85	106.7	46.56	73.85	106.7	46.56	73.85	106.73	46.56	73.85	106.73
Allowable Load Inertia Ratio	5 times motor inertia											
Max Radial Loading [N]	1548											
Max Axial Loading [N]	519											
Vibration Grade [μm]	15											
Vibration Capacity	5G											
Speed/Position Detector	Serial type (19-bit)											
Weight [kg]	17.4	25.2	34	24.6	32.4	39	17.4	25.2	34	24.6	32.4	39

Note 1—The rated torque is the continuous permissible torque between the 0°C and 40°C operating temperature which is suitable for a servo motor mounted with the following heat sink dimensions: 250mm x 250mm x 6mm made from aluminum (or mounted to equipment with an equivalent heat sinking capability).



L7P/iX7NH AC Servo Systems

Environmental Specifications

L7P/iX7NH Motor Environmental Specifications			
Model Series	APMC-FBL/FCL Motors	FE/FEP Motors	FF/FFP Motors
IP Rating	Fully closed self-cooling IP67 ¹	Fully closed self-cooling IP65 ¹	
Rated Time	Continuous		
Operating Temperature	0 to 40 °C [32 to 104 °F]		
Storage Temperature	-10 to 60 °C [14 to 140 °F]		
Operating Humidity	Below 80% RH		
Storage Humidity	Below 90% RH (non condensing)		
Atmosphere	Avoid direct sunlight and corrosive/flammable gas or liquid		
E/V	Elevation/vibration 49m/s ² (5G)		
Agency Approvals	cUR _{US} (E255738), CE		

Note 1 - Shaft connection not included. The IP rating for attached reducers/gearboxes is not guaranteed. Cables may not qualify marked IP rating if bent beyond designated specifications. Use suggested cables for maintaining IP rating.



LS Electric AC Servo Systems

Drive Software

Drive CM Configuration Software

Drive CM is an optional free downloadable configuration software package for LS Electric servo drives. A PC may be directly connected to the servo drive via any standard USB-A to USB mini-B cable (SV2-PGM-USB15 or SV2-PGM-USB30 recommended).

Features

- Easy-to-use setup wizard guides you through the most common setup functions.
- Digital I/O / Jog Control allows the user to operate the servo system from the PC. This allows the servo to perform some basic motion and check the I/O during startup.
- Parameter Object editor for setting up all drive parameters.
- Tune and check the servo response in real-time using the scope feature.
- Upload and download the drive configuration. Save the drive configuration as a file for backup or future use.
- Edit the drive configuration.
- View all drive faults.
- View drive variable trends in real-time.
- (L7P/L7C series only) Set up 64 internal Indexes (point-to-point moves) that can be triggered by digital inputs or serial communications. Indexes can repeat and can initiate another Index when one move completes.

Download

Download the Drive CM software from AutomationDirect's LS Electric support page:

<https://support.automationdirect.com/products/lselectric.html>

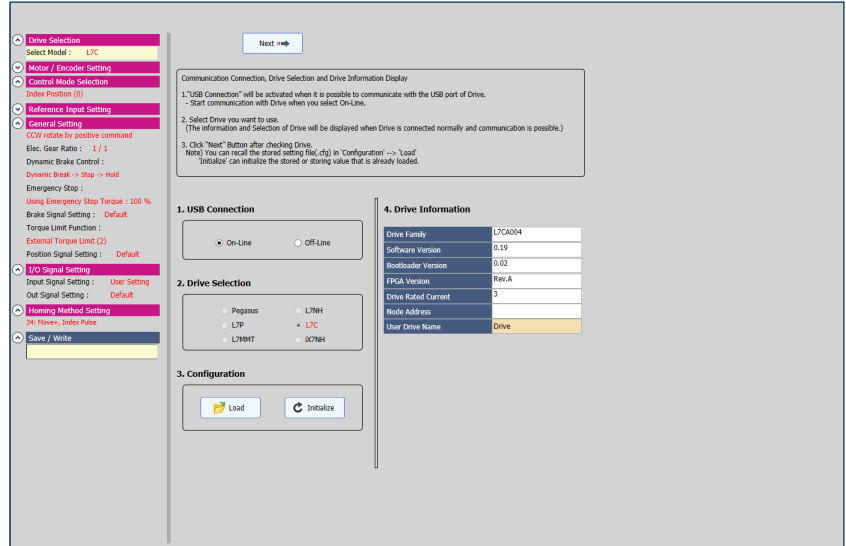

Setup Wizard Screen

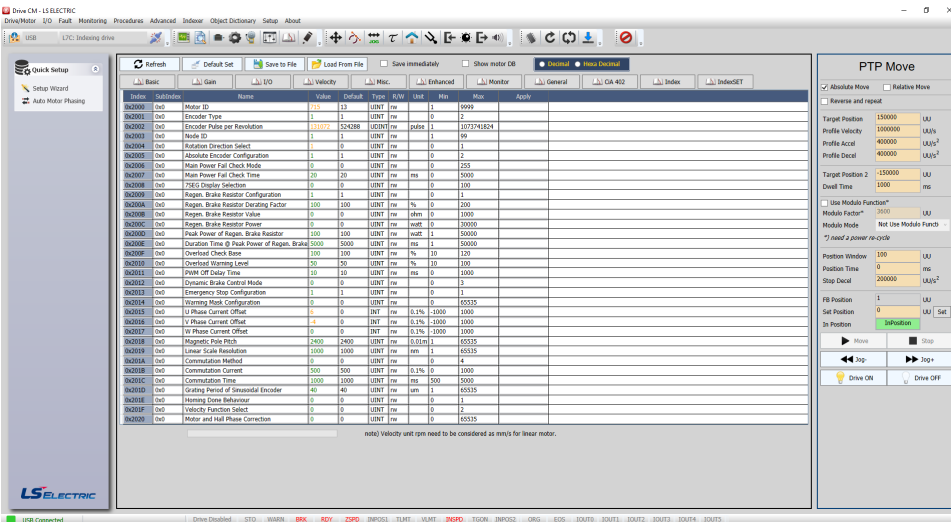

Drive CM Software Interface

Parameter Object Editor

The Drive CM configuration tool logically organizes all servo drive object parameters for viewing and editing using the Object Dictionary screen. Each parameter has a factory default that usually allows the servo to run "out-of-the-box".

The parameters can be easily changed with available setting ranges displayed. Tuning modes and parameters can also be changed using Drive CM. After the parameters have been defined, the complete setup can be stored and archived. Drive configurations can be uploaded, edited, saved, and downloaded as often as necessary.

Using the Drive CM software you can also configure and commission your drive without having to be connected to the master controller.



LS Electric AC Servo Systems

Drive Software, continued

Digital I/O, Jog Control, and Scope

The Digital I/O / Jog Control screen allows the user to operate the servo system from the PC. This is a great aid during start-up to allow the servo to perform some basic motion and to check the I/O.

Drive CM also includes a powerful scope function that allows the user to have as many as four channels of data displayed simultaneously. Each channel has a drop-down table to select the data to be displayed. The scope has the ability to save traces to a file and load those traces for offline review/analysis. This function is a valuable tool for tuning LS Electric servo drives.

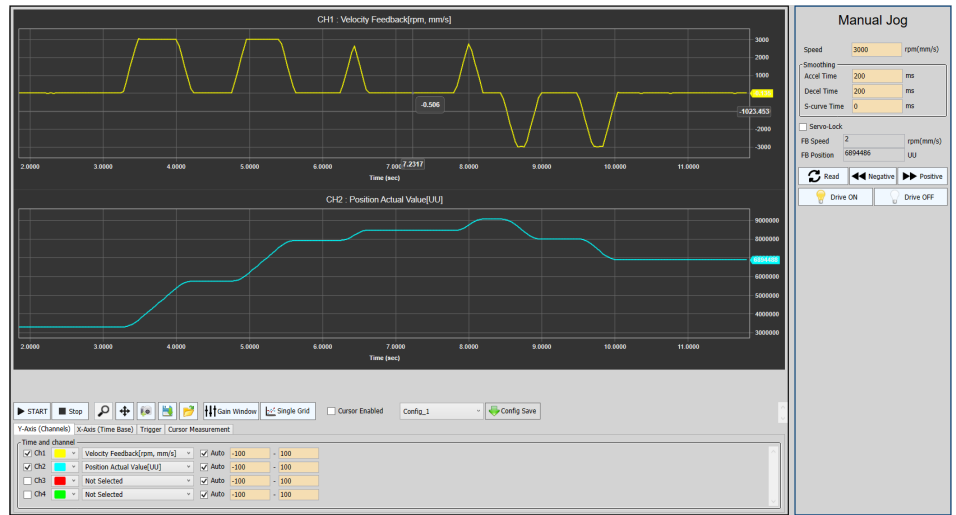

Jog Control / Scope Screen

The General Setup Screen is divided into several sections: Motor Direction, Motor Parameters (including EGEA1-4), Brake, Torque Limit Selection, and Drive Configuration. It allows for detailed parameter adjustment for the servo drive.

General Setup Screen

No.	Message	Comment
1	[3]Encoder cable open	Newest alarm
2	[3]Encoder cable open	
3	[3]Encoder cable open	
4	[3]Encoder cable open	
5	[3]Encoder cable open	
6	[00]No error	
7	[00]No error	
8	[00]No error	
9	[00]No error	
10	[00]No error	
11	[00]No error	
12	[00]No error	
13	[00]No error	
14	[00]No error	
15	[00]No error	
16	[00]No error	Oldest alarm

Alarm History Screen

The Indexer Setting Screen is used for configuring absolute and relative indexing for 8 different indices (Index 0 to Index 7). It includes fields for Index Type, Distance, Velocity, Acceleration, Registration Distance, and Registration Velocity, along with dwell times and repeat counts.

Indexer Setting Screen (L7P/L7C series only)

Index	SubIndex	Name	Value	Default	Type	R/W	Unit	Min	Max	Apply
0x2000	0x0	Motor ID*	715	13	UINT	rw		1	9999	
0x2001	0x0	Encoder Type*	4	2	UINT	rw		0	99	
0x2002	0x0	Encoder Pulse per Revolution*	524288	524288	LJUNIT	rw	pulse	0	1073741824	
0x2003	0x0	Node ID*	59	0	UINT	rw		0	65535	
0x2004	0x0	Rotation Direction Select*	0	0	UINT	rw		0	1	
0x2005	0x0	Absolute Encoder Configuration*	1	1	UINT	rw		0	2	
0x2006	0x0	Main Power Fail Check Mode	0	0	UINT	rw		0	255	
0x2007	0x0	Main Power Fail Check Time	40	40	UINT	rw	ms	0	5000	
0x2008	0x0	T/SG Overlay Selection	0	0	UINT	rw		0	100	
0x2009	0x0	Regen. Brake Resistor Configuration	0	0	UINT	rw		0	1	
0x200A	0x0	Regen. Brake Resistor Derating Factor	100	100	UINT	rw	%	0	200	
0x200B	0x0	Regen. Brake Resistor Value	100	0	UINT	rw	ohm	0	1000	
0x200C	0x0	Regen. Brake Resistor Power	50	0	UINT	rw	watt	0	30000	
0x200D	0x0	Peak Power of Regen. Brake Resistor	100	100	UINT	rw	watt	1	50000	
0x200E	0x0	Duration Time @ Peak Power of Regen. Brake	5000	5000	UINT	rw	ms	1	50000	
0x200F	0x0	Overload Check Selection	100	100	UINT	rw	%	0	120	
0x2010	0x0	Overload Warning Level	50	50	UINT	rw	%	10	100	
0x2011	0x0	PWM OFF Delay Time	10	10	UINT	rw	ms	0	1000	
0x2012	0x0	Dynamic Brake Control Mode	0	0	UINT	rw		0	3	
0x2013	0x0	Emergency Stop Configuration	1	1	UINT	rw		0	1	
0x2014	0x0	Warning Mask Configuration	0	0	UINT	rw		0	65535	
0x2015	0x0	U Phase Current Offset	0	0	INT	rw	0.1%	-1000	1000	
0x2016	0x0	V Phase Current Offset	0	0	INT	rw	0.1%	-1000	1000	
0x2017	0x0	W Phase Current Offset	0	0	INT	rw	0.1%	-1000	1000	
0x2018	0x0	Magnetic Pole Pitch*	2400	2400	UINT	rw	0.01m	1	65535	
0x2019	0x0	Linear Scale Resolution*	1000	1000	UINT	rw	mm	1	65535	
0x201A	0x0	Commutation Method*	0	0	UINT	rw		0	4	
0x201B	0x0	Commutation Current	500	500	UINT	rw	0.1%	0	1000	

Object Dictionary Screen

Drive Software, *continued*

Modbus TCP Webserver (iX7NH Series)

When using Modbus TCP as the control mode, the drive can generate a built-in webserver to accomplish most of the tasks Drive CM is used for (configuration, jog, fault monitoring/reset, firmware upgrade, etc.). Setting the drive DIP switches to Node 99 enables Modbus TCP and enables the non-secure webserver (does not use https). If your IT security policy does not allow web servers on your network, the webserver can be completely disabled by setting the Node ID rotary DIP switches to Node 98 (enables Modbus TCP with no webserver). The Node 98 functionality is available in firmware versions 1.15 and above.

The screenshot displays the webserver interface for an LS Electric AC Servo Drive. It is divided into several functional sections:

- Servo Drive:** Shows configuration parameters for the drive unit, including Device Name (iX7NHA004), Rated Current (3 Arms), F/W Version (313.0), and Boot Version (0.03).
- Servo Motor/Encoder:** Displays motor specifications such as Motor ID (715), Rated Torque (0.681 Nm), Rated Speed (3000 rpm), Maximum Speed (5000 rpm), Encoder Type (4), and Encoder Resolution (524288 ppr).
- Manual Jog:** Provides controls for speed (500 rpm/mm/s), smoothing parameters (Accel Time: 200 ms, Decel Time: 200 ms, S-curve Time: 0 ms), and Servo-Lock settings (FB Speed: 0 rpm/mm/s, FB Position: 0 UU). It includes buttons for CCW, CW, STOP, SVON, and SVOFF.
- Life Diagnosis:** Monitors system health with metrics like Accumulated Usage Time (9days 23h:45m:9s), Charge Relay Operation Count (147), DB Relay Operation Count (147), Capacitor Life Time (0.34%), and Fan Life Time (0%).
- Navigation:** A sidebar on the left lists menu items such as Servo Information, Motor/Encoder, Fault, Monitoring, Procedure, Object Dictionary, and Setup.
- Status:** A bottom status bar shows Drive Enable, STO, ALM, BRK, RDY, ZSPD, INPOS1, TLMT, VLMT, INSPD, TGON, INPOS2, and WARN.

Example Webserver Screen

L7C/L7P Series AC Servo Systems

Accessories

CN1 Accessories

For L7x series drives, two methods are available for creating I/O connections.

Option 1:

Terminal blocks + cables:

- [APC-VSCN1T-AD](#)
- [APC-VSCN1T01-AD](#)
- [APC-VSCN1T02-AD](#)

APC-VSCN1T terminals ship with a universal labeling strip (A1-A25, B1-B25). A labeling template with designations specifically for the L7x drive can be downloaded from any of the drive pages or the terminal block page (www.automationdirect.com/pn/apc-vscn1t-ad).



APC-VSCN1T-AD

Option 2:

Flying lead cables:

- [APC-CN101A-AD](#)
- [APC-CN102A-AD](#)
- [APC-CN103A-AD](#)



APC-CN101A-AD



NOTE: For L7C drives, do not use APC-VSCN1T(xx)-AD feedthrough terminal block if using PLC/Drive serial communication. Communication errors may occur due to disconnects in cable shields. Use APC-CN10xA-AD flying lead cables.

Part Number	Price	Description	Cable Length	Drawing	Compatible Drives
APC-VSCN1T-AD	\$75.00	LS Electric CN1 feedthrough terminal block, 50-pole, DIN rail mount	0.5 m [1.6 ft]	PDF	All L7C and L7P drives
APC-VSCN1T01-AD	\$84.00		1.0 m [3.2 ft]	PDF	
APC-VSCN1T02-AD	\$92.00		2.0 m [6.5 ft]	PDF	
APC-CN101A-AD	\$46.00	LS Electric control cable, 50-pin connector to pigtail.	1.0 m [3.2 ft]	PDF	
APC-CN102A-AD	\$50.00		2.0 m [6.5 ft]	PDF	
APC-CN103A-AD	\$55.00		3.0 m [9.8 ft]	PDF	

LS ELECTRIC L7C Series AC Servo Systems

Accessories

L7C Terminal Assignment Table

CAUTION: This terminal assignment table is for use with L7C drives ONLY. Using this table with non-L7C series drives could damage your equipment as terminal assignments are different for each drive series.

APC-VSCN1T-AD

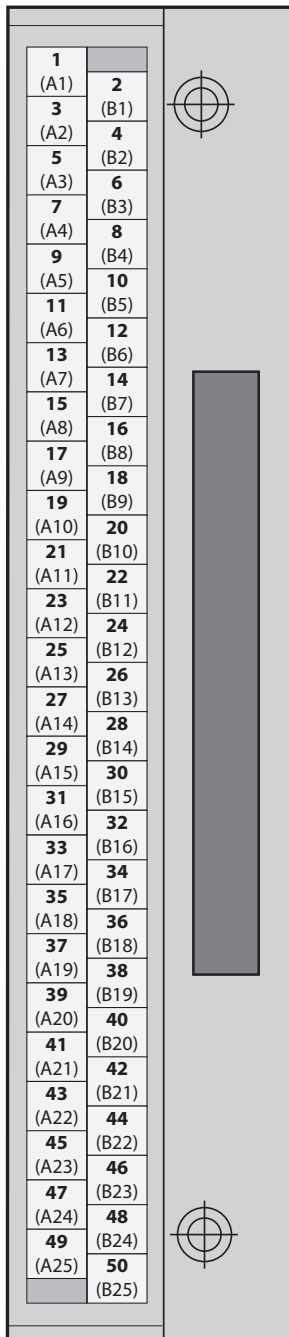

You can download a printable terminal label at <https://www.automationdirect.com/pn/APC-VSCN1T-AD>

L7C Drive Terminal Assignments					
Terminal	Drive I/O Pin/Wire #	Description	Wire Color	Stripe Color	Number of Stripes
A1	1	AI-1 (TRQCOM)	Orange	Black	1
B1	2	TXD+	Orange	Red	1
A2	3	TXD-	Orange	Black	2
B2	4	Z0	Orange	Red	2
A3	5	/Z0	Orange	Black	3
B3	6	RXD+	Orange	Red	3
A4	7	RXD-	Orange	Black	4
B4	8	A-GND	Orange	Red	4
A5	9	PF+	Orange	Black	5
B5	10	PF-	Orange	Red	5
A6	11	PR+	Yellow	Black	1
B6	12	PR-	Yellow	Red	1
A7	13	N/C	Yellow	Black	2
B7	14	DO-8	Yellow	Red	2
A8	15	DO-7	Yellow	Black	3
B8	16	DO-6	Yellow	Red	3
A9	17	DI-5	Yellow	Black	4
B9	18	DI-9	Yellow	Red	4
A10	19	DI-8	Yellow	Black	5
B10	20	DI-7	Yellow	Red	5
A11	21	DI-4	Gray	Black	1
B11	22	DI-3	Gray	Red	1
A12	23	DI-2	Gray	Black	2
B12	24	DO-GND24	Gray	Red	2
A13	25	DO-GND24	Gray	Black	3
B13	26	N/C	Gray	Red	3
A14	27	AI-2 (SPDCOM)	Gray	Black	4
B14	28	N/C	Gray	Red	4
A15	29	N/C	Gray	Black	5
B15	30	B0	Gray	Red	5
A16	31	/B0	White	Black	1
B16	32	AO	White	Red	1
A17	33	/AO	White	Black	2
B17	34	+12V	White	Red	2
A18	35	-12V	White	Black	3
B18	36	ENC SG	White	Red	3
A19	37	N/C	White	Black	4
B19	38	DO-1+	White	Red	4
A20	39	DO-1-	White	Black	5
B20	40	DO-2+	White	Red	5
A21	41	DO-2-	Pink	Black	1
B21	42	N/C	Pink	Red	1
A22	43	DO-3	Pink	Black	2
B22	44	DO-4	Pink	Red	2
A23	45	DO-5	Pink	Black	3
B23	46	DI-6	Pink	Red	3
A24	47	DI-1	Pink	Black	4
B24	48	DI-A	Pink	Red	4
A25	49	PULCOM	Pink	Black	5
B25	50	+24v	Pink	Red	5

LS ELECTRIC L7P Series AC Servo Systems

Accessories

L7P Terminal Assignment Table

CAUTION: This terminal assignment table is for use with L7P drives ONLY. Using this table with non-L7P series drives could damage your equipment as terminal assignments are different for each drive series.



APC-VSCN1T-AD

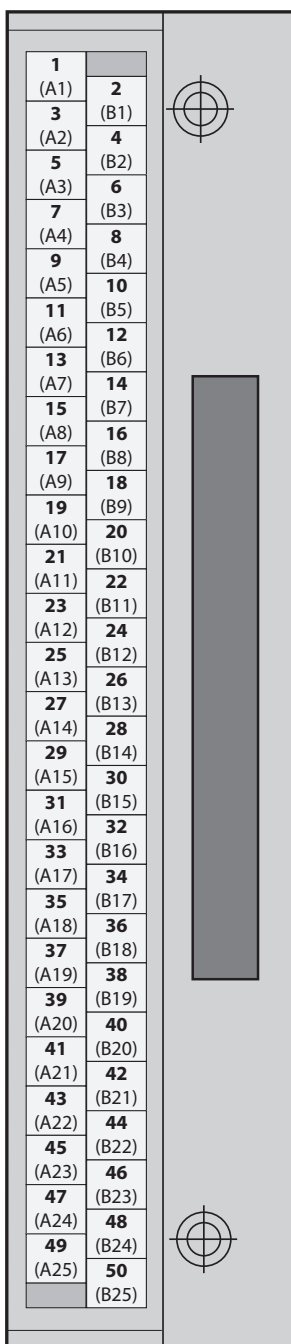

You can download a printable terminal label at <https://www.automationdirect.com/pn/APC-VSCN1T-AD>

L7P Drive Terminal Assignments					
Terminal	Drive I/O Pin/ Wire #	Description	Wire Color	Stripe Color	Number of Stripes
A1	1	AO	Orange	Black	1
B1	2	/AO	Orange	Red	1
A2	3	BO	Orange	Black	2
B2	4	/BO	Orange	Red	2
A3	5	ZO	Orange	Black	3
B3	6	/ZO	Orange	Red	3
A4	7	A-TLMT	Orange	Black	4
B4	8	AGND	Orange	Red	4
A5	9	A-OVR	Orange	Black	5
B5	10	AGND	Orange	Red	5
A6	11	+24V	Yellow	Black	1
B6	12	DI-1	Yellow	Red	1
A7	13	DI-2	Yellow	Black	2
B7	14	DI-3	Yellow	Red	2
A8	15	DI-4	Yellow	Black	3
B8	16	DI-5	Yellow	Red	3
A9	17	DI-6	Yellow	Black	4
B9	18	DI-7	Yellow	Red	4
A10	19	DI-8	Yellow	Black	5
B10	20	N/C	Yellow	Red	5
A11	21	+24v	Gray	Black	1
B11	22	DI-9	Gray	Red	1
A12	23	DI-10	Gray	Black	2
B12	24	DI-11	Gray	Red	2
A13	25	DI-12	Gray	Black	3
B13	26	DI-13	Gray	Red	3
A14	27	DI-14	Gray	Black	4
B14	28	DI-15	Gray	Red	4
A15	29	DI-16	Gray	Black	5
B15	30	PULCOM 24V pwr input	Gray	Red	5
A16	31	PF+	White	Black	1
B16	32	PF-	White	Red	1
A17	33	PR+	White	Black	2
B17	34	PR-	White	Red	2
A18	35	DO-1+	White	Black	3
B18	36	DO-1-	White	Red	3
A19	37	DO-2+	White	Black	4
B19	38	DO-2-	White	Red	4
A20	39	DO-3+	White	Black	5
B20	40	DO-3-	White	Red	5
A21	41	DO-4+	Pink	Black	1
B21	42	DO-4-	Pink	Red	1
A22	43	DO-5+	Pink	Black	2
B22	44	DO-5-	Pink	Red	2
A23	45	DO-6+	Pink	Black	3
B23	46	DO-6-	Pink	Red	3
A24	47	DO-7+	Pink	Black	4
B24	48	DO-7-	Pink	Red	4
A25	49	DO-8+	Pink	Black	5
B25	50	DO-8-	Pink	Red	5

Accessories

CN1 Accessories

For iX7NH series drives, two methods are available for creating I/O connections.

Option 1:

Terminal blocks + cables:

- [APCS-L7NCN1T-AD](#)
- [APCS-L7NCN1T01-AD](#)
- [APCS-L7NCN1T015-AD](#)
- [APCS-L7NCN1T02-AD](#)

APCS-L7NCN1T terminals ship with a universal labeling strip (A1-A10, B1-B10). A labeling template with designations specifically for the iX drive can be downloaded from any of the drive pages or the terminal block page (www.automationdirect.com/pn/apcs-l7ncn1t-ad).

Option 2:

Flying lead cables:

- [APCS-CN101A-AD](#)
- [APCS-CN102A-AD](#)
- [APCS-CN103A-AD](#)



APCS-L7NCN1T-AD

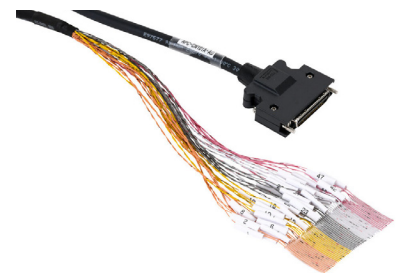

APCS-CN101A-AD

Part Number	Price	Description	Cable Length	Drawing	Compatible Drives
APCS-L7NCN1T-AD	\$56.00	LS Electric CN1 feedthrough terminal block, 20-pole, DIN rail mount. For use with all LS Electric iX7 series drives.	0.5 m [1.6 ft]	PDF	All iX7NH drives
APCS-L7NCN1T01-AD	\$59.00		1.0 m [3.2 ft]	PDF	
APCS-L7NCN1T015-AD	\$61.00		1.5 m [4.9 ft]	PDF	
APCS-L7NCN1T02-AD	\$63.00		2.0 m [6.5 ft]	PDF	
APCS-CN101A-AD	\$39.00	LS Electric CN1 control cable, 20-pin connector to pigtail.	1.0 m [3.2 ft]	PDF	
APCS-CN102A-AD	\$43.00		2.0 m [6.5 ft]	PDF	
APCS-CN103A-AD	\$45.00		3.0 m [9.8 ft]	PDF	



iX7NH Series Accessories

Accessories

iX7NH Terminal Assignment Table



CAUTION: This terminal assignment table is for use with iX7NH drives ONLY. Using this table with non-iX7NH series drives could damage your equipment as terminal assignments are different for each drive series.

APCS-L7NCN1Txxx-AD

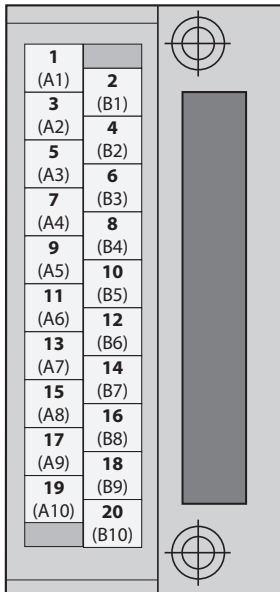

You can download a printable terminal label at <https://www.automationdirect.com/pn/APCS-L7NCN1T-AD>

iX7NH Drive Terminal Assignments					
Terminal	Drive I/O Pin/Wire #	Description	Wire Color	Stripe Color	Number of Stripes
A1	1	DO1	Yellow	Black	1
B1	2	DOCOM	Yellow	Red	1
A2	3	DO2	Yellow	Black	2
B2	4	DO3	Yellow	Red	2
A3	5	AGND	Yellow	Black	3
B3	6	+24V	Yellow	Red	3
A4	7	DI3	Yellow	Black	4
B4	8	DI4	Yellow	Red	4
A5	9	AO	Yellow	Black	5
B5	10	/AO	Yellow	Red	5
A6	11	DI1	White	Black	1
B6	12	DI2	White	Red	1
A7	13	DI5	White	Black	2
B7	14	DI6	White	Red	2
A8	15	A-TLMT	White	Black	3
B8	16	GND	White	Red	3
A9	17	ZO	White	Black	4
B9	18	/ZO	White	Red	4
A10	19	BO	White	Black	5
B10	20	/BO	White	Red	5

Accessories, continued

NOTE: These parts available for sale to North American locations only

iX7NH System STO Cables

Use these pre-made factory cables to easily connect the drive STO connector to a safety relay.

Part Number	Price	Length	Description	Drawing	Compatible Motors
<u>APCS-STO03A-AD</u>	\$40.00	0.3 m [1ft]	LS Electric STO cable, 6-pin connector to pigtail,	<u>PDF</u>	All iX7NH series drives
<u>APCS-STO10A-AD</u>	\$42.00	1m [3.2 ft]		<u>PDF</u>	
<u>APCS-STO30A-AD</u>	\$45.00	3m [9.8 ft]		<u>PDF</u>	



APCS-STO series cable

iX7NH STO Bypass Connector

Replacement STO bypass connector. Note that each drive ships with an APCS-CN6K bypass connector included - this is only needed as a replacement.

Part Number	Price	Description	Compatible Motors
<u>APCS-CN6K-AD</u>	\$19.00	LS Electric STO connector, replacement, 6-pin. For use with all LS Electric iX7 series drives.	All iX7NH series drives



APCS-CN6K-AD

Accessories, continued

NOTE: These parts available for sale to North American locations only

L7C/L7P/iX7NH System Motor Encoder Cables

Part Number	Price	Flex Rated	Length	Gauge	Drawing	Compatible Motors
APCS-EN03ES-AD	\$48.00	N	3m [9.8 ft]	24AWG	PDF	APMC motors with 17-bit incremental encoders (AYK/AYK2 motors)
APCS-EN05ES-AD	\$58.00		5m [16.4 ft]		PDF	
APCS-EN10ES-AD	\$67.00		10m [32.8 ft]		PDF	
APCS-EN20ES-AD	\$79.00		20m [65.6 ft]		PDF	
APCS-EF03ES-AD	\$70.00	Y	3m [9.8 ft]		PDF	
APCS-EF05ES-AD	\$83.00		5m [16.4 ft]		PDF	
APCS-EF10ES-AD	\$116.00		10m [32.8 ft]		PDF	
APCS-EF20ES-AD	\$188.00		20m [65.6 ft]		PDF	
APCS-EN03ES1-AD	\$79.00	N	3m [9.8 ft]	24AWG	PDF	FBL/FCL series motors with 19-bit encoders
APCS-EN05ES1-AD	\$83.00		5m [16.4 ft]		PDF	
APCS-EN10ES1-AD	\$96.00		10m [32.8 ft]		PDF	
APCS-EN20ES1-AD	\$120.00		20m [65.6 ft]		PDF	
APCS-EF03ES1-AD	\$99.00	Y	3m [9.8 ft]		PDF	
APCS-EF05ES1-AD	\$117.00		5m [16.4 ft]		PDF	
APCS-EF10ES1-AD	\$159.00		10m [32.8 ft]		PDF	
APCS-EF20ES1-AD	\$244.00		20m [65.6 ft]		PDF	
APCS-EN03DS1-AD	\$83.00	N	3m [9.8 ft]	24AWG	PDF	APM-FE/APM-FF series motors
APCS-EN05DS1-AD	\$88.00		5m [16.4 ft]		PDF	
APCS-EN10DS1-AD	\$99.00		10m [32.8 ft]		PDF	
APCS-EN20DS1-AD	\$123.00		20m [65.6 ft]		PDF	
APCS-EF03DS1-AD	\$104.00	Y	3m [9.8 ft]		PDF	
APCS-EF05DS1-AD	\$120.00		5m [16.4 ft]		PDF	
APCS-EF10DS1-AD	\$159.00		10m [32.8 ft]		PDF	
APCS-EF20DS1-AD	\$246.00		20m [65.6 ft]		PDF	



APCS-EN series encoder cable



APCS-ENxxxES1 series encoder cable



APC-EF00BS-AD

L7P/iX7NH System Encoder Accessories

Part Number	Price	Description	Compatible Drives
APC-EF00BS-AD	\$20.00	17-pin motor encoder connector.	APM-FE and APM-FF series motors
APCS-BATT36-AD	\$36.00	Encoder battery. One (1) AA ER6V lithium battery with extended leads and an encoder cable connector.	All LS Electric motors with 19-bit encoders



APCS-BATT36-AD

Accessories, *continued*

NOTE: These parts available for sale to North American locations only

L7C/L7P/iX7NH System Motor Brake Power Cables

Part Number	Price	Flex Rated	Length	Gauge	Drawing	Compatible Motors
<u>APCS-BN03QS-AD</u>	\$52.00	N	3m [9.8 ft]	18AWG	<u>PDF</u>	APMC FBL/FCL brake motors (100W – 1kW)
<u>APCS-BN05QS-AD</u>	\$55.00		5m [16.4 ft]		<u>PDF</u>	
<u>APCS-BN10QS-AD</u>	\$61.00		10m [32.8 ft]		<u>PDF</u>	
<u>APCS-BN20QS-AD</u>	\$74.00		20m [65.6 ft]		<u>PDF</u>	
<u>APCS-BF03QS-AD</u>	\$58.00	Y	3m [9.8 ft]		<u>PDF</u>	
<u>APCS-BF05QS-AD</u>	\$63.00		5m [16.4 ft]		<u>PDF</u>	
<u>APCS-BF10QS-AD</u>	\$79.00		10m [32.8 ft]		<u>PDF</u>	
<u>APCS-BF20QS-AD</u>	\$108.00		20m [65.6 ft]		<u>PDF</u>	



APCS-BN series brake cable

iX7NH System Non-Brake Motor Power Cables

Part Number	Price	Flex Rated	Length	Gauge	Drawing	Compatible Motors
APCS-PN03LSX-AD	\$48.00	N	3m [9.8 ft]		PDF	FBL/FCL series motors
APCS-PN05LSX-AD	\$53.00		5m [16.4 ft]		PDF	
APCS-PN10LSX-AD	\$65.00		10m [32.8 ft]		PDF	
APCS-PN20LSX-AD	\$94.00		20m [65.6 ft]		PDF	
APCS-PF03LSX-AD	\$55.00	Y	3m [9.8 ft]	PDF		
APCS-PF05LSX-AD	\$65.00		5m [16.4 ft]	PDF		
APCS-PF10LSX-AD	\$93.00		10m [32.8 ft]	PDF		
APCS-PF20LSX-AD	\$146.00		20m [65.6 ft]	PDF		
APCS-PN03HSX1-AD	\$48.00	N	3m [9.8 ft]		PDF	APM-FE15A series motors without brake
APCS-PN05HSX1-AD	\$55.00		5m [16.4 ft]		PDF	
APCS-PN10HSX1-AD	\$72.00		10m [32.8 ft]		PDF	
APCS-PN20HSX1-AD	\$108.00		20m [65.6 ft]		PDF	
APCS-PF03HSX1-AD	\$56.00	Y	3m [9.8 ft]	PDF		
APCS-PF05HSX1-AD	\$68.00		5m [16.4 ft]	PDF		
APCS-PF10HSX1-AD	\$100.00		10m [32.8 ft]	PDF		
APCS-PF20HSX1-AD	\$158.00		20m [65.6 ft]	PDF		
APCS-PN03HSX-AD	\$44.00	N	3m [9.8 ft]		PDF	APM-FE16D and APM-FE22D series motors without brake
APCS-PN05HSX-AD	\$53.00		5m [16.4 ft]		PDF	
APCS-PN10HSX-AD	\$74.00		10m [32.8 ft]		PDF	
APCS-PN20HSX-AD	\$116.00		20m [65.6 ft]		PDF	
APCS-PF03HSX-AD	\$57.00	Y	3m [9.8 ft]	PDF		
APCS-PF05HSX-AD	\$74.00		5m [16.4 ft]	PDF		
APCS-PF10HSX-AD	\$116.00		10m [32.8 ft]	PDF		
APCS-PF20HSX-AD	\$200.00		20m [65.6 ft]	PDF		
APCS-PN03ISX-AD	\$49.00	N	3m [9.8 ft]		PDF	APM-FF35D motors without brake
APCS-PN05ISX-AD	\$57.00		5m [16.4 ft]		PDF	
APCS-PN10ISX-AD	\$79.00		10m [32.8 ft]		PDF	
APCS-PN20ISX-AD	\$120.00		20m [65.6 ft]		PDF	
APCS-PF03ISX-AD	\$63.00	Y	3m [9.8 ft]	PDF		
APCS-PF05ISX-AD	\$80.00		5m [16.4 ft]	PDF		
APCS-PF10ISX-AD	\$124.00		10m [32.8 ft]	PDF		
APCS-PF20ISX-AD	\$213.00		20m [65.6 ft]	PDF		

NOTE: These parts available for sale to North American locations only



APCS-PxxLSX series power cable



APCS-PxxHSX1 series power cable



APCS-PxxHSX series power cable

Accessories, continued

iX7NH System Brake Motor Power Cables

Part Number	Price	Flex Rated	Length	Gauge	Drawing	Compatible Motors
Note: For FBL/FCL 100W–1kW motors with brake, use the power cables on the previous page AND separate brake cable APCS-BxxxQS-AD from page tSRV-82. This is for FBL/FCL motors only. FE and FF motors have brake wiring incorporated into the power cable (below).						
APCS-PN03NBX1-AD	\$58.00	N	3m [9.8 ft]		PDF	APM-FE15A series motors with brakes
APCS-PN05NBX1-AD	\$68.00		5m [16.4 ft]		PDF	
APCS-PN10NBX1-AD	\$94.00		10m [32.8 ft]		PDF	
APCS-PN20NBX1-AD	\$144.00		20m [65.6 ft]		PDF	
APCS-PF03NBX1-AD	\$72.00	Y	3m [9.8 ft]		PDF	
APCS-PF05NBX1-AD	\$91.00		5m [16.4 ft]		PDF	
APCS-PF10NBX1-AD	\$139.00		10m [32.8 ft]		PDF	
APCS-PF20NBX1-AD	\$237.00		20m [65.6 ft]		PDF	
APCS-PN03NBX-AD	\$51.00	N	3m [9.8 ft]		PDF	APM-FE16D and APM-FE22D series motors with brakes
APCS-PN05NBX-AD	\$61.00		5m [16.4 ft]		PDF	
APCS-PN10NBX-AD	\$86.00		10m [32.8 ft]		PDF	
APCS-PN20NBX-AD	\$137.00		20m [65.6 ft]		PDF	
APCS-PF03NBX-AD	\$67.00	Y	3m [9.8 ft]		PDF	
APCS-PF05NBX-AD	\$89.00		5m [16.4 ft]		PDF	
APCS-PF10NBX-AD	\$137.00		10m [32.8 ft]		PDF	
APCS-PF20NBX-AD	\$243.00		20m [65.6 ft]		PDF	
APCS-PN03PBX-AD	\$70.00	Y	3m [9.8 ft]		PDF	APM-FF35D series motors with brakes
APCS-PN05PBX-AD	\$82.00		5m [16.4 ft]		PDF	
APCS-PN10PBX-AD	\$117.00		10m [32.8 ft]		PDF	
APCS-PN20PBX-AD	\$184.00		20m [65.6 ft]		PDF	
APCS-PF03PBX-AD	\$89.00	N	3m [9.8 ft]		PDF	
APCS-PF05PBX-AD	\$117.00		5m [16.4 ft]		PDF	
APCS-PF10PBX-AD	\$182.00		10m [32.8 ft]		PDF	
APCS-PF20PBX-AD	\$315.00		20m [65.6 ft]		PDF	



APCS-PxxNBX1 series power cable



APCS-PxxNBX series power cable



APCS-PxxPBX series power cable

LS ELECTRIC L7C Series AC Servo Systems

Accessories, *continued*

NOTE: These parts available for sale to North American locations only

L7C System Motor Power Cables

Part Number	Price	Flex Rated	Length	Gauge	Drawing	Compatible Motors
APCS-PN03LSC-AD	\$40.00	N	3m [9.8 ft]	18AWG	PDF	APMC FBL/FCL motors (100W – 1kW) used with L7C drives
APCS-PN05LSC-AD	\$48.00		5m [16.4 ft]		PDF	
APCS-PN10LSC-AD	\$62.00		10m [32.8 ft]		PDF	
APCS-PN20LSC-AD	\$85.00		20m [65.6 ft]		PDF	
APCS-PF03LSC-AD	\$52.00	Y	3m [9.8 ft]		PDF	
APCS-PF05LSC-AD	\$68.00		5m [16.4 ft]		PDF	
APCS-PF10LSC-AD	\$96.00		10m [32.8 ft]		PDF	
APCS-PF20LSC-AD	\$151.00		20m [65.6 ft]		PDF	



APCS-PN series motor cable

L7P System Non-Brake Motor Power Cables

Part Number	Price	Flex Rated	Length	Gauge	Drawing	Compatible Motors
APCS-PN03LS-AD	\$42.00	N	3m [9.8 ft]	18AWG	PDF	FBL/FCL series motors
APCS-PN05LS-AD	\$46.00		5m [16.4 ft]		PDF	
APCS-PN10LS-AD	\$57.00		10m [32.8 ft]		PDF	
APCS-PN20LS-AD	\$80.00		20m [65.6 ft]		PDF	
APCS-PF03LS-AD	\$53.00	Y	3m [9.8 ft]		PDF	
APCS-PF05LS-AD	\$62.00		5m [16.4 ft]		PDF	
APCS-PF10LS-AD	\$90.00		10m [32.8 ft]		PDF	
APCS-PF20LS-AD	\$145.00		20m [65.6 ft]		PDF	
APCS-PN03HS-AD	\$37.00	N	3m [9.8 ft]	14AWG	PDF	APM-FE series motors without brake
APCS-PN05HS-AD	\$44.00		5m [16.4 ft]		PDF	
APCS-PN10HS-AD	\$62.00		10m [32.8 ft]		PDF	
APCS-PN20HS-AD	\$98.00		20m [65.6 ft]		PDF	
APCS-PF03HS-AD	\$52.00	Y	3m [9.8 ft]		PDF	
APCS-PF05HS-AD	\$66.00		5m [16.4 ft]		PDF	
APCS-PF10HS-AD	\$106.00		10m [32.8 ft]		PDF	
APCS-PF20HS-AD	\$184.00		20m [65.6 ft]		PDF	
APCS-PN03IS-AD	\$50.00	N	3m [9.8 ft]	10AWG	PDF	230VAC APM-FF35D and 460VAC APM-FFP35D motors without brakes
APCS-PN05IS-AD	\$64.00		5m [16.4 ft]		PDF	
APCS-PN10IS-AD	\$98.00		10m [32.8 ft]		PDF	
APCS-PN20IS-AD	\$167.00		20m [65.6 ft]		PDF	
APCS-PF03IS-AD	\$64.00	Y	3m [9.8 ft]		PDF	
APCS-PF05IS-AD	\$85.00		5m [16.4 ft]		PDF	
APCS-PF10IS-AD	\$140.00		10m [32.8 ft]		PDF	
APCS-PF20IS-AD	\$252.00		20m [65.6 ft]		PDF	
APCS-PN03JS-AD	\$58.00	N	3m [9.8 ft]	10AWG	PDF	230VAC APM-FF55D motors without brake
APCS-PN05JS-AD	\$77.00		5m [16.4 ft]		PDF	
APCS-PN10JS-AD	\$120.00		10m [32.8 ft]		PDF	
APCS-PN20JS-AD	\$220.00		20m [65.6 ft]		PDF	
APCS-PF03JS-AD	\$83.00	Y	3m [9.8 ft]		PDF	
APCS-PF05JS-AD	\$116.00		5m [16.4 ft]		PDF	
APCS-PF10JS-AD	\$203.00		10m [32.8 ft]		PDF	
APCS-PF20JS-AD	\$376.00		20m [65.6 ft]		PDF	
APCS-PF03JS1-AD	\$69.00	Y	3m [9.8 ft]	12AWG	PDF	460VAC APM-FFP55D and APM-FFP75D motors without brakes
APCS-PF05JS1-AD	\$95.00		5m [16.4 ft]		PDF	
APCS-PF10JS1-AD	\$159.00		10m [32.8 ft]		PDF	
APCS-PF20JS1-AD	\$289.00		20m [65.6 ft]		PDF	
APCS-PN03JS2-AD	\$99.00	N	3m [9.8 ft]	8AWG	PDF	230VAC APM-FF75D motors without brake
APCS-PN05JS2-AD	\$139.00		5m [16.4 ft]		PDF	
APCS-PN10JS2-AD	\$235.00		10m [32.8 ft]		PDF	
APCS-PN20JS2-AD	\$427.00		20m [65.6 ft]		PDF	
APCS-PF03JS2-AD	\$144.00	Y	3m [9.8 ft]		PDF	
APCS-PF05JS2-AD	\$210.00		5m [16.4 ft]		PDF	
APCS-PF10JS2-AD	\$374.00		10m [32.8 ft]		PDF	
APCS-PF20JS2-AD	\$703.00		20m [65.6 ft]		PDF	

NOTE: These parts available for sale to North American locations only

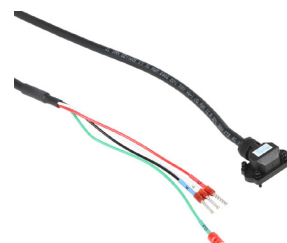

APCS-PxxLS series power cable



APCS-PxxHS series power cable



APCS-PxxIS series power cable



APCS-PxxJS series power cable

Accessories, continued

L7P System Brake Motor Power Cables

Part Number	Price	Flex Rated	Length	Gauge	Drawing	Compatible Motors		
<p>Note: For FBL/FCL 100W-1kW motors with brake, use the power cables on page tMNC-234 (APCS-PxxxLS-AD) AND separate brake cable APCS-BxxxQS-AD from page tMNC-232. This is for FBL/FCL motors only. FE and FF motors have brake wiring incorporated into the power cable (below).</p>								
APCS-PN03NB-AD	\$49.00	N	3m [9.8 ft]	14AWG	PDF	230VAC and 460 VAC APM-FE series motors with brakes		
APCS-PN05NB-AD	\$58.00		5m [16.4 ft]		PDF			
APCS-PN10NB-AD	\$84.00		10m [32.8 ft]		PDF			
APCS-PN20NB-AD	\$137.00		20m [65.6 ft]		PDF			
APCS-PF03NB-AD	\$71.00	Y	3m [9.8 ft]		PDF			
APCS-PF05NB-AD	\$95.00		5m [16.4 ft]		PDF			
APCS-PF10NB-AD	\$153.00		10m [32.8 ft]		PDF			
APCS-PF20NB-AD	\$274.00		20m [65.6 ft]		PDF			
APCS-PN03PB-AD	\$69.00	N	3m [9.8 ft]		PDF	230VAC APM-FF35D and 460VAC APM-FFP35D motors with brakes		
APCS-PN05PB-AD	\$87.00		5m [16.4 ft]		PDF			
APCS-PN10PB-AD	\$133.00		10m [32.8 ft]		PDF			
APCS-PN20PB-AD	\$229.00		20m [65.6 ft]		PDF			
APCS-PF03PB-AD	\$88.00	Y	3m [9.8 ft]	PDF				
APCS-PF05PB-AD	\$120.00		5m [16.4 ft]	PDF				
APCS-PF10PB-AD	\$198.00		10m [32.8 ft]	PDF				
APCS-PF20PB-AD	\$359.00		20m [65.6 ft]	PDF				
APCS-PN03LB-AD	\$66.00	N	3m [9.8 ft]	8AWG	PDF	230VAC APM-FF55D motors with brake		
APCS-PN05LB-AD	\$84.00		5m [16.4 ft]		PDF			
APCS-PN10LB-AD	\$131.00		10m [32.8 ft]		PDF			
APCS-PN20LB-AD	\$226.00		20m [65.6 ft]		PDF			
APCS-PF03LB-AD	\$96.00	Y	3m [9.8 ft]		PDF			
APCS-PF05LB-AD	\$136.00		5m [16.4 ft]		PDF			
APCS-PF10LB-AD	\$235.00		10m [32.8 ft]		PDF			
APCS-PF20LB-AD	\$435.00		20m [65.6 ft]		PDF			
APCS-PF03LB1-AD	\$81.00	Y	3m [9.8 ft]		12AWG	PDF	460VAC APM-FFP55D and APM-FFP75D motors with brakes	
APCS-PF05LB1-AD	\$110.00		5m [16.4 ft]			PDF		
APCS-PF10LB1-AD	\$187.00		10m [32.8 ft]			PDF		
APCS-PF20LB1-AD	\$341.00		20m [65.6 ft]			PDF		
APCS-PN03LB2-AD	\$110.00	N	3m [9.8 ft]	8AWG		PDF		230VAC APM-FF75D motors with brake
APCS-PN05LB2-AD	\$151.00		5m [16.4 ft]			PDF		
APCS-PN10LB2-AD	\$255.00		10m [32.8 ft]			PDF		
APCS-PN20LB2-AD	\$460.00		20m [65.6 ft]			PDF		
APCS-PF03LB2-AD	\$159.00	Y	3m [9.8 ft]		PDF			
APCS-PF05LB2-AD	\$232.00		5m [16.4 ft]		PDF			
APCS-PF10LB2-AD	\$410.00		10m [32.8 ft]		PDF			
APCS-PF20LB2-AD	\$772.00		20m [65.6 ft]		PDF			



APCS-PxxNB series power cable



APCS-PxxPB series power cable



APCS-PxxLB series power cable

Accessories, continued





LS Drive System Replacement Connectors

Part Number	Price	Description	Compatible Drives	Image
<u>5452573</u>	\$6.50	AutomationDirect replacement drive power connector.	All L7C drives	
<u>APC-CN1NNA-AD</u>	\$17.50	LS solder-type CN1 50-pin Electric I/O connector.	All L7C and L7P series drives	
<u>APC-CN2NNA-AD</u>	\$15.00	LS Electric I/O connector, replacement, 20-pin.	All iX7NH series drives	
<u>APC-CN3NNA-AD</u>	\$17.50	LS Electric solder-type CN2 14-pin drive encoder connector.	All L7C, L7P, and iX7NH series drives	
<u>APCS-CN6K-AD</u>	\$19.00	LS Electric STO connector, replacement, 6-pin. For use with all LS Electric iX7 series drives.	All iX7NH series drives	
<u>IX7-CON-A</u>	\$19.00	AutomationDirect drive power connector, replacement, 11-pin. Note: Do not wire to pin 4 (the "N" terminal).	iX7NH series drives, 400W, 750W, and 1kW	
<u>IX7-CON-B</u>	\$19.00	AutomationDirect drive power connector for motor power, replacement, 4-pin.	iX7NH series drives, 400W, 750W, and 1kW	
<u>IX7-CON-C</u>	\$9.00	AutomationDirect drive power connector release, replacement.	iX7NH series drives, 400W, 750W, and 1kW	
<u>IX7-CON-D</u>	\$19.00	AutomationDirect drive power connector for motor power, replacement, 4-pin	iX7NH series drives, 2kW and 3.5 kW	
<u>IX7-CON-E</u>	\$19.00	AutomationDirect drive control power connector, replacement, 5-pin.	iX7NH series drives, 2kW and 3.5 kW	
<u>IX7-CON-F</u>	\$19.00	AutomationDirect drive main power connector, replacement, 6-pin.	iX7NH series drives, 2kW and 3.5 kW	
<u>L7P-CON-A</u>	\$15.00	Replacement 11-pin drive power connector. Do not wire to pin 4 (the "N" terminal)	L7PA series 230VAC 400W and 1kW drives	
<u>L7P-CON-B</u>	\$8.00	Replacement 3-pin drive power connector.	L7PA series 230VAC 400W and 1kW drives	

Continued on next page

Accessories, *continued*

LS Drive System Replacement Connectors, *continued*

Part Number	Price	Description	Compatible Drives	Image
<u>L7P-CON-C</u>	\$20.00	Replacement 11-pin drive power connector.	L7PB series 460VAC 1kW drives, all L7P series 2kW and 3.5 kW drives	
<u>L7P-CON-D</u>	\$7.50	Replacement 3-pin drive power connector.	L7PB series 460VAC 1kW drives, all L7P series 2kW and 3.5 kW drives	
<u>L7P-CON-E</u>	\$0.50	Drive analog monitor crimp pins (24-48 AWG), package of 5.	All L7P and iX7NH drives. Requires L7P-CON-F	
<u>L7P-CON-F</u>	\$2.00	Drive analog monitor 4-pin crimp connector.	All L7P and iX7NH drives. Requires L7P-CON-E	
<u>L7P-CON-G</u>	\$2.00	Drive analog monitor 4-pin IDC connector (26AWG).	All L7P and iX7NH series drives	

Accessories, continued

L7C/L7P/iX7NH System Braking Resistors

Use external braking resistors to provide additional regenerative capacity and to dissipate heat away from the servo drive.

Part Number	Price	Description	Drawing	Compatible Drive Series	Compatible Drive Models
<u>APCS-140R50-AD</u>	\$18.50	LS Electric 140W 30Ω encapsulated braking resistor	<u>PDF</u>	All 400W LS drives	L7CA004U-AD L7PA004U-AD IX7NHA004U-AD
<u>APCS-300R30-AD</u>	\$24.00	LS Electric 300W 30Ω encapsulated braking resistor	<u>PDF</u>	All 230VAC 750W and 1kW LS drives	L7CA010U-AD L7PA010U-AD IX7NHA008U-AD IX7NHA010U-AD
<u>APC-600R30-AD</u>	\$42.00	LS Electric 600W 30Ω encapsulated braking resistor.	<u>PDF</u>	All 230VAC 2.2 kW and 3.5 kW LS drives	L7PA020U-AD L7PA035U-AD IX7NHA020U-AD IX7NHA035U-AD
<u>APC-600R28-AD</u>	\$64.00	LS Electric 600W 28Ω encapsulated braking resistor.	<u>PDF</u>	All 230VAC 5.5 kW and 7.5 kW LS drives	L7PA050U-AD L7PA075U-AD
<u>APCS-300R82-AD</u>	\$16.00	LS Electric 300W 82Ω encapsulated braking resistor.	<u>PDF</u>	All 460VAC 1kW LS drives	L7PB010U-AD
<u>APCS-600R140-AD</u>	\$42.00	LS Electric 600W 140Ω encapsulated braking resistor.	<u>PDF</u>	Alternate resistor for 460VAC 2.2 kW and 3.5 kW LS drives	Alternate resistor for L7PB020U-AD L7PB035U-AD
<u>APCS-600R75-AD</u>	\$42.00	LS Electric 600W 75Ω encapsulated braking resistor.	<u>PDF</u>	All 460VAC 2.2, 3.5, 5.5, and 7.5 kW LS drives	L7PB020U-AD L7PB035U-AD L7PB050U-AD L7PB075U-AD



NOTE: 600W resistors require customer-supplied M5-.8 bolts and cable lugs for connection.



APCS-140R50-AD

LS ELECTRIC AC Servo Systems Accessories

Servo System EMI Filters

Input EMI filters reduce electromagnetic interference or noise on the input side of the servo drive. They are required for CE compliance and recommended for installations prone to or sensitive to electromagnetic interference.

Part Number	Price	Rating	Description	Drawing	Compatible Drive Series	Compatible Drive Models
<u>TB1-10A0D0</u>	\$67.00	10A	LS Electric EMI input filter, 250 VAC, 1-phase, 10A, panel mount, EMI/RFI filtering, 2-stage, drive rated, standard performance, screw terminals. For use with 1-phase AC drives.	<u>PDF</u>	All L7C series drives	L7CA004U-AD L7CA010U-AD
<u>TB6-B010LBEI</u>	\$86.00	10A	LS Electric EMI input filter, 550VAC, 3-phase, panel mount, EMI/RFI filtering, drive rated, standard performance, screw terminals.	<u>PDF</u>	L7P and iX7NH 400W through 1kW drives	L7PA004U-AD L7PA010U-AD L7PB010U-AD IX7NHA004U-AD IX7NHA008U-AD IX7NHA010U-AD
<u>TB6-B020NBDC</u>	\$110.00	20A		<u>PDF</u>	L7P 460V 2kW and 3.5 kW drives	L7PB020U-AD L7PB035U-AD
<u>TB6-B030NBDC</u>	\$104.00	30A		<u>PDF</u>	L7P and iX7NH 230V: 2kW, 3.5 kW and L7P 460V: 5kW	L7PA020U-AD L7PA035U-AD L7PB050U-AD IX7NHA020U-AD IX7NHA035U-AD
<u>TB6-B040AS</u>	\$180.00	40A		<u>PDF</u>	L7P 230V: 5kW 460V: 7.5 kW	L7PA050U-AD L7PB075U-AD
<u>TB6-B060LAS</u>	\$313.00	50A		<u>PDF</u>	L7P 230V: 7.5 kW drives	L7PA075U-AD



TB1-10A0D0



TB6-B010LBEI

Accessories, continued

NOTE: These parts available for sale to North American locations only

L7C/L7P/iX7NH/PHOX System Planetary Gearboxes

Precision planetary gearboxes can increase the torque output of servo systems while reducing the reflected load inertia for higher response. Gearboxes offer high stiffness, high efficiency, and very quiet operation. Input motor shaft clamp, oversized output shaft key, and mounting hardware are included for mating to LS Electric motors.

Features:

- Maintenance free (no need to replace lubrication)
- IP65
- Operating temperature range of -10°C to +90°C [14°F to 194°F]
- Uses VIGO Grease RE #0



MSS Series Planetary Gearbox

MSS Series Planetary Gearbox Specifications										
Model	96200004	96200005	96200103	96200007	96200008	96200257	96200373	96200378	96200393	96200459
Manufacturer Part Number	MSS0601A-005KS-B3110103C14	MSS0601A-010KS-B3110103C14	MSS0902B-020KS-B3110103C14	MSS0901A-005KS-C3110103C19	MSS0901A-010KS-C3110103C19	MSS1152B-020KS-C4120103C19	MSS0901A-005KS-C4120103C19	MSS0901A-010KS-C4120103C19	MSS1152B-020KS-C4120103C19	MSS1151A-005KS-D3110103C22
Compatible Motors	APMC-FBL series 100, 200, 300, and 400 W motors			APMC FCL series 750W and 1kW motors			APM-FE series 900W and 1.5 kW motors			APM-FE series 1.6 kW motors
Price	\$288.00	\$296.00	\$528.00	\$387.00	\$387.00	\$762.00	\$350.00	\$350.00	\$699.00	\$499.00
Drawing	PDF	PDF	PDF	PDF	PDF	PDF	PDF	PDF	PDF	PDF
Ratio	5:1	10:1	20:1	5:1	10:1	20:1	5:1	10:1	20:1	5:1
Nominal Output Torque	54 N·m	42 N·m	143 N·m	160 N·m	121 N·m	295 N·m	160 N·m	121 N·m	295 N·m	332 N·m
Inertia	0.13 kg/cm ²	0.13 kg/cm ²	0.13 kg/cm ²	0.48 kg/cm ²	0.44 kg/cm ²	0.48 kg/cm ²	0.48 kg/cm ²	0.44 kg/cm ²	0.48 kg/cm ²	2.81 kg/cm ²
Output Shaft Diameter	16mm	16mm	22mm	22mm	22mm	32mm	22mm	22mm	32mm	32mm
Stage	1	1	2	1	1	2	1	1	2	1
Frame	60mm	60mm	90mm	90mm	90mm	115mm	90mm	90mm	115mm	115mm
Nominal Input Speed (rpm)	5,000	5,000	4,000	4,000	4,000	4,000	4,000	4,000	4,000	4,000
Max Input Speed (rpm)	10,000	10,000	8,000	8,000	8,000	8,000	8,000	8,000	8,000	8,000
Emergency Stop Torque	3 times nominal output torque									
Noise (dB)	≤54	≤54	≤56	≤56	≤56	≤59	≤56	≤56	≤59	≤59
Efficiency (%)	≥97	≥97	≥94	≥97	≥97	≥94	≥97	≥97	≥94	≥97
Backlash (Arcmin)	≤7	≤7	≤9	≤7	≤7	≤9	≤7	≤7	≤9	≤7
Max Radial Load (N)	1,280	1,280	3,200	3,200	3,200	6,800	3,200	3,200	6,800	6,800
Max Axial Load (N)	690	690	1,600	1,600	1,600	3,400	1,600	1,600	3,400	3,400
Service Life (Hours)	20,000 (10,000 under continuous operation)									
Continued on next page										



LS Electric AC Servo Systems

Accessories, continued

MSS Series Planetary Gearbox Specifications											
Model	96200464	96200479	96200010	96200011	96200445	96200013	96200014	96200701	96200016	96200017	96200862
Manufacturer Part Number	MSS1151A-010KS-D3110103C22	MSS1422B-020KS-D3110103C22	MSS1151A-005KS-D3110103C24	MSS1151A-010KS-D3110103C24	MSS1422B-020KS-D3110103C24	MSS1421A-005KS-E3110103C35	MSS1421A-010KS-E3110103C35	MSS1802B-020KS-E3110103C35	MSS1801A-005KS-F3110103C42	MSS1801A-010KS-F3110103C42	MSS1802A-015KS-F3110103C42
Compatible Motors	APM-FE series 1.6 kW motors		APM-FE series 2.2 kW motors			APM-FF series 3.5 kW and 5.5 kW motors			APM-FF series 7.5 kW motors		
Price	\$499.00	\$1,030.00	\$499.00	\$499.00	\$1,030.00	\$770.00	\$770.00	\$1,850.00	\$1,480.00	\$1,480.00	\$1,850.00
Drawing	PDF	PDF	PDF	PDF	PDF	PDF	PDF	PDF	PDF	PDF	PDF
Ratio	10:1	20:1	5:1	10:1	20:1	5:1	10:1	20:1	5:1	10:1	15:1
Nominal Output Torque	262 N·m	295 N·m	332 N·m	262 N·m	295 N·m	634 N·m	500 N·m	1060 N·m	1195 N·m	960 N·m	897 N·m
Inertia	2.59 kg/cm ²	2.81 kg/cm ²	2.81 kg/cm ²	2.59 kg/cm ²	2.81 kg/cm ²	7.52 kg/cm ²	7.05 kg/cm ²	7.52 kg/cm ²	24.29 kg/cm ²	23.51 kg/cm ²	24.29 kg/cm ²
Output Shaft Diameter	32mm	40mm	32mm	32mm	40mm	40mm	40mm	55mm	55mm	55mm	55mm
Stage	1	2	1	1	2	1	1	2	1	1	2
Frame	115mm	142mm	115mm	115mm	142mm	142mm	142mm	180mm	180mm	180mm	180mm
Nominal Input Speed (rpm)	4,000	3,000	4,000	4,000	3,000	3,000	3,000	3,000	3,000	3,000	3,000
Max Input Speed (rpm)	8,000	6,000	8,000	8,000	6,000	6,000	6,000	6,000	6,000	6,000	6,000
Emergency Stop Torque	3 times nominal output torque										
Noise (dB)	≤59	≤62	≤59	≤59	≤62	≤62	≤62	≤64	≤64	≤64	≤64
Efficiency (%)	≥97	≥94	≥97	≥97	≥94	≥97	≥97	≥94	≥97	≥97	≥94
Backlash (Arcmin)	≤7	≤9	≤7	≤7	≤9	≤7	≤7	≤9	≤7	≤7	≤9
Max Radial Load (N)	6,800	9,300	6,800	6,800	9,300	9,300	9,300	15,100	15,100	15,100	15,100
Max Axial Load (N)	3,400	4,500	3,400	3,400	4,500	4,500	4,500	7,500	7,500	7,500	7,500
Service Life (Hours)	20,000 (10,000 under continuous operation)										



AC Servo Systems

Drive features

- Power:
 - 1 phase 110VAC: 100W-2kW
 - 1 phase 220VAC: 100W-2kW
 - 3 phase 220VAC: 100W-15kW
 - 3 phase 460VAC: 400W-15kW
- Fully digital with up to 3.1 kHz bandwidth velocity loop response
- Easy setup and diagnostics with built-in keypad/display or the SureServo2 Pro PC-based software
- Field upgradeable firmware ensures the drive can always be upgraded to the latest operating system
- Communications include:
 - Serial Modbus (native/built-in)
 - Optional Modbus TCP card
 - Optional Ethernet/IP card (this card can use implicit and explicit messaging. SureServo2 Pro software can generate an EDS file to transfer custom data between PLC and drive)
- Command options include:
 - \pm 10V torque or velocity command
 - Pulse train or master encoder position command (accepts line driver or open collector) with electronic gearing
 - Powerful built-in motion controller for position control using 99 preset positions (enter these during development, or send them through the communications options above during runtime)
 - Internal sequencing for position/speed



commands, registration (capture/compare), electronic camming, homing (10 different options), Jumps, and arithmetic statements.

- The 3.1 kHz bandwidth allows for high-level automatic tuning. Several modes of tuning are available including Auto Tune that can estimate the load inertia and fine-tune the system when all the loads are attached.
- Optically isolated digital inputs (10) and outputs (6), analog outputs for monitor signals (2), and line driver output for encoder (with scalable resolution).
- Other Features:
 - Secondary/Auxiliary encoder feedback (for true closed loop control)
 - Registration ability
 - Analog positioning
 - Safe Torque Off (STO) included - so no need for large, bulky contactors to disconnect power from the drive in E-stop situations
 - Absolute Encoder operation (with optional encoder battery backup)
 - Electronic camming (you can define the cam with SureServo2 Pro software or you can import an Excel spreadsheet)
 - Advanced Scope feature that can monitor a variety of command and status signals, including output speed, torque, power, etc.

Motor features

- Low inertia models:
 - 100W, 200W, 400W, 750W, 1kW, 1.5 kW, and 2kW
 - Speeds up to 6,000 rpm
- Medium inertia models:
 - 1kW, 1.5 kW, 2kW, and 3kW
 - Speeds up to 3,000 rpm
- High inertia models:
 - 3kW, 4.5 kW, 5.5 kW, 7.5 kW, 11kW, and 15kW
 - Speeds up to 3,000 rpm
- Permanent magnet 3-phase synchronous motor
- Keyed drive shafts support clamp-on style couplings or key-style couplings
- Integrated encoder with 16,777,216 encoder pulses/revolution plus marker pulse (once per revolution)
- Optional 24 VDC spring-set holding brakes (xxxxB series motors)
- Standard hook-up cables for motor power, encoder, and brake (separate brake cable for brake motors 230V systems 5.5kW and larger or 460V systems 11kW and larger)
- Motor cables available in standard or flex-rated lengths of 3, 5, 10, and 20m
- Standard 50-pin DIN-rail mounted break-out kit for the drive's CN1 connector (with screw terminal connections), or 20-pin spring clamp terminal block (limited I/O) that mounts directly to the drive

SureServo2 tuning technology

The SureServo2 drive closes the loop on current, velocity, and position (depending on control mode selection). The 3.1 kHz bandwidth in the drive assures precise speed and current control and easy tuning. Proportional gain, integral gain and compensation, feed forward compensation, command low pass filter, and five (5) notch filters for resonance suppression are available. Auto Tuning has been greatly improved and can easily tune systems with as much as 60:1 inertia mismatch.

There is an inertia estimation function that analyzes the motor and load to measure how much inertia is coupled to the motor.

The drive has several tuning methods available:

- One Touch Auto Tuning—the drive tunes the motor without any motion (static motor/system analysis)
- Normal Auto Tuning—the drive tunes the load while an external controller or the drive's internal indexer provides point-to-point moves
- Assisted Tuning—3 modes where the drive tunes the motor while moving. The user can adjust responsiveness while the drive is analyzing the system
- Manual Tuning—20+ parameters are available to give power users the ultimate flexibility to tune their systems.

SureServo2 Built-in motion controller

While the SureServo2 drives can accept traditional commands from host controls, they can also provide their own internal motion control. For example, up to 99 index moves can be pre-defined and stored in the drive and then selected and executed using digital inputs (inputs as events or inputs used as a multiplexer) or communication (serial Modbus, Modbus TCP, or Ethernet/IP). The index profiles can also be changed while in-process with digital events or via comms. The internal motion can consist of incremental or absolute moves, and can be sequenced internally with delays in between the moves or moves can be linked together so they are processed one after the other.

Multi-axis systems can be controlled via digital inputs, or serial/Ethernet communication. The motion can be commanded from a powerful external controller that sends out high speed pulses to each drive, or the motion can be initiated by a low-level controller (the simplest CLICK PLC) since each drive has a powerful motion controller inside. Applications include press feeds, auger fillers, rotary tables, robots for pick and place, test or assembly operations, drilling, cutting, tapping, and similar applications using simple index moves for single or multi-axis motion.

SureServo2

Optional Holding Brake

Each SureServo2 motor rating can be ordered with an optional 24VDC spring-set holding brake that holds the motor in place when power is removed.

SureGear® Precision Gearboxes for Servo motors

Inertia balancing issue in your design?

The SureGear PGA series easily mates to SureServo2 motors. Everything you need to mount your SureServo2 motor is included!



- Four gear ratios available (5, 10, 15, 25:1)
- Mounting hardware included for attaching to SureServo2 motors
- Industry-standard mounting dimensions
- Thread-in mounting style
- Best-in-class backlash (5 arc-min)
- 5-year warranty

How to select and apply SureServo2 systems

The primary purpose of the AC servo system is to precisely control the motion of the load. The most fundamental considerations in selecting the servo system are “reflected” load inertia, servo system maximum speed requirement, servo system continuous torque requirement, and servo system peak torque requirement. In a retrofit application, select the largest torque SureServo2 system that most closely matches these parameters for the system being replaced. In a new application, these parameters should be determined through calculation and/or measurement. SureServo2 Pro has the ability to measure the load (reflected) inertia and accurately measure the motor torque output.

AutomationDirect has teamed with Copperhill Technologies to provide free servo-sizing software. “VisualSizer-SureServo” software will assist in determining the correct motor and drive for your application by calculating the reflected load inertia and required speed and torque based on the load configuration. “VisualSizer-SureServo” software can be downloaded from www.automationdirect.com on the store page for your drive.

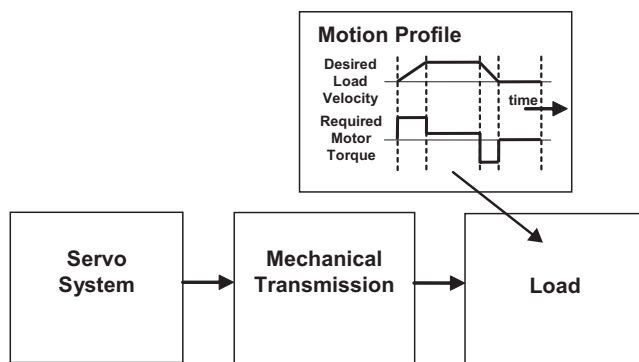

1. “Reflected” load inertia

The inertia of everything attached to the servo motor driveshaft needs to be considered and the total “reflected” inertia needs to be determined. This means that all elements of any mechanical transmission and load inertia need to be translated into an equivalent inertia as if attached directly to the motor driveshaft. The ratio of “reflected” load inertia to motor inertia needs to be carefully considered when selecting the servo system.

In general, applications that need high response or bandwidth will benefit from keeping the ratio of load inertia to motor inertia as low as possible and ideally under 10:1. Systems with ratios as high as 200:1 can be implemented, but corresponding lower bandwidth or responsiveness must be accepted. The servo response including the attached load inertia is determined by the servo tuning. SureServo2 systems may be tuned manually, fully Automatically, or via a hybrid mode where the software tunes the system with input for system responsiveness from the user.

2. Torque and speed

With knowledge of the motion profile and any mechanical transmission between the motor and load, calculations can be made to determine the required servo motor continuous torque, peak torque, and maximum motor speed. The required amount of continuous torque must fall inside the continuous operating region of the system torque-speed curve (you can check the continuous torque at the average speed of the motion profile). The required amount of peak torque must also fall within the servo system’s intermittent operating region of the system torque-speed curve (you need to check this value at the required maximum speed or torque). If you have a SureServo2 system, these values are easily captured and recorded with the Scope feature built into SureServo2 Pro. If you are designing the system, use VisualSizer to define the system and calculate expected inertia and required power.

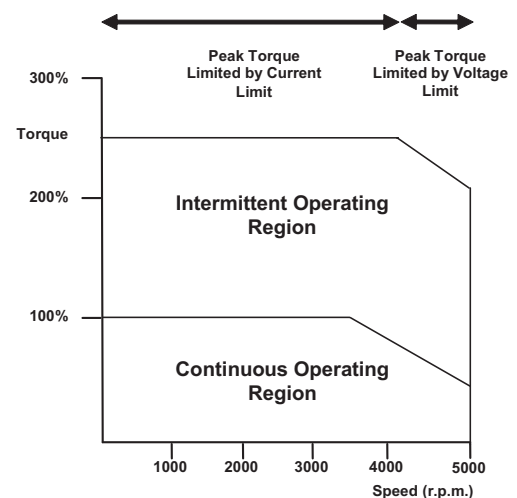



AC Servo Systems

Application tip - coupling considerations

The SureServo2 motors have keyed shafts that can be used with keyed couplings or with clamp-on or compression style couplings. "Servo-grade" clamp-on or compression style couplings are usually the best choice when you consider the stiffness, torque rating, and inertia. Higher stiffness

(lb-in/radian) is needed for better response but there is a trade-off between the stiffness and the added inertia of the coupling. Concerning the torque rating of the coupling, use a safety factor of 1.25 over the SureServo2 **peak** torque requirement of your application.

Available Couplings

Mechanical transmissions

Common mechanical transmissions include leadscrews, rack & pinion mechanisms, conveyors, gears, and timing belts. The use of leadscrew, rack & pinion, or conveyor are common ways to translate the rotary motion of the servo motor into linear motion of the load. The use of a speed reducer such as a gearbox or timing belt can be very beneficial as follows:

1. Reduction of reflected load inertia

As a general rule, it is beneficial to keep the reflected load inertia as low as possible while using the full range of servo speed. SureServo2 systems can go up to 6,000 rpm for the low inertia motors and up to 3,000 rpm for the medium inertia motors.

Example: A gearbox reduces the required torque by a factor of the gear ratio, and reduces the reflected load inertia by a factor of the gear ratio squared. A 10:1 gearbox reduces output speed to 1/10, increases output torque 10 times, and decreases reflected inertia to 1/100.

However, when investigating the effect of different speed reduction ratios DO NOT forget to include the added inertia of couplings, gearbox, or timing belt pulleys. These added inertias can be significant, and can negate any inertia reduction due to the speed reduction.

2. Low speed and high torque applications

If the application requires low speed and high torque then it is common to introduce a speed reducer so that the servo system can operate over more of the available speed range. This could also have the added benefit of reducing the servo motor torque requirement which could allow you to use a smaller and lower cost servo system. Additional benefits are also possible with reduction in reflected inertia, increased number of motor encoder counts at the load, and increased ability to reject load disturbances due to mechanical advantage of the speed reducer.

3. Space limitations and motor orientation

SureServo2 motors can be mounted in any orientation, but the shaft seal should not be immersed in oil (open-frame gearbox, etc.). Reducers can possibly allow the use of a smaller motor or allow the motor to be repositioned. For example, some reducers would allow for in-line, right angle, or parallel mounting of the motor.

For more information, refer to the website listed below.

Mechanical Transmission: Timing Belts and Pulleys Precision Gearboxes

Ordering guide instructions

The following four pages are your ordering guide for SureServo2 systems. Each system has a torque-speed curve included for reference. This is the fundamental information that you need to select the servo motor and matching drive for your application.

Each system needs:

- Motor
- Drive
- Motor Power Cable
- Motor Encoder Cable
- I/O connections (either CN1 cable + RTB breakout board, or an LTB20 breakout board that mounts on the drive)
- For brakemotors 4.5 kW and below, the brake wiring is included in the power cable. For brakemotors 5.5 kW and above, a separate brake cable is required.

A wide variety of optional accessories are also available, such as Ethernet cards, RS485 splitters/terminators, toroids, etc.

You can also use the SureServo2 selector tool on the AutomationDirect.com website to help you configure your system.



AC Servo System Configuration

SureServo2 series drives and motors part numbering system

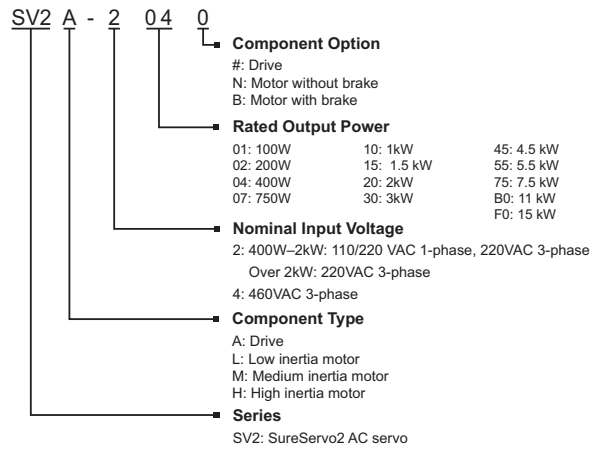

Here is what you will need to order a complete servo system:

- 1. Servo Drive**
- 2. Servo Motor**
- 3. Motor Power Cable**
- 4. Motor Encoder Cable**
- 5. I/O Interface**

NOTE: Unit can be programmed via keypad. Optional programming software (free download) and optional programming cable available.

NOTE: If you need a gear box for your configuration, you can do it easily online: <http://www.sureservo.com/gearbox/selector>





AC Servo System Configuration

Torque to SureServo2 System Quick Reference

230V System Torque			
System Rated Torque (N-m)	System Maximum Torque (N-m)	Suggested Servo Motor	Required Servo Drive
0.32	1.12	SV2L-201N or SV2L-201B	SV2A-2040
0.64	2.24	SV2L-202N or SV2L-202B	SV2A-2040
1.27	3.96	SV2L-204N or SV2L-204B	SV2A-2040
2.39	7.86	SV2L-207N or SV2L-207B	SV2A-2075
3.18	8.12	SV2L-210N or SV2L-210B	SV2A-2150
4.77	14.32	SV2M-210N or SV2M-210B	SV2A-2150
7.16	14.88	SV2M-215N or SV2M-215B	SV2A-2150
9.55	24.54	SV2M-220N or SV2M-220B	SV2A-2200
17.55	48.29	SV2M-230N or SV2M-230B	SV2A-2300
28.65	71.62	SV2H-245N or SV2H-245B	SV2A-2550
35.01	87.53	SV2H-255N or SV2H-255B	SV2A-2550
47.74	119.36	SV2H-275N or SV2H-275B	SV2A-2750
70	175	SV2H-2B0N or SV2H-2B0B	SV2A-2F00
95.4	224.0	SV2H-2F0N or SV2H-2F0B	SV2A-2F00

460V System Torque			
System Rated Torque (N-m)	System Maximum Torque (N-m)	Suggested Servo Motor	Required Servo Drive
1.27	4.45	SV2L-404N or SV2L-404B	SV2A-4040
2.24	7.58	SV2L-407N or SV2L-407B	SV2A-4075
3.18	9.54	SV2L-410N or SV2L-410B	SV2A-4150
4.77	14.32	SV2M-410N or SV2M-410B	SV2A-4150
7.16	18.1	SV2L-415N or SV2L-415B	SV2A-4150
9.55	28.65	SV2L-420N or SV2L-420B	SV2A-4200
19.1	49.38	SV2H-430N or SV2H-430B	SV2A-4300
28.65	64.61	SV2H-445N or SV2H-445B	SV2A-4550
35.01	73.48	SV2H-455N or SV2H-455B	SV2A-4550
47.74	93.71	SV2H-475N or SV2H-475B	SV2A-4750
70	175	SV2H-4B0N or SV2H-4B0B	SV2A-4F00
95.4	224.0	SV2H-4F0N or SV2H-4F0B	SV2A-4F00



AC Servo System Configuration

SureServo2 AC servo drive, motor, and cable combinations

	Input Voltage	Torque Chart	SureServo2 Motor	SureServo2 Drive	Power Cable*	Encoder Cable*
100W Low Inertia System	120V		SV2L-201N	SV2A-2040	SV2C-PA18-xxNN	SV2C-E122-xxNN
			SV2L-201B		SV2C-PA18-xxFN	SV2C-E122-xxFN
	230V		SV2L-201N		SV2C-PA18-xxNN	SV2C-E122-xxNN
			SV2L-201B		SV2C-PA18-xxFN	SV2C-E122-xxFN
200W Low Inertia System	120V		SV2L-202N	SV2A-2040	SV2C-PA18-xxNN	SV2C-E122-xxNN
			SV2L-202B		SV2C-PA18-xxFN	SV2C-E122-xxFN
	230V		SV2L-202N		SV2C-PA18-xxNN	SV2C-E122-xxNN
			SV2L-202B		SV2C-PA18-xxFN	SV2C-E122-xxFN

Note: "xx" in the cable part numbers represents cable length: SV2C-xxxx-10xx is a 10m cable.

The final two digits indicate flex rating and motor brake compatibility:

SV2C-xxxx-xxNN is a non-flex, non-brake motor cable

SV2C-xxxx-xxNB is a non-flex, brake motor cable

SV2C-xxxx-xxFN is a flex-rated, non-brake cable

SV2C-xxxx-xxFB is a flex-rated, brake motor cable

All Systems I/O

[SV2-CN1-CBL50xxx + SV2-CN1-RTB50](#)

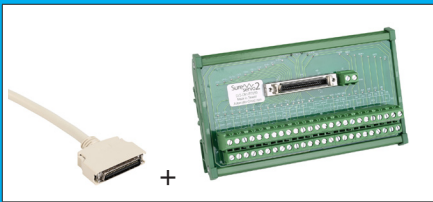

OR

[SV2-CN1-LTB20](#)





SureServo2 System Selector
Online



AC Servo System Configuration

SureServo2 AC servo drive, motor, and cable combinations, *continued*

Input Voltage	Torque Chart	SureServo2 Motor	SureServo2 Drive	Power Cable*	Encoder Cable*
120V		SV2L-204N	SV2A-2040	SV2C-PA18-xxNN	SV2C-E122-xxNN
				SV2C-PA18-xxFN	SV2C-E122-xxFN
		SV2L-204B		SV2C-PB18-xxNB	SV2C-E122-xxNN
				SV2C-PB18-xxFB	SV2C-E122-xxFN
230V		SV2L-204N	SV2A-2040	SV2C-PA18-xxNN	SV2C-E122-xxNN
				SV2C-PA18-xxFN	SV2C-E122-xxFN
		SV2L-204B		SV2C-PB18-xxNB	SV2C-E122-xxNN
				SV2C-PB18-xxFB	SV2C-E122-xxFN
460V		SV2L-404N	SV2A-4040	SV2C-PA18-xxNN	SV2C-E122-xxNN
				SV2C-PA18-xxFN	SV2C-E122-xxFN
		SV2L-404B		SV2C-PB18-xxNB	SV2C-E122-xxNN
				SV2C-PB18-xxFB	SV2C-E122-xxFN

400W Low Inertia System

Note: "xx" in the cable part numbers represents cable length: SV2C-xxxx-10xx is a 10m cable.
 The final two digits indicate flex rating and motor brake compatibility:
 SV2C-xxxx-xxNN is a non-flex, non-brake motor cable SV2C-xxxx-xxFN is a flex-rated, non-brake cable
 SV2C-xxxx-xxNB is a non-flex, brake motor cable SV2C-xxxx-xxFB is a flex-rated, brake motor cable

All Systems I/O

SV2-CN1-CBL50xxx + SV2-CN1-RTB50

OR

SV2-CN1-LTB20



SureServo2 System Selector
Online



AC Servo System Configuration

SureServo2 AC servo drive, motor, and cable combinations, *continued*

750W Low Inertia System	Input Voltage	Torque Chart	SureServo2 Motor	SureServo2 Drive	Power Cable*	Encoder Cable*
	120V		SV2L-207N	SV2A-2075	SV2C-PA18-xxNN	SV2C-E122-xxNN
			SV2L-207B		SV2C-PA18-xxFN	SV2C-E122-xxFN
	230V		SV2L-207N	SV2A-2075	SV2C-PA18-xxNN	SV2C-E122-xxNN
SV2L-207B			SV2C-PA18-xxFN		SV2C-E122-xxFN	
460V		SV2L-407N	SV2A-4075	SV2C-PA18-xxNN	SV2C-E122-xxNN	
		SV2L-407B		SV2C-PA18-xxFN	SV2C-E122-xxFN	
				SV2C-PB18-xxNB	SV2C-E122-xxNN	
				SV2C-PB18-xxFB	SV2C-E122-xxFN	

Note: "xx" in the cable part numbers represents cable length: SV2C-xxxx-10xx is a 10m cable.
 The final two digits indicate flex rating and motor brake compatibility:
 SV2C-xxxx-xxNN is a non-flex, non-brake motor cable SV2C-xxxx-xxFN is a flex-rated, non-brake cable
 SV2C-xxxx-xxNB is a non-flex, brake motor cable SV2C-xxxx-xxFB is a flex-rated, brake motor cable

All Systems I/O

SV2-CN1-CBL50xxx + SV2-CN1-RTB50

OR

SV2-CN1-LTB20



[SureServo2 System Selector Online](#)



AC Servo System Configuration

SureServo2 AC servo drive, motor, and cable combinations, *continued*

Input Voltage	Torque Chart	SureServo2 Motor	SureServo2 Drive	Power Cable*	Encoder Cable*
120V		SV2L-210N	SV2A-2150	SV2C-PC16-xxNN	SV2C-E222-xxNN
				SV2C-PC16-xxFN	SV2C-E222-xxFN
		SV2L-210B		SV2C-PC16-xxNB	SV2C-E222-xxNN
				SV2C-PC16-xxFB	SV2C-E222-xxFN
230V		SV2L-210N	SV2A-2150	SV2C-PC16-xxNN	SV2C-E222-xxNN
				SV2C-PC16-xxFN	SV2C-E222-xxFN
		SV2L-210B		SV2C-PC16-xxNB	SV2C-E222-xxNN
				SV2C-PC16-xxFB	SV2C-E222-xxFN
460V		SV2L-410N	SV2A-4150	SV2C-PC16-xxNN	SV2C-E222-xxNN
				SV2C-PC16-xxFN	SV2C-E222-xxFN
		SV2L-410B		SV2C-PC16-xxNB	SV2C-E222-xxNN
				SV2C-PC16-xxFB	SV2C-E222-xxFN

1.0 kW Low Inertia System

Note: "xx" in the cable part numbers represents cable length: SV2C-xxxx-10xx is a 10m cable.
 The final two digits indicate flex rating and motor brake compatibility:
 SV2C-xxxx-xxNN is a non-flex, non-brake motor cable SV2C-xxxx-xxFN is a flex-rated, non-brake cable
 SV2C-xxxx-xxNB is a non-flex, brake motor cable SV2C-xxxx-xxFB is a flex-rated, brake motor cable

All Systems I/O

SV2-CN1-CBL50xxx + SV2-CN1-RTB50

OR

SV2-CN1-LTB20



SureServo2 System Selector
Online



AC Servo System Configuration

SureServo2 AC servo drive, motor, and cable combinations, *continued*

Input Voltage	Torque Chart	SureServo2 Motor	SureServo2 Drive	Power Cable*	Encoder Cable*	
120V		SV2M-210N	SV2A-2150	SV2C-PC12-xxNN	SV2C-E222-xxNN	
					SV2C-PC12-xxFN	SV2C-E222-xxFN
		SV2M-210B			SV2C-PC12-xxNB	SV2C-E222-xxNN
					SV2C-PC12-xxFB	SV2C-E222-xxFN
230V		SV2M-210N	SV2A-2150	SV2C-PC12-xxNN	SV2C-E222-xxNN	
					SV2C-PC12-xxFN	SV2C-E222-xxFN
		SV2M-210B			SV2C-PC12-xxNB	SV2C-E222-xxNN
					SV2C-PC12-xxFB	SV2C-E222-xxFN
460V		SV2M-410N	SV2A-4150	SV2C-PC16-xxNN	SV2C-E222-xxNN	
					SV2C-PC16-xxFN	SV2C-E222-xxFN
		SV2M-410B			SV2C-PC16-xxNB	SV2C-E222-xxNN
					SV2C-PC16-xxFB	SV2C-E222-xxFN

Note: "xx" in the cable part numbers represents cable length: SV2C-xxxx-10xx is a 10m cable.
 The final two digits indicate flex rating and motor brake compatibility:
 SV2C-xxxx-xxNN is a non-flex, non-brake motor cable SV2C-xxxx-xxFN is a flex-rated, non-brake cable
 SV2C-xxxx-xxNB is a non-flex, brake motor cable SV2C-xxxx-xxFB is a flex-rated, brake motor cable

All Systems I/O

SV2-CN1-CBL50xxx + SV2-CN1-RTB50

OR

SV2-CN1-LTB20



[SureServo2 System Selector Online](#)



AC Servo System Configuration

SureServo2 AC servo drive, motor, and cable combinations, *continued*

	Input Voltage	Torque Chart	SureServo2 Motor	SureServo2 Drive	Power Cable*	Encoder Cable*	
1.5 kW Medium Inertia System	120V		SV2M-215N	SV2A-2150	SV2C-PC12-xxNN	SV2C-E222-xxNN	
			SV2M-215B		SV2C-PC12-xxFN	SV2C-E222-xxFN	
	230V		SV2M-215N		SV2C-PC12-xxNN	SV2C-E222-xxNN	
			SV2M-215B		SV2C-PC12-xxNB	SV2C-E222-xxNN	
1.5 kW Low Inertia System	460V		SV2L-415N	SV2A-4150	SV2C-PC16-xxNN	SV2C-E222-xxNN	
			SV2L-415B		SV2C-PC16-xxFN	SV2C-E222-xxFN	
						SV2C-PC16-xxNB	SV2C-E222-xxNN
						SV2C-PC16-xxFB	SV2C-E222-xxFN

Note: "xx" in the cable part numbers represents cable length: SV2C-xxxx-10xx is a 10m cable.
 The final two digits indicate flex rating and motor brake compatibility:
 SV2C-xxxx-xxNN is a non-flex, non-brake motor cable SV2C-xxxx-xxFN is a flex-rated, non-brake cable
 SV2C-xxxx-xxNB is a non-flex, brake motor cable SV2C-xxxx-xxFB is a flex-rated, brake motor cable

All Systems I/O

SV2-CN1-CBL50xxx + SV2-CN1-RTB50

OR

SV2-CN1-LTB20



[SureServo2 System Selector Online](#)



AC Servo System Configuration

SureServo2 AC servo drive, motor, and cable combinations, *continued*

	Input Voltage	Torque Chart	SureServo2 Motor	SureServo2 Drive	Power Cable*	Encoder Cable*
2.0 kW Medium Inertia System	120V		SV2M-220N	SV2A-2200	SV2C-PD12-xxNN	SV2C-E222-xxNN
					SV2C-PD12-xxFN	SV2C-E222-xxFN
			SV2M-220B		SV2C-PD12-xxNB	SV2C-E222-xxNN
					SV2C-PD12-xxFB	SV2C-E222-xxFN
2.0 kW Medium Inertia System	230V		SV2M-220N	SV2A-2200	SV2C-PD12-xxNN	SV2C-E222-xxNN
					SV2C-PD12-xxFN	SV2C-E222-xxFN
			SV2M-220B		SV2C-PD12-xxNB	SV2C-E222-xxNN
					SV2C-PD12-xxFB	SV2C-E222-xxFN
2.0 kW Low Inertia System	460V		SV2L-420N	SV2A-4200	SV2C-PC16-xxNN	SV2C-E222-xxNN
					SV2C-PC16-xxFN	SV2C-E222-xxFN
			SV2L-420B		SV2C-PC16-xxNB	SV2C-E222-xxNN
					SV2C-PC16-xxFB	SV2C-E222-xxFN

Note: "xx" in the cable part numbers represents cable length: SV2C-xxxx-10xx is a 10m cable.

The final two digits indicate flex rating and motor brake compatibility:

SV2C-xxxx-xxNN is a non-flex, non-brake motor cable

SV2C-xxxx-xxNB is a non-flex, brake motor cable

SV2C-xxxx-xxFN is a flex-rated, non-brake cable

SV2C-xxxx-xxFB is a flex-rated, brake motor cable

All Systems I/O

SV2-CN1-CBL50xxx + SV2-CN1-RTB50

OR

SV2-CN1-LTB20



[SureServo2 System Selector Online](#)



AC Servo System Configuration

SureServo2 AC servo drive, motor, and cable combinations, *continued*

Input Voltage	Torque Chart	SureServo2 Motor	SureServo2 Drive	Power Cable*	Encoder Cable*
230V		SV2M-230N	SV2A-2300	SV2C-PD12-xxNN	SV2C-E222-xxNN
				SV2C-PD12-xxFN	SV2C-E222-xxFN
		SV2M-230B		SV2C-PD12-xxNB	SV2C-E222-xxNN
				SV2C-PD12-xxFB	SV2C-E222-xxFN
460V		SV2H-430N	SV2A-4300	SV2C-PD12-xxNN	SV2C-E222-xxNN
				SV2C-PD12-xxFN	SV2C-E222-xxFN
		SV2H-430B		SV2C-PD12-xxNB	SV2C-E222-xxNN
				SV2C-PD12-xxFB	SV2C-E222-xxFN

Note: "xx" in the cable part numbers represents cable length: SV2C-xxxx-10xx is a 10m cable.
 The final two digits indicate flex rating and motor brake compatibility:
 SV2C-xxxx-xxNN is a non-flex, non-brake motor cable SV2C-xxxx-xxFN is a flex-rated, non-brake cable
 SV2C-xxxx-xxNB is a non-flex, brake motor cable SV2C-xxxx-xxFB is a flex-rated, brake motor cable

All Systems I/O

SV2-CN1-CBL50xxx + SV2-CN1-RTB50

OR

SV2-CN1-LTB20



[SureServo2 System Selector Online](#)



AC Servo System Configuration

SureServo2 AC servo drive, motor, and cable combinations, *continued*

Input Voltage	Torque Chart	SureServo2 Motor	SureServo2 Drive	Power Cable*	Encoder Cable*
230V		SV2H-245N	SV2A-2550	SV2C-PD08-xxNN	SV2C-E222-xxNN
				SV2C-PD08-xxFN	SV2C-E222-xxFN
		SV2H-245B		SV2C-PD08-xxNB	SV2C-E222-xxNN
				SV2C-PD08-xxFB	SV2C-E222-xxFN
460V		SV2H-445N	SV2A-4550	SV2C-PD08-xxNN	SV2C-E222-xxNN
				SV2C-PD08-xxFN	SV2C-E222-xxFN
		SV2H-445B		SV2C-PD08-xxNB	SV2C-E222-xxNN
				SV2C-PD08-xxFB	SV2C-E222-xxFN

Note: "xx" in the cable part numbers represents cable length: SV2C-xxxx-10xx is a 10m cable.
 The final two digits indicate flex rating and motor brake compatibility:
 SV2C-xxxx-xxNN is a non-flex, non-brake motor cable SV2C-xxxx-xxFN is a flex-rated, non-brake cable
 SV2C-xxxx-xxNB is a non-flex, brake motor cable SV2C-xxxx-xxFB is a flex-rated, brake motor cable

All Systems I/O

SV2-CN1-CBL50xxx + SV2-CN1-RTB50

OR

SV2-CN1-LTB20



[SureServo2 System Selector Online](#)



AC Servo System Configuration

SureServo2 AC servo drive, motor, and cable combinations, *continued*

Input Voltage	Torque Chart	SureServo2 Motor	SureServo2 Drive	Power Cable*	Encoder Cable*
230V		SV2H-255N	SV2A-2550	SV2C-PF06-xxNN	SV2C-E222-xxNN
				SV2C-PF06-xxFN	SV2C-E222-xxFN
		SV2H-255B		SV2C-PF06-xxNN and SV2C-B120-xxxx	SV2C-E222-xxNN
				SV2C-PF06-xxFN and SV2C-B120-xxxx	SV2C-E222-xxFN
460V		SV2H-455N	SV2A-4550	SV2C-PD08-xxNN	SV2C-E222-xxNN
				SV2C-PD08-xxFN	SV2C-E222-xxFN
		SV2H-455B		SV2C-PD08-xxNN	SV2C-E222-xxNN
				SV2C-PD08-xxFN	SV2C-E222-xxFN

Note: "xx" in the cable part numbers represents cable length: SV2C-xxxx-10xx is a 10m cable.
 The final two digits indicate flex rating and motor brake compatibility:
 SV2C-xxxx-xxNN is a non-flex, non-brake motor cable SV2C-xxxx-xxFN is a flex-rated, non-brake cable
 SV2C-xxxx-xxNB is a non-flex, brake motor cable SV2C-xxxx-xxFB is a flex-rated, brake motor cable

All Systems I/O

SV2-CN1-CBL50xxx + SV2-CN1-RTB50

OR

SV2-CN1-LTB20



[SureServo2 System Selector Online](#)



AC Servo System Configuration

SureServo2 AC servo drive, motor, and cable combinations, *continued*

Input Voltage	Torque Chart	SureServo2 Motor	SureServo2 Drive	Power Cable*	Encoder Cable*
230V		SV2H-275N	SV2A-2750	SV2C-PF06-xxNN	SV2C-E222-xxNN
				SV2C-PF06-xxFN	SV2C-E222-xxFN
		SV2H-275B		SV2C-PF06-xxNN and SV2C-B120-xxxx	SV2C-E222-xxNN
				SV2C-PF06-xxFN and SV2C-B120-xxxx	SV2C-E222-xxFN
460V		SV2H-475N	SV2A-4750	SV2C-PD08-xxNN	SV2C-E222-xxNN
				SV2C-PD08-xxFN	SV2C-E222-xxFN
		SV2H-475B		SV2C-PD08-xxNN	SV2C-E222-xxNN
				SV2C-PD08-xxFN	SV2C-E222-xxFN

Note: "xx" in the cable part numbers represents cable length: SV2C-xxxx-10xx is a 10m cable.
 The final two digits indicate flex rating and motor brake compatibility:
 SV2C-xxxx-xxNN is a non-flex, non-brake motor cable SV2C-xxxx-xxFN is a flex-rated, non-brake cable
 SV2C-xxxx-xxNB is a non-flex, brake motor cable SV2C-xxxx-xxFB is a flex-rated, brake motor cable

All Systems I/O

SV2-CN1-CBL50xxx + SV2-CN1-RTB50

OR

SV2-CN1-LTB20



[SureServo2 System Selector Online](#)



AC Servo System Configuration

SureServo2 AC servo drive, motor, and cable combinations, *continued*

Input Voltage	Torque Chart	SureServo2 Motor	SureServo2 Drive	Power Cable*	Encoder Cable*
230V		SV2H-2B0N	SV2A-2F00	SV2C-PF06-xxNN	SV2C-E222-xxNN
				SV2C-PF06-xxFN	SV2C-E222-xxFN
		SV2H-2B0B		SV2C-PF06-xxNN and SV2C-B120-xxNB	SV2C-E222-xxNN
				SV2C-PF06-xxFN and SV2C-B120-xxFB	SV2C-E222-xxFN
460V		SV2H-4B0N	SV2A-4F00	SV2C-PF08-xxNN	SV2C-E222-xxNN
				SV2C-PF08-xxFN	SV2C-E222-xxFN
		SV2H-4B0B		SV2C-PF08-xxNN and SV2C-B120-xxNB	SV2C-E222-xxNN
				SV2C-PF08-xxFN and SV2C-B120-xxFB	SV2C-E222-xxFN

Note: "xx" in the cable part numbers represents cable length: SV2C-xxxx-10xx is a 10m cable.
 The final two digits indicate flex rating and motor brake compatibility:
 SV2C-xxxx-xxNN is a non-flex, non-brake motor cable SV2C-xxxx-xxFN is a flex-rated, non-brake cable
 SV2C-xxxx-xxNB is a non-flex, brake motor cable SV2C-xxxx-xxFB is a flex-rated, brake motor cable

All Systems I/O

SV2-CN1-CBL50xxx + SV2-CN1-RTB50

OR

SV2-CN1-LTB20



SureServo2 System Selector
[Online](#)

SureServo2 AC servo drive, motor, and cable combinations, *continued*

Input Voltage	Torque Chart	SureServo2 Motor	SureServo2 Drive	Power Cable*	Encoder Cable*
230V		SV2H-2F0N	SV2A-2F00	SV2C-PF04-xxNN	SV2C-E222-xxNN
				SV2C-PF04-xxFN	SV2C-E222-xxFN
		SV2H-2F0B		SV2C-PF04-xxNN and SV2C-B120-xxNB	SV2C-E222-xxNN
				SV2C-PF04-xxFB and SV2C-B120-xxFB	SV2C-E222-xxFN
460V		SV2H-4F0N	SV2A-4F00	SV2C-PF08-xxNN	SV2C-E222-xxNN
				SV2C-PF08-xxFN	SV2C-E222-xxFN
		SV2H-4F0B		SV2C-PF08-xxNN and SV2C-B120-xxNB	SV2C-E222-xxNN
				SV2C-PF08-xxFN and SV2C-B120-xxFB	SV2C-E222-xxFN

Note: "xx" in the cable part numbers represents cable length: SV2C-xxxx-10xx is a 10m cable.
 The final two digits indicate flex rating and motor brake compatibility:
 SV2C-xxxx-xxNN is a non-flex, non-brake motor cable SV2C-xxxx-xxFN is a flex-rated, non-brake cable
 SV2C-xxxx-xxNB is a non-flex, brake motor cable SV2C-xxxx-xxFB is a flex-rated, brake motor cable

All Systems I/O

SV2-CN1-CBL50xxx + SV2-CN1-RTB50

OR

SV2-CN1-LTB20



[SureServo2 System Selector Online](#)



AC Servo System Software



SureServo2 Pro configuration software

SureServo2 Pro is an optional free downloadable configuration software package for the SureServo2 drives. With SureServo2 Pro installed, a PC may be directly connected to the servo drive via a USB programming cable (part# SV2-PGM-USB15 or SV2-PGM-USB30).

Features

- Easy-to-use Parameter Wizards to guide you through the most common setup functions.
- Digital IO/Jog Control allows the user to operate the servo system from the PC. This is a great aid during start-up to allow the servo to perform some basic motion and to check the I/O.
- Parameter Editor - The complete setup for all the drive parameters
- Tune and check the servo response live using the scope feature.
- Upload and download the drive setup. Save the drive setup as a file for backup or future use.
- Edit the drive setup
- View all drive faults
- View drive variable trends in real time
- Create a custom EtherNet/IP EDS file for data transfer to a PLC using pull-down menus
- Motion Programming ability - the PR Window lets you configure the 99 "Paths" that store the motion and sequencing commands in the drive

Parameter editor

The SureServo2 Pro configuration tool logically organizes all servo drive parameters for viewing and editing using the Parameter Editor screen. Each parameter has a factory default that usually allows the servo to run "out-of-the-box".

The parameters can be easily changed with available setting ranges displayed. Tuning modes and parameters can also be changed using SureServo2 Pro. After the parameters have been defined, the complete setup can be stored and archived. Drive configurations can be uploaded, edited, saved, and downloaded as often as necessary.

SS2 Pro software even has an "Offline Mode" so you can configure your drive and program your motion without having to be connected to the drive.

Parameter Editor Example Screen

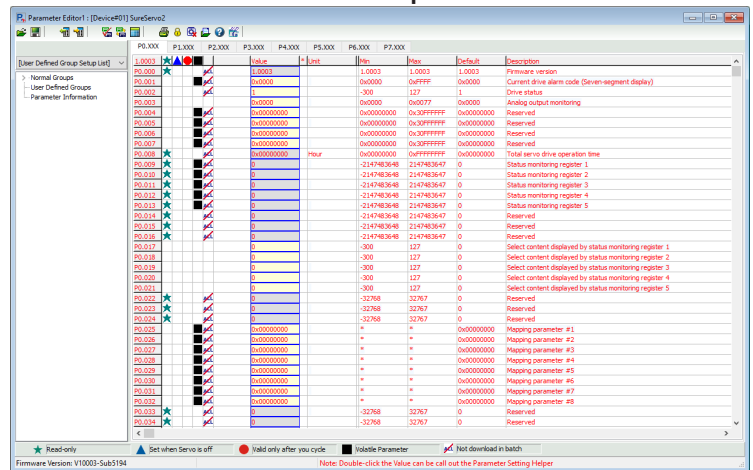

USB Programming Cables

Part Number	Price	Description	Length	Drawing	Compatible Drives
SV2-PGM-USB15	\$32.00	Programming cable, USB A to miniB-USB	1.5 m	PDF	All SureServo2 drives
SV2-PGM-USB30	\$34.50		3m	PDF	



SV2-PGM-USB15



AC Servo System Software

SureServo2 Pro configuration software - (continued)

General Setting Example Screen

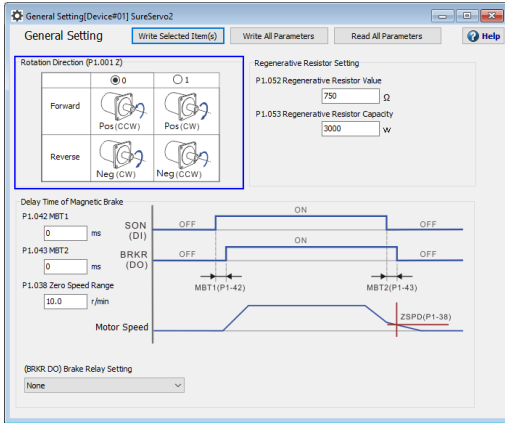

Digital IO/Jog Control screen

The Digital IO/Jog Control screen allows the user to operate the servo system from the PC. This is a great aid during start-up to allow the servo to perform some basic motion and to check the I/O.

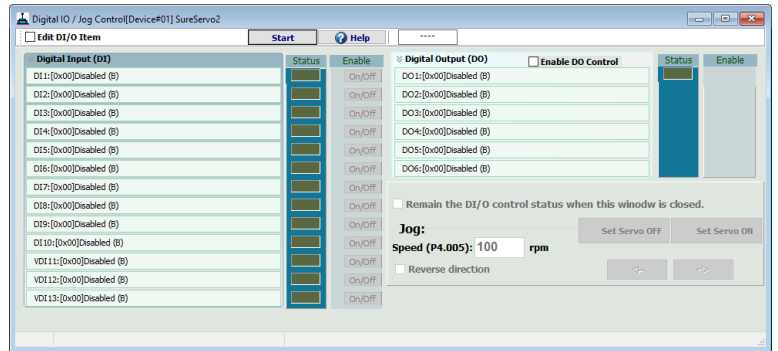

Alarm Information Example Screen

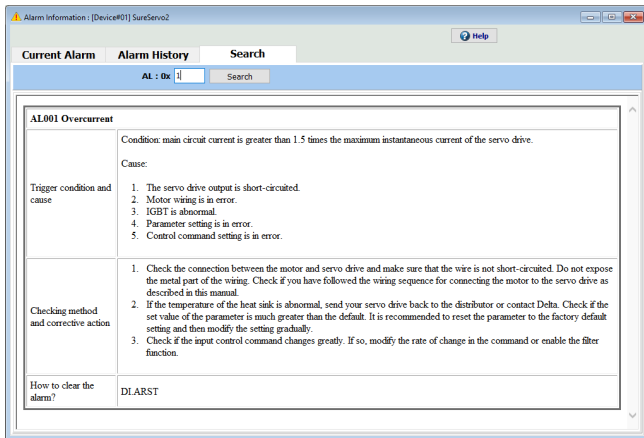

Scope

SureServo2 Pro includes a powerful scope function that allows the user to have as many as eight channels of data displayed simultaneously. Each channel has a drop-down table to select the data to be displayed. The scope has the ability to save traces to a file and load those traces for offline review/analysis. This function is a valuable tool for tuning SureServo2 drives.

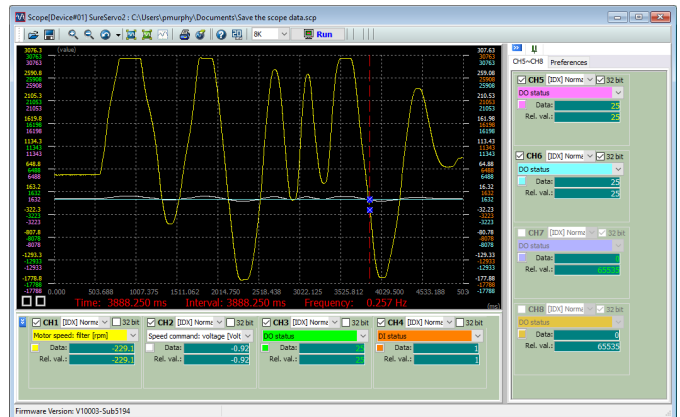

PR Mode Setting Example Screen

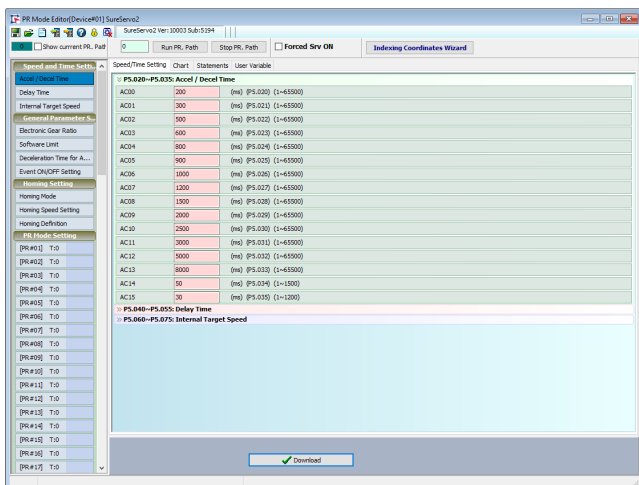

Servo drive overview

Charge

LED is lit when DC bus is energized (may take several seconds for power to dissipate after incoming power is removed)

LED Display

The LED display has 5 full digits and is used to indicate servo status and alarms

Safe Torque Off (STO) Connector Port

Keypad

Five Function keys:

- MODE: Press to change mode
- SHIFT: Press to change parameter group or move cursor left
- UP: Press to increase values
- DOWN: Press to decrease values
- SET: Press to enter value

Control Power Terminal

220VAC drives: control power = 120 or 220 VAC single phase.

460VAC drives: control power = 24VDC

Main Power Terminal

- 1 phase 110VAC: 100W-2kW
- 1 phase 220VAC: 100W-2kW
- 3 phase 220VAC: 100W-15kW
- 3 phase 460VAC: 400W-15kW

Regenerative Resistor Terminal

1. When the internal regenerative resistor is used, the P3 and D terminal are connected together while the P3 and C connection is left open.
2. When an external regenerative resistor is used, it is connected across the P3 and C terminals while the P3 and D connection is left open. See the user manual for recommended resistance and power requirements for each system.

Motor Output Terminal

The servo motor power cable is connected to U, V and W. Use our factory made and tested cables available in 3, 5, 10, or 20 meter lengths for easy and trouble free connection.

Ground Terminals



High Density DB15 Connector

CN5: Auxiliary/Secondary Encoder input. Used for applications requiring Full Closed Loop, Linear Measurement, etc.

USB Connector

Used to connect a PC for configuration with SureServo2 Pro software

Serial Communication Interface

RJ45 connectors for RS485 Modbus communication between drives and controllers. Modbus RTU/ASCII protocol. Use our factory-made cables for easy connection to the PC or the host controller.

I/O Interface

50-pin connector for interfacing the host controller and other types of I/O signals.

- CBL50 + RTB50 = Cable and remote DIN-rail mount module. All I/O pins available.
- LTB20 = Mounted and wired directly at CN1. Most commonly used pins available.
- Command inputs:
 - Pulse and Direction
 - Encoder Follower
 - Analog Velocity/Torque
- (10) Digital Inputs
- (6) Digital Outputs
- (2) Analog Monitors
- Encoder Output (scalable)

A+, A-, B+, B-, Z+, Z-

Encoder Interface

Connector for interfacing the servo motor encoder. Use our factory-made and tested cables available in 3, 5, 10, or 20 meter lengths for easy and trouble free connection.

SureServo2 systems run "out-of-the-box"... but may be reconfigured for many applications!

The SureServo2 drives are fully digital and include over 400 programmable parameters. For convenience, the parameters are grouped into five categories:

1. Monitor parameters
2. Basic parameters
3. Extended parameters
4. Communication parameters
5. Diagnostic and analog parameters
6. Motion control parameters
7. PATH definition parameters

All parameters have commonly used default values which allow you to operate the SureServo2 system "out-of-the-box". However, the programmability and large variety of parameters make the SureServo2 systems suitable for a very broad range of applications, including almost all types of general purpose industrial machinery such as assembly, test, packaging, machine tool, and robotics.

The SureServo2 Pro configuration software has Parameter Wizards to quickly and easily guide you through the most common setup routines.



AC Servo Drive Specifications

230V Servo drive specifications

SureServo2 230V Drive Specifications									
Model	SV2A-2040	SV2A-2075	SV2A-2150	SV2A-2200	SV2A-2300	SV2A-2550	SV2A-2750	SV2A-2F00	
Price	\$383.00	\$477.00	\$509.00	\$598.00	\$660.00	\$836.00	\$977.00	\$1,277.00	
Drawing	PDF	PDF	PDF	PDF	PDF	PDF	PDF	PDF	
Power	Power Rating	400W	750W	1.5 kW	2kW	3kW	5.5 kW	7.5 kW	15kW
	Input Voltage	Single-phase 100–120 VAC, -15% to +10% Single-phase 200–230 VAC, -15% to +10% Three-phase 200–230 VAC, -15% to +10%				Three-phase 200–230 VAC, -15% to +10%			
	Input Current 200–230 VAC 3-phase [Amps] rms	2.76	5.09	8.09	11.36	14.52	27.06	37.33	69.95
	Input Current 100–120 VAC 1-phase [Amps] rms	3.98	7.73	12.56	18.03	–	–	–	–
	Input Current 200–230 VAC 1-phase [Amps] rms	4.69	8.71	14.82	20.83	–	–	–	–
	Continuous Output Current [Amps] rms	2.60	5.10	8.33	13.40	17.92	41.33	49.04	78
	Max. Instantaneous Output Current [Amps] rms	8.56	15.43	20.16	40.57	55.93	91.44	127.46	162.04
	Main Circuit Inrush Current [Amps]	1.44	1.40	1.44	4.64	4.42	9.55	28.68	32.0
	Control Circuit Inrush Current [Amps]	37.0	37.40	39.80	32.40	36.40	32.80	40.0	37.0
Cooling Method	Air Conv. Cooling	Fan Cooling							
Encoder Resolution	24-bit (16777216 p/rev)								
Main Circuit Control	SVPWM control								
Control Mode	Manual / Auto								
Regenerative Resistor	Built-in (external options also available)					External (optional)			
Position Control Mode	Pulse Type	Pulse + Direction, CCW pulse + CW pulse, AB Quadrature							
	Max. Input Pulse Frequency	Pulse + Direction: 4 Mpps; CCW pulse + CW pulse: 4 Mpps; AB Quadrature: single-phase 4 Mpps; Open collector: 200 Kpps							
	Command Source	External pulse / Internal registers							
	Smoothing Method	Low-pass and P-curve filter							
	Torque Limit	Parameter settings							
	Feed Forward Compensation	Parameter settings							



AC Servo Drive Specifications

230V Servo drive specifications (continued)

SureServo2 230V Drive Specifications Continued									
Model		SV2A-2040	SV2A-2075	SV2A-2150	SV2A-2200	SV2A-2300	SV2A-2550	SV2A-2750	SV2A-2F00
Speed Control Mode	Analog Command Input	Voltage Range	±10VDC						
		Resolution	15-bit						
		Input Impedance	1MΩ						
		Time Constant	25μs						
	Speed Control Range1	1 : 6000							
	Command Source	External analog command / Internal registers							
	Smoothing Method	Low-pass and S-curve filter							
	Torque Limit	Parameter settings / Analog input							
	Bandwidth	Maximum 3.1 kHz (closed-loop)							
	Speed Calibration Ratio2	±0.01% at 0% to 100% load fluctuation ±0.01% at ±10% power fluctuation ±0.01% at 0°C to 50°C ambient temperature fluctuation							
Torque Control Mode	Analog Command Input	Voltage Range	±10VDC						
		Input Impedance	1MΩ						
		Time Constant	25μs						
	Command Source	External analog command / Internal registers							
	Smoothing Method	Low-pass filter							
	Speed Limit	Parameter settings / Analog input							
Analog Monitor Output		Monitor signal can be set by parameters (voltage output range: ±8V); resolution:10-bit							
Digital Input/Output	Input	Servo on, Fault reset, Gain switch, Pulse clear, Zero speed clamping, Command input reverse control, Internal position command trigger, Torque limit, Speed limit, Internal position command selection, Motor stop, Speed command selection, Speed / position mode switching, Speed / torque mode switching, Torque / position mode switching, PT / PR command switching, motor override, Forward / reverse limit, Original point, Forward / reverse operation torque limit, Homing activated, E-Cam engage, Forward / reverse JOG input, Event trigger, E-Gear N selection, Pulse input prohibition							
	Output	A, B, Z line driver output Servo ready, Servo on, Zero speed detection, Target speed reached, Target position reached, Torque limiting, Servo alarm, Magnetic brake control, Homing completed, Early warning for overload, Servo warning, Position command overflows, Software limit (reverse direction), Software limit (forward direction), Internal position command completed, Capture procedure completed, Servo procedure completed, Master position area of E-Cam.							

1 - Within the rated load, the speed ratio is: the minimum speed (smooth operation) / rated speed.

2 - Within the rated speed, the speed calibration ratio is: (rotational speed with no load - rotational speed with full load) / rated speed.



AC Servo Drive Specifications

230V Servo drive specifications (continued)

SureServo2 230V Drive Specifications Continued								
Model	<u>SV2A-2040</u>	<u>SV2A-2075</u>	<u>SV2A-2150</u>	<u>SV2A-2200</u>	<u>SV2A-2300</u>	<u>SV2A-2550</u>	<u>SV2A-2750</u>	<u>SV2A-2F00</u>
Protection Function	STO (Category 3 / SIL 2), Overcurrent, Overvoltage, Undervoltage, Overheat, Regeneration error, Overload, Excessive speed deviation, Excessive position deviation, Encoder error, Adjustment error, Emergency stop, Forward / reverse limit error, Excessive deviation of full-closed loop control, Serial communication error, RST leak phase, Serial communication timeout, Short-circuit protection for terminals U, V, W and CN1, CN2, CN3							
Communication Interface	RS-485 / Modbus RTU / USB / Optional EtherNet/IP or Modbus TCP							
Weight [kg (lb)]	0.92 (2.03)	1.3 (2.87)	1.3 (2.87)	2.7 (5.95)	2.7 (5.95)	4.9 (10.8)	7.2 (15.9)	13 (29)
Environment	Installation Site	Indoors (avoid direct sunlight), no corrosive vapor (avoid fumes, flammable gases, and dust)						
	Altitude	Altitude 1000m or lower above sea level						
	Atmospheric Pressure	86kPa - 106kPa						
	Operating Temperature	0°C to 55°C (If operating temperature is above 45°C, forced cooling is required)						
	Storage Temperature	-20°C to 65°C						
	Humidity	Under 0 - 90% RH (non-condensing)						
	Vibration	9.80665 m/s ² (1 G) less than 20 Hz, 5.88 m/s ² (0.6 G) 20 to 50 Hz						
	IP Rating	IP20						
Power System	TN system3,4							
Approvals	IEC/EN 61800-5-1, UL 508C, TUV (for STO), CE							

3 - TN system: the neutral point of the power system connects directly to the ground. The exposed metal components connect to the ground through the protective ground conductor.

4 - Use a single-phase three-wire power system for the single-phase power model.



AC Servo Drive Specifications

460V Servo drive specifications

SureServo2 460V Drive Specifications									
Model	SV2A-4040	SV2A-4075	SV2A-4150	SV2A-4200	SV2A-4300	SV2A-4550	SV2A-4750	SV2A-4F00	
Price	\$460.00	\$485.00	\$665.00	\$648.00	\$730.00	\$836.00	\$1,050.00	\$1,363.00	
Drawing	PDF	PDF	PDF	PDF	PDF	PDF	PDF	PDF	
Power	Power Rating	400W	750W	1.5 kW	2kW	3kW	5.5 kW	15kW	
	Input Voltage	Three-phase 380–480 VAC, $\pm 10\%$							
	Input Current 380–480 VAC 3-phase [Amps] rms	1.49	2.31	4.98	6.29	9.92	16.83	23.06	36.65
	Continuous Output Current [Amps] rms	1.6	2.91	6.05	6.7	12.6	23.6	28.7	40.5
	Max. Instantaneous Output Current [Amps] rms	5.4	9.7	13.94	21.35	30.46	47.5	57.69	95.3
	Control Power Input Current	1.17	1.17	1.17	1.35	1.63	1.91	1.91	4.26
	Main Circuit Inrush Current [Amps]	5.6	5.6	5.6	12.5	12.5	12.5	12.5	12.5
	Control Circuit Inrush Current [Amps]	5	5	5	4.8	4.8	5.5	5.5	6
Control Circuit Voltage	24VDC								
Cooling Method	Fan cooling								
Encoder Resolution	24-bit (16777216 p/rev)								
Main Circuit Control	SVPWM control								
Control Mode	Manual/Auto								
Regenerative Resistor	Built-in (external options also available)			External (optional)					
Position Control Mode	Pulse Type	Pulse + Direction, CCW pulse + CW pulse, A phase + B phase							
	Max. Input Pulse Frequency	Pulse + Direction: 4 Mpps; CCW pulse + CW pulse: 4 Mpps; A phase + B phase: single-phase 4 Mpps; Open collector: 200 Kpps							
	Command Source	External pulse / Internal registers							
	Smoothing Method	Low-pass, moving-averaging, and S-curve filter							
	E-Gear Ratio	N/M times, limited to $(1/4 < N/M < 262144)$ N: 1–536870911 / M: 1–2147483647							
	Torque Limit	Parameter settings							
	Feed Forward Compensation	Parameter settings							



AC Servo Drive Specifications

460V Servo drive specifications (continued)

SureServo2 460V Drive Specifications Continued									
Model		SV2A-4040	SV2A-4075	SV2A-4150	SV2A-4200	SV2A-4300	SV2A-4550	SV2A-4750	SV2A-4F00
Speed Control Mode	Analog Command Input	Voltage Range	±10VDC						
		Resolution	12-bit						
		Input Impedance	1MΩ						
		Time Constant	25μs						
	Speed Control Range ¹	1 : 6000							
	Command Source	External analog command / Internal registers							
	Smoothing Method	Low-pass and S-curve filter							
	Torque Limit	Parameter settings / Analog input							
	Bandwidth	Maximum 3.1 kHz (closed-loop)							
	Speed Calibration Ratio ²	±0.01% at 0% to 100% load fluctuation ±0.01% at ±10% power fluctuation ±0.01% at 0°C to 50°C ambient temperature fluctuation							
Torque Control Mode	Analog Command Input	Voltage Range	±10VDC						
		Input Impedance	1MΩ						
		Time Constant	25μs						
	Command Source	External analog command / Internal registers							
	Speed Limit	Parameter settings / Analog input							
Analog Monitor Output		Monitor signal can be set by parameters (voltage output range: ±8V); resolution:10-bit							
Digital Input/Output	Input	Servo on, Fault reset, Gain switch, Pulse clear, Zero speed clamping, Command input reverse control, Internal position command trigger, Torque limit, Speed limit, Internal position command selection, Motor stop, Speed command selection, Speed / position mode switching, Speed / torque mode switching, Torque / position mode switching, PT / PR command switching, Emergency Stop, Forward / reverse limit, Original point, Forward / reverse operation torque limit, Homing activated, E-Cam engage, Forward / reverse JOG input, Event trigger, E-Gear N selection, Pulse input prohibition							
	Output	A, B, Z line driver output Servo ready, Servo on, Zero speed detection, Target speed reached, Target position reached, Torque limiting, Servo alarm, Magnetic brake control, Homing completed, Early warning for overload, Servo warning, Position command overflows, Software limit (reverse direction), Software limit (forward direction), Internal position command completed, Capture procedure completed, Servo procedure completed, Master position area of E-Cam.							

1 - Within the rated load, the speed ratio is: the minimum speed (smooth operation) / rated speed.

2 - Within the rated speed, the speed calibration ratio is: (rotational speed with no load - rotational speed with full load) / rated speed.



AC Servo Drive Specifications

460V Servo drive specifications (continued)

SureServo2 460V Drive Specifications Continued								
Model	SV2A-4040	SV2A-4075	SV2A-4150	SV2A-4200	SV2A-4300	SV2A-4550	SV2A-4750	SV2A-4F00
Protection Function	Overcurrent, Overvoltage, Undervoltage, Overheat, Regeneration error, Overload, Excessive speed deviation, Excessive position deviation, Encoder error, Adjustment error, Emergency stop, Forward / reverse limit error, Excessive deviation of full-closed loop control, Serial communication error, RST leak phase, Serial communication timeout, Short-circuit protection for terminals U, V, W and CN1, CN2, CN3							
Communication Interface	RS-485 / USB							
Weight [kg (lb)]	5.96 [13.1]	5.96 [13.1]	5.96 [13.1]	9.71 [21.4]	9.71 [21.4]	12.14 [26.8]	12.14 [26.8]	15.01 [33.1]
Environment	Installation Site	Indoors (avoid direct sunlight), no corrosive vapor (avoid fumes, flammable gases, and dust)						
	Altitude	1000m or lower above sea level						
	Atmospheric Pressure	86kPa – 106kPa						
	Operating Temperature	0°C to 55°C [32°F to 131°F] (If operating temperature is above 45°C, forced cooling is required)						
	Storage Temperature	-20°C to 65°C [-4°F to 149°F]						
	Humidity	Under 90% RH (non-condensing)						
	Vibration	9.80665 m/s ² (1 G) less than 20 Hz, 5.88 m/s ² (0.6 G) 20 to 50 Hz						
	IP Rating	IP20						
Power System	TN system ^{3,4}							
Approvals	IEC/EN 61800-5-1, UL 508C, TUV (for STO), CE							

3 - TN system: the neutral point of the power system connects directly to the ground. The exposed metal components connect to the ground through the protective ground conductor.

4 - Use a single-phase three-wire power system for the single-phase power model.

AC Servo Motor Specifications

Servo motor overview

24-bit Encoder Connector
1-foot cable with 9-position connector
(Motor-mounted connector is IP67, end-of-cable connector is not liquid tight)

IP67 Housing

Low Inertia Motors

- 100W 40 mm flange
- 200W 60 mm flange
- 400W 60 mm flange
- 750W 80 mm flange

750W and below

Motor Power and Brake Connector
1-foot cable with 6-position connector
(Motor-mounted connector is IP67, end-of-cable connector is not liquid tight)

Keyed Shafts

- 100W 8 mm diameter
- 200W 14 mm diameter
- 400W 14 mm diameter
- 750W 19 mm diameter

With Shaft Seal (liquid tight)

All SureServo2 motors have keyed shafts for use with servo-grade clamp or compression couplings (recommended) or servo-grade keyed couplings.

Motor Power and Brake Connector
(Liquid tight when using AutomationDirect cables)

24-bit Encoder Connector
(Liquid tight when using AutomationDirect cables)

IP67 Housing (IP65 connectors)

1 kW and above

Low, Medium, and High Inertia Motors

- Low Inertia Model:
 - 1kW 100mm flange
 - 1.5 kW 130mm flange
 - 2kW 130mm flange
- Medium Inertia Models:
 - 1kW 130mm flange
 - 1.5kW 130mm flange
 - 2kW 180mm flange
 - 3kW 180mm flange
- High Inertia Models:
 - 3.0kW 180mm flange
 - 4.5kW 180mm flange
 - 5.5kW 180mm flange
 - 7.5kW 180mm flange
 - 11kW 220mm flange
 - 15kW 220mm flange

Keyed Shafts

- Low Inertia Model:
 - 1kW 22mm diameter
 - 1.5 kW 22mm diameter
 - 2kW 22mm diameter
- Medium Inertia Models:
 - 1kW 22mm diameter
 - 1.5kW 22mm diameter
 - 2kW 35mm diameter
 - 3kW 35mm diameter
- High Inertia Models:
 - 3.0kW 35mm diameter
 - 4.5kW 35mm diameter
 - 5.5kW 42mm diameter
 - 7.5kW 42mm diameter
 - 11kW 42mm diameter
 - 15kW 55mm diameter

With Shaft Seal (liquid tight)



AC Servo Motor Specifications

230V Low Inertia Motor Specifications

230V SureServo2 Low Inertia Motor Specifications										
Model	SV2L-201N	SV2L-201B	SV2L-202N	SV2L-202B	SV2L-204N	SV2L-204B	SV2L-207N	SV2L-207B	SV2L-210N	SV2L-210B
Price	\$286.00	\$419.00	\$315.00	\$465.00	\$340.00	\$479.00	\$364.00	\$510.00	\$477.00	\$702.00
Drawing	PDF	PDF	PDF	PDF	PDF	PDF	PDF	PDF	PDF	PDF
Rated Power [kW]	0.1	0.1	0.2	0.2	0.4	0.4	0.75	0.75	1.0	1.0
Rated Torque [N-m]Note 1	0.32	0.32	0.64	0.64	1.27	1.27	2.39	2.39	3.18	3.18
Max. Torque [N-m]	1.12	1.12	2.24	2.24	3.96	3.96	7.86	7.86	8.12	8.12
Rated Speed [rpm]	3000									
Max. Speed [rpm]	6000								5000	
Rated current [Amps] rms	0.9	0.9	1.45	1.45	2.60	2.60	4.5	4.5	8.04	8.04
Max. Instantaneous Current [Amps] rms	3.3	3.3	5.4	5.4	8.56	8.56	15.41	15.41	20.16	20.16
Change of Rated Power [W/s]	16.3	14.90	16.4	14.60	35.8	33.60	37.8	34.40	38.2	30.40
Rotor Inertia [x10 ⁻⁴ kg m ²]	0.0627	0.0689	0.25	0.28	0.45	0.48	1.51	1.66	2.65	3.33
Mechanical Time Constant [ms]	1.13	1.24	1.38	1.54	0.94	1.01	0.91	1.00	0.83	1.05
Torque Constant-KT [N-m/A]	0.356	0.356	0.441	0.441	0.488	0.488	0.531	0.531	0.396	0.396
Voltage Constant-KE [mV/rpm]	13.66	13.66	16.4	16.4	17.2	17.2	18.7	18.7	16.8	16.8
Armature Resistance [Ohm]	8.34	8.34	3.8	3.8	1.68	1.68	0.57	0.57	0.20	0.20
Armature Inductance [mH]	9.85	9.85	8.15	8.15	4.03	4.03	2.2	2.2	1.81	1.81
Electrical Time Constant [ms]	1.18	1.18	2.14	2.14	2.40	2.40	3.86	3.86	9.05	9.05
Insulation Class	Class A (UL), Class B (CE)									
Insulation Resistance	> 100MΩ, 500VDC									
Insulation Strength	1.8 kVAC, 1 second									
Weight [kg]	0.5	0.8	1.1	1.6	1.4	1.9	2.8	3.6	4.3	4.7
Max. Radial Loading [N]	78	78	245	245	245	245	392	392	490	490
Max. Axial Loading [N]	54	54	74	74	74	74	147	147	98	98
Brake Holding Torque [N-m (min)]Note 2	n/a	0.32	n/a	1.3	n/a	1.3	n/a	2.5	n/a	8
Brake Power Consumption (at 20°C) [W]	n/a	6.1	n/a	7.2	n/a	7.2	n/a	8	n/a	18.7
Brake Release Time [ms (max)]	n/a	20	n/a	20	n/a	20	n/a	20	n/a	10
Brake Pull-in Time [ms (max)]	n/a	35	n/a	50	n/a	50	n/a	60	n/a	70
Vibration Grade [μm]	V15									
Operating Temperature [°C]	0–40 °C (32–104 °F)									
Storage Temperature [°C]	-10°C to 80°C (-14°F to 176°F)									
Operating Humidity	20–90% relative humidity (non-condensing)									
Storage Humidity	20–90% relative humidity (non-condensing)									
Vibration Capacity	2.5 G									
IP Rating ³	IP67 (when using waterproof connectors)								IP65 (when using waterproof connectors)	
Encoder Resolution	24-bit (16777216 p/rev)									
Agency Approvals	cUR _{US} , CE									

Note 1—The rated torque is the continuous permissible torque between the 0°C and 40°C operating temperature which is suitable for a servo motor mounted with the following heat sink dimensions: 250mm x 250mm x 6mm made from aluminum (or mounted to equipment with an equivalent heat sinking capability).

Note 2—The built-in servo motor brake is only for holding the load in a stopped state. Do not use for deceleration or as a dynamic brake.

Note 3—All SureServo2 motors are shipped with oil seals installed for IP rating requirements.



AC Servo Motor Specifications

230V Medium Inertia Motor Specifications

230V SureServo2 Medium Inertia Motor Specifications								
Model	SV2M-210N	SV2M-210B	SV2M-215N	SV2M-215B	SV2M-220N	SV2M-220B	SV2M-230N	SV2M-230B
Price	\$497.00	\$711.00	\$537.00	\$795.00	\$651.00	\$863.00	\$735.00	\$947.00
Drawing	PDF	PDF	PDF	PDF	PDF	PDF	PDF	PDF
Rated Power [kW]	1.0	1.0	1.5	1.5	2.0	2.0	3.0	3.0
Rated Torque [N·m]Note 1	4.77	4.77	7.16	7.16	9.55	9.55	17.55	17.55
Max. Torque [N·m]	14.32	14.32	14.88	14.88	24.54	24.54	48.29	48.29
Rated Speed [rpm]	2000						1700	
Max. Speed [rpm]	3000							
Rated current [Amps] rms	5.66	5.66	8.33	8.33	12.1	12.1	17.9	17.9
Max. Instantaneous Current [Amps] rms	19.73	19.73	20.16	20.16	33.66	33.66	55.93	55.93
Change of Rated Power [W/s]	27.1	24.90	45.8	43.10	26.3	24.10	56.0	53.90
Rotor Inertia [x10 ⁻⁴ kg m ²]	8.41	9.14	11.2	11.9	34.7	37.8	55	57.1
Mechanical Time Constant [ms]	1.54	1.67	1.12	1.18	1.75	1.90	1.29	1.34
Torque Constant-KT [N·m/A]	0.843	0.843	0.860	0.860	0.789	0.789	0.980	0.980
Voltage Constant-KE [mV/rpm]	31.9	31.9	31.8	31.8	31.4	31.4	35	35
Armature Resistance [Ohm]	0.47	0.47	0.26	0.26	0.119	0.119	0.077	0.077
Armature Inductance [mH]	5.99	5.99	4.01	4.01	2.84	2.84	1.27	1.27
Electrical Time Constant [ms]	12.74	12.74	15.42	15.42	23.87	23.87	16.49	16.49
Insulation Class	Class A (UL), Class B (CE)							
Insulation Resistance	> 100MΩ, 500VDC							
Insulation Strength	1.8 kVAC, 1 second							
Weight [kg]	7.0	8.4	7.5	8.9	13.5	17.5	18.5	22.5
Max. Radial Loading [N]	490				1176		1470	
Max. Axial Loading [N]	98				490			
Brake Holding Torque [N·m (min)]Note 2	n/a	10	n/a	10	n/a	25	n/a	25
Brake Power Consumption (at 20°C) [W]		19		19		20.4		20.4
Brake Release Time [ms (max)]		10		10		10		10
Brake Pull-in Time [ms (max)]		70		70		70		70
Vibration Grade [μm]	V15							
Operating Temperature [°C]	0–40 °C (32–104 °F)							
Storage Temperature [°C]	-10°C to 80°C (-14°F to 176°F)							
Operating Humidity	20–90% relative humidity (non-condensing)							
Storage Humidity	20–90% relative humidity (non-condensing)							
Vibration Capacity	2.5 G							
IP Rating ³	IP65 (when using waterproof connectors)							
Encoder Resolution	24-bit (16777216 p/rev)							
Agency Approvals	cUR _{US} , CE							

Note 1—The rated torque is the continuous permissible torque between the 0°C and 40°C operating temperature which is suitable for a servo motor mounted with the following heat sink dimensions: 250mm x 250mm x 6mm made from aluminum (or mounted to equipment with an equivalent heat sinking capability).

Note 2—The built-in servo motor brake is only for holding the load in a stopped state. Do not use for deceleration or as a dynamic brake.

Note 3—All SureServo2 motors are shipped with oil seals installed for IP rating requirements.



AC Servo Motor Specifications

230V High Inertia Motor Specifications

230V SureServo2 High Inertia Motor Specifications										
Model	SV2H-245N	SV2H-245B	SV2H-255N	SV2H-255B	SV2H-275N	SV2H-275B	SV2H-2B0N	SV2H-2B0B	SV2H-2F0N	SV2H-2F0B
Price	\$911.00	\$1,415.00	\$1,050.00	\$1,568.00	\$1,273.00	\$1,989.00	\$1,956.00	\$2,682.00	\$2,257.00	\$3,091.00
Drawing	PDF	PDF	PDF	PDF	PDF	PDF	PDF	PDF	PDF	PDF
Rated Power [kW]	4.5	4.5	5.5	5.5	7.5	7.5	11	11	15	15
Rated Torque [N·m]Note 1	28.65	28.65	35.01	35.01	47.74	47.74	70	70	95.4	95.4
Max. Torque [N·m]	71.62	71.62	87.53	87.53	119.36	119.36	175	175	224.0	224.0
Rated Speed [rpm]	1500									
Max. Speed [rpm]	3000					2000				
Rated current [Amps] rms	32.5	32.5	40.12	40.12	47.5	47.5	51.1	51.1	67	67
Max. Instantaneous Current [Amps] rms	91.4	91.4	108.0	108.0	127.46	127.46	129.5	129.5	162	162
Change of Rated Power [W/s]	105.6	101.8	122.8	119.3	159.7	156.6	145.0	141.4	201.8	197.1
Rotor Inertia [x10 ⁻⁴ kg m ²]	77.75	80.65	99.78	102.70	142.7	145.55	338	346.5	451	461.8
Mechanical Time Constant [ms]	0.93	0.96	0.97	0.99	0.84	0.85	1.38	1.41	1.22	1.25
Torque Constant-KT [N·m/A]	0.878	0.878	0.873	0.873	1.005	1.005	1.370	1.370	1.424	1.424
Voltage Constant-KE [mV/rpm]	32.0	32.0	31.0	31.0	35.5	35.5	49	49	50	50
Armature Resistance [Ohm]	0.032	0.032	0.025	0.025	0.02	0.02	0.0261	0.0261	0.0184	0.0184
Armature Inductance [mH]	0.89	0.89	0.71	0.71	0.6	0.6	0.65	0.65	0.48	0.48
Electrical Time Constant [ms]	27.81	27.81	28.4	28.4	30.0	30.0	24.9	24.9	26.09	26.09
Insulation Class	Class A (UL), Class B (CE)						Class F (UL), Class F (CE)			
Insulation Resistance	> 100MΩ, 500VDC									
Insulation Strength	1.8 kVAC, 1 second									
Weight [kg]	23.5	29	30.5	36	40.5	46	56.4	68.4	75	87
Max. Radial Loading [N]	1470			1764			3300			
Max. Axial Loading [N]	490			588			1100			
Brake Holding Torque [N·m (min)]Note 2		55.0		55.0		55.0		115		115
Brake Power Consumption (at 20°C) [W]		19.9		19.9		19.9		28.8		28.8
Brake Release Time [ms (max)]	n/a	10	n/a	10	n/a	10	n/a	10	n/a	10
Brake Pull-in Time [ms (max)]		70		70		70		70		70
Vibration Grade [μm]	V15									
Operating Temperature [°C]	0–40 °C (32–104 °F)									
Storage Temperature [°C]	-10°C to 80°C (-14°F to 176°F)									
Operating Humidity	20–90% relative humidity (non-condensing)									
Storage Humidity	20–90% relative humidity (non-condensing)									
Vibration Capacity	2.5 G									
IP Rating ³	IP65 (when using specified cables)									
Encoder Resolution	24-bit (16777216 p/rev)									
Agency Approvals	cURUS, CE									

Note 1—The rated torque is the continuous permissible torque between the 0°C and 40°C operating temperature which is suitable for a servo motor mounted with the following heat sink dimensions:

300mm x 300mm x 12mm, 400mm x 400mm x 20mm, 550mm x 550mm x 30mm

All made from aluminum (or mounted to equipment with an equivalent heat sinking capability)

Note 2—The built-in servo motor brake is only for holding the load in a stopped state. Do not use it for deceleration or as a dynamic brake.

Note 3—All SureServo2 motors are shipped with oil seals installed for IP rating requirements.



AC Servo Motor Specifications

460V Low Inertia Motor Specifications

460V SureServo2 Low Inertia Motor Specifications										
Model	SV2L-404N	SV2L-404B	SV2L-407N	SV2L-407B	SV2L-410N	SV2L-410B	SV2L-415N	SV2L-415B	SV2L-420N	SV2L-420B
Price	\$360.00	\$515.00	\$388.00	\$555.00	\$505.00	\$745.00	\$580.00	\$855.00	\$687.00	\$899.00
Drawing	PDF	PDF	PDF	PDF	PDF	PDF	PDF	PDF	PDF	PDF
Rated Power [kW]	0.4	0.4	0.75	0.75	1.0	1.0	1.5	1.5	2.0	2.0
Rated Torque [N·m]Note 1	1.27	1.27	2.24	2.24	3.18	3.18	7.16	7.16	9.55	9.55
Max. Torque [N·m]	4.45	4.45	7.58	7.58	9.54	9.54	18.1	18.1	28.65	28.65
Rated Speed [rpm]	3000		3200		3000		2000			
Max. Speed [rpm]	6000		6000		5000		3000			
Rated current [Amps] rms	1.43	1.43	2.90	2.90	4.36	4.36	5.1	5.1	6.7	6.7
Max. Instantaneous Current [Amps] rms	5.25	5.25	9.70	9.70	13.74	13.74	13.28	13.28	21.35	21.35
Change of Rated Power [W/s]	35.8	33.6	33.2	30.2	38.2	30.40	45.9	43.10	62.5	57.4
Rotor Inertia [x10 ⁻⁴ kg m ²]	0.45	0.48	1.51	1.66	2.65	3.33	11.18	11.9	14.59	15.88
Mechanical Time Constant [ms]	1.05	1.12	1.02	1.12	0.81	1.02	1.26	1.34	1.11	1.21
Torque Constant-KT [N·m/A]	0.888	0.888	0.772	0.772	0.729	0.729	1.404	1.404	1.425	1.425
Voltage Constant-KE [mV/rpm]	31.83	31.83	27.83	27.83	29.00	29.00	55.00	55.00	55.00	55.00
Armature Resistance [Ohm]	6.28	6.28	1.38	1.38	0.617	0.617	0.83	0.83	0.57	0.57
Armature Inductance [mH]	13.34	13.34	4.78	4.78	6.03	6.03	11.67	11.67	8.29	8.29
Electrical Time Constant [ms]	2.12	2.12	3.46	3.46	9.77	9.77	14.06	14.06	14.54	14.54
Insulation Class	Class A (UL), Class B (CE)									
Insulation Resistance	> 100 MΩ, 500VDC									
Insulation Strength	2.3 kVAC, 1 sec									
Weight [kg]	1.4	1.9	2.8	3.6	4.3	4.7	7.5	8.9	7.8	9.2
Max. Radial Loading [N]	245	245	392	392	490	490	490	490	490	490
Max. Axial Loading [N]	74	74	147	147	98	98	98	98	98	98
Brake Holding Torque [N·m (min)]Note 2	n/a	1.3	n/a	2.5	n/a	8	n/a	10	n/a	10
Brake Power Consumption (at 20°C) [W]		7.2		8		18.7		19		19
Brake Release Time [ms (max)]		20		20		10		10		10
Brake Pull-in Time [ms (max)]		50		60		70		70		70
Vibration Grade [μm]	V15									
Operating Temperature [°C]	0–40 °C (32–104 °F)									
Storage Temperature [°C]	-10°C to 80°C (-14°F to 176°F)									
Operating Humidity	20–90% relative humidity (non-condensing)									
Storage Humidity	20–90% relative humidity (non-condensing)									
Vibration Capacity	2.5 G									
IP Rating	IP67 (when using waterproof connectors and when an oil seal is fitted to the rotating shaft (for an oil seal model))				IP65 (when using waterproof connectors and when an oil seal is fitted to the rotating shaft (for an oil seal model))					
Encoder Resolution	24-bit (16777216 p/rev)									
Agency Approvals	cURUS, CE									

Note 1—The rated torque is the continuous permissible torque between the 0°C and 40°C operating temperature which is suitable for a servo motor mounted with the following heat sink dimensions: 250mm x 250mm x 6mm made from aluminum (or mounted to equipment with an equivalent heat sinking capability).

Note 2—The built-in servo motor brake is only for holding the load in a stopped state. Do not use for deceleration or as a dynamic brake.



AC Servo Motor Specifications

460V Medium Inertia Motor Specifications

460V SureServo2 Medium Inertia Motor Specifications		
Model	SV2M-410N	SV2M-410B
Price	\$530.00	\$765.00
Drawing	PDF	PDF
Rated Power [kW]	1.0	1.0
Rated Torque [N·m]Note 1	4.77	4.77
Max. Torque [N·m]	14.32	14.32
Rated Speed [rpm]	2000	
Max. Speed [rpm]	3000	
Rated current [Amps] rms	3.6	3.6
Max. Instantaneous Current [Amps] rms	11.41	11.41
Change of Rated Power [W/s]	27.1	24.90
Rotor Inertia [x10 ⁻⁴ kg m ²]	8.41	9.14
Mechanical Time Constant [ms]	1.85	2.01
Torque Constant-KT [N·m/A]	1.325	1.325
Voltage Constant-KE [mV/rpm]	53.20	53.20
Armature Resistance [Ohm]	1.477	1.477
Armature Inductance [mH]	17.79	17.79
Electrical Time Constant [ms]	12.04	12.04
Insulation Class	Class A (UL), Class B (CE)	
Insulation Resistance	> 100 MΩ, 500VDC	
Insulation Strength	2.3 kVAC, 1 sec	
Weight [kg]	7.0	8.4
Max. Radial Loading [N]	490	
Max. Axial Loading [N]	98	
Brake Holding Torque [N·m (min)]Note 2		10
Brake Power Consumption (at 20°C) [W]	n/a	19
Brake Release Time [ms (max)]		10
Brake Pull-in Time [ms (max)]		70
Vibration Grade [μm]	V15	
Operating Temperature [°C]	0–40 °C (32–104 °F)	
Storage Temperature [°C]	-10°C to 80°C (-14°F to 176°F)	
Operating Humidity	20–90% relative humidity (non-condensing)	
Storage Humidity	20–90% relative humidity (non-condensing)	
Vibration Capacity	2.5 G	
IP Rating	IP65 (when using waterproof connectors and when an oil seal is fitted to the rotating shaft (for an oil seal model))	
Encoder Resolution	24-bit (16777216 p/rev)	
Agency Approvals	cUR _{US} , CE	

Note 1—The rated torque is the continuous permissible torque between the 0°C and 40°C operating temperature which is suitable for a servo motor mounted with the following heat sink dimensions: 250mm x 250mm x 6mm made from aluminum (or mounted to equipment with an equivalent heat sinking capability).

Note 2—The built-in servo motor brake is only for holding the load in a stopped state. Do not use for deceleration or as a dynamic brake.



AC Servo Motor Specifications

460V High Inertia Motor Specifications

460V SureServo2 High Inertia Motor Specifications						
Model	SV2H-430N	SV2H-430B	SV2H-445N	SV2H-445B	SV2H-455N	SV2H-455B
Price	\$823.00	\$1,001.00	\$939.00	\$1,456.00	\$1,082.00	\$1,614.00
Drawing	PDF	PDF	PDF	PDF	PDF	PDF
Rated Power [kW]	3.0	3.0	4.5	4.5	5.5	5.5
Rated Torque [N·m]Note 1	19.1	19.1	28.65	28.65	35	35
Max. Torque [N·m]	49.38	49.38	64.61	64.61	73.48	73.48
Rated Speed [rpm]	1500					
Max. Speed [rpm]	3000					
Rated current [Amps] rms	12.2	12.2	21.9	21.9	23.6	23.6
Max. Instantaneous Current [Amps] rms	30.46	30.46	47.5	47.5	47.5	47.5
Change of Rated Power [W/s]	66.4	63.9	105.6	101.8	122.8	119.3
Rotor Inertia [x10 ⁻⁴ kg m ²]	54.95	57.1	77.75	80.65	99.78	80.65
Mechanical Time Constant [ms]	1.20	1.24	1.06	1.10	0.84	0.86
Torque Constant-KT [N·m/A]	1.566	1.566	1.308	1.308	1.483	1.483
Voltage Constant-KE [mV/rpm]	64.4	64.4	53.00	53.00	58.9	58.9
Armature Resistance [Ohm]	0.21	0.21	0.09	0.09	0.07	0.07
Armature Inductance [mH]	4.94	4.94	2.36	2.36	2.20	2.20
Electrical Time Constant [ms]	23.52	23.52	26.22	26.22	31.43	31.43
Insulation Class	Class A (UL), Class B (CE)					
Insulation Resistance	> 100 MΩ, 500VDC					
Insulation Strength	2.3 kVAC, 1 sec					
Weight [kg]	18.5	22.5	23.5	29	30.5	36
Max. Radial Loading [N]	1470				1764	
Max. Axial Loading [N]	490				588	
Brake Holding Torque [N·m (min)]Note 2	25		55		55	
Brake Power Consumption (at 20°C) [W]	20.4		19.9		19.9	
Brake Release Time [ms (max)]	10		10		10	
Brake Pull-in Time [ms (max)]	70		70		70	
Vibration Grade [μm]	V15					
Operating Temperature [°C]	0–40 °C (32–104 °F)					
Storage Temperature [°C]	-10°C to 80°C (-14°F to 176°F)					
Operating Humidity	20–90% relative humidity (non-condensing)					
Storage Humidity	20–90% relative humidity (non-condensing)					
Vibration Capacity	2.5 G					
IP Rating	IP65 (when using waterproof connectors and when an oil seal is fitted to the rotating shaft (for an oil seal model))					
Encoder Resolution	24-bit (16777216 p/rev)					
Agency Approvals	cUR _{US} , CE					

Continued on next page

Note 1–The rated torque is the continuous permissible torque between the 0°C and 40°C operating temperature which is suitable for a servo motor mounted with the following heat sink dimensions:

300mm x 300mm x 12mm

400mm x 400mm x 20mm

550mm x 550mm x 30mm

All made from aluminum (or mounted to equipment with an equivalent heat sinking capability)

Note 2–The built-in servo motor brake is only for holding the load in a stopped state. Do not use it for deceleration or as a dynamic brake.



AC Servo Motor Specifications

460V High Inertia Motor Specifications, *continued*

460V SureServo2 High Inertia Motor Specifications						
Model	SV2H-475N	SV2H-475B	SV2H-4B0N	SV2H-4B0B	SV2H-4F0N	SV2H-4F0B
Price	\$1,311.00	\$2,047.00	\$2,014.00	\$2,760.00	\$2,324.00	\$3,182.00
Drawing	PDF	PDF	PDF	PDF	PDF	PDF
Rated Power [kW]	7.5	7.5	11	11	15	15
Rated Torque [N·m]Note 1	47.74	47.74	70	70	95.4	95.4
Max. Torque [N·m]	93.71	93.71	175	175	224.0	224.0
Rated Speed [rpm]	1500		1500			
Max. Speed [rpm]	3000		2000			
Rated current [Amps] rms	28.7	28.7	26.8	26.8	37.5	37.5
Max. Instantaneous Current [Amps] rms	57.69	57.69	67.7	67.7	95.3	95.3
Change of Rated Power [W/s]	159.7	156.6	145.0	141.4	201.8	197.1
Rotor Inertia [x10 ⁻⁴ kg m ²]	142.7	145.5	338	346.5	451	461.8
Mechanical Time Constant [ms]	0.81	0.83	1.40	1.44	1.21	1.23
Torque Constant-KT [N·m/A]	1.663	1.663	2.612	2.612	2.544	2.544
Voltage Constant-KE [mV/rpm]	66.40	66.40	96.00	96.00	83.90	83.90
Armature Resistance [Ohm]	0.06	0.06	0.0994	0.0994	0.0545	0.0545
Armature Inductance [mH]	1.70	1.70	2.51	2.51	1.43	1.43
Electrical Time Constant [ms]	28.33	28.33	25.25	25.25	26.24	26.24
Insulation Class	Class A (UL), Class B (CE)		Class F (UL), Class F (CE)			
Insulation Resistance	> 100 MΩ, 500VDC					
Insulation Strength	2.3 kVAC, 1 sec					
Weight [kg]	40.5	46	56.4	68.4	75	87
Max. Radial Loading [N]	1764		3300			
Max. Axial Loading [N]	588		1100			
Brake Holding Torque [N·m (min)]Note 2	n/a	55	n/a	115	n/a	115
Brake Power Consumption (at 20°C) [W]		19.9		28.8		28.8
Brake Release Time [ms (max)]		10		10		10
Brake Pull-in Time [ms (max)]		70		70		70
Vibration Grade [μm]	V15					
Operating Temperature [°C]	0–40 °C (32–104 °F)					
Storage Temperature [°C]	-10°C to 80°C (-14°F to 176°F)					
Operating Humidity	20–90% relative humidity (non-condensing)					
Storage Humidity	20–90% relative humidity (non-condensing)					
Vibration Capacity	2.5 G					
IP Rating	IP65 (when using waterproof connectors and when an oil seal is fitted to the rotating shaft (for an oil seal model))					
Encoder Resolution	24-bit (16777216 p/rev)					
Agency Approvals	cUR _{US} , CE					

Note 1—The rated torque is the continuous permissible torque between the 0°C and 40°C operating temperature which is suitable for a servo motor mounted with the following heat sink dimensions:

300mm x 300mm x 12mm

400mm x 400mm x 20mm

550mm x 550mm x 30mm

All made from aluminum (or mounted to equipment with an equivalent heat sinking capability)

Note 2—The built-in servo motor brake is only for holding the load in a stopped state. Do not use it for deceleration or as a dynamic brake.

Standard wiring example, 230V Systems

24V Open-collector pulse command input

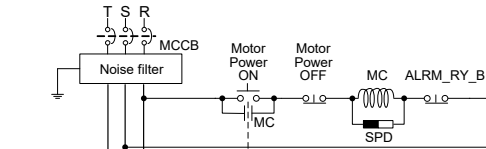
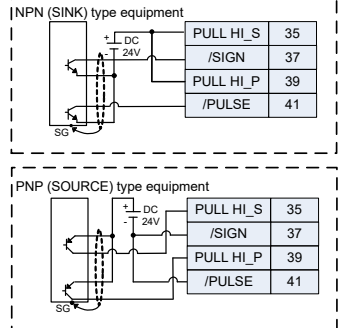

Inputs SIGN (36) and PULSE (43) are designed for Line Driver (differential) signals. Do not use with 24V. For 5V open collector applications, see section 3.5 in the User Manual.

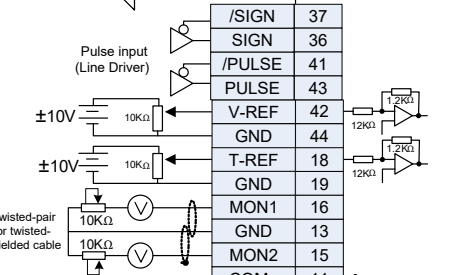

Digital Input Rating:
ON: 15 - 24V_{DC}, 8mA
OFF: <5V_{DC}, <0.5 mA

Digital Output Rating:
Max 30V_{DC}, Max 40mA

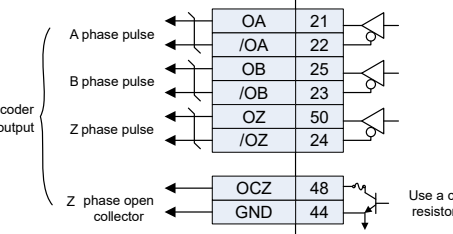
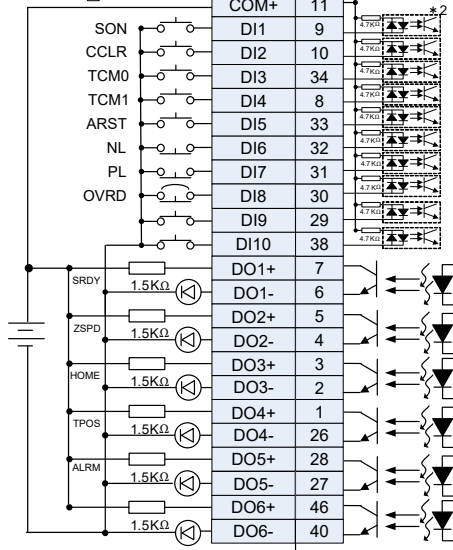
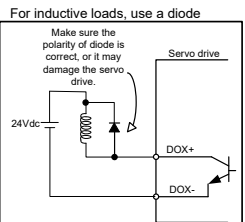

Max. output current: 50mA
Max. voltage: 30V

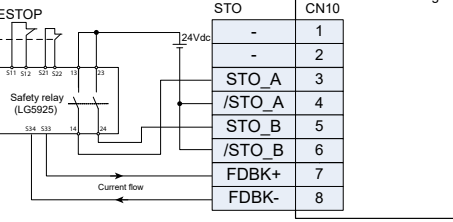

NOTE: Polarity between terminals S33/S34 and FDBK+/- must be correct. If polarity is reversed, enough leakage current will flow through the drive transistor to satisfy the reset circuit of the safety relay.

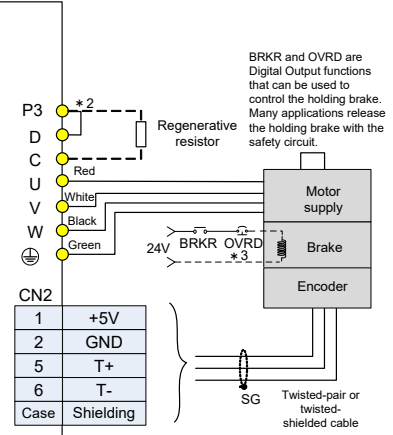

BRKR and OVRD are Digital Output functions that can be used to control the holding brake. Many applications release the holding brake with the safety circuit.

1	+5V
2	GND
5	T+
6	T-
Case	Shielding

6,8	-
5	RS485+
4	RS485-
3,7	GND_ISO
2	-
1	-

Mini USB	
----------	--

8	+5V
4	Opt A
5	Opt /A
3	Opt B
2	Opt /B
9	Opt Z
1	Opt /Z
6	GND
7	GND
10	-
11	-
12	-
13	-
14	-
15	-

This wiring diagram shows basic wiring only, and additional wiring configurations are possible for some I/O. Refer to the "Installation and Wiring" chapter of the User Manual for more detailed wiring information.



AC Servo System Wiring

Standard wiring example, 460V Systems

This wiring diagram shows basic wiring only, and additional wiring configurations are possible for some I/O. Refer to the "Installation and Wiring" chapter of the User Manual for more detailed wiring information.

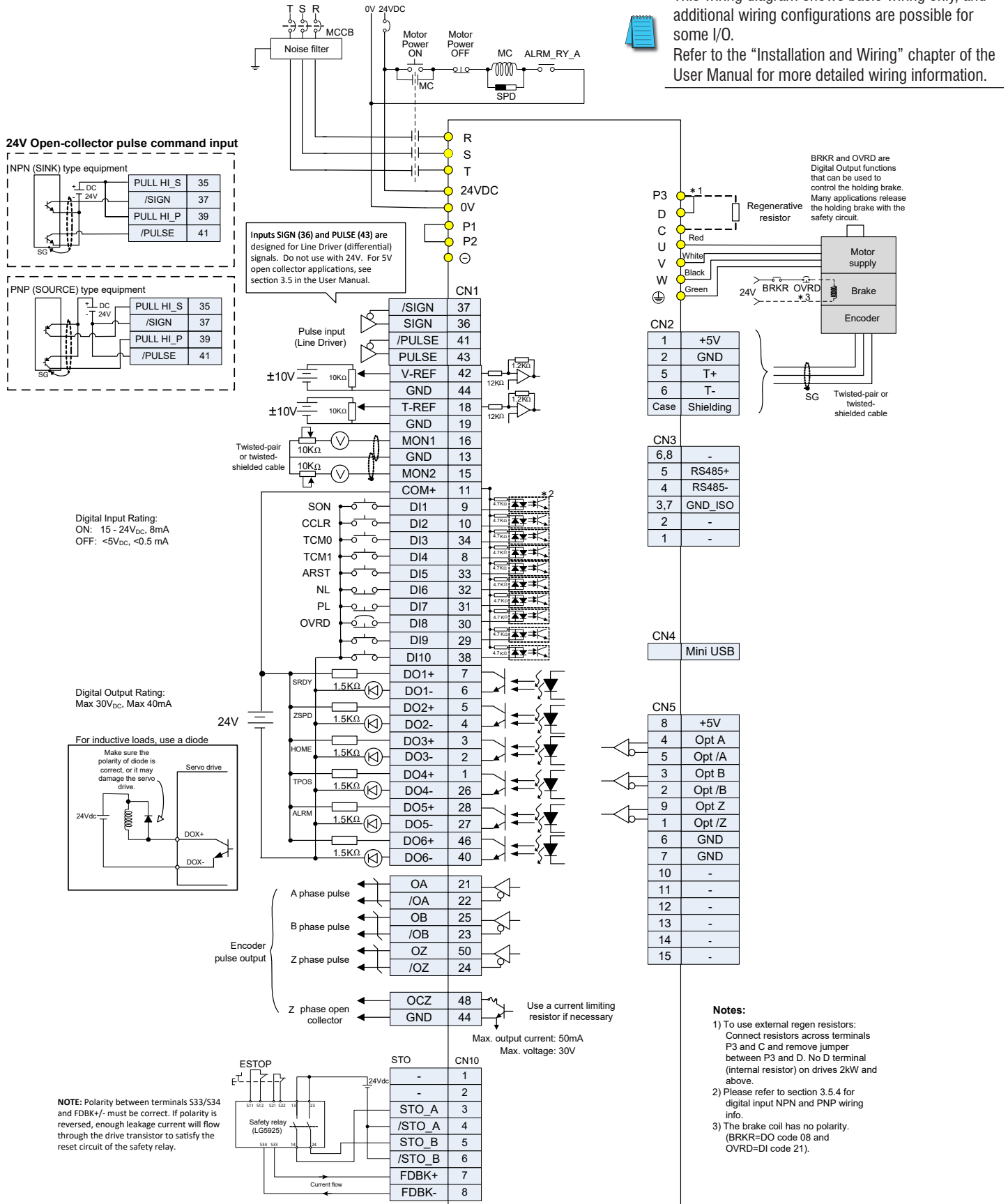

Servo drive dimensions

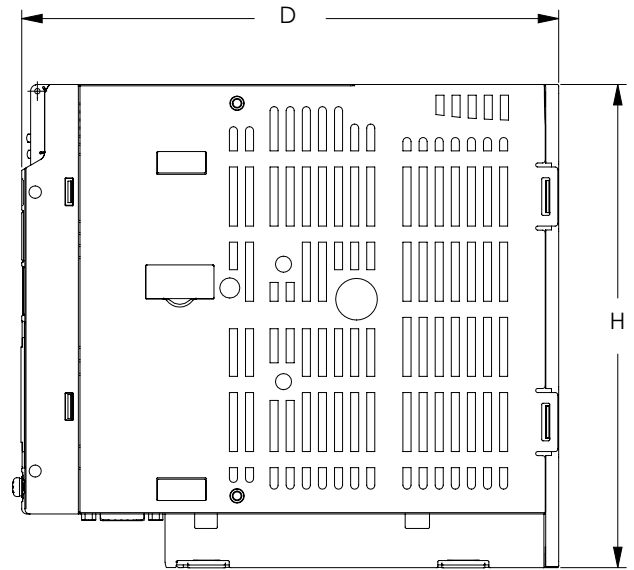
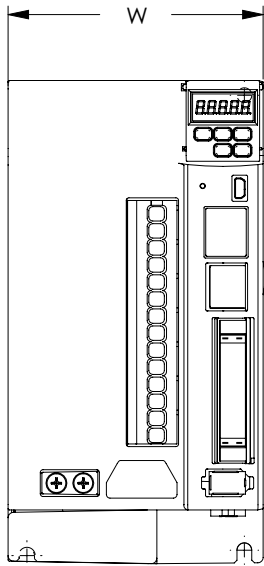

SureServo2 Drive Dimensions				
Model	Drawing Link	W mm [inches]	D mm [inches]	H mm [inches]
SV2A-2040	PDF	35 [1.38]	170 [6.69]	170 [6.69]
SV2A-2075	PDF	50 [1.97]	180 [7.09]	180 [7.09]
SV2A-2150	PDF	50 [1.97]	180 [7.09]	180 [7.09]
SV2A-2200	PDF	95 [3.74]	200 [7.87]	180 [7.09]
SV2A-2300	PDF	95 [3.74]	200 [7.87]	180 [7.09]
SV2A-2550	PDF	120 [4.72]	206 [8.12]	273 [10.75]
SV2A-2750	PDF	141 [5.56]	226 [8.90]	312 [12.28]
SV2A-2F00	PDF	186 [7.32]	281 [11.08]	390 [15.35]
SV2A-4040	PDF	65 [2.55]	204 [8.03]	180 [7.09]
SV2A-4075	PDF	65 [2.55]	204 [8.03]	180 [7.09]
SV2A-4150	PDF	65 [2.55]	204 [8.03]	180 [7.09]
SV2A-4200	PDF	110 [4.33]	200.8 [7.9]	260 [10.24]
SV2A-4300	PDF	110 [4.33]	200.8 [7.9]	260 [10.24]
SV2A-4550	PDF	110 [4.33]	200.8 [7.9]	260 [10.24]
SV2A-4750	PDF	120 [4.72]	206.3 [8.12]	273 [10.75]
SV2A-4F00	PDF	141 [5.55]	225.5 [8.88]	312 [12.28]



For additional dimensions, see the AutomationDirect website or click on the drawing links.



Requires 2" above and below the drive for air flow. For proper air flow clearance, please see section 2.3.1 of the SureServo2 User Manual.



For cabinet depth, add approximately 100mm (4 inches) for CN1 (I/O) and CN2 (encoder) cable bend radius.

230V Servo motor dimensions

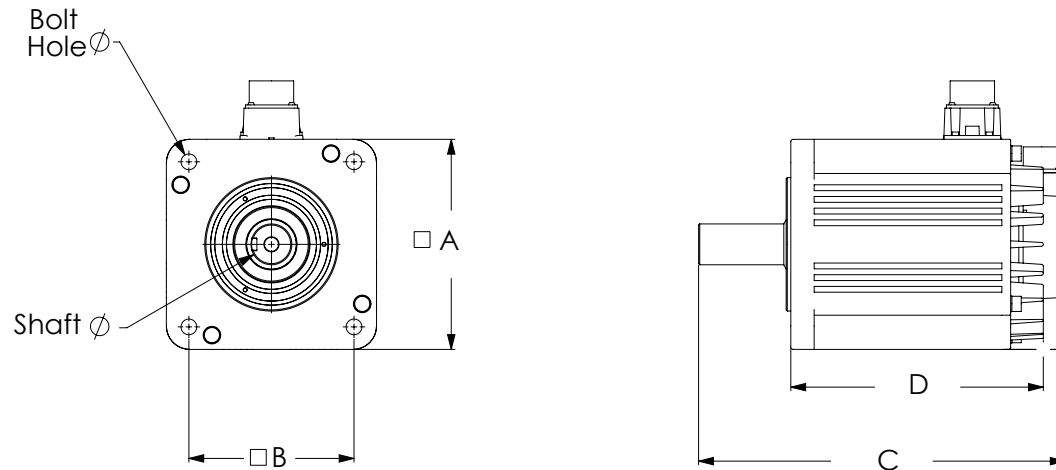

SureServo2 230V Motor Dimensions							
Model	Drawing Link	A mm [inches]	B mm [inches]	C mm [inches]	D mm [inches]	Bolt Hole Ø mm [inches]	Shaft Ø mm [inches]
SV2L-201N	PDF	40.0 [1.57]	32.2 [1.27]	110.3 [4.34]	85.3 [3.36]	4.5 [0.18]	8.0 [0.31]
SV2L-201B	PDF	40.0 [1.57]	32.2 [1.27]	145.1 [5.71]	120.1 [4.73]	4.5 [0.18]	8.0 [0.31]
SV2L-202N	PDF	60.0 [2.36]	49.5 [1.95]	113.9 [4.49]	84.0 [3.31]	5.5 [0.22]	14.0 [0.55]
SV2L-202B	PDF	60.0 [2.36]	49.5 [1.95]	147.6 [5.81]	117.1 [4.61]	5.5 [0.22]	14.0 [0.55]
SV2L-204N	PDF	60.0 [2.36]	49.5 [1.95]	136.0 [5.35]	106.0 [4.17]	5.5 [0.22]	14.0 [0.55]
SV2L-204B	PDF	60.0 [2.36]	49.5 [1.95]	169.7 [6.68]	139.7 [5.50]	5.5 [0.22]	14.0 [0.55]
SV2L-207N	PDF	80.0 [3.15]	63.6 [2.51]	155.8 [6.13]	115.8 [4.56]	6.6 [2.51]	19.0 [0.75]
SV2L-207B	PDF	80.0 [3.15]	63.6 [2.51]	193.2 [7.61]	153.2 [6.03]	6.6 [2.51]	19.0 [0.75]
SV2L-210N	PDF	100.0 [3.94]	81.3 [3.20]	198.3 [7.81]	110.2 [4.34]	9.0 [0.35]	22.0 [0.87]
SV2L-210B	PDF	100.0 [3.94]	81.3 [3.20]	237.5 [9.35]	149.5 [5.89]	9.0 [0.35]	22.0 [0.87]
SV2M-210N	PDF	130.0 [5.12]	102.5 [4.04]	202.5 [7.97]	104.5 [4.11]	9.0 [0.35]	22.0 [0.87]
SV2M-210B	PDF	130.0 [5.12]	102.5 [4.04]	238.5 [9.39]	140.5 [5.53]	9.0 [0.35]	22.0 [0.87]
SV2M-215N	PDF	130.0 [5.12]	102.5 [4.04]	222.5 [8.76]	120.5 [4.74]	9.0 [0.35]	22.0 [0.87]
SV2M-215B	PDF	130.0 [5.12]	102.5 [4.04]	257.0 [10.12]	155.0 [6.10]	9.0 [0.35]	22.0 [0.87]
SV2M-220N	PDF	180.0 [7.09]	141.4 [5.57]	247.7 [9.75]	150.0 [5.91]	13.5 [0.53]	35.0 [1.38]
SV2M-220B	PDF	180.0 [7.09]	141.4 [5.57]	281.8 [11.09]	184.1 [7.25]	13.5 [0.53]	35.0 [1.38]
SV2M-230N	PDF	180.0 [7.09]	141.4 [5.57]	280.8 [11.06]	183.1 [7.21]	13.5 [0.53]	35.0 [1.38]
SV2M-230B	PDF	180.0 [7.09]	141.4 [5.57]	314.0 [12.36]	216.3 [8.52]	13.5 [0.53]	35.0 [1.38]
SV2H-245N	PDF	180.0 [7.09]	141.4 [5.57]	314.0 [12.36]	216.3 [8.52]	13.5 [0.53]	35.0 [1.38]
SV2H-245B	PDF	180.0 [7.09]	141.4 [5.57]	358.0 [14.09]	260.3 [10.25]	13.5 [0.53]	35.0 [1.38]
SV2H-255N	PDF	180.0 [7.09]	141.4 [5.57]	392.4 [15.45]	260.7 [10.26]	13.5 [0.53]	42.0 [1.63]
SV2H-255B	PDF	180.0 [7.09]	141.4 [5.57]	424.4 [16.71]	292.7 [11.52]	13.5 [0.53]	42.0 [1.63]
SV2H-275N	PDF	180.0 [7.09]	141.4 [5.57]	454.7 [17.9]	323.0 [12.72]	13.5 [0.53]	42.0 [1.63]
SV2H-275B	PDF	180.0 [7.09]	141.4 [5.57]	488.8 [19.24]	357.1 [14.06]	13.5 [0.53]	42.0 [1.63]
SV2H-2B0N	PDF	219.9 [8.66]	166.2 [6.54]	487.4 [19.19]	319.0 [12.56]	13.5 [0.53]	42.0 [1.63]
SV2H-2B0B	PDF	219.9 [8.66]	166.2 [6.54]	550.4 [21.67]	382.0 [15.04]	13.5 [0.53]	42.0 [1.63]
SV2H-2F0N	PDF	219.9 [8.66]	166.2 [6.54]	566.4 [22.30]	398.0 [15.67]	13.5 [0.53]	55.0 [2.17]
SV2H-2F0B	PDF	219.9 [8.66]	166.2 [6.54]	629.4 [24.78]	461.0 [18.15]	13.5 [0.53]	55.0 [2.17]



NOTE: Motor cables are approximately 304mm (12") in length.



For additional dimensions, see the AutomationDirect website or click on the drawing links.

460V Servo motor dimensions

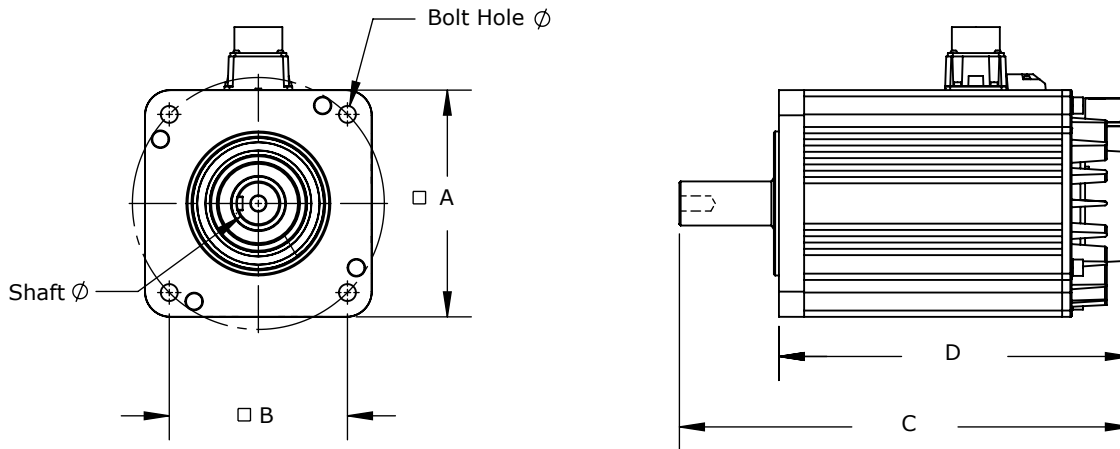

SureServo2 460V Motor Dimensions

Model	Drawing Link	A mm [inches]	B mm [inches]	C mm [inches]	D mm [inches]	Bolt Hole Ø mm [inches]	Shaft Ø mm [inches]
SV2L-404N	PDF	60.0 [2.36]	49.5 [1.95]	136.0 [5.35]	106.0 [4.17]	5.5 [0.22]	14.0 [0.55]
SV2L-404B	PDF	60.0 [2.36]	49.5 [1.95]	169.7 [6.68]	139.7 [5.50]	5.5 [0.22]	14.0 [0.55]
SV2L-407N	PDF	80.0 [3.15]	63.6 [2.51]	155.8 [6.13]	115.8 [4.56]	6.6 [0.26]	19.0 [0.75]
SV2L-407B	PDF	80.0 [3.15]	63.6 [2.51]	193.2 [7.61]	153.2 [6.03]	6.6 [0.26]	19.0 [0.75]
SV2L-410N	PDF	100.0 [3.94]	81.3 [3.20]	198.2 [7.81]	153.2 [6.03]	9.0 [0.35]	22.0 [0.87]
SV2L-410B	PDF	100.0 [3.94]	81.3 [3.20]	237.5 [9.35]	192.5 [7.58]	9.0 [0.35]	22.0 [0.87]
SV2L-415N	PDF	130.0 [5.12]	102.5 [4.04]	222.5 [8.76]	167.5 [6.59]	9.0 [0.35]	22.0 [0.87]
SV2L-415B	PDF	130.0 [5.12]	102.5 [4.04]	257.0 [10.12]	202.0 [7.95]	9.0 [0.35]	22.0 [0.87]
SV2L-420N	PDF	130.0 [5.12]	102.5 [4.04]	242.5 [9.55]	187.5 [7.38]	9.0 [0.35]	22.0 [0.87]
SV2L-420B	PDF	130.0 [5.12]	102.5 [4.04]	271.0 [10.67]	216.0 [8.50]	9.0 [0.35]	22.0 [0.87]
SV2M-410N	PDF	130.0 [5.12]	102.5 [4.04]	202.5 [7.97]	147.5 [5.81]	9.0 [0.35]	22.0 [0.87]
SV2M-410B	PDF	130.0 [5.12]	102.5 [4.04]	238.5 [9.39]	183.5 [7.22]	9.0 [0.35]	22.0 [0.87]
SV2H-430N	PDF	180.0 [7.09]	141.4 [5.57]	280.8 [11.06]	201.8 [7.94]	13.5 [0.53]	35.0 [1.38]
SV2H-430B	PDF	180.0 [7.09]	141.4 [5.57]	314.0 [12.36]	235.0 [9.25]	13.5 [0.53]	35.0 [1.38]
SV2H-445N	PDF	180.0 [7.09]	141.4 [5.57]	314.0 [12.36]	235.0 [9.25]	13.5 [0.53]	35.0 [1.38]
SV2H-445B	PDF	180.0 [7.09]	141.4 [5.57]	358.0 [14.09]	279.0 [10.98]	13.5 [0.53]	35.0 [1.38]
SV2H-455N	PDF	180.0 [7.09]	141.4 [5.57]	392.4 [15.45]	279.4 [11.00]	13.5 [0.53]	42.0 [1.65]
SV2H-455B	PDF	180.0 [7.09]	141.4 [5.57]	424.4 [16.71]	311.4 [12.26]	13.5 [0.53]	42.0 [1.65]
SV2H-475N	PDF	180.0 [7.09]	141.4 [5.57]	454.7 [17.90]	341.7 [13.45]	13.5 [0.53]	42.0 [1.65]
SV2H-475B	PDF	180.0 [7.09]	141.4 [5.57]	488.8 [19.24]	375.8 [14.80]	13.5 [0.53]	42.0 [1.65]
SV2H-4B0N	PDF	220.0 [8.66]	166.2 [6.54]	487.4 [19.19]	371.4 [14.62]	13.5 [0.53]	42.0 [1.65]
SV2H-4B0B	PDF	220.0 [8.66]	166.2 [6.54]	550.4 [21.67]	434.4 [17.10]	13.5 [0.53]	42.0 [1.65]
SV2H-4F0N	PDF	220.0 [8.66]	166.2 [6.54]	566.4 [22.30]	450.4 [17.73]	13.5 [0.53]	55.0 [2.17]
SV2H-4F0B	PDF	220.0 [8.66]	166.2 [6.54]	629.4 [24.78]	513.4 [20.21]	13.5 [0.53]	55.0 [2.17]



NOTE: Motor cables are approximately 304mm (12") in length.



For additional dimensions, see the AutomationDirect website or click on the drawing links.



AC Servo System Accessories

Accessories

CN1 Accessories

The terminal block module and direct mount feedthrough module allow for I/O connections to a SureServo2 drive.

Option 1:

Select an SV2-CN1-CBL50 cable (3 lengths available) and the DIN rail mount SV2-CN1-RTB50 Remote Terminal Block for access to all 50 of the drive's digital and analog I/O signals.

Option 2:

Select the SV2-CN1-LTB20 Local Terminal Block. The LTB20 can be used in many applications and allows connection to the most frequently-used I/O: High speed line driver pulse inputs (Pulse and Direction, AB Quad, etc.), (5) Digital Inputs, (4) Digital Outputs, and the Z-pulse open collector output.

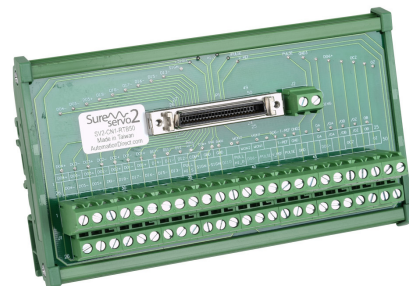

SV2-CN1-RTB50

Part Number	Price	Description	Cable Length	Drawing	Compatible Drives
<u>SV2-CN1-RTB50</u>	\$58.00	SureServo2 feedthrough module, 50-pole, DIN rail mount	-	<u>PDF</u>	All
<u>SV2-CN1-CBL50</u>	\$71.00	SureServo2 CN1 I/O control cable with mating connectors	0.5 m	-	
<u>SV2-CN1-CBL50-1</u>	\$75.00		1m		
<u>SV2-CN1-CBL50-2</u>	\$79.00		2m		
<u>SV2-CN1-LTB20</u>	\$43.00	SureServo2 feedthrough module, 20-pole, direct mount	-	<u>PDF</u>	



SV2-CN1-LTB20

Communication Modules

SureServo2 drives can also make use of optional communication cards. Both EtherNet/IP and Modbus TCP cards are available. Field upgradeable firmware ensures that the cards can always be kept current.

ModBus TCP

The SV2-CM-MODTCP Modbus TCP card allows the same access to all the drive parameters as the native serial Modbus (RS485).

EtherNet/IP

The SV2-CM-ENETIP Ethernet/IP card allows both Explicit and Implicit (I/O) Messaging. The SureServo2 Pro software allows you to easily generate (with pull-down menus) an EDS file for import into your PLC that contains exactly what you want in your Implicit Message.



SV2-CM-ENETIP
or
SV2-CM-MODTCP

Part Number	Price	Description	Drawing	Compatible Drives
<u>SV2-CM-ENETIP</u>	\$107.00	SureServo2 communication module, EtherNet/IP, 1 port, (1) Ethernet (RJ45) port.	<u>PDF</u>	All SureServo2 drives
<u>SV2-CM-MODTCP</u>	\$97.00	SureServo2 communication module, Modbus TCP, 1 port, (1) Ethernet (RJ45) port.	<u>PDF</u>	



AC Servo System Accessories

Accessories, continued

Motor Cables

Use the table to the right to select the correct SV2 motor cables (power, encoder, and brake) for your SureServo2 motor. Note that the largest frame brakemotors require a separate brake cable: 230V motors 5.5–15 kW and 460V motors 11kW–15kW. For smaller brakemotors, the brake wiring is incorporated into the motor power cable.

First find the motor part number in the left column, then reference the required cable part series under the Power, Encoder, and Brake columns. The first two "x" digits in the part numbers below are placeholders to represent length in meters while the 3rd "x" denotes flex (F) or non-flex (N) cabling. Brake vs non-brake cables are represented by a "B" or "N" at the end of the part number. For example, a 20m non-flex non-brake cable would end in 20NN, while a 3m flex-rated brake motor cable would end in 03FB. Note that SV2H series motors (5.5 kW and greater) use a separate cable to power the brake, so use an "N" cable for motor power. Also, if you use a flex-rated power cable (F series) you should use flex-rated encoder and brake power cables. The flex cables may not feel more flexible when compared side-by-side with the non-flex versions, but they are constructed with finer strands of wire and are designed to withstand millions of flex cycles (continuous flexing) without suffering from "cable corkscrew".

Specs and prices for the various cable options in each series can be found in the tables on the following pages.

Example:

You are purchasing an SV2L-201B brake motor and want 10m flex-rated cabling. What cables do you need? The abbreviated motor chart below shows that the SV2L-201B brake motor needs a PB18 series power cable and an E122 series encoder cable. Brake power is supplied through the power cable. The cable charts on subsequent pages enumerate all the various options and show that a 10m, flex, E122 series encoder cable is SV2C-E122-10FN and that a 10m, flex, PB series power cable is SV2C-PB18-10FB.

SureServo2® Motor		Power Cable	Encoder Cable	Brake Cable
230V	460V			
SV2L-201N SV2L-202N SV2L-204N SV2L-207N	SV2L-404N SV2L-407N	SV2C-PA18-xxxN	SV2C-E122-xxxN	n/a
SV2L-201B SV2L-202B SV2L-204B SV2L-207B	SV2L-404B SV2L-407B	SV2C-PB18-xxxB		
SV2L-210N	SV2L-410N SV2M-410N SV2L-415N SV2L-420N	SV2C-PC16-xxxN		
SV2L-210B	SV2L-410B SV2M-410B SV2L-415B SV2L-420B	SV2C-PC16-xxxB		
SV2M-210N SV2M-215N	–	SV2C-PC12-xxxN		
SV2M-210B SV2M-215B	–	SV2C-PC12-xxxB		
SV2M-220N SV2M-230N	SV2H-430N	SV2C-PD12-xxxN		
SV2M-220B SV2M-230B	SV2H-430B	SV2C-PD12-xxxB		
SV2H-245N	SV2H-445N SV2H-455N SV2H-475N	SV2C-PD08-xxxN	SV2C-E222-xxxN	
SV2H-245B	SV2H-445B SV2H-455B SV2H-475B	SV2C-PD08-xxxB		
SV2H-255N SV2H-275N SV2H-2B0N	–	SV2C-PF06-xxxN		
SV2H-255B SV2H-275B SV2H-2B0B	–	SV2C-PF06-xxxN		
SV2H-2F0N	–	SV2C-PF04-xxxN	n/a	
SV2H-2F0B	–	SV2C-PF04-xxxN	SV2C-B120-xxxB	
–	SV2H-4B0N SV2H-4F0N	SV2C-PF08-xxxN	n/a	
–	SV2H-4B0B SV2H-4F0B	SV2C-PF08-xxxN	SV2C-B120-xxxB	



Power Cables

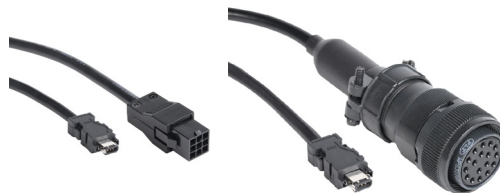

Encoder Cables



Separate Brake Cable
(for large frame motors (see table))



AC Servo System Accessories

Accessories, continued

SV2C-E122 Series Encoder Cables

Part Number	Price	Flex Rated	Length	Gauge	Drawing	Connector	Compatible Motors
SV2C-E122-03NN	\$60.00	N	3m	22	PDF	SV2C-E1-CON	SV2L-201x SV2L-202x SV2L-204x SV2L-207x SV2L-404x SV2L-407x
SV2C-E122-05NN	\$82.00		5m		PDF		
SV2C-E122-10NN	\$130.00		10m		PDF		
SV2C-E122-20NN	\$213.00		20m		PDF		
SV2C-E122-03FN	\$77.00	Y	3m		PDF		
SV2C-E122-05FN	\$109.00		5m		PDF		
SV2C-E122-10FN	\$182.00		10m		PDF		
SV2C-E122-20FN	\$316.00		20m		PDF		

SV2C-E222 Series Encoder Cables

Part Number	Price	Flex Rated	Length	Gauge	Drawing	Connector	Compatible Motors	
SV2C-E222-03NN	\$130.00	N	3m	22	PDF	SV2C-E2-CON	SV2L-210x	SV2L-410x
SV2C-E222-05NN	\$213.00		5m		PDF		SV2M-210x	SV2M-410x
SV2C-E222-10NN	\$265.00		10m		PDF		SV2M-215x	SV2L-415x
SV2C-E222-20NN	\$350.00		20m		PDF		SV2M-220x	SV2L-420x
SV2C-E222-03FN	\$168.00	Y	3m		PDF		SV2M-230x	SV2H-430x
SV2C-E222-05FN	\$206.00		5m		PDF		SV2H-245x	SV2H-445x
SV2C-E222-10FN	\$317.00		10m		PDF		SV2H-255x	SV2H-455x
SV2C-E222-20FN	\$453.00		20m		PDF		SV2H-275X	SV2H-475X
							SV2H-2B0x	SV2H-4B0x
							SV2H-2F0x	SV2H-4F0x

SV2C-PA18 Series Power Cables

Part Number	Price	Flex Rated	Length	Gauge	Drawing	Connector	Compatible Motors
SV2C-PA18-03NN	\$41.00	N	3m	18	PDF	SV2C-PA-CON	SV2L-201N SV2L-202N SV2L-204N SV2L-207N SV2L-404N SV2L-407N
SV2C-PA18-05NN	\$54.00		5m		PDF		
SV2C-PA18-10NN	\$80.00		10m		PDF		
SV2C-PA18-20NN	\$128.00		20m		PDF		
SV2C-PA18-03FN	\$57.00	Y	3m		PDF		
SV2C-PA18-05FN	\$77.00		5m		PDF		
SV2C-PA18-10FN	\$124.00		10m		PDF		
SV2C-PA18-20FN	\$212.00		20m		PDF		



AC Servo System Accessories

Accessories, continued

SV2C-PB18 Series Power Cables

Part Number	Price	Flex Rated	Length	Gauge	Drawing	Connector	Compatible Motors
SV2C-PB18-03NB	\$48.00	N	3m	18	PDF	SV2C-PB-CON	SV2L-201B SV2L-202B SV2L-204B SV2L-207B SV2L-404B SV2L-407B
SV2C-PB18-05NB	\$63.00		5m		PDF		
SV2C-PB18-10NB	\$100.00		10m		PDF		
SV2C-PB18-20NB	\$163.00		20m		PDF		
SV2C-PB18-03FB	\$72.00	Y	3m		PDF		
SV2C-PB18-05FB	\$105.00		5m		PDF		
SV2C-PB18-10FB	\$176.00		10m		PDF		
SV2C-PB18-20FB	\$313.00		20m		PDF		

SV2C-PC16 Series Power Cables

Part Number	Price	Flex Rated	Length	Gauge	Drawing	Connector	Compatible Motors
SV2C-PC16-03NN	\$140.00	N	3m	16	PDF	SV2C-PC-CON	SV2L-210N SV2L-410N SV2M-410N SV2L-415N SV2L-420N
SV2C-PC16-05NN	\$166.00		5m		PDF		
SV2C-PC16-10NN	\$219.00		10m		PDF		
SV2C-PC16-20NN	\$318.00		20m		PDF		
SV2C-PC16-03FN	\$154.00	Y	3m		PDF		
SV2C-PC16-05FN	\$186.00		5m		PDF		
SV2C-PC16-10FN	\$261.00		10m		PDF		
SV2C-PC16-20FN	\$401.00		20m		PDF		
SV2C-PC16-03NB	\$164.00	N	3m	16	PDF	SV2C-PC-CON	SV2L-210B SV2L-410B SV2M-410B SV2L-415B SV2L-420B
SV2C-PC16-05NB	\$198.00		5m		PDF		
SV2C-PC16-10NB	\$274.00		10m		PDF		
SV2C-PC16-20NB	\$415.00		20m		PDF		
SV2C-PC16-03FB	\$184.00	Y	3m		PDF		
SV2C-PC16-05FB	\$230.00		5m		PDF		
SV2C-PC16-10FB	\$335.00		10m		PDF		
SV2C-PC16-20FB	\$537.00		20m		PDF		



AC Servo System Accessories

Accessories, continued

SV2C-PC12 Series Power Cables

Part Number	Price	Flex Rated	Length	Gauge	Drawing	Connector	Compatible Motors
SV2C-PC12-03NN	\$192.00	N	3m	12	PDF	SV2C-PC-CON	SV2M-210N SV2M-215N
SV2C-PC12-05NN	\$251.00		5m		PDF		
SV2C-PC12-10NN	\$391.00		10m		PDF		
SV2C-PC12-20NN	\$659.00		20m		PDF		
SV2C-PC12-03FN	\$210.00	Y	3m		PDF		
SV2C-PC12-05FN	\$279.00		5m		PDF		
SV2C-PC12-10FN	\$443.00		10m		PDF		
SV2C-PC12-20FN	\$760.00		20m		PDF		
SV2C-PC12-03NB	\$213.00	N	3m	12	PDF		SV2M-210B SV2M-215B
SV2C-PC12-05NB	\$280.00		5m		PDF		
SV2C-PC12-10NB	\$442.00		10m		PDF		
SV2C-PC12-20NB	\$752.00		20m		PDF		
SV2C-PC12-03FB	\$235.00	Y	3m		PDF		
SV2C-PC12-05FB	\$316.00		5m		PDF		
SV2C-PC12-10FB	\$513.00		10m		PDF		
SV2C-PC12-20FB	\$892.00		20m		PDF		

SV2C-PD12 Series Power Cables

Part Number	Price	Flex Rated	Length	Gauge	Drawing	Connector	Compatible Motors
SV2C-PD12-03NN	\$175.00	N	3m	12	PDF	SV2C-PD-CON	SV2M-220N SV2M-230N SV2H-430N
SV2C-PD12-05NN	\$223.00		5m		PDF		
SV2C-PD12-10NN	\$342.00		10m		PDF		
SV2C-PD12-20NN	\$570.00		20m		PDF		
SV2C-PD12-03FN	\$188.00	Y	3m		PDF		
SV2C-PD12-05FN	\$246.00		5m		PDF		
SV2C-PD12-10FN	\$386.00		10m		PDF		
SV2C-PD12-20FN	\$655.00		20m		PDF		
SV2C-PD12-03NB	\$194.00	N	3m	12	PDF		SV2M-220B SV2M-230B SV2H-430B
SV2C-PD12-05NB	\$251.00		5m		PDF		
SV2C-PD12-10NB	\$386.00		10m		PDF		
SV2C-PD12-20NB	\$649.00		20m		PDF		
SV2C-PD12-03FB	\$212.00	Y	3m		PDF		
SV2C-PD12-05FB	\$281.00		5m		PDF		
SV2C-PD12-10FB	\$447.00		10m		PDF		
SV2C-PD12-20FB	\$768.00		20m		PDF		



AC Servo System Accessories

Accessories, continued

SV2C-PD08 Series Power Cables

Part Number	Price	Flex Rated	Length	Gauge	Drawing	Connector	Compatible Motors	
SV2C-PD08-03NN	\$238.00	N	3m	8	PDF	SV2C-PD-CON	SV2H-245N SV2H-445N SV2H-455N SV2H-475N	
SV2C-PD08-05NN	\$325.00		5m		PDF			
SV2C-PD08-10NN	\$544.00		10m		PDF			
SV2C-PD08-20NN	\$970.00		20m		PDF			
SV2C-PD08-03FN	\$258.00	Y	3m		PDF			
SV2C-PD08-05FN	\$360.00		5m		PDF			
SV2C-PD08-10FN	\$612.00		10m		PDF			
SV2C-PD08-20FN	\$1,108.00		20m		PDF			
SV2C-PD08-03NB	\$231.00	N	3m	8	PDF		SV2C-PD-CON	SV2H-245B SV2H-445B SV2H-455B SV2H-475B
SV2C-PD08-05NB	\$326.00		5m		PDF			
SV2C-PD08-10NB	\$559.00		10m		PDF			
SV2C-PD08-20NB	\$1,009.00		20m		PDF			
SV2C-PD08-03FB	\$272.00	Y	3m		PDF			
SV2C-PD08-05FB	\$383.00		5m		PDF			
SV2C-PD08-10FB	\$659.00		10m		PDF			
SV2C-PD08-20FB	\$1,192.00		20m		PDF			

SV2C-PF08 Series Power Cables

Part Number	Price	Flex Rated	Length	Gauge	Drawing	Connector	Compatible Motors
SV2C-PF08-03NN	\$241.00	N	3m	8	PDF	SV2C-PF-CON	SV2H-4B0N SV2H-4B0B SV2H-4F0N SV2H-4F0B
SV2C-PF08-05NN	\$297.00		5m		PDF		
SV2C-PF08-10NN	\$433.00		10m		PDF		
SV2C-PF08-20NN	\$750.00		20m		PDF		
SV2C-PF08-03FN	\$305.00	Y	3m		PDF		
SV2C-PF08-05FN	\$401.00		5m		PDF		
SV2C-PF08-10FN	\$633.00		10m		PDF		
SV2C-PF08-20FN	\$1,148.00		20m		PDF		

SV2C-PF06 Series Power Cables

Part Number	Price	Flex Rated	Length	Gauge	Drawing	Connector	Compatible Motors
SV2C-PF06-03NN	\$323.00	N	3m	6	PDF	SV2C-PF-CON	SV2H-255N SV2H-255B SV2H-275N SV2H-275B SV2H-2B0N SV2H-2B0B
SV2C-PF06-05NN	\$478.00		5m		PDF		
SV2C-PF06-10NN	\$833.00		10m		PDF		
SV2C-PF06-20NN	\$1,507.00		20m		PDF		
SV2C-PF06-03FN	\$376.00	Y	3m		PDF		
SV2C-PF06-05FN	\$528.00		5m		PDF		
SV2C-PF06-10FN	\$913.00		10m		PDF		
SV2C-PF06-20FN	\$1,660.00		20m		PDF		



AC Servo System Accessories

Accessories, continued

SV2C-PF04 Series Power Cables

Part Number	Price	Flex Rated	Length	Gauge	Drawing	Connector	Compatible Motors
SV2C-PF04-03NN	\$382.00	N	3m	4	PDF	SV2C-PF-CON	SV2H-2F0N SV2H-2F0B
SV2C-PF04-05NN	\$539.00		5m		PDF		
SV2C-PF04-10NN	\$909.00		10m		PDF		
SV2C-PF04-20NN	\$1,652.00		20m		PDF		
SV2C-PF04-03FN	\$434.00	Y	3m		PDF		
SV2C-PF04-05FN	\$612.00		5m		PDF		
SV2C-PF04-10FN	\$1,064.00		10m		PDF		
SV2C-PF04-20FN	\$1,944.00		20m		PDF		

SV2C-B120 Series Brake Cables

Part Number	Price	Flex Rated	Length	Gauge	Drawing	Connector	Compatible Motors
SV2C-B120-03NB	\$88.00	N	3m	20	PDF	SV2C-B1-CON	SV2H-255B SV2H-275B SV2H-2B0B SV2H-2F0B SV2H-4B0B SV2H-4F0B
SV2C-B120-05NB	\$102.00		5m		PDF		
SV2C-B120-10NB	\$128.00		10m		PDF		
SV2C-B120-20NB	\$172.00		20m		PDF		
SV2C-B120-03FB	\$95.00	Y	3m		PDF		
SV2C-B120-05FB	\$112.00		5m		PDF		
SV2C-B120-10FB	\$149.00		10m		PDF		
SV2C-B120-20FB	\$214.00		20m		PDF		

Accessories, continued

External Encoder CN5 Cables

CN5 secondary encoder cables can be used to connect an external secondary encoder to a SureServo2 drive. The CN5 uses a wire not present in standard VGA cables - you must use one of these cables, standard HD15 VGA cables will not work.

Part Number	Price	Description	Length	Drawing	Compatible Drives
<u>ZL-HD15M-CBL-2P</u>	\$19.00	ZIPLink communication cable, 15-pin D-sub HD15 male to pigtail, shielded, twisted pair.	2m	<u>PDF</u>	All SV2 drives
<u>ZL-HD15M-CBL-DB15F*</u>	\$20.50	ZIPLink communication cable, 15-pin female D-sub to 15-pin D-sub HD15 male, shielded, twisted pair.	2m	<u>PDF</u>	

* ZL-RTB-DB15 is required to use the ZL-HD15M-CBL-DB15F cable

Pin Number	Color	Signal	Function
1	Black/White	Opt_/Z	/Z phase input
2	Blue/White	Opt_/B	/B phase input
3	Blue	Opt_B	B phase input
4	Green	Opt_A	A phase input
5	Green/White	Opt_/A	/A phase input
6	Yellow Yellow/Black	GND	Encoder grounding
7	Red/White	GND	Encoder grounding
8	Red	+5V	Encoder power
9	Black	Opt_Z	Z phase input
10	Orange	Reserved	Reserved
11	Orange/White	Reserved	Reserved
12	Brown	Reserved	Reserved
13	Brown/White	Reserved	Reserved
14	Purple	Reserved	Reserved
15	Purple/White	Reserved	Reserved

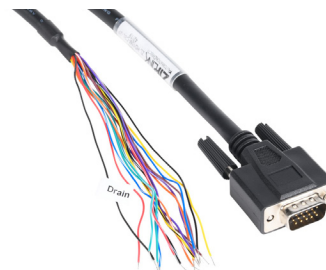

ZL-HD15M-CBL-2P



ZL-RTB-DB15



ZL-HD15M-CBL-DB15F



SV2-BBOX-CBL

Battery Box

An optional external battery can be used to power SureServo2 encoders. The battery allows the use of Absolute Encoder Mode. This mode will keep track of the motor actual position (regardless of number of turns) even if control power is removed from the drive.

SV2-BBOX-1 attaches to the encoder cable. There is a small connector protruding from each encoder cable several inches from the drive-end connector. This connector plugs into the SV2-BBOX-1.

SV2-BBOX-CBL is not required for most applications. Use this cable to extend the length from the encoder cable's connector to the BBOX. This is used if you do not want the BBOX clamped onto the encoder cable right under the drive.

Part Number	Price	Description	Length	Drawing	Compatible Drives
<u>SV2-BBOX-1</u>	\$22.50	SureServo2 encoder single battery box, for use with all SureServo2 drives. (1) AA ER14505 lithium battery included.	-	<u>PDF</u>	All SV2 drives
<u>SV2-BBOX-CBL</u>	\$3.00	SureServo2 battery box cable, mating connectors, 7.8 in/200mm cable length. For use with SureServo2 encoder battery box.	200mm	<u>PDF</u>	



SV2-BBOX-1



AC Servo System Accessories

Accessories, continued

Serial Comms Connectors

Available serial comms connectors consist of an RS-485 splitter and an RS-485 terminating resistor. These connectors (and the drive's CN3) all use RJ45 connectors.

With these two connectors, you can easily create a multi-drop RS485 connection with minimal manual wiring. For multi-drop systems, use one SV2-CN3-CON-2 per drive. Connect each drive with a standard RJ45 (Ethernet patch) cable. On the last drive in the daisy-chain, plug in an SV2-CN3-TR2 to terminate the network. On the first drive, either strip one end of a patch cable to wire into your controller/PLC or plug into a ZL-RTB-RJ45 breakout board for easy wiring to your controller/PLC.

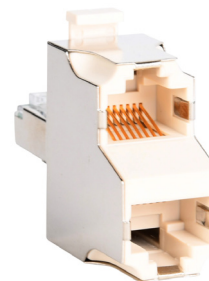

SV2-CN3-CON-2



SV2-CN3-TR2

Part Number	Price	Description	Drawing	Compatible Drives
SV2-CN3-CON-2	\$11.50	SureServo2 splitter, (2) RS-485 (RJ45) to (1) RS-485 (RJ45)	PDF	All SureServo2 Drives
SV2-CN3-TR2	\$5.25	Terminating resistor, 120 ohm, RJ45 8P8C male.	PDF	

Toroid

A toroid (ferrite ring) is available for use with all SureServo2 drives to reduce radiated noise. See the user manual for application information for the SV2-TOR1.



SV2-TOR1

Part Number	Price	Description	Drawing	Compatible Drives
SV2-TOR1	\$13.50	Toroid ring for EMI/RFI filtering (2 per pack)	PDF	All SureServo2 Drives

Cable Connectors

Use the cable connectors below to build your own motor power, brake, or encoder cable.

Part Number	Price	Description	Drawing	Compatible With
SV2C-PA-CON	\$11.50	SureServo2 motor power connector	PDF	750W or smaller SureServo2 motors w/o brake
SV2C-PB-CON	\$13.50		PDF	750W or smaller SureServo2 motors w/brake
SV2C-PC-CON	\$40.00		PDF	All 1 and 1.5 kW and 460V series 2kW SureServo2 motors
SV2C-PD-CON	\$47.00		PDF	230V series 2 to 4.5 kW and 460V series 3 to 7.5 kW SureServo2 motors
SV2C-PF-CON	\$69.00		PDF	230V series 5.5 to 15kW and 460V series 11 and 15kW SureServo2 motors
SV2C-E1-CON	\$10.00	SureServo2 motor encoder connector	PDF	750W or smaller SureServo2 motors
SV2C-E2-CON	\$37.00		PDF	1kW and larger SureServo2 motors
SV2C-E3-CON	\$10.00	CN2 encoder cable (connection to drive)	PDF	All SureServo2 drives
SV2C-B1-CON	\$32.00	SureServo2 motor brake connector	PDF	230V series 5.5 to 15kW and 460V series 11 and 15kW SureServo2 motors with brake

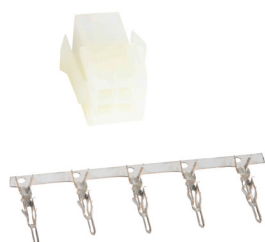

SV2C-PA-CON



SV2C-PF-CON



SV2C-E1-CON

Accessories, continued

Replacement Connectors

The following replacement connectors can be purchased for use with SureServo2 drives. SV2-CN1-CON and SV2-CN10-STO are standalone connectors, while SV2-CON-KIT is a set of connectors.

Part Number	Price	Description	Drawing	Compatible With
<u>SV2-CN1-CON</u>	\$17.50	Optional 50-pin CN1 I/O connector (solder)	-	All SureServo2 drives
<u>SV2-CON-KIT</u>	\$21.50	SureServo2 replacement connector kit, contains: (1) SV2-CN10-STO connector (2) AC power connectors (1) Power resistor connector (1) Motor power connector (2) Wire insert tools	-	Up to 1.5 kW 230V SureServo2 drives (460V drives use integrated terminals)
<u>SV2-CN10-STO</u>	\$10.00	Replacement SureServo2 STO connector	<u>PDF</u>	All SureServo2 drives



SV2-CON-KIT



SV2-CN10-STO



SV2-CN1-CON

Replacement Drive Fans

The following replacement fans can be purchased for use with SureServo2 drives. Each fan can be used to replace the fan on a specific 230 and 460 V drive. Please see the table below to find the correct part.

Part Number	Price	Description
<u>SV2-FAN-1</u>	\$15.00	SureServo2 main cooling fan, replacement, 40 x 40 x 15mm, 12 VDC. For use with SureServo2 SV2A-2075 and SV2A-2150 drives. Electrical connector included.
<u>SV2-FAN-2</u>	\$14.00	SureServo2 main cooling fan, replacement, 50 x 50 x 20mm, 12 VDC. For use with SureServo2 SV2A-2200 and SV2A-2300 drives. Electrical connector included.
<u>SV2-FAN-3</u>	\$23.00	SureServo2 main cooling fan, replacement, 50 x 50 x 20mm, 12 VDC. For use with SureServo2 SV2A-4040, SV2A-4075 and SV2A-4150 drives. Electrical connector included.
<u>SV2-FAN-4</u>	\$24.00	SureServo2 main cooling fan, replacement, 60 x 60 x 25mm, 12 VDC. For use with SureServo2 SV2A-2550, SV2A-4300 and SV2A-4550 drives. Electrical connector included.
<u>SV2-FAN-5</u>	\$19.00	SureServo2 main cooling fan, replacement, 60 x 60 x 20mm, 12 VDC. For use with SureServo2 SV2A-2550, SV2A-4200 and SV2A-4550 drives. Electrical connector included.
<u>SV2-FAN-6</u>	\$27.00	SureServo2 main cooling fan, replacement, 70 x 70 x 25mm, 12 VDC. For use with SureServo2 SV2A-2750 and SV2A-4750 drives. Electrical connector included.
<u>SV2-FAN-7</u>	\$49.00	SureServo2 main cooling fan, replacement, 92 x 92 x 38mm, 24 VDC. For use with SureServo2 SV2A-2F00 drive. Electrical connector included.
<u>SV2-FAN-8</u>	\$38.00	SureServo2 main cooling fan, replacement, 92 x 92 x 38mm, 12 VDC. For use with SureServo2 SV2A-4F00 drive. Electrical connector included.



SV2-FAN-1



SV2-FAN-8

AC Servo Systems

3 Standard Drives ... 8 Standard Motors ... 100W to 3kW
... over 50 gearboxes (both inline and right angle) with four ratios

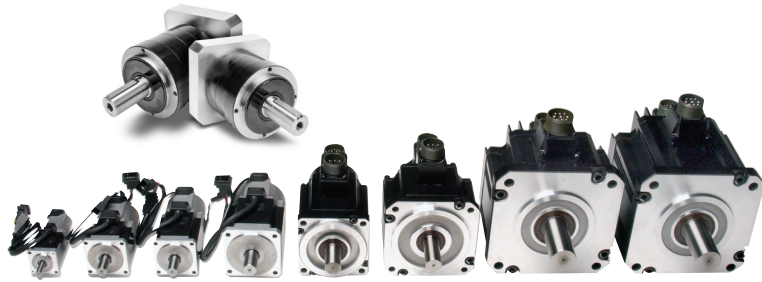

Drive features

- Main Power and Control Power Inputs
 - Main Power: 230 VAC 1-phase/3-phase (2kW and 3kW systems are 3-phase only)
 - Control Power: 230 VAC Single Phase; 50/60 Hz
- Fully digital with up to 450 Hz velocity loop response
- Easy setup and diagnostics with built-in keypad/display or the SureServo Pro PC-based software
- Five-in-one command options include:
 - $\pm 10V$ torque or velocity command
 - Pulse train or master encoder position command (accepts line driver or open collector) with electronic gearing
 - Built-in indexer for position control using 8 preset positions and/or position setpoint with serial Modbus
- Tuning aids include inertia estimation and easy tuning for up to 10 levels of response
- Optically isolated digital inputs (8) and outputs (5), analog outputs for monitor signals (2), and line driver output for encoder (with scalable resolution)

SureServo tuning technology

The SureServo drive closes the loop on current, velocity, and position (depending on control mode selection). Proportional gain, integral gain, feed forward compensation, command low pass filter, and a notch filter for resonance suppression are available. There are three tuning modes:

1. "Manual Mode" for user-defined adjustments
2. "Easy Mode" for default settings over a wide range of programmed inertia with 10 response levels
3. "Auto Mode" for automatic adjustment using an estimated (or measured) value of inertia

Motor features

- Low inertia models:
 - 100W, 200W, 400W, 750W and 1kW
 - Speeds up to 5,000 rpm.
- Medium inertia models:
 - 1kW, 2kW and 3kW
 - Speeds up to 3,000 rpm.
- Square flange mounting with metric dimensions:
 - 40, 60, 80, 100, 130 and 180 mm flanges
- Permanent magnet 3-phase synchronous motor
- Keyless drive shafts support clamp-on style coupling
- Integrated encoder with 2,500 (x4) pulses/revolution plus marker pulse (once per revolution)
- Optional 24 VDC spring-set holding brakes
- Standard hook-up cables for motor power/brake and encoder
- Standard DIN-rail mounted ZIPLink break-out kit for the drive's CN1 connector (with screw terminal connections)

SureServo built-in motion controller

While the SureServo drives can accept traditional commands from host controls, they can also provide their own internal motion control. For example, up to eight index moves can be pre-defined and stored in the drive and then selected and executed using up to three discrete inputs. The predefined index profiles can also be changed via serial communications. The motion can be incremental or absolute (homing routines are available in the drive) and acceleration can be linear or S-curve.

Multiple drives can be daisy-chained and addressed separately using the drive's serial port. This allows very simple yet powerful control of multi-axis processes that do not need precise path control but only precise starting and stopping points. Applications include press feeds, auger fillers, rotary tables, robots for pick and place, test or assembly operations, drilling, cutting, tapping, and similar applications using simple index moves for single or multi-axis motion.

SureServo Optional Holding Brake

Each SureServo motor can be ordered with an optional 24VDC spring-set holding brake that holds the motor in place when power is removed.

SureGear® Precision Gearboxes for Servo motors

Inertia balancing issue in your design?

The SureGear PGA series easily mates to SureServo motors. Everything you need to mount your SureServo motor is included!



- Four gear ratios available (5, 10, 15, 25:1)
- Mounting hardware included for attaching to SureServo motors
- Industry-standard mounting dimensions
- Thread-in mounting style
- Best-in-class backlash (5 arc-min)
- 5-year warranty

How to select and apply SureServo systems

The primary purpose of the AC servo system is to precisely control the motion of the load. The most fundamental considerations in selecting the servo system are "reflected" load inertia, servo system maximum speed requirement, servo system continuous torque requirement, and servo system peak torque requirement. In a retrofit application, select the largest torque SureServo system that most closely matches these

parameters for the system being replaced. In a new application, these parameters should be determined through calculation and/or measurement.

AutomationDirect has teamed with Copperhill Technologies to provide free servo-sizing software. "VisualSizer-SureServo" software will assist in determining the correct motor and drive for your application by calculating the reflected load inertia and required speed and torque based on the load configuration. "VisualSizer-SureServo" software can be downloaded from www.sureservo.com/downloads.htm.

Information for selecting SureServo systems is also included in Appendix B of the SureServo User Manual, which can be downloaded from the AutomationDirect.com website.

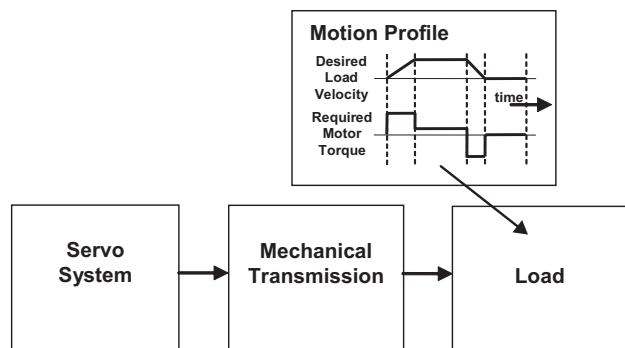

1. "Reflected" load inertia

The inertia of everything attached to the servo motor driveshaft needs to be considered and the total "reflected" inertia needs to be determined. This means that all elements of any mechanical transmission and load inertia need to be translated into an equivalent inertia as if attached directly to the motor driveshaft. The ratio of "reflected" load inertia to motor inertia needs to be carefully considered when selecting the servo system.

inertia as low as possible and ideally under 10:1. Systems with ratios as high as 200:1 can be implemented, but corresponding lower bandwidth or responsiveness must be accepted. The servo response including the attached load inertia is determined by the servo tuning. SureServo systems may be tuned manually, adaptively with measurement of the load inertia, or set with default tuning based on a programmed value of load inertia.

In general, applications that need high response or bandwidth will benefit from keeping the ratio of load inertia to motor

2. Torque and speed

With knowledge of the motion profile and any mechanical transmission between the motor and load, calculations can be made to determine the required servo motor continuous torque, peak torque, and maximum motor speed. The required amount of continuous torque must fall inside the continuous operating region of the system torque-speed curve (you can check the continuous torque at the average speed of the motion profile). The required amount of peak torque must also fall within the servo system's intermittent operating region of the system torque-speed curve (you need to check this value at the required maximum speed).

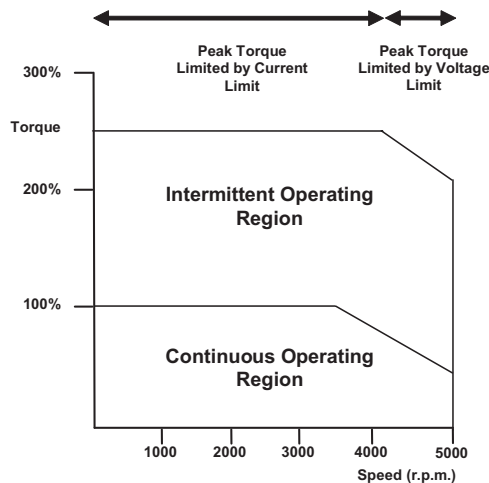

Application tip - coupling considerations

The SureServo motors have keyless shafts that are designed for use with clamp-on or compression style couplings. Couplings using keys and/or set screws should NOT be used with SureServo motors as they are likely to come loose or damage the motor shaft. "Servo-grade" clamp-on or compression style couplings are usually the best choice when you consider the stiffness, torque rating, and inertia. Higher

stiffness (lb-in/radian) is needed for better response but there is a trade-off between the stiffness and the added inertia of the coupling. Concerning the torque rating of the coupling, use a safety factor of 1.25 over the SureServo peak torque requirement of your application.

Coupling Suppliers: www.sureservo.com/couplingconsiderations.htm

Mechanical transmissions

Common mechanical transmissions include leadscrews, rack & pinion mechanisms, conveyors, gears, and timing belts. The use of leadscrew, rack & pinion, or conveyor are common

ways to translate the rotary motion of the servo motor into linear motion of the load. The use of a speed reducer such as a gearbox or timing belt can be very beneficial as follows:

1. Reduction of reflected load inertia

As a general rule, it is beneficial to keep the reflected load inertia as low as possible while using the full range of servo speed. SureServo systems can go up to 5,000 rpm for the low inertia motors and up to 3,000 rpm for the medium inertia motors.

Example: A gearbox reduces the required torque by a factor of the gear ratio, and reduces the reflected load inertia by a factor of the gear ratio squared. A 10:1 gearbox reduces output speed to 1/10, increases output torque 10 times, and decreases reflected inertia to 1/100.

However, when investigating the effect of different speed reduction ratios DO NOT forget to include the added inertia of couplings, gearbox, or timing belt pulleys. These added inertias can be significant, and can negate any inertia reduction due to the speed reduction.

2. Low speed and high torque applications

If the application requires low speed and high torque then it is common to introduce a speed reducer so that the servo system can operate over more of the available speed range. This could also have the added benefit of reducing the servo motor torque requirement which could allow you to use a smaller and lower cost servo system. Additional benefits are also possible with reduction in reflected inertia, increased number of motor encoder counts at the load, and increased ability to reject load disturbances due to mechanical advantage of the speed reducer.

3. Space limitations and motor orientation

SureServo motors can be mounted in any orientation, but the shaft seal should not be immersed in oil (open-frame gearbox, etc.). Reducers can possibly allow the use of a smaller motor or allow the motor to be repositioned. For example, some reducers would allow for in-line, right angle, or parallel mounting of the motor.

For more information, refer to the website listed below.

www.sureservo.com/mechanical_trans.htm

Ordering guide instructions

The following four pages are your ordering guide for the eight standard SureServo systems. Each of the eight standard systems has a torque-speed curve including the motor inertia for reference. This is the fundamental information that you need to select the servo drive and matching motor for your application.

Don't forget the cables and ZIPLink break-out board kit!

Included in the ordering guide are the available connection cables from the drive to motor in standard lengths from 10 to 60 feet. The break-out board kit includes a 0.5m (19 inch) cable for the CN1 I/O interface, and is listed for your convenience. We highly recommend all five items per system as a minimum. All cables are 100% factory tested to make your system installation as easy and quick as possible. See the Accessories section for regeneration resistors, AC line filters, fuses, contactors, and RF noise filters.



AC Servo System Configuration

SureServo series drives and motors part numbering system

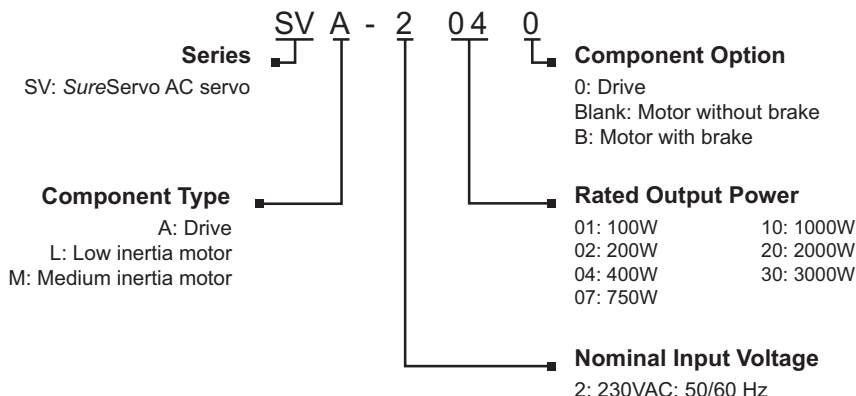

Here is what you will need to order a complete servo system:



NOTE: Unit can be programmed via keypad.
Optional programming software (free download) and optional programming cable available.

NOTE: If you need a gear box for your configuration, you can do it easily online:
<http://www.sureservo.com/gearbox-selector>



SureServo AC servo drive, motor, and cable combinations

Inertia & Power		Drive and Motor			Power Cables (from Drive to Motor)				Encoder Feedback Cables				Miscellaneous	
Inertia	Power	Servo Drive	Servo Motor without brake (note)	Servo Motor with brake (note)	10 ft	20 ft	30 ft	60 ft	10 ft	20 ft	30 ft	60 ft	ZIPLink I/O Interface	RS-422/485 Serial Communication Cable
Low inertia	100W	SVA-2040	SVL-201	SVL-201B	SVC-PFL-010	SVC-PFL-020	SVC-PFL-030	SVC-PFL-060	SVC-EFL-010	SVC-EFL-020	SVC-EFL-030	SVC-EFL-060	ZL-RTB50 and ZL-SVC-CBL50 or ZL-SVC-CBL50-1 or ZL-SVC-CBL50-2	SVC-MDCOM-CBL
	200W		SVL-202	SVL-202B										
	400W		SVL-204	SVL-204B										
	750W		SVL-207	SVL-207B										
	1000W		SVL-210	SVL-210B										
Medium inertia	1000W	SVA-2100	SVM-210	SVM-210B	SVC-PHM-010	SVC-PHM-020	SVC-PHM-030	SVC-PHM-060	SVC-EHH-010	SVC-EHH-020	SVC-EHH-030	SVC-EHH-060	ZL-SVC-CBL50 or ZL-SVC-CBL50-1 or ZL-SVC-CBL50-2	SVC-MDCOM-CBL
	2000W	SVA-2300	SVM-220	SVM-220B	SVC-PHH-010	SVC-PHH-020	SVC-PHH-030	SVC-PHH-060						
	3000W	SVM-230	SVM-230B											

Note: Each servo motor requires an encoder feedback cable and a power cable.
The motor power cable includes brake power wires for the optional motor brake.



AC Servo System Configuration

For all systems:

Order programming software & programming cable if needed. See pgs. [pageSRV-151](#) & [pageSRV-163](#).

100W Low Inertia System

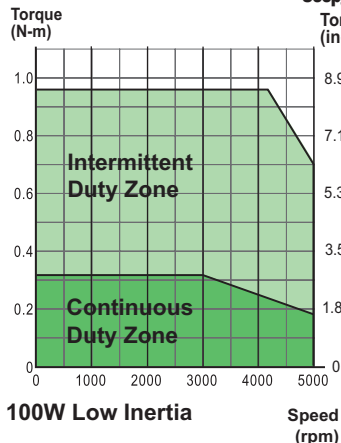

Servo Drive
SVA-2040 Retired

100W Low Inertia

Jm= Motor Inertia = 0.000027 lb-in-s² (0.000003 kg - m²)

SureServo Motor

2. **SVL-201** Retired
SVL-201B (w/brake) Retired

Motor Power Cable (1)

3. **SVC-PFL-010 (10')** \$51.00
SVC-PFL-020 (20') \$96.00
SVC-PFL-030 (30') \$121.00
SVC-PFL-060 (60') \$218.00

Motor Encoder Cable (1)

4. **SVC-EFL-010 (10')** Retired
SVC-EFL-020 (20') \$141.00
SVC-EFL-030 (30') \$165.00
SVC-EFL-060 (60') \$209.00

Z/PLink I/O Interface

5. **ZL-RTB50** \$74.00
and one cable below:
ZL-SVC-CBL50 (0.5m) \$48.50
ZL-SVC-CBL50-1 (1m) \$51.00
ZL-SVC-CBL50-2 (2m) \$58.00

200W Low Inertia System

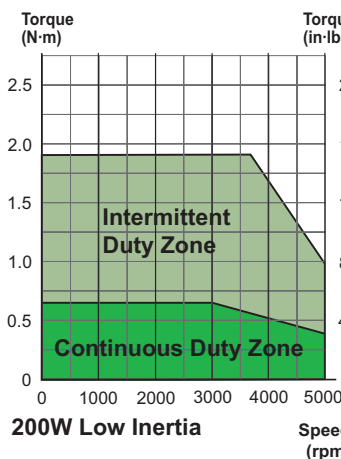

Servo Drive
SVA-2040 Retired

200W Low Inertia

Jm= Motor Inertia = 0.00016 lb-in-s² (0.000018 kg - m²)

SureServo Motor

2. **SVL-202** Retired
SVL-202B (w/brake) Retired

Motor Power Cable (1)

3. **SVC-PFL-010 (10')** \$51.00
SVC-PFL-020 (20') \$96.00
SVC-PFL-030 (30') \$121.00
SVC-PFL-060 (60') \$218.00

Motor Encoder Cable (1)

4. **SVC-EFL-010 (10')** Retired
SVC-EFL-020 (20') \$141.00
SVC-EFL-030 (30') \$165.00
SVC-EFL-060 (60') \$209.00

Z/PLink I/O Interface

5. **ZL-RTB50** \$74.00
and one cable below:
ZL-SVC-CBL50 (0.5m) \$48.50
ZL-SVC-CBL50-1 (1m) \$51.00
ZL-SVC-CBL50-2 (2m) \$58.00

400W Low Inertia System

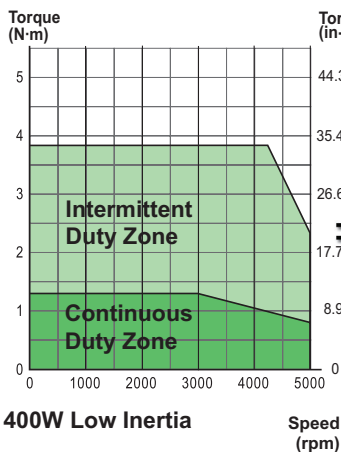

Servo Drive
SVA-2040 Retired

400W Low Inertia

Jm= Motor Inertia = 0.0003 lb-in-s² (0.000034 kg - m²)

SureServo Motor

2. **SVL-204** Retired
SVL-204B (w/brake) Retired

Motor Power Cable (1)

3. **SVC-PFL-010 (10')** \$51.00
SVC-PFL-020 (20') \$96.00
SVC-PFL-030 (30') \$121.00
SVC-PFL-060 (60') \$218.00

Motor Encoder Cable (1)

4. **SVC-EFL-010 (10')** Retired
SVC-EFL-020 (20') \$141.00
SVC-EFL-030 (30') \$165.00
SVC-EFL-060 (60') \$209.00

Z/PLink I/O Interface

5. **ZL-RTB50** \$74.00
and one cable below:
ZL-SVC-CBL50 (0.5m) \$48.50
ZL-SVC-CBL50-1 (1m) \$51.00
ZL-SVC-CBL50-2 (2m) \$58.00



AC Servo System Configuration

For all systems:

750W Low Inertia System

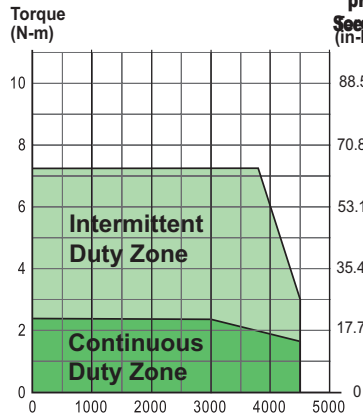

750W Low Inertia

Jm= Motor Inertia = .00096 lb-in-s² (0.000108 kg - m²)

Order programming software & programming cable if needed. See page SRV-151 & page SRV-163.



Servo Drive **SVA-2100** Retired

SureServo Motor



- 2. **SVL-207** Retired
- SVL-207B (w/brake)** Retired

Motor Power Cable (1)



- 3. **SVC-PFL-010 (10')** \$51.00
- SVC-PFL-020 (20')** \$96.00
- SVC-PFL-030 (30')** \$121.00
- SVC-PFL-060 (60')** \$218.00

Motor Encoder Cable (1)



- 4. **SVC-EFL-010 (10')** Retired
- SVC-EFL-020 (20')** \$141.00
- SVC-EFL-030 (30')** \$165.00
- SVC-EFL-060 (60')** \$209.00

ZIPLink I/O Interface



- 5. **ZL-RTB50** \$74.00
- and one cable below:
- ZL-SVC-CBL50 (0.5m)** \$48.50
- ZL-SVC-CBL50-1 (1m)** \$51.00
- ZL-SVC-CBL50-2 (2m)** \$58.00

1 kW Low Inertia System

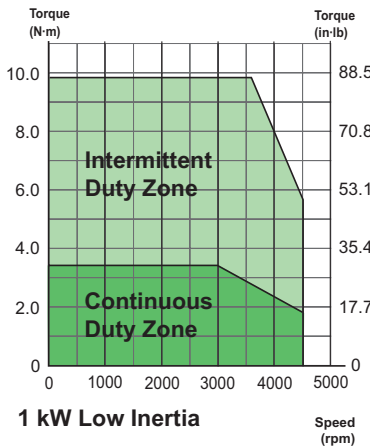

1 kW Low Inertia

Jm= Motor Inertia = .0023 lb-in-s² (0.00026 kg - m²)



Servo Drive **SVA-2100** Retired

SureServo Motor



- 2. **SVL-210** Retired
- SVL-210B (w/brake)** Retired

Motor Power Cable (1)



- 3. **SVC-PHM-010 (10')** \$160.00
- SVC-PHM-020 (20')** Retired
- SVC-PHM-030 (30')** \$290.00
- SVC-PHM-060 (60')** \$343.00

Motor Encoder Cable (1)



- 4. **SVC-EHH-010 (10')** \$153.00
- SVC-EHH-020 (20')** \$171.00
- SVC-EHH-030 (30')** Retired
- SVC-EHH-060 (60')** \$250.00

ZIPLink I/O Interface



- 5. **ZL-RTB50** \$74.00
- and one cable below:
- ZL-SVC-CBL50 (0.5m)** \$48.50
- ZL-SVC-CBL50-1 (1m)** \$51.00
- ZL-SVC-CBL50-2 (2m)** \$58.00

1 kW Medium Inertia System

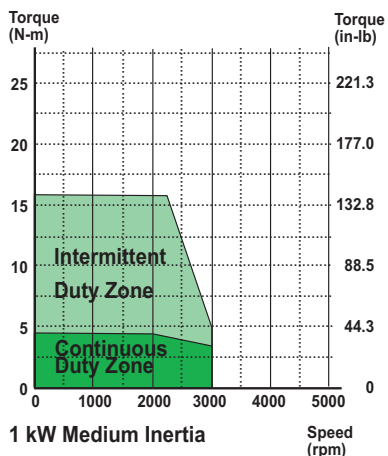

1 kW Medium Inertia

Jm= Motor Inertia = .0053 lb-in-s² (0.000598 kg - m²)



Servo Drive **SVA-2100** Retired

SureServo Motor



- 2. **SVM-210** Retired
- SVM-210B (w/brake)** Retired

Motor Power Cable (1)



- 3. **SVC-PHM-010 (10')** \$160.00
- SVC-PHM-020 (20')** Retired
- SVC-PHM-030 (30')** \$290.00
- SVC-PHM-060 (60')** \$343.00

Motor Encoder Cable (1)



- 4. **SVC-EHH-010 (10')** \$153.00
- SVC-EHH-020 (20')** \$171.00
- SVC-EHH-030 (30')** Retired
- SVC-EHH-060 (60')** \$250.00

ZIPLink I/O Interface



- 5. **ZL-RTB50** \$74.00
- and one cable below:
- ZL-SVC-CBL50 (0.5m)** \$48.50
- ZL-SVC-CBL50-1 (1m)** \$51.00
- ZL-SVC-CBL50-2 (2m)** \$58.00



AC Servo System Configuration

For all systems:

2 kW Medium Inertia System

Order programming software & programming cable if needed. See [pgs.pagetSRV-151](#) & [pagetSRV-163](#).

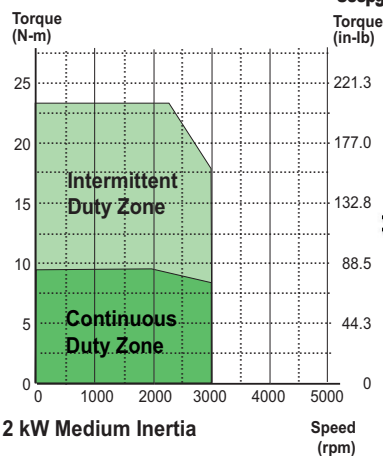

2 kW Medium Inertia

$J_m = \text{Motor Inertia} = .014 \text{ lb-in-s}^2 = (0.00158 \text{ kg} \cdot \text{m}^2)$



Servo Drive
SVA-2300 Retired

SureServo Motor



- SVM-220** \$1,000.00
SVM-220B (w/brake) \$1,367.00

Motor Power Cable (1)



- SVC-PHH-010 (10')** \$192.00
SVC-PHH-020 (20') \$253.00
SVC-PHH-030 (30') \$312.00
SVC-PHH-060 (60') Retired

Motor Encoder Cable (1)



- SVC-EHH-010 (10')** \$153.00
SVC-EHH-020 (20') \$171.00
SVC-EHH-030 (30') Retired
SVC-EHH-060 (60') \$250.00

ZIPLink I/O Interface



- ZL-RTB50** \$74.00
and one cable below:
ZL-SVC-CBL50 (0.5m) \$48.50
ZL-SVC-CBL50-1 (1m) \$51.00
ZL-SVC-CBL50-2 (2m) \$58.00

3 kW Medium Inertia System

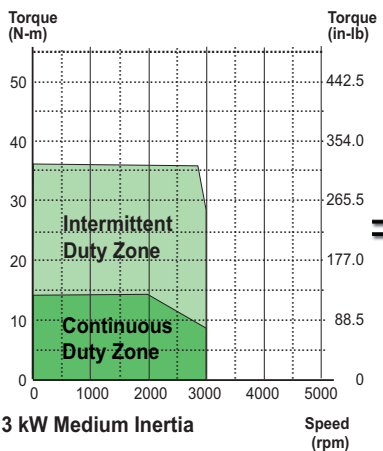

3 kW Medium Inertia

$J_m = \text{Motor Inertia} = 0.038 \text{ lb-in-s}^2 = (0.00433 \text{ kg} \cdot \text{m}^2)$



Servo Drive
SVA-2300 Retired

SureServo Motor



- SVM-230** Retired
SVM-230B (w/brake) Retired

Motor Power Cable (1)



- SVC-PHH-010 (10')** \$192.00
SVC-PHH-020 (20') \$253.00
SVC-PHH-030 (30') \$312.00
SVC-PHH-060 (60') Retired

Motor Encoder Cable (1)



- SVC-EHH-010 (10')** \$153.00
SVC-EHH-020 (20') \$171.00
SVC-EHH-030 (30') Retired
SVC-EHH-060 (60') \$250.00

ZIPLink I/O Interface



- ZL-RTB50** \$74.00
and one cable below:
ZL-SVC-CBL50 (0.5m) \$48.50
ZL-SVC-CBL50-1 (1m) \$51.00
ZL-SVC-CBL50-2 (2m) \$58.00



NOTE: All Motor Power Cables include brake power wires for the optional motor brake.

SureServo Communications Cables for Multi-drop Networks

Product	Price	Description
SVC-MDCOM-CBL	\$43.00	RS-422/485 serial communication cable for use with multidrop networks; 3ft length; IEEE 1394 plug to unterminated wires; compatible with all SureServo systems. Facilitates connection between the SureServo drive serial port and host controllers.
SVC-232RJ12-CBL-2 *	\$12.50	ZIPLink SureServo Drives cable with 6-pin RJ12 connector to a 6-pin IEEE 1394 connector, shielded, twisted pair, 2.0 meter (6.6 ft.) length. For RS-232 connection to all SureServo amplifiers.
SVC-485RJ12-CBL-2 *	\$15.00	ZIPLink SureServo amplifier communication cable, RJ12 male to 6-pin IEEE 1394 connector, shielded, twisted pair, 2.0 meter (6.6 ft.) length. Cable used in conjunction with ZL-CDM-RJ12xxx distribution module can access a compatible RS-485 device network.
SVC-485HD15-CBL-2 *	\$13.50	ZIPLink SureServo Drives cable with a HD 15-pin male to a 6-pin IEEE 1394 connector, shielded, twisted pair, 2.0 meter (6.6 ft.) length. For RS-485 connection to all SureServo amplifiers.



* Refer to the ZIPLinks Wiring Solutions section for complete information regarding the ZIPLink cables.



AC Servo System Software

SureServo Pro configuration software

SureServo Pro is an optional free downloadable configuration software package for the SureServo drives. With SureServo Pro installed, the personal computer may be directly connected to the servo drive's serial port via the PC's RS-232 serial port*. A six-foot configuration cable ([SVC-PCCFG-CBL](#), \$37.50) is available to make the connection between the drive serial port and PC DB-9 serial port simple.

**Note: Use our [USB-RS232](#) converter cable in conjunction with the [SVC-PCCFG-CBL](#) cable on PCs having only USB ports.*

Features

- Quick Start - The basic setup when you have limited time and just want to get up and running ASAP.
- Maintenance keypad allows the user to operate the servo system from the PC. This is a great aid during start-up to allow the servo to perform some basic motion and to check the I/O.
- Detailed - The complete setup for all the drive parameters
- Tune and check the servo response live using the scope feature.
- Upload and download the drive setup. Save the drive setup as a file for future use.
- Edit the drive setup
- View all drive faults
- Trend drive variables in real time

Parameter views

The SureServo Pro configuration tool logically organizes over 165 servo drive parameters into five tabbed groups. Each parameter has a factory default that usually allows the servo to run "out-of-the-box".

The parameters can be easily changed with available options or setting ranges displayed. Tuning modes and parameters can also be changed using SureServo Pro. After the parameters have been defined, the complete setup can be stored and archived. Drive configurations can be uploaded, edited, saved, and downloaded as often as necessary.

Parameter View Example Screen - Basic Parameters

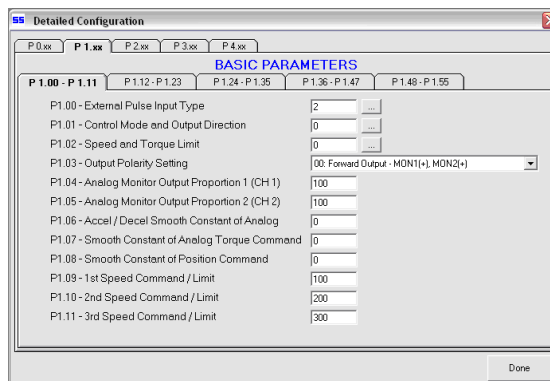

SureServo Software and Configuration Cables

Product	Price	Description
SV-PRO	Free	SureServo Pro configuration software for use with all SureServo servo systems. FREE download from www.sureservo.com or www.automationdirect.com websites.
SVC-PCCFG-CBL	\$37.50	Six-foot RS-232 communications cable; connects servo drive serial port to PC DB-9 serial port. For PCs having only USB ports, use our USB-RS232 converter cable in conjunction with the SVC-PCCFG-CBL cable.
SVC-485CFG-CBL-2	\$18.50	ZIPLink SureServo amplifier configuration cable, 6-pin IEEE 1394 connector to RJ45 connector, shielded, twisted pair, 2.0 meter (6.6 ft.) length. Use this cable in conjunction with our USB-485M serial adapter to connect any SureServo amplifier to a PC. Eliminates the need to reprogram networked servo drives from RS485 to RS232 when connecting to a PC.

* Refer to the ZIPLinks Wiring Solutions section for complete information regarding ZIPLink cable [SVC-485CFG-CBL-2](#).

AC Servo System Software

SureServo Pro configuration software - Parameter views (continued)

Maintenance screen

A maintenance keypad allows the user to operate the servo system from the PC. This is a great aid during start-up to allow the servo to perform some basic motion and to check the I/O.

Parameter View Example Screen - Monitor Parameters

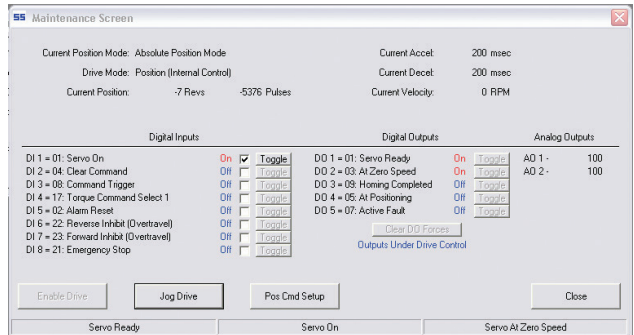
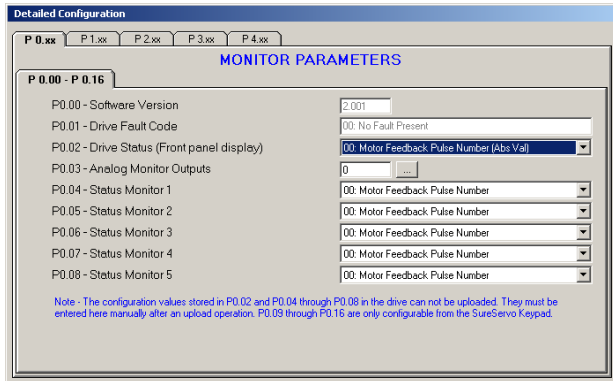

Parameter View Example Screen - Extended Parameters

Scope

SureServo Pro includes a powerful scope function that allows the user to have as many as three channels of data displayed simultaneously. Each channel has a drop-down table to select the data to be displayed. The scope also has a trigger mode and timebase selection. This function is a valuable tool for tuning SureServo drives.

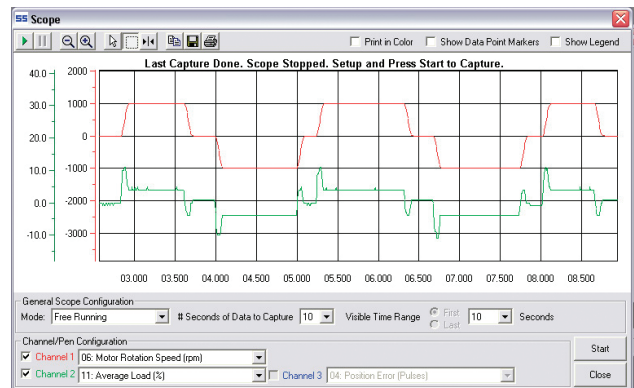
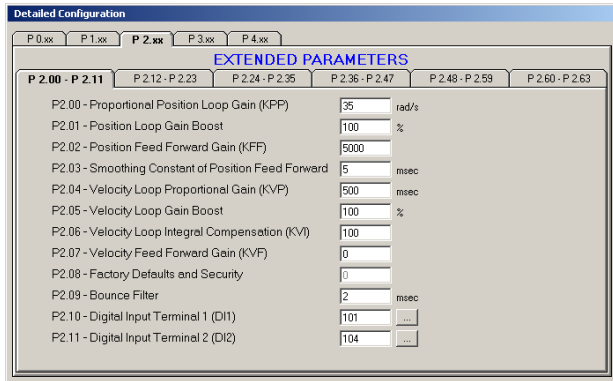

Parameter View Example Screen - Communication Parameters

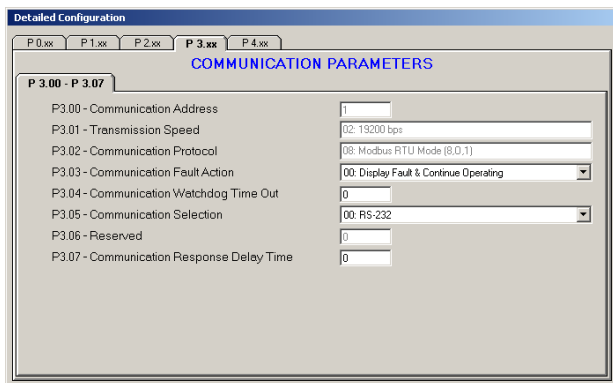



AC Servo Drive Specifications

Servo drive overview

Power On LED

Main power is ON

Control Power Terminal

Single-phase power 230 VAC, 50/60 Hz is connected to L1 and L2

Main Power Terminal

Three-phase power 230 VAC, 50/60 Hz is connected to R, S and T

(Single-phase power 230 VAC 50/60 Hz may be connected to R and S for the low inertia systems)

Motor Output Terminal

The servo motor power cable is connected to U, V and W. Use our factory made and tested cables available in 10, 20, 30 or 60 foot lengths for easy connection.

Regenerative Resistor Terminal

1. When the internal regenerative resistor is used, the P and D terminal are connected together while the P and C connection is left open.
2. When an external regenerative resistor is used, it is connected across the P and C terminals while the P and D connection is left open. Use our factory approved resistors for "sure" results.

LED Display

The LED display has 5 full digits and is used to indicate servo status and alarms

Keypad

Five Function keys:

- MODE: Press to select or change mode
 NEXT: Press to shift left
 UP: Press to increase values
 DOWN: Press to decrease values
 ENTER: Press to enter value

I/O Interface

50-pin connector for interfacing the host controller (such as DirectLOGIC PLC) and other types of I/O signals.

Use our ZIPLink kit which provides DIN-rail mounted screw terminals for easy connection.

- Command inputs:
 - Pulse and Direction Encoder
 - Follower Analog Velocity/Torque
- (8) Digital Inputs
- (5) Digital Outputs
- (2) Analog Monitors
- Encoder Output (scalable)
A+, A-, B+, B-, Z+, Z-

Encoder Interface

20-pin connector for interfacing the servo motor encoder. Use our factory-made and tested cable available in 10, 20, 30 or 60 foot lengths for easy connection.

Serial Communication Interface

6-pin RS-485/422/232 interface to personal computer with SureServo Pro set-up software or host controller with Modbus RTU/ASCII protocol. Use our factory-made cables for easy connection to the PC or the host controller.

Ground Terminals



SureServo systems run "out-of-the-box"... but may be reconfigured for many applications!

The SureServo drives are fully digital and include over 165 programmable parameters. For convenience, the parameters are grouped into five categories:

1. Monitor parameters
2. Basic parameters
3. Extended parameters
4. Communication parameters
5. Diagnostic parameters.

All parameters have commonly used default values which allow you to operate the SureServo system "out-of-the-box". However, the programmability and large variety of parameters make the SureServo systems suitable for a very broad range of applications, including almost all types of general purpose industrial machinery such as assembly, test, packaging, machine tool, and robotics.



AC Servo Drive Specifications

Servo drive specifications

General Drive Specifications	
Permissible Frequency	50/60 Hz \pm 5%
Encoder Resolution / Feedback Resolution	2500 lines / 10000 ppr
Control of Main Circuit	SVPWM (Space Vector Pulse Width Modulation) Control
Tuning Modes	Easy / Auto / Manual
Dynamic Brake	Built-in control
Analog Monitor Outputs (2)	Monitor signal can be set by parameters (Output voltage range: \pm 8V; Resolution: 12.8 mV/count)
8 Programmable Digital Inputs (45 selectable functions)	Servo enable, Alarm reset, Gain switching, Pulse counter clear, Fault stop, CW/CCW over-travel Internal parameter selection, Torque limit activation, Velocity limit activation, Control mode selection
Scalable Encoder Output	Encoder signal output A, /A, B, /B, Z /Z, Line Driver
5 Programmable Outputs (9 selectable indicators)	Servo ready, Servo On, Low velocity, Velocity reached, In Position, Torque limiting, Servo fault, Electromagnetic brake control, Home search completed
Communication Interface	RS-232 / RS-485 / RS-422 / Modbus ASCII & RTU up to 115k Baud
Protective Functions	Overcurrent, Overvoltage, Undervoltage, Overload, Excessive velocity/position error, Encoder error, Regeneration error, Communication error
Installation Site	Indoor location (free from direct sunlight), no corrosive liquid and gas (far away from oil mist, flammable gas, dust)
Altitude	1000m [3281 ft] above sea level – maximum
Operating Temperature	0 to 55 °C [32 to 131 °F] (If operating temperature is above 55°C, forced cooling is required). For long-term reliability, the ambient temperature of SureServo systems should be under 45°C (113°F).
Storage Temperature	-20° to 65°C (-4° to 149°F)
Humidity	0 to 90% (non-condensing)
Vibration	9.81 m/s ² (1G) less than 20Hz, 5.88 m/s ² (0.6G) 20 to 50 Hz
Protection	IP 20
Agency Approvals	CE; UL Certified (U.S. and Canada)



AC Servo Drive Specifications

Servo drive specifications (continued)

Model and Mode Specific Drive Specifications									
AC Servo Model		SVA-2040			SVA-2100			SVA-2300	
Price		Retired			Retired			Retired	
Voltage Phase		Single-phase or Three-phase						Three-phase	
Voltage and Frequency Range		3-phase: 170~255 VAC @ 50/60 Hz ±5%; 1-phase: 200~255 VAC @ 50/60 Hz ±5%						170~255 VAC @ 50/60 Hz ±5%	
Main Circuit Input Current	Single Phase	3.4A @ 400W			8.0A @ 1kW			-	
	Three Phase	2.6A @ 400W			6.2A @ 1kW			13.6A @ 3kW	
Main Circuit Inrush Current		44A			77A			87A	
Main Circuit Power Cycling		Maximum 1 power cycle per minute							
Control Circuit Current and Voltage		43 mA @ 200~255 VAC, 1 phase							
Control Circuit Inrush Current		32A maximum							
Cooling System		Natural Air Circulation				Internal Cooling Fan			
Drive Heat Loss *	Motor driven *	SVL-201(B)	SVL-202(B)	SVL-204(B)	SVL-207(B)	SVL-210(B)	SVM-210(B)	SVM-220(B)	SVM-230(B)
	Heat Loss	12W	15W	20W	35W	45W	50W	75W	80W
Weight		1.5 kg [3.3 lb]			2kg [4lb]			3kg [7lb]	
Position Control Mode	Max. Input Pulse Frequency		Max. 500 kpps (Line driver); Max. 200 kpps (Open collector)						
	Pulse Type		Pulse + Direction, A phase + B phase Quadrature, CCW pulse + CW pulse						
	Command Source		External pulse train / Onboard indexer						
	Smoothing Strategy		Low-pass and P-curve filter						
	Electronic Gear		Electronic gear N/M multiple; N: 1~32767, M: 1~32767(1/50<N/M<200)						
	Torque Limit Operation		Set by parameters or by analog input						
	Feed Forward Compensation		Set by parameters						
Velocity Control Mode	Analog Input Command	Voltage Range		Bipolar ±10 VDC					
		Input Resistance		10 k					
		Time Constant		2.2 μs					
		Resolution		(Varies with input voltage) 13 bits @ 0V~1V; 13~10 bits @ 1V~2V; 10 bits @ 2V~10V					
	Speed Control Range		1:5000						
	Command Source		External analog signal / Onboard indexer						
	Smoothing Strategy		Low-pass and S-curve filter						
	Torque Limit Operation		Set by parameters or via analog input						
	Frequency Response Characteristic		Maximum 450 Hz						
	Speed Accuracy (at rated rotation speed)		0.01% or less at 0 to 100% load fluctuation 0.01% or less at ±10% power fluctuation 0.01% or less at 0 to 50°C ambient temperature fluctuation						
Torque Control Mode	Analog Input Command	Voltage Range		Bipolar ±10 VDC					
		Input Resistance		10 kΩ					
		Time Constant		2.2 μs					
		Resolution		10 bits					
	Permissible Time for Overload		8 sec. under 200% rated output						
	Command Source		External analog signal / Onboard indexer						
	Speed Limit Operation		Set by parameters or via analog input						

* Drive heat loss varies depending upon which motor is connected to the drive.



AC Servo Motor Specifications

Servo motor overview

Motor Power and Brake Connector

1-foot cable with 6-position connector (Not liquid tight)

750W and below

Encoder Connector

1-foot cable with 9-position connector (Not liquid tight)



Without Shaft Seal

(not liquid tight)

IP65 Housing

Low Inertia Motors

- 100W 40 mm flange
- 200W 60 mm flange
- 400W 60 mm flange
- 750W 80 mm flange

Keyless Shafts

- 100W 8 mm diameter
- 200W 14 mm diameter
- 400W 14 mm diameter
- 750W 19 mm diameter

All SureServo motors have keyless shafts for use with servo-grade clamp or compression couplings.

Motor Power and Brake Connector

(Liquid tight when using AutomationDirect cables)

Encoder Connector

(Liquid tight when using AutomationDirect cables)

1 kW and above

IP65 Housing

Low and Medium Inertia Motors

- Low Inertia Model
- 1 kW 100 mm flange
- Medium Inertia Models
- 1 kW 130 mm flange
 - 2 kW 180 mm flange
 - 3 kW 180 mm flange

Keyless Shafts

- Low Inertia Model
- 1 kW 22 mm diameter
- Medium Inertia Models
- 1 kW 22 mm diameter
 - 2 kW 35 mm diameter
 - 3 kW 35 mm diameter

With Shaft Seal

(liquid tight)





AC Servo Motor Specifications

Motor Specifications												
Inertia Range		Low					Medium					
Model Name: Sxx-xxx		SVL-201	SVL-202	SVL-204	SVL-207	SVL-210	SVM-210	SVM-220	SVM-230			
Price		Retired	Retired	Retired	Retired	Retired	Retired	\$1,000.00	Retired			
Model with brake: Sxx-xxxB		SVL-201B	SVL-202B	SVL-204B	SVL-207B	SVL-210B	SVM-210B	SVM-220B	SVM-230B			
Price		Retired	Retired	Retired	Retired	Retired	Retired	\$1,367.00	Retired			
Rated output power	W	100	200	400	750	1000	1000	2000	3000			
Rated torque	N·m	0.32	0.64	1.27	2.39	3.3	4.8	9.4	14.3			
	lb·in	2.8	5.7	11.2	21.2	29.2	42.5	83.2	126.6			
Maximum torque	N·m	0.95	1.91	3.82	7.16	9.9	15.7	23.5	35.8			
	lb·in	8.4	16.9	33.8	63.4	87.6	138.9	208.0	316.8			
Rated speed	rpm	3000					2000					
Max. speed	rpm	5000			4500		3000					
Rated current	A	1.1	1.7	3.3	5.0	6.8	5.6	13.1	17.4			
Max. current	A	3.0	4.9	9.3	14.1	18.7	17.6	31.4	42.3			
Drive input current	1 phase A	1.0	1.7	3.4	5.9	8.0	8.0	-	-			
	3 phase A	0.8	1.3	2.6	4.7	6.2	6.2	9.1	13.6			
Max. radial shaft load	N	78.4	196		343	490		784				
	lb	18	44		77	110		176				
Max. thrust shaft load	N	39.2	68.6		98			392				
	lb	9	15		22			88				
Brake	Voltage	VDC										
	Current	ADC		0.21		0.38		0.4		0.75		
	Holding Torque	N·m	0.32		1.27		2.55		9.3		7.5	
		lb·in	2.83		11.24		22.57		82.3		66.38	
Rotor inertia w/o brake	kg·m ²	0.03E-4	0.18E-4	0.34E-4	1.08E-4	2.6E-4	5.98E-4	15.8E-4	43.3E-4			
	lb·in·s ²	0.27E-4	1.59E-4	3.0E-4	9.56E-4	23.0E-4	52.9E-4	139.8E-4	383.2E-4			
Rotor inertia with brake	kg·m ²	0.06E-4	0.28E-4	0.44E-4	1.32E-4	3.1E-4	8.8E-4	27.8E-4	56.3E-4			
	lb·in·s ²	0.53E-4	2.48E-4	3.9E-4	11.7E-4	27.4E-4	77.9E-4	246.0E-4	498.3E-4			
Mechanical time constant	ms	0.6	0.9	0.7	0.6	1.7	1.4	1.6	0.9			
Static friction torque	N·m	0.02	0.04		0.08	0.49	0.29	0.98				
Torque constant-KT	N·m/A	0.32	0.39	0.4	0.5	0.56	0.91	0.77	0.86			
Voltage constant-KE	V/rpm	33.7E-3	41.0E-3	41.6E-3	52.2E-3	58.4E-3	95.71E-3	81.1E-3	90.5E-3			
Armature resistance	Ω	20.3	7.5	3.1	1.3	2.052	1.98	0.6	0.162			
Armature inductance	mH	32	24	11	6.3	8.4	13.2	6.1	2.3			
Electrical time constant	ms	1.6	3.2	3.2	4.8	4.1	6.7	10.1	14.2			
Motor Type	Brushless, AC, permanent magnet [Neodymium (Nd), Iron (Fe), Boron (B)]											
Insulation class	Class F											
Insulation resistance	>100 MΩ, 500 VDC											
Insulation strength	1500 VAC, 50 Hz, 60 seconds											
Ambient temperature range	0 to 40°C (32°F to 104°F)											
Operating temperature (measured case temperature)	70°C (158°F)											
Maximum operating temperature (measured case temperature)	70°C + 40°C = 110°C (230°F)											
Storage temperature	-20 to 65°C (-4 to 149°F)											
Operating humidity	20 to 90% RH (non-condensing)											
Storage humidity	20 to 90% RH (non-condensing)											
Vibration / Shock	2.5G / 5.0G											
Environmental rating	IP65 motor body; IP40 shaft; IP20 connector					IP65 (requires SureServo cables)						
Weight without brake	kg	0.5	0.9	1.3	2.5	4.7	4.8	12.0	17.0			
	lb	1.1	1.98	2.87	5.5	10.36	10.58	26.46	37.48			
Weight with brake	kg	0.7	1.4	1.8	3.4	6.3	7.5	19.0	24.0			
	lb	1.54	3.09	3.97	7.5	13.89	16.53	41.89	52.9			
Agency Approvals	CE; UL recognized (U.S. and Canada)											

NOTE: U.S. customary units are for reference only.

Standard wiring examples



This wiring diagram shows basic wiring only, and additional wiring configurations are possible for some I/O. Refer to the "Installation and Wiring" chapter of the User Manual for more detailed wiring information.

Position (Pr & Pt) Control Modes

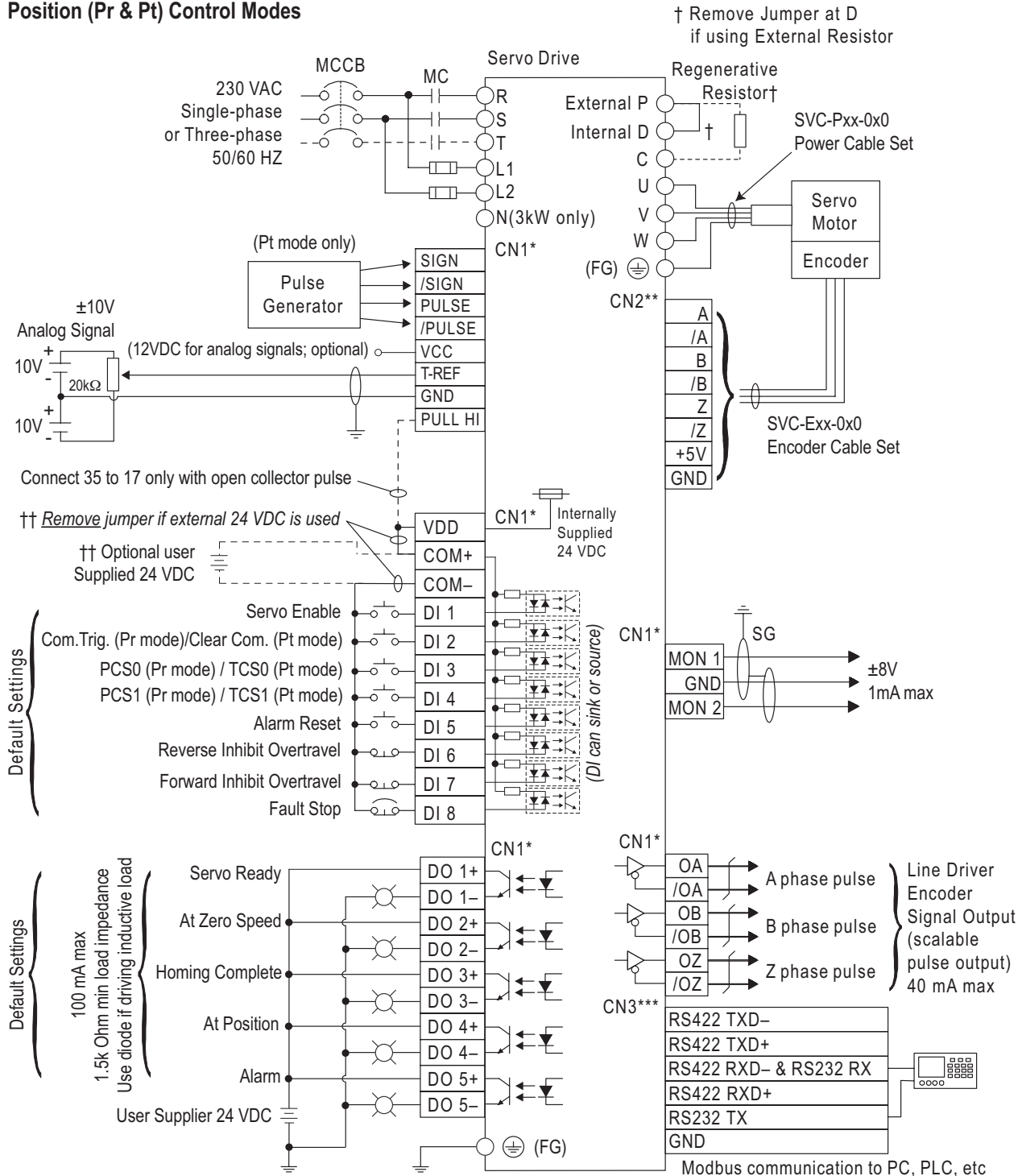

* Use connection kit part #s ZL-RTB50 & ZL-SVC-CBL-50(-x) for CN1 terminal connections.
 ** Use cable part # SVC-Exx-0x0 for CN2 terminal connections.
 *** Use cable part # SVC-MDCOM-CBL for CN3 terminal Modbus network connections.



AC Servo System Wiring

Standard wiring examples (continued)



This wiring diagram shows basic wiring only, and additional wiring configurations are possible for some I/O. Refer to the "Installation and Wiring" chapter of the User Manual for more detailed wiring information.

Velocity and Torque Control Modes

† Remove Jumper at D if using External Resistor

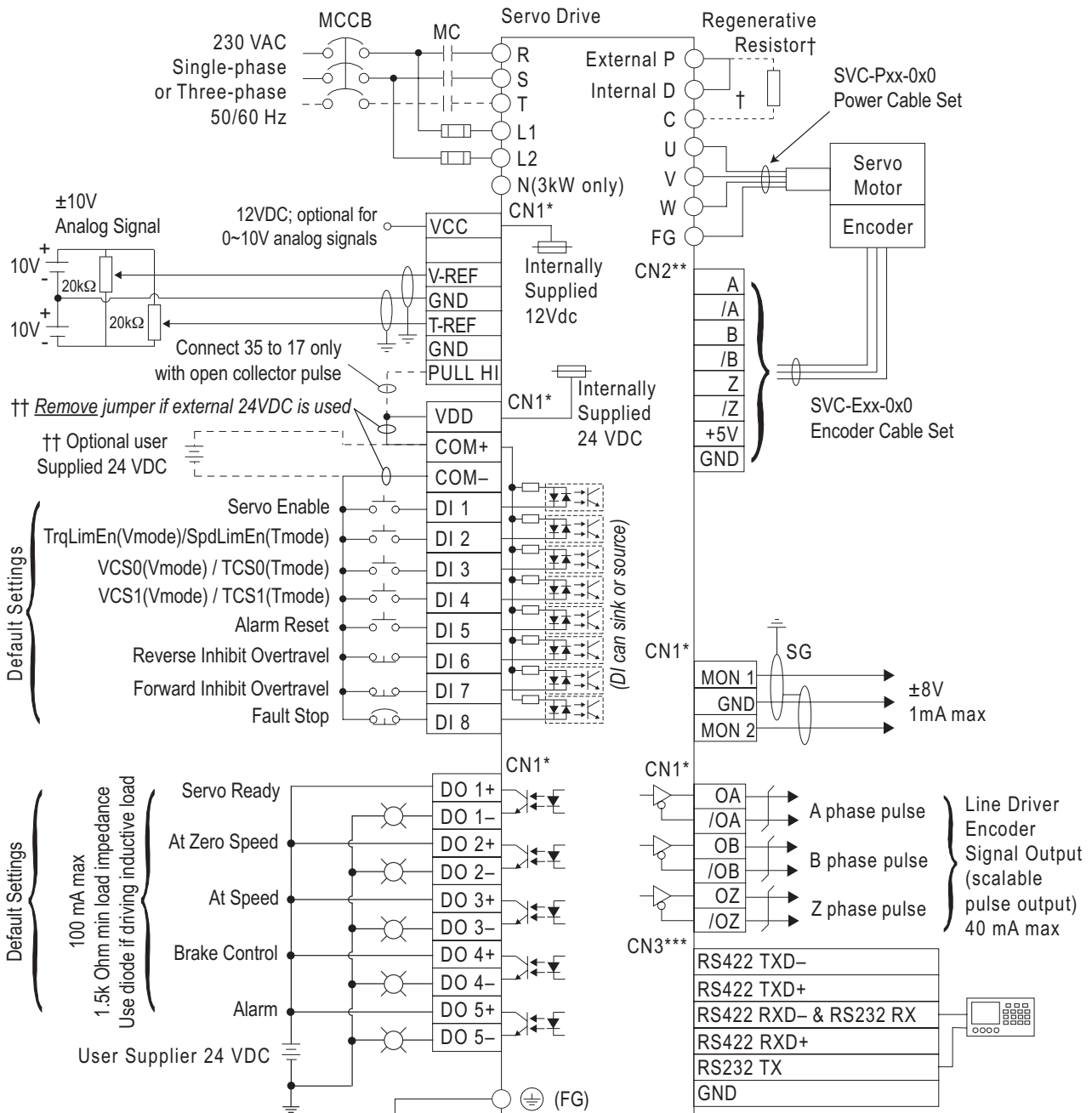

* Use connection kit part #s ZL-RTB50 & ZL-SVC-CBL-50(-x) for CN1 terminal connections.

** Use cable part # SVC-Exx-0x0 for CN2 terminal connections.

*** Use cable part # SVC-MDCOM-CBL for CN3 terminal Modbus network connections.



AC Servo System Dimensions

Servo drive dimensions

SVA-2040



Recommended user supplied mounting screw is M6.
Tighten to 14 kgf-cm (1.37 N-m).

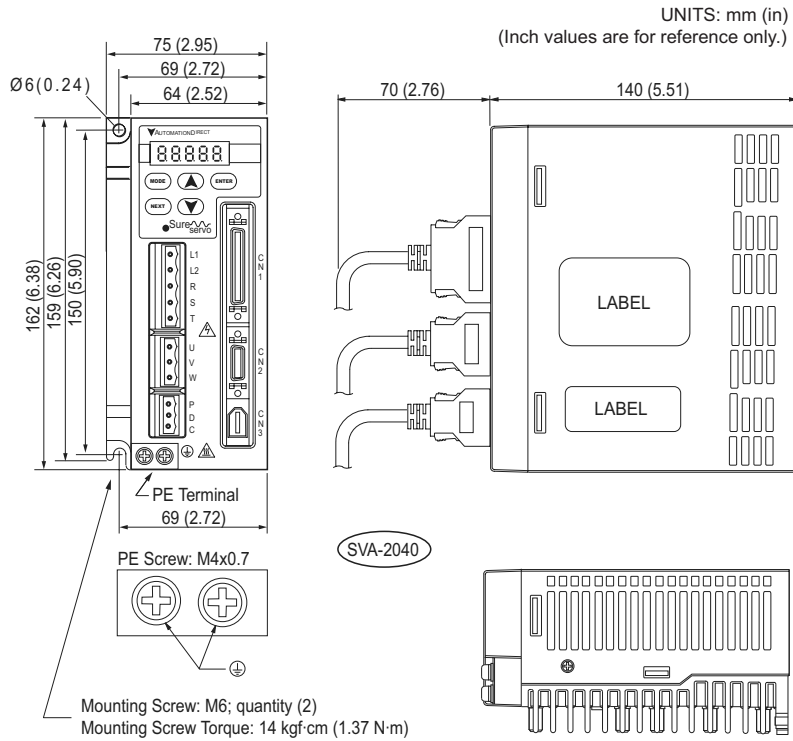

SVA-2100



Recommended user supplied mounting screw is M6.
Tighten to 14 kgf-cm (1.37 N-m).

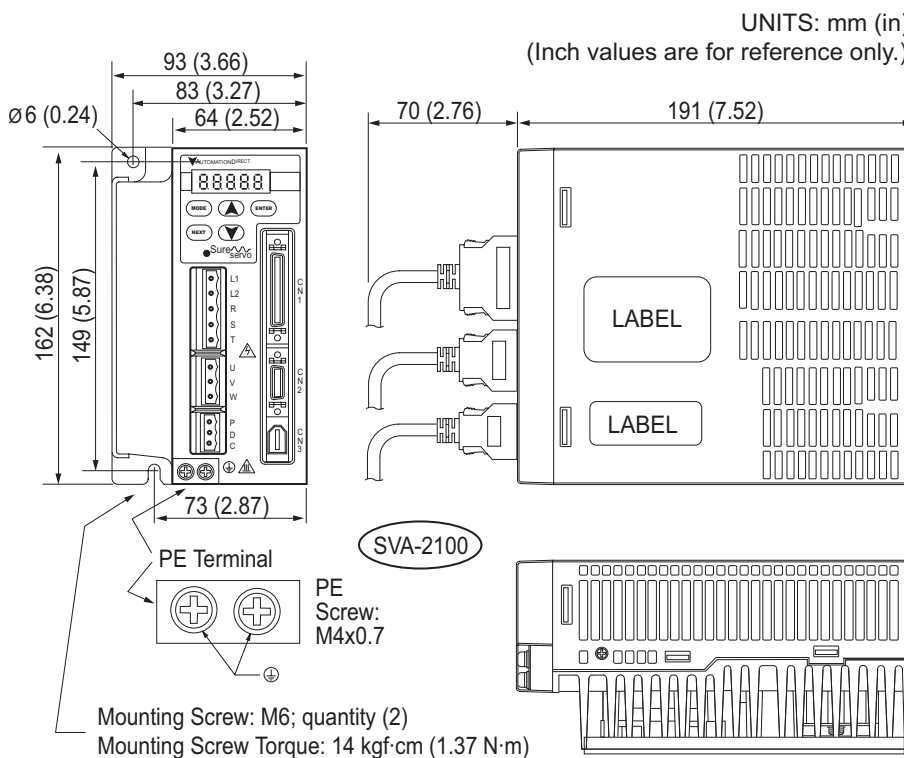



AC Servo System Dimensions

Servo drive dimensions (continued)

SVA-2300



Recommended user supplied mounting screw is M6.
Tighten to 14 kgf-cm (1.37 N-m).

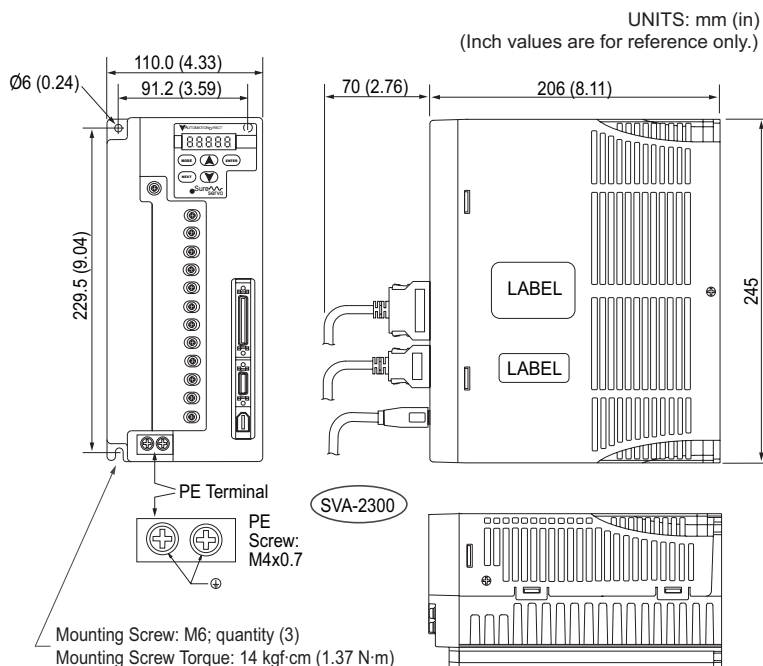

Servo motor dimensions

Low inertia models **SVL-201(B)**, **SVL-202(B)**, **SVL-SVL-204(B)**, **SVL-207(B)**

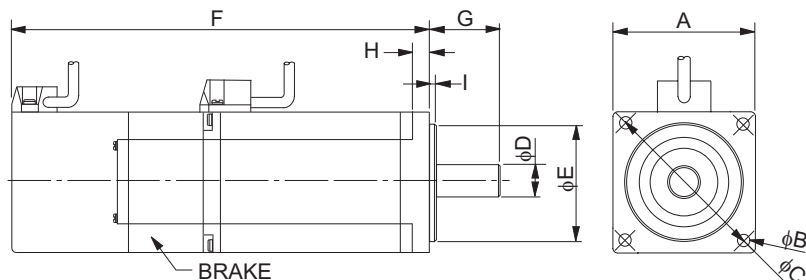

SureServo® Motor Dimensions – 100W-750W Low Inertia				
Dimension	SVL-201(B)	SVL-202(B)	SVL-204(B)	SVL-207(B)
A	40 [1.575]	60 [2.362]	80 [3.15]	
B	4.5 [0.1772]	5.5 [0.2165]	6.6 [0.2598]	
C	46 [1.811]	70 [2.756]	90 [3.543]	
D	8 +0.0/-0.009 (8h6)	14 +0.0/-0.011 (14h6)	19 +0.0/-0.013 (19h6)	
E	30 +0.0/-0.021 (30h7)	50 +0.0/-0.025 (50h7)	70 +0.0/-0.030 (70h7)	
F (w/o brake)	100.1 [3.941]	102.4 [4.032]	124.4 [4.898]	135 [5.315]
F (with brake)	135.7 [5.343]	137 [5.394]	159 [6.26]	171.6 [6.756]
G	25 [0.98]	30 [1.18]	35 [1.38]	
H	5 [0.197]	6 [0.236]	8 [0.315]	
I	2.5 [0.098]	3 [0.118]		
Cable length	300mm (12 inches)			

UNITS: mm [in]. (Inches are for reference only; not included on diameter dimensions for accuracy.)

AC Servo System Dimensions

Servo motor dimensions (continued)

Low inertia models SVL-210(B)

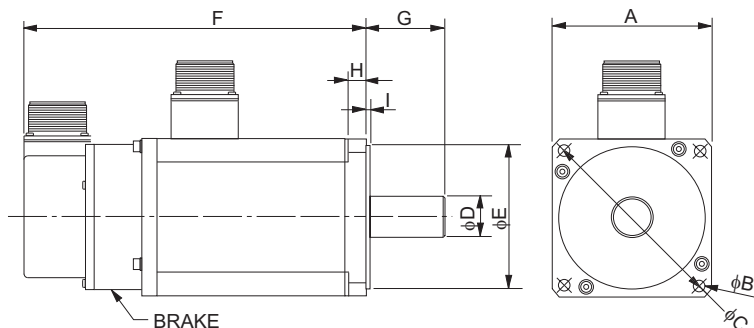

SureServo® Motor Dimensions -1000W Low Inertia	
Dimension	SVL-210(B)
A	100 [3.937]
B	9 [0.3543]
C	115 +0.2/-0.2 [4.528]
D	22 +0.0/-0.013 (22h6)
E	95 +0.0/-0.035 (95h7)
F (w/o brake)	158 [6.22]
F (with brake)	190 [7.48]
G	45 [1.77]
H	17 [0.669]
I	7 [0.28]

UNITS: mm [in] (Inches are for reference only; not included on diameter dimensions for accuracy.)

Medium inertia models SVM-210(B), SVM-220(B), SVM-230(B)

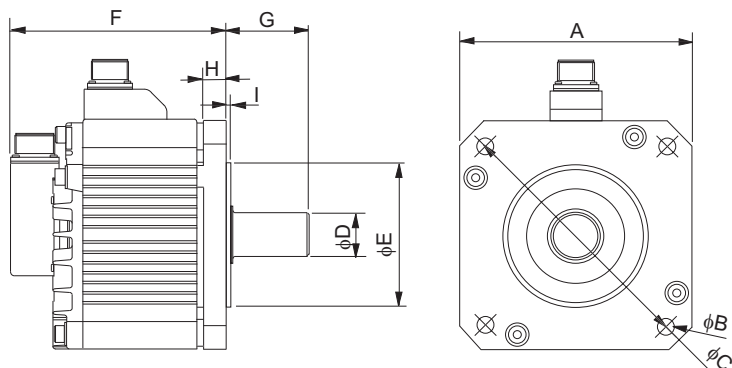

SureServo® Motor Dimensions -1000W-3000W Medium Inertia			
Dimension	SVM-210(B)	SVM-220(B)	SVM-230(B)
A	130 [5.118]	180 [7.087]	
B	9 [0.3543]	13.5 [0.5315]	
C	145 +0.2/-0.2 [5.709]	200 +0.2/-0.2 [7.874]	
D	22 +0.0/-0.013 (22h6)	35 +0.0/-0.016 (35h6)	
E	110 +0.0/-0.035 (110h7)	114.3 +0/-0.035 (114.3h7)	
F (w/o brake)	143 [5.63]	164 [6.457]	212 [8.35]
F (with brake)	181 [7.126]	213 [8.386]	258 [10.16]
G	55 [2.17]	75 [2.95]	
H	15 [0.591]	20 [0.787]	
I	4 [0.157]		

UNITS: mm [in] (Inches are for reference only; not included on diameter dimensions for accuracy.)



AC Servo System Accessories

Accessories

External Regeneration Resistors

Use external resistors to provide additional regenerative capacity and to dissipate heat away from the servo drive.

Part Number	Resistance	SureServo Drives	Price
GS-25P0-BR	40Ω	SVA-2040	Retired
GS-2010-BR-ENC	20Ω	SVA-2100, SVA-2300	\$358.00



Resistor GS-25P0-BR

AC Line Filters

Input EMI filters reduce electromagnetic interference or noise on the input side of the servo drive. They are required for CE compliance and recommended for installations prone to or sensitive to electromagnetic interference.

SureServo® Drives	AC Input Power	EMI Filter Rating	EMI Filter Part Number	Price
SVA-2040	Single-Phase	250V, 1-phase, 20A	20DRT1W3S	\$73.00
	Three-Phase	250V, 3-phase, 10A	10TDT1W4C	\$85.00
SVA-2100	Single-Phase	250V, 1-phase, 20A	20DRT1W3S	\$73.00
	Three-Phase	250V, 3-phase, 10A	10TDT1W4C	\$85.00
SVA-2300	Three-Phase	250V, 3-phase, 26A	26TDT1W4C	Retired



AC Line Filter 10TDT1W4C



Note: These EMI Filters are electrically compatible with the SureServo drives. However, they are intended to be mounted next to the servo drive. Do not mount the filter under the drive. The drive mounting holes on these units are intended to be used only with AutomationDirect's line of VFDs.

Edison Fuses & Fuji Contactors

SureServo® Drives	Input Type	Input Voltage	Edison Fuse - Class CC	Price*	Contactor**	Price
SVA-2040	Main Input Power	230V 3-Phase	HCTR4	\$158.00	SC-E02-xxx	varies
SVA-2100			HCTR7-5	\$176.00	SC-E03-xxx	varies
SVA-2300			HCTR15	\$149.00	SC-E04-xxx	varies
SVA-2040	Control Input Power	230V 1-phase	HCTR4	\$158.00	SC-E02-xxx	varies
SVA-2100			HCTR10	\$158.00	SC-E03-xxx	varies
SVA-2040 SVA-2100 SVA-2300		230V 1-phase	HCTR2-5	\$162.00		

* Fuses are sold in packages of 10.

** Note: For contactors, xxx = coil voltage (for example, SC-E02P-220VAC).



Fuji Contactor SC-E02-xxx



Edison Fuse HCTRx

SureServo Connector Kit (replacement)

This kit contains replacement input, output, and brake connectors for SureServo drives.

Part Number	Description	SureServo Drives	Price
SVA-CON-1	SureServo connector kit, replacement, includes (1) input power connector, (1) output power connector and (1) brake resistor connector.	SVA-2040 SVA-2100	\$22.00



SVA-CON-1