



DIN Rail Mounted Universal Temperature Transmitters - Programmable

Features - Programmable Models



XTD2-0-UNV-S



XTD2-0-UNV-P

- Sensor Types:
 - Thermocouple Types J, K, T, E, N, R, S, U, B, C, D, L, A
 - RTD Types Pt100, Pt200, Pt500, Pt1000, Pt50, Ni100, Ni120, Cu50, Cu100 (2, 3 or 4-wire)
 - Linear Resistance 10 to 400 Ohms, 10 to 2000 Ohms (2, 3 or 4-wire)
 - Millivolts -20 to 100 mV
- Measuring range configurable within the full range of the sensor type selected
- Selectable units of °F, °C, K, Ohm and mV
- Choose from internal, external, or user defined fixed value reference junction compensation for thermocouple inputs
- Wire resistance compensation for 2-wire RTDs
- Transmitter is powered by 11-36 VDC and is reverse-polarity protected
- Output is linearized 2-wire current loop and can be configured for 4-20mA or 20-4mA
- Selectable up scale or down scale signal for sensor lead break or short circuit detection (NAMUR NE 43 fault response)
- Adjustable digital filter time constant to compensate for undesirable input fluctuations
- Mounts on 35mm DIN rail in a control panel
- 2kVAC isolation between input and output
- Quick and easy configuration with Free ProSense Field Device Configurator software and XT-USB cable (purchased separately) – NO decade box, meters, or signal generators needed!



DIN Rail Mounted Universal Temperature Transmitters - Programmable					
Part No.	Description	Pcs/Pkg	Wt (lb)	Drawing Link	Price
<u>XTD2-0-UNV-S</u>	ProSense programmable temperature transmitter, isolated, RTD, thermocouple, millivolt or potentiometer input, deg F or deg C, current output, 11-36 VDC operating voltage, 35mm DIN rail mount, removable screw terminal plugs.	1	0.20	PDF	\$136.00
<u>XTD2-0-UNV-P</u>	ProSense programmable temperature transmitter, isolated, RTD, thermocouple, millivolt or potentiometer input, deg F or deg C, current output, 11-36 VDC operating voltage, 35mm DIN rail mount, removable push-in terminals.	1	0.40	PDF	\$136.00



Scan the QR Code above or click to view the XTD2 Series product insert.



DIN Rail Mounted Universal Temperature Transmitters - Programmable

DIN Rail Mounted Universal Temperature Transmitters - Programmable General Specifications			
	<i>Input Type</i>	<i>Programmable Measuring Range Limits</i>	<i>Min. Span</i>
<i>Inputs</i>	Pt100 RTD Pt200 RTD Pt500 RTD Pt1000 RTD (to IEC 751) a=0.003851)	-328 to 1562°F (-200 to 850°C) -328 to 1562°F (-200 to 850°C) -328 to 932°F (-200 to 500°C) -328 to 482°F (-200 to 250°C)	18°F (10°C)
	Pt100 RTD (to JIS C1604) (a=0.0039)	-328 to 950°F (-200 to 510°C)	18°F (10°C)
	Ni100 RTD Ni120 RTD (to DIN 43760) (a=0.006180)	-76 to 482°F (-60 to 250°C)	18°F (10°C)
	Ni100 RTD Ni120 RTD (to OIML, GOST) (a=0.006170)	-76 to 356°F (-60 to 180°C)	18°F (10°C)
	Pt50 RTD Pt100 RTD (to GOST) (a=0.00390)	-301 to 2012°F (-185 to 1100°C) -328 to 1562°F (-200 to 850°C)	18°F (10°C)
	Pt100 (Callendar van Dusen) Nickel polynomial Copper polynomial	The measuring range limits are specified by entering the limit values that depend on the coefficients A to C and R0.	18°F (10°C)
	Cu50 RTD Cu100 RTD (to OIML, GOST) (a=0.004280)	-292 to 392°F (-180 to 200°C)	18°F (10°C)
	Cu50 RTD (to OIML, GOST) (a=0.004260)	-58 to 392°F (-50 to 200°C)	18°F (10°C)



DIN Rail Mounted Universal Temperature Transmitters - Programmable

DIN Rail Mounted Universal Temperature Transmitters - Programmable General Specifications		
<i>Input Type</i>	<i>Programmable Measuring Range Limits</i>	<i>Min. Span</i>
RTDs: • Connection type: 2-, 3-, or 4-wire connection • Software compensation of cable resistance possible in the 2 wire system (0-30Ω) • Sensor cable resistance max. 50Ω per cable in the 3 and 4 wire system • Sensor current: ≤ 0.3mA		
Resistance Ω	10 to 400 Ω 10 to 2000 Ω	10 Ω
Thermocouples: Type A Type B Type E Type J Type K Type N Type R Type S Type T (to 60584, Part 1)	32 to 4532°F (0 to +2500°C) 104 to 3308°F (40 to +1820°C) -482 to 1832°F (-250 to +1000°C) -346 to 2192°F (-210 to +1200°C) -454 to 2501°F (-270 to +1372°C) -454 to 2372°F (-270 to +1300°C) -58 to 3214°F (-50 to +1768°C) -58 to 3214°F (-50 to +1768°C) -328 to 752°F (-200 to +400°C)	90°F (50°C)
Thermocouples: Type C Type D (to ASTM E988)	32 to 4199°F (0 to +2315°C) 32 to 4199°F (0 to +2315°C)	90°F (50°C)
Thermocouples: Type L Type U (to DIN 43710)	-328 to 1652°F (-200 to +900°C) -328 to 1112°F (-200 to +600°C)	90°F (50°C)
Thermocouple: Type L (to GOST)	-328 to 1472°F (-200 to +800°C)	90°F (50°C)
Thermocouples: • Internal cold junction (Pt100) or external programmable fixed value, -40 to 185°F (-40 to 85°C) • Accuracy of cold junction: ± 1.8°F (1°C) • Sensor current: 30nA • Maximum sensor wire resistance 10kΩ (If the sensor wire resistance is greater than 10 kΩ, an error message is output in accordance with NAMUR NE89.)		
Millivolt (mV)	-20 to 100 mV	5 mV



DIN Rail Mounted Universal Temperature Transmitters - Programmable

DIN Rail Mounted Universal Temperature Transmitters - Programmable General Specifications Cont.		
Output	Output Signal	4-20 mA, 20-4 mA programmable
	Signal Transmission	Output linear to temperature
	Fault Signal	Under ranging / Standard / 3.8 mA Over ranging / Standard / 20.5 mA Sensor failure; sensor short-circuit / To NAMUR NE43 / ≤ 3.6 mA (low) or ≥ 21 to 23 mA (high)
	Max. Load Impedance	$(V_{\text{powersupply}} - 11 \text{ V}) / 0.023 \text{ A}$ e.g. $(24\text{V}-11\text{V}) / 0.023\text{A}=565.22\Omega$
	Galvanic Isolation	2 kV AC (input/output)
	Input Current Requirement	≤ 3.5 mA
	Current Limit	≤ 23 mA
	Switch on Delay	≤ 7 seconds (during power up output current = 3.8 mA)
	Response Time	1 second
	Digital Filter	0 to 120 seconds (programmable)
	Power Supply	11 to 36 VDC, polarity protected
Accuracy	Reference Conditions	Calibration temperature 77°F ± 5.4 °F (25°C)
	Maximum Measuring Error	See Table 1
	Influence of Power Supply	$\leq \pm 0.01\%/V$ deviation from 24 V
	Load Influence	$\leq \pm 0.02\%/100 \Omega$
	Long Term Stability	$\leq 0.1 \text{ K / Year}$ or $m 0.05\% / \text{Year}$
Installation	Orientation	Mount vertically to ensure maximum accuracy
Environmental	Ambient	-40 to 185°F (-40 to 85°C)
	Storage	-58 to 212°F (-50 to 100°C)
	Climate Class	As per IEC 60 654-1, class B2
	Ingress Protection	IP20
	Shock and Vibration	0.7g / 2 to 100 Hz (general vibration stress) as per DNVGL-CG-0339 : 2015 and DIN EN 60068-2-27. Shock resistance as per KTA 3505 (section 5.8.4 Shock test)
	EMC Immunity	See Table 2
	Moisture Condensation	Not Permitted
Construction	Materials	Housing: Polycarbonate (PC); Potting: Silgel612EH
	Terminals	Pluggable screw terminal, max. 2.5 mm ² (14 AWG) solid, or strand with wire end sleeve, recommended torque 0.5-0.7Nm (4.5-6.2lb.in)
Human Interface	Display	Illuminated green power LED, Red status LED
Approvals		CE, CSA, RoHS

Table 1 - Maximum Measuring Error

	Type	Measurement Accuracy*
Resistance Thermometer (RTD)	Pt100	0.18°F (0.10°C)
	Pt1000	0.14°F (0.08°C)
Thermocouple TC	K	1.15°F (0.64°C)
	J	0.98°F (0.54°C)
	T	0.95°F (0.53°C)
	Measurement Range	Measurement Accuracy*
Resistance Transmitter (Ω)	10 to 400 Ω	120.7 m Ω
	10 to 2000 Ω	623.4 m Ω
Voltage Transmitters (mV)	-20 to 100 mV	37.36 μV

* Maximum measured error for the specified measuring range.

Note: For less common types see manual.

Table 2 - IEC Immunity

	IEC 61000-4-2	6 kV cont., 8 kV air	N/A
Discharge of Static Electricity	IEC 61000-4-2	6 kV cont., 8 kV air	N/A
Electromagnetic Fields	IEC 61000-4-3	0.08 to 2.7 GHz	10 V/m
Burst (Signal)	IEC 61000-4-4	1 kV (B)**	N/A
Transient Voltage	IEC 61000-4-5	1 kV unsym.	N/A
HF Coupling	IEC 61000-4-6	0.15 to 80 MHz	10V

** self recovery

pro^{ense} Temperature Transmitters - DIN Rail Mounted

Wiring

Sensor input

RTD, Ω: 4-, 3- and 2-wire

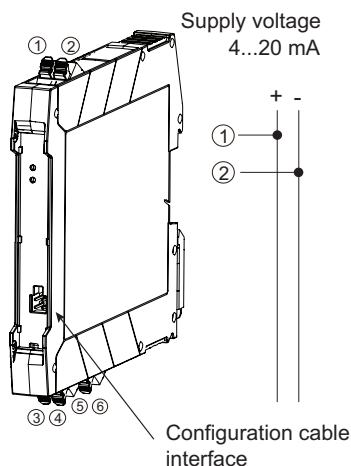
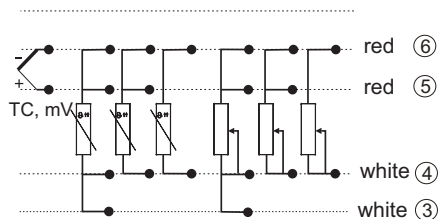

Supply voltage
4...20 mA

Load Impedance

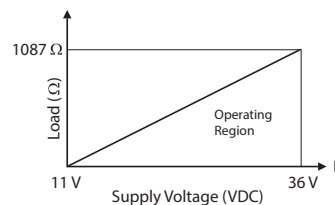

$$R_{Lmax} = (V_{powersupply} - 11V) / 0.023A \text{ (current output)}$$

e.g. $(24V - 11V) / 0.023A = 565.22 \Omega$

* For convenient installation, wiring plugs are removable.

Note: In the event of a thermocouple (TC) measurement, a 2-wire Pt100 RTD can be connected to measure the reference junction temperature. This is connected to terminals 4 and 6.

Dimensions

inches [mm]

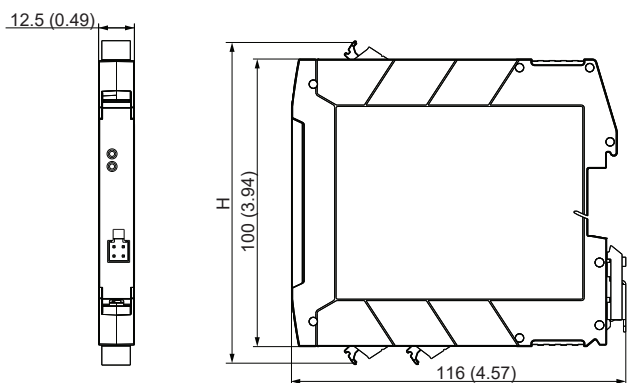

The height of housing H varies depending on the terminal version: screw terminals = 114 mm (4.49 in), push-in terminals = 111.5 mm (4.39 in)

proSense® Temperature Transmitter Configuration Software

Quick and easy configuration with Free XT-SOFT and ProSense Field Device Configurator Software – NO decade box, meters, or signal generators needed!

Overview

XT-SOFT PC software is a utility program that allows users to easily configure ProSense **XTD-0-UNV**, and XTP series temperature transmitters and ETS series digital temperature sensors.

ProSense Field Device Configurator is a utility program that allows users to easily configure, monitor, and retrieve diagnostic information from the ProSense XTH2 and XTD2 series temperature transmitters.

Download your free copy of **XT-SOFT** and ProSense Field Device Configurator at www.AutomationDirect.com and connect your transmitter to the PC through an **XT-USB** configuration cable (purchased separately). An **XT-M12** adapter is also required when connecting to an XTP series transmitter.

XT-SOFT System Requirements:

- Windows 10, 11
- 1 USB 2.0 Port
- 128 MB hard disk space



ProSense Field Device Configurator System Requirements:

- Windows 10, 11
- 1 USB 2.0 Port
- 25 MB hard disk space
- Microsoft .Net Framework ≥4.8
- PDF Reader

XTP Series Configuration Parameters (Requires XT-SOFT):

- Measuring unit (°C/°F)
- Measuring range limits -50 to 150°C (-58 to 302°F)
- Fault condition reaction (≤ 3.6 mA or ≥ 21.0 mA)
- Output (4-20 mA or 20-4 mA)
- Filter (0 to 8s)
- Offset (-9.9 to +9.9 K)
- Measurement point identification/TAG
- Output simulation drives output to a fixed value



XTP Series

XTH & XTD Configuration Parameters: (Requires XT-SOFT)

- Sensor Type:
 - Thermocouple Types J, K, T, E, N, R, S, U, B, C, D, L
 - RTD Types Pt100, Pt500, Pt1000, Pt50, Ni100, Ni120, Ni500, Ni1000
- Linear Resistance 10 to 400 Ohms, 10 to 2000 Ohms
- Millivolts -10 to 100 mV
- Wiring connection 2, 3, or 4-wire (RTD or Linear Resistance only)
- Measuring range start and end points
- Selectable units of °F or °C
- Choose from internal or external cold junction compensation (TC only)
- Wire resistance compensation (2-wire RTD or Linear Resistance only)
- Output action of 4-20 mA or 20-4 mA
- Selectable up scale or down scale signal for sensor lead break or short circuit detection (NAMUR NE43 fault response)
- Adjustable digital filter time constant to compensate for undesirable input fluctuations
- Zero point correction offset factor in °F or °C



XTH Series



XTD Series

proense® Temperature Transmitter Configuration Software

XTH2 & XTD2 Configuration Parameters (Requires Field Device Configurator):

- Sensor Type:
 - Thermocouple Types J, K, T, E, N, R, S, U, B, C, D, L
 - RTD Types Pt100, Pt500, Pt1000, Pt50, Ni100, Ni120, Ni500, Ni1000
 - Linear Resistance 10 to 400 Ohms, 10 to 2000 Ohms
 - Millivolts -20 to 100 mV
 - Wiring connection 2, 3, or 4-wire (RTD or Linear Resistance only)
 - Measuring range start and end points
 - Selectable units of °F, °C, K, Ohm and mV
 - Choose from internal or external cold junction compensation (TC only)
 - Wire resistance compensation (2-wire RTD or Linear Resistance only)
 - Output action of 4-20 mA or 20-4 mA
 - Selectable up scale or down scale signal for sensor lead break or short circuit detection (NAMUR NE43 fault response)
 - Adjustable digital filter time constant to compensate for undesirable input fluctuations
 - Zero point correction offset factor in °F or °C



XTH2 Series



XTD2 Series

ETS Series Configuration Parameters (Requires XT-SOFT):

- Basic Settings:
 - Measuring unit (°C/°F/K)
 - Offset: Configure zero point: ±18°F (±10°C/K)
 - Display - Measured value display
 - Measured value display rotated 180°
 - Set switch point display
 - Set switch point display rotated 180°
 - Display off rotated 180°
 - Damping: display value, output signal: 0 (no damping) to 40s (in increments of 1 second)
 - DESINA® - PIN assignment of the M12 connector is in accordance with the guidelines of DESINA
 - Settings for Switch Output:
 - Switching characteristic - Window/NC contact
 - Hysteresis/NC contact
 - Window/NO contact
 - Hysteresis/NO contact
 - Analog output (if applicable)
 - Switch point value: -57.1 to 302°F (-49.5 to 150°C) in increments of 0.18°F (0.1°C)
 - Switch-back point value: -58 to 300°F (-50 to 149°C) in increments of 0.18°F (0.1°C)
 - Switch point delay: 0 to 99s in increments of 0.1s
 - Switch-back point delay: 0 to 99s in increments of 0.1s
 - Settings for Analog Output (if applicable):
 - Value for 4mA: -58 to 266°F (-50 to 130°C) Lower range value in increments of 0.18°F (0.1°C)
 - Value for 20mA: -22 to 302°F (-30 to 150°C) Upper range value in increments of 0.18°F (0.1°C)
 - Error current - Current value in event of error:
 - Minimum = ≤ 3.6 mA
 - Maximum = ≥ 21.0 mA
 - HOLD = last value
 - Settings for Service Functions:
 - Locking code - Enter the locking code for enabling the device.
 - Change locking code - Freely selectable code 1 to 9999. 0 = no locking
 - Simulation output 1 or 2 - OFF: No simulation
 - OPEN: Switch output open
 - CLOSE: Switch output closed
 - Simulation values for analog output in mA (3.5 / 4.0 / 8.0 / 12.0 / 16.0 / 20.0 / 21.7)



ETS Series

proSense® Temperature Transmitter Configuration Software

proSense®
XT-SOFT



XT-USB



XT-M12

XT-SOFT

Part No.	Description	Pcs/Pkg	Wt(lb)	Price
<u>XT-SOFT</u>	ProSense configuration software, free download. For use with ProSense temperature transmitter XTP series, digital temperature sensor ETS series and models XTH-0-UNV, XTD-0-UNV.	1	N/A	Free Download
<u>Field Device Configurator</u>	ProSense configuration software, free download. For use with ProSense temperature transmitter series XTH2-0-UNV and XTD2-0-UNV.	1	N/A	Free Download
<u>XT-USB</u>	ProSense configuration cable, USB to keyed 4-pin male, 7.9 ft/2.4 m cable length. For use with XT-SOFT and Field Device Configurator software, ProSense temperature transmitter XTP series, digital temperature sensor ETS series and models XTH-0-UNV, XTD-0-UNV, XTH2-0-UNV, and XTD2-0-UNV.	1	0.4	\$110.00
<u>XT-M12</u>	ProSense adapter, keyed 4-pin female to 4-pin M12. For use with ProSense temperature transmitter XTP series and XT-USB cable.	1	0.1	\$18.50

Connection Examples

XTH2-0-UNV Connection (Requires Field Device Configurator)

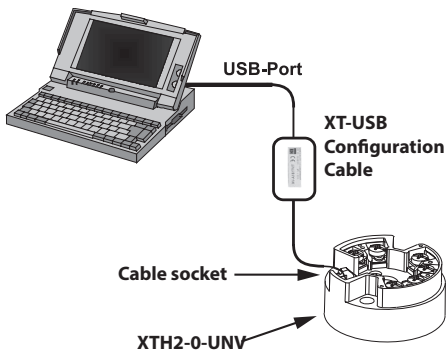

XTD2-0-UNV Connection (Requires Field Device Configurator)

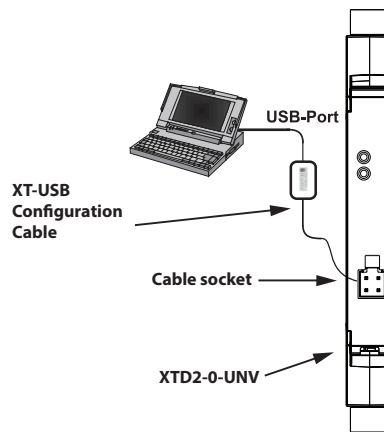

XTP Series Connection (Requires XT-SOFT)

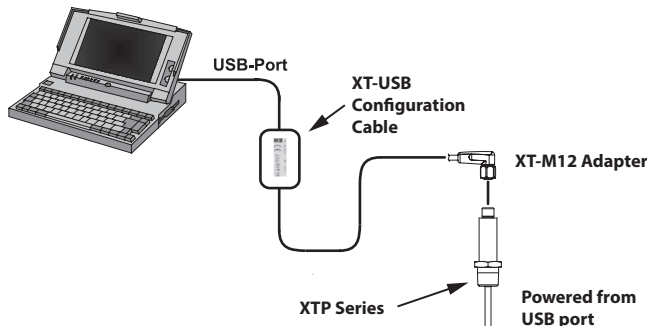

Note: XT-SOFT version 1.27.13.0 or later required for use with the XTP series transmitters

ETS Series Connection (Requires XT-SOFT)

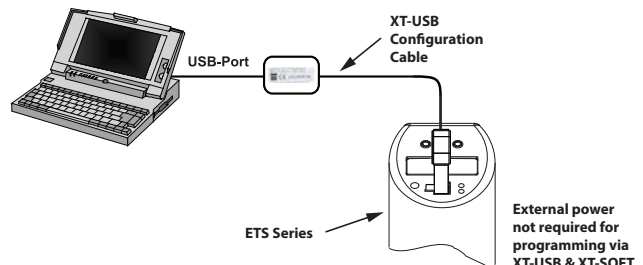

Note: XT-SOFT version 1.27.15.0 or later required for use with the ETS Series.



Scan the QR Code or click to view the help file for the XT-SOFT software.



Scan the QR Code or click to view the help file for the ProSense Field Device Configurator software.