



# EchoPod/EchoTouch<sup>®</sup> Reflective Technology<sup>™</sup> Ultrasonic Liquid Level Sensors



## Overview

The innovative EchoPod/EchoTouch Reflective Technology ultrasonic liquid level sensors replace other ultrasonic level sensors in condensation applications, as well as float, conductance and pressure sensors that fail due to contact with dirty, sticky and scaling media in small, medium and large capacity tanks. Applied in chemical, water and wastewater applications, these general purpose or intrinsically safe non-contact sensors are available with single and multi-function capabilities, including continuous level measurement, switching and control. The standard 4-20 mA output is easily monitored by a PLC or other controller. Models with four relays can be configured for level alarms and/or stand-alone level control such as automatic fill or empty functions using the embedded level controller. PC configuration of all models is simple with **WEBCAL<sup>™</sup>** software, while the UG06, UG12 and US06 models also offer limited configuration via their pushbuttons and integral display.



## What is Reflective Technology<sup>™</sup>?

Condensation is the most commonly encountered variable in liquid level applications. Condensation attenuates the acoustic signal of ultrasonic sensors that have a flat horizontal transducer face, weakening their signal strength and signal-to-noise ratio by up to 50%, and substantially reducing their measurement reliability. At the core of Reflective Technology<sup>™</sup> is a simple fact: unlike flat horizontal surfaces, significant water droplets cannot adhere to smooth vertical surfaces. By orienting the internal ultrasonic transducer vertically, condensation runs off the transducer face and does not affect sensor performance. The unimpeded transmit and receive signals are redirected to and from the liquid off a 45° reflector, delivering reliable level measurement. Thanks gravity!



## Reflective Technology

Horizontal Transducer

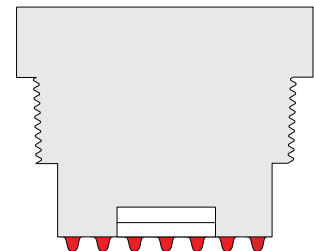

Signal Attenuation

Reflective Transducer

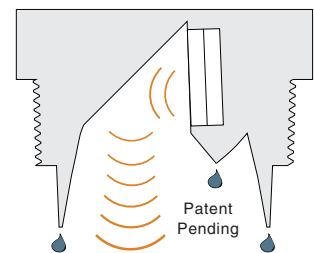

Reliable Measurement

## WebCal Software



WEBCAL



L199-2001

**WEBCAL** PC software is a utility program that enables users to easily configure their EchoSonic II, EchoTouch and EchoPod level transmitters, switches, and controllers. Download your free copy of WebCal at [www.AutomationDirect.com](http://www.AutomationDirect.com), and connect your sensor through our Fob USB adapter (L199-2001). Develop your configuration using pre-programmed function menus as the tank graphic and set point fields automatically change to match your configuration. Then, input your level set point values and click the Write to Unit button. Your configuration will be downloaded into the sensor and verified in less than a second. Last, click the Wiring Diagram button to open a wiring schematic of your configuration in PDF format. Print the document, disconnect the sensor and wire it per the schematic. As new software or firmware becomes available, it can be downloaded and updated through WebCal.



# EchoPod/EchoTouch<sup>®</sup> Reflective Technology<sup>™</sup> Ultrasonic Liquid Level Sensors

EchoPod/EchoTouch Reflective Technology Ultrasonic Liquid Level Sensors General Specifications							
Model	<u>UG01-0001-40</u>	<u>UG03-0001-40</u>	<u>UG06-0001-00</u>	<u>UG12-0001-00</u>	<u>US01-0001-00</u>	<u>US03-0001-00</u>	<u>US06-0001-00</u>
Price	\$525.00	\$600.00	\$800.00	\$1,050.00	\$645.00	\$715.00	\$1,000.00
Type	EchoPod/EchoTouch Reflective Technology (works in condensing environments)						
Classification	General purpose (non-hazardous)				Intrinsically safe		
Media	Liquids						
Range	1.5 in to 4.9 ft (3.8 cm to 1.5 m)	4in to 9.8 ft (10.1 cm to 3m)	8in to 19.6 ft (20cm to 6m)	18in to 39.3 ft (45.7 cm to 12m)	1.5 in to 4.9 ft (3.8 cm to 1.5 m)	4in to 9.8 ft (10.1 cm to 3m)	8in to 19.6 ft (20cm to 6m)
Output	4-20 mA and (4) SPST relays			4-20 mA (No Relays)			
Mounting	Vertical, top of tank, 2in NPT male			Vertical, top of tank, 3in NPT male	Vertical, top of tank, 2in NPT male		
Electrical Termination	Integral 48in, 9-conductor, shielded cable		Screwless terminals, 1/2in female NPT		Integral 48in, 4-conductor, shielded cable		Screwless terminals, 1/2in female NPT
Configuration	<u>WEBCAL</u> Software (free download) and LI99-2001 Fob USB Adapter (purchased separately)		<u>WEBCAL</u> Software (free download) and LI99-2001 Fob USB Adapter (purchased separately) or Pushbutton / LCD		<u>WEBCAL</u> Software (free download) and LI99-2001 Fob USB Adapter (purchased separately)		<u>WEBCAL</u> Software (free download) and LI99-2001 Fob USB Adapter (purchased separately) or Pushbutton / LCD
Ambient Temperature	-31° to 140°F (-35° to 60°C)						-40° to 176°F (-40° to 80°C)
Process Temperature	-40° to 176°F (-40° to 80°C)						
Pressure	30 PSI (2 bar) max.						



# EchoPod® UG06 & UG12 Series Ultrasonic Liquid Level Sensors

Part No. [UG06-0001-00](#) ShownPart No. [UG12-0001-00](#) Shown

## UG06 & UG12 Technical Specifications

Model	<a href="#">UG06-0001-00</a>	<a href="#">UG12-0001-00</a>
Price	\$800.00	\$1,050.00
Weight (lbs)	1.9	2.5
Range	8in to 19.6 ft (20cm to 6m)	18in to 39.3 ft (45.7 cm to 12m)
Accuracy	±0.2% of range	
Resolution	0.079 in (2mm)	0.196 in (5mm)
Sensing Dead Band*	8in (20.3 cm)	18in (45.7 cm)
Beam Width	3in (7.6 cm)	6in (15.2 cm)
Configuration**	Pushbutton or <a href="#">WEBCAL</a> ® PC Windows® USB® 2.0	
Memory	Non-volatile	
Display Type	LCD, 6-digit	
Display Units	Inch, cm or percent	
Supply Voltage	14-28 VDC	
Max. Consumption	0.5 W	
Loop Resistance	500Ω @ 24VDC	
Signal Output	4-20 mA, two-wire	
Signal Invert	4-20 mA or 20-4 mA	
Signal Fail-Safe	4mA, 20mA, 21mA, 22mA, hold last	
Process Temperature	-40° to 176°F (-40° to 80°C)	
Temp. Compensation	Automatic	
Ambient Temperature	-31° to 140°F (-35° to 60°C)	
Pressure	30 PSI (2 bar)	
Enclosure Rating	Type 6P (IP68)	
Enclosure Material	Polypropylene (PP)	
Enclosure Cap Material	Clear Polycarbonate (PC)	
Enclosure Vent	Water tight membrane	
Conduit Entrance	1/2 in NPT	
Transducer Type	Reflective	
Transducer Material	Polyvinylidene fluoride (PVDF)	
Process Mount	2in Male NPT	3in Male NPT
Classification	General purpose	
Compliance	CSA certified to UL 61010-1	
Agency Approvals	CSA, CE	

\* Dead band is the minimum distance the sensor must be mounted above the max liquid level.

\*\* Some configuration options, such as volumetric mode, only available through [Web-Cal](#). See manual for more configuration options.

## Overview

The EchoPod UG06 and UG12 general-purpose reflective ultrasonic level transmitters provide continuous level measurement up to 39.3' (12m) with a 4-20 mA analog signal output, and is configured via [WEBCAL](#) software with limited configuration also available via the integral pushbutton display module. The non-contact liquid level sensor features Flowline's proprietary Reflective Technology™ that delivers reliable level measurement in condensing environments. Select this sensor for bulk tanks with non-foaming and mildly vaporous media such as chemicals, water, wastewater and oil. Typical applications include bulk storage, neutralization tank, clarifier and waste sumps.

## Features

- 6m (19.6') and 12m (39.3') measurement ranges
- Reflective Technology™ measures reliably with condensation
- Corrosion resistant PVDF transducer with IP68 PP enclosure
- Fail-safe diagnostics with selectable signal fail-safe outputs
- LCD display indicates level in inches, feet, or meters
- Narrow 3" (7.6cm) (UG06) or 6" (15.2cm) (UG12) beam width for applications with limited space
- Windowed enclosure cap provides liquid tight level indication
- Configuration via [WEBCAL](#) software with limited configuration via the integral pushbutton and display
- Automatic temperature compensation from -40° to 176°F (-40° to 80°C)
- 2-year warranty

## Agency Approvals

- CSA, CE



## Configuration

The settings for the UG06 and UG12 are configured with free [WEBCAL](#) software (downloadable from AutomationDirect Web site), and an [LI99-2001](#) Fob USB adapter (purchased separately).

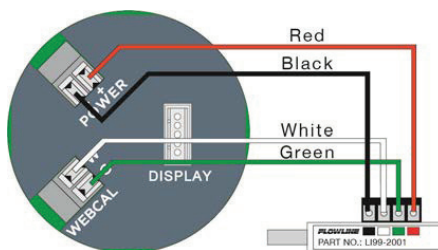
[LI99-2001](#)

Note: Remove the display from the housing and disconnect the cable from the connector before wiring the Fob.

See the end of the Ultrasonic Level Sensor Section for further details and Accessories



# Ultrasonic Liquid Level Sensor Accessories

Ultrasonic Liquid Level Sensor Accessories					
Part No.	Item Photo	Description	Quantity	Weight	Price
<a href="#">LI40-1001</a>		Flowline PodView general purpose digital indicator, displays tank level or volume and sensor relay status, 6-digit LCD display with four relay status indicators, 3-button user interface, polycarbonate panel mount enclosure with NEMA 4 (IP65) faceplate, 6-foot (1.8-meter) 22AWG 4-conductor cable, for use with Flowline EchoPod DL, DS and DX series ultrasonic level sensor with firmware V50.0 or later	1	0.6	\$275.00
<a href="#">LM50-1001</a>		Flowline side mount bracket, 2 inch NPT female threads, polypropylene (PP), for use with Flowline DL34, LU23, LU28, LU29, LU74, LU78, LU81, LU83, LU84, UG01, UG03, UG06, US01, US03 and US06 series ultrasonic level sensors	1	0.4	\$48.00
<a href="#">LM50-1001-1</a>		Flowline side mount bracket, 2 inch NPT female threads, polypropylene (PP), and 2 inch NPT male x 1 inch NPT female reducer bushing (PVC), for use with Flowline DL14, DL24, DS14, DL10, DX10, LU27, LU77 and LU80 series ultrasonic level sensors	1	0.6	\$64.00
<a href="#">LM52-1400</a>		Flowline reducer bushing, 2 inch NPT male x 1 inch NPT female threads, PVC, for use with Flowline DL14, DL24, DS14, DL10, DX10, LU27, LU77 and LU80 series ultrasonic level sensors	1	0.2	\$18.00
<a href="#">LM52-2400</a>		Flowline reducer bushing, 3 inch NPT male x 2 inch NPT female threads, PVC, for use with Flowline DL34, LU23, LU28, LU29, LU74, LU78, LU81, LU83, LU84, UG01, UG03, UG06, US01, US03 and US06 series ultrasonic level sensors	1	0.6	\$46.00
<a href="#">LM52-3800</a>		Flowline reducer bushing, PVC, 4in male NPT to 2in female NPT. For use with Flowline DL34, LU23, LU28, LU29, LU74, LU78, LU81, LU83, LU84, UG01, UG03, UG06, US01, US03 and US06 series ultrasonic level sensors	1	2.0	\$156.00
<a href="#">LM52-1890</a>		Flowline low-profile bulkhead fitting, 1 inch NPT female x slip socket, with mounting nut, PVC, for use with Flowline DL14, DL24, DS14, DL10, DX10, LU27, LU77 and LU80 series ultrasonic level sensors	1	0.5	\$60.00
<a href="#">LM52-2890</a>		Flowline low-profile bulkhead fitting, 2 inch NPT female x slip socket, with mounting nut, PVC, for use with Flowline DL34, LU23, LU28, LU29, LU74, LU78, LU81, LU83, LU84, UG01, UG03, UG06, US01, US03 and US06 series ultrasonic level sensors	1	1.2	\$114.00
<a href="#">LM52-3890</a>		Flowline low-profile bulkhead fitting, PVC, 3in female NPT to slip socket. For use with Flowline UG12 series ultrasonic level sensors. Mounting hardware included.	1	2.1	\$194.00
<a href="#">LM52-1850</a>		Flowline mounting flange, 1 inch NPT female threads, CPVC, for use with Flowline DL14, DL24, DS14, DL10, DX10, LU27, LU77 and LU80 series ultrasonic level sensors	1	0.5	\$92.00
<a href="#">LM52-2850</a>		Flowline mounting flange, 2 inch NPT female threads, CPVC, for use with Flowline DL34, LU23, LU28, LU29, LU74, LU78, LU81, LU83, LU84, UG01, UG03, UG06, US01, US03 and US06 series ultrasonic level sensors	1	1.0	\$140.00
<a href="#">LM52-3850</a>		Flowline mounting flange, CPVC, 3in female NPT. For use with Flowline UG12 series ultrasonic level sensors.	1	1.9	\$280.00
<a href="#">204038</a>		Replacement mounting gasket, for use with Flowline DL14, DL10, DX10 and DS14 series ultrasonic level sensors	1	0.1	\$8.00
<a href="#">200128</a>		Replacement mounting gasket, for use with Flowline DL24, LU27, LU77 and LU80 series ultrasonic level sensors	1	0.1	\$12.00
<a href="#">200129</a>		Replacement mounting gasket, for use with Flowline DL34, LU23, LU28, LU29, LU74, LU78, LU81, LU83 and LU84 series ultrasonic level sensors	1	0.1	\$18.00

When installing the 1" NPT level sensors care should be used to mechanically isolate the sensor housing from the tank. This can easily be done by using any of the Flowline mounting accessories which are designed to provide the isolation needed.



# EchoPod® UG06 & UG12 Series Ultrasonic Liquid Level Sensors

## Wiring

Common wiring to display, controllers and PLC examples

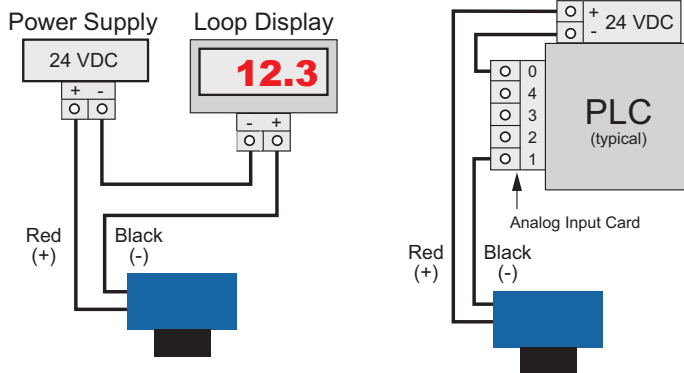

## Dimensions inches [mm]

Part No. [UG06-0001-00](#)

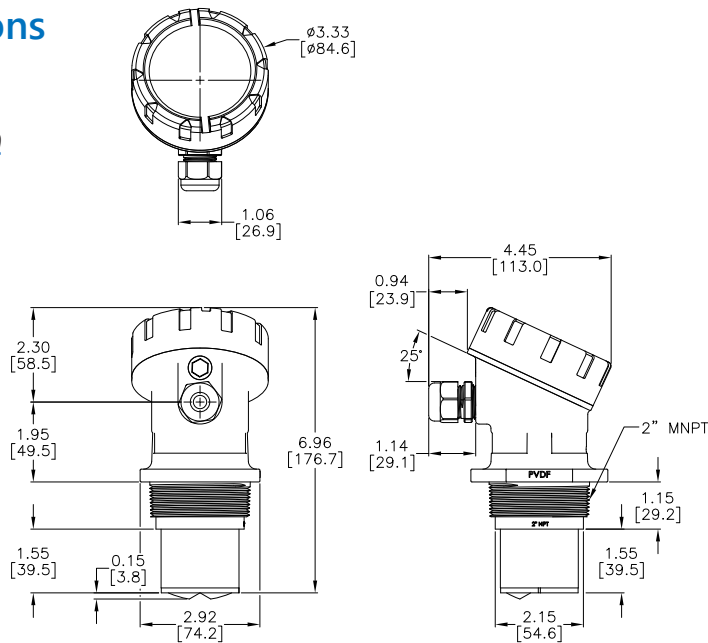

Part No. [UG12-0001-00](#)

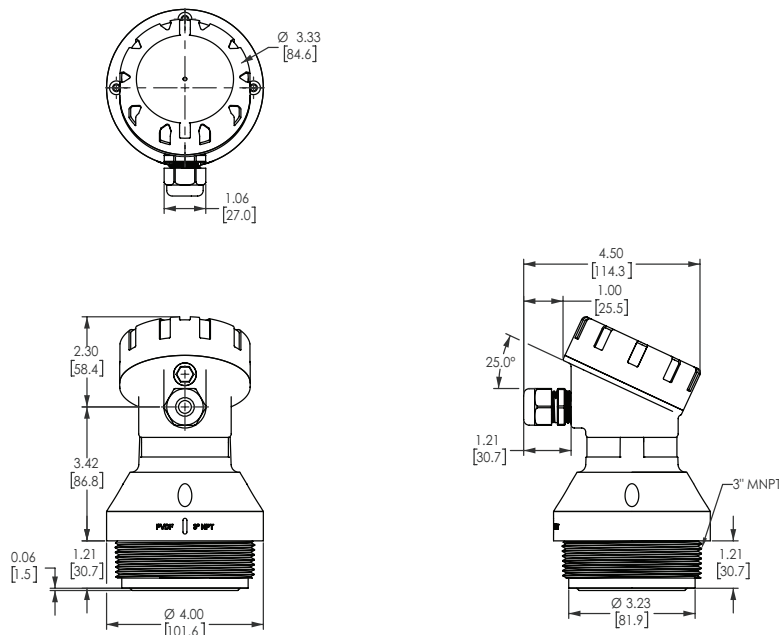

See our website [www.AutomationDirect.com](http://www.AutomationDirect.com) for complete Engineering drawings.



# Ultrasonic Liquid Level Sensor Accessories

## Dimensions

inches [mm]

### LM50-1001

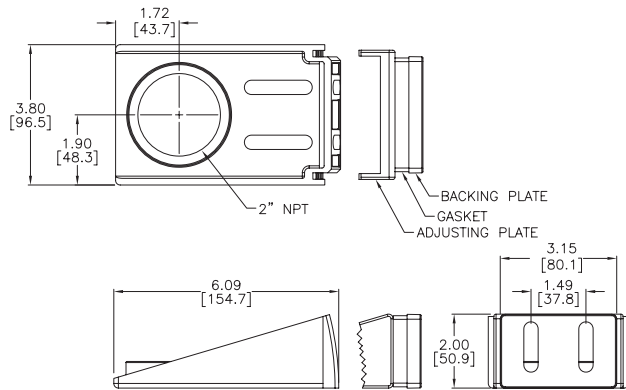

### LM50-1001-1

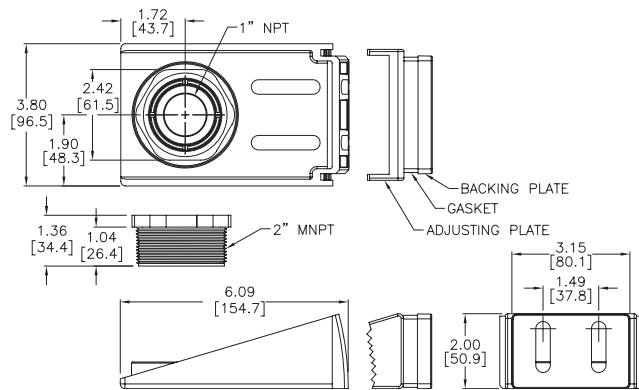

### LM52-1400

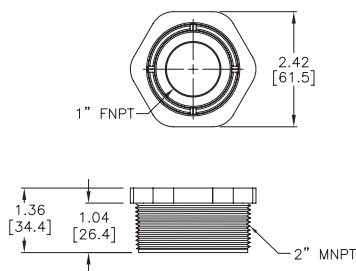

### LM52-2400

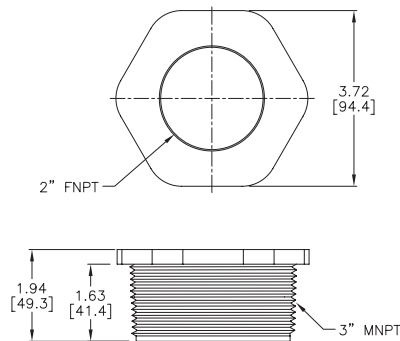

### LM52-3800

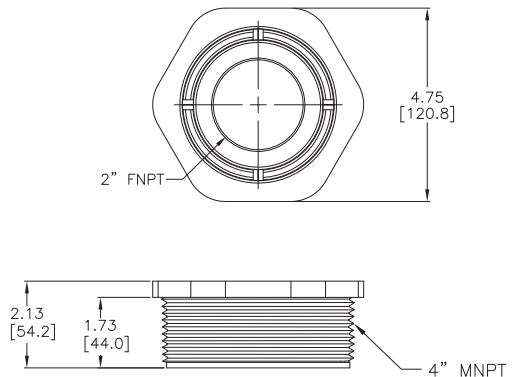

### LM52-1890

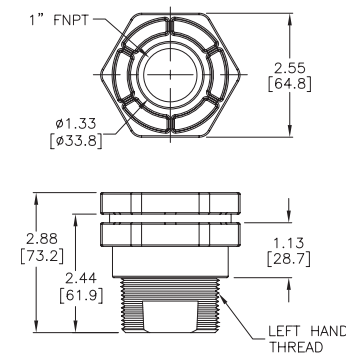

### LM52-2890

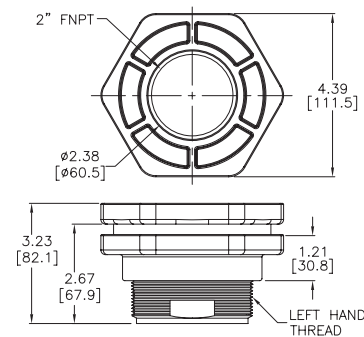

### LM52-3890

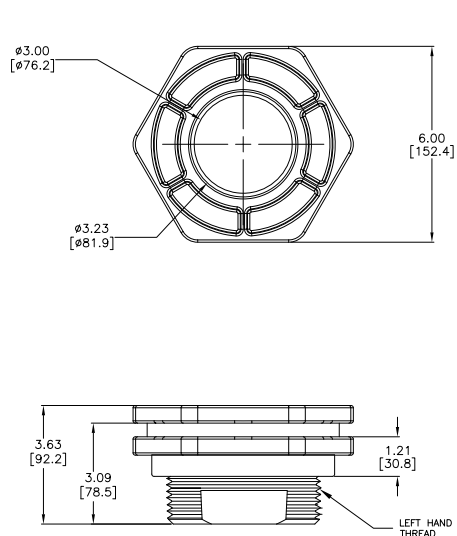

See our website [www.AutomationDirect.com](http://www.AutomationDirect.com) for complete Engineering drawings.



# Ultrasonic Liquid Level Sensor Accessories

## Dimensions

inches [mm]

### LM52-1850

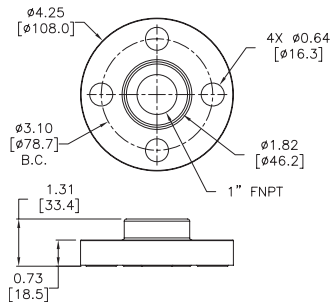

### LM52-2850

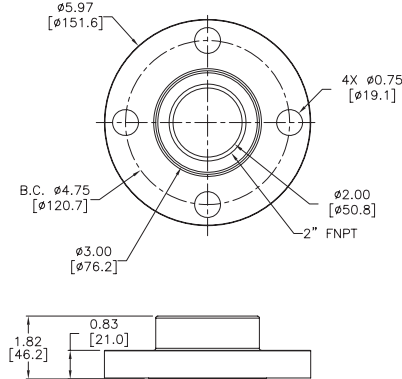

### LM52-3850

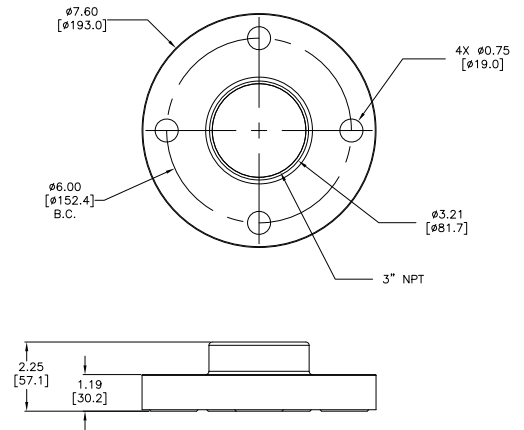

See our website [www.AutomationDirect.com](http://www.AutomationDirect.com) for complete Engineering drawings.



# WebCal Ultrasonic Level Sensor Software and USB Fob Adapter



## Overview

**WEBCAL** PC software is a utility program that allows users to easily configure their EchoPod, EchoTouch and EchoSonic II level transmitters, switches, and controllers. Download your free copy of **WEBCAL** at [www.AutomationDirect.com](http://www.AutomationDirect.com), and connect your sensor through the Fob USB adapter ([LI99-2001](#)). Develop your configuration using pre-programmed function menus as the tank graphic and set point fields automatically change to match your configuration. Then, input your level set point values and click the Write to Unit button. Your configuration will be downloaded into the sensor and verified in less than a second. Last, click the Wiring Diagram button to open a wiring schematic of your configuration in PDF format. Print the document, disconnect the sensor and wire it per the schematic. It's that simple.

Configuration files can be named, saved, emailed, printed, opened and used again under revision control. The advanced feature page enables you to change the measurement signal, output filtering and invert relay states from N.O. to N.C. As new software or firmware becomes available, they can be downloaded and updated through **WEBCAL**.

## Features

- 169 configurations with pull-down menu selections
- Graphical interface lets you visualize your configuration
- Applicable level set point fields appear automatically
- Installs and tests configuration in less than a second
- Available PDF wiring diagram for each configuration
- Technical help menu with FAQs, tips and glossary
- Rapidly program sensors to the same configuration
- Save configuration files for future use or reference
- Print wiring diagrams and configuration text files
- Email configuration files to other remote users
- Please check [www.automationdirect.com](http://www.automationdirect.com) for the most recent system requirements.

WebCal Ultrasonic Level Sensor Software and USB Adapter					
Part No.	Item Photo	Description	Quantity	Weight (lbs)	Price
<a href="#">LI99-2001</a>		Flowline Fob USB adapter, required for use with WebCal software to configure Flowline EchoPod, EchoTouch and EchoSonic II ultrasonic level sensors.	1	0.1	\$65.00
<a href="#">WEBCAL</a>		Configuration software for Flowline EchoPod, EchoTouch and EchoSonic II ultrasonic level sensors. Requires an <a href="#">LI99-2001</a> Fob USB adapter (purchased separately).	1	0.1	Free Download

## EchoPod Configuration

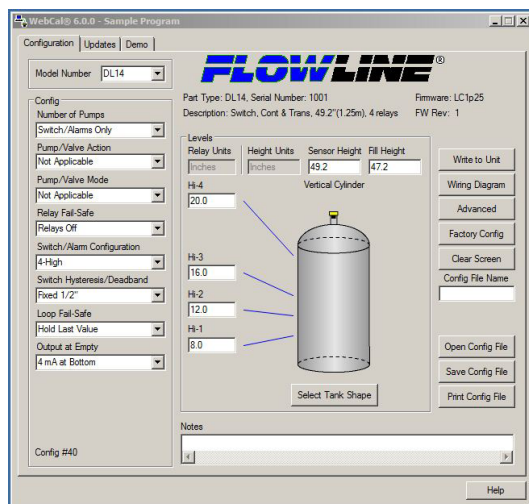

## EchoSonic II Configuration

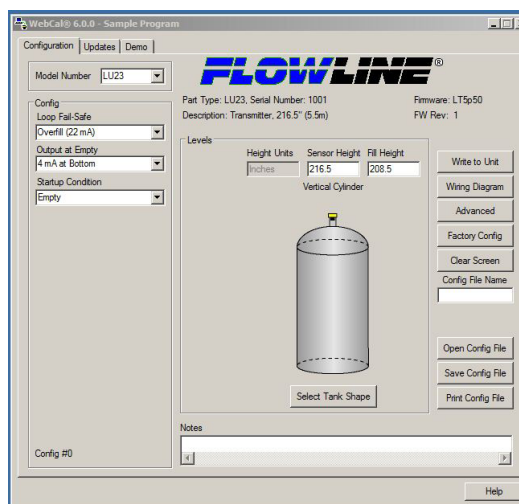

Click on the thumbnail or go to <https://www.automationdirect.com/VID-LE-0004> for Part 1 of our How To video on the use of the Flowline Ultrasonic Level Sensors

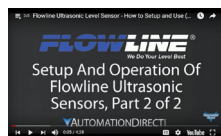

Click on the thumbnail or go to <https://www.automationdirect.com/VID-LE-0005> for Part 2 of our How To video on the use of the Flowline Ultrasonic Level Sensors