

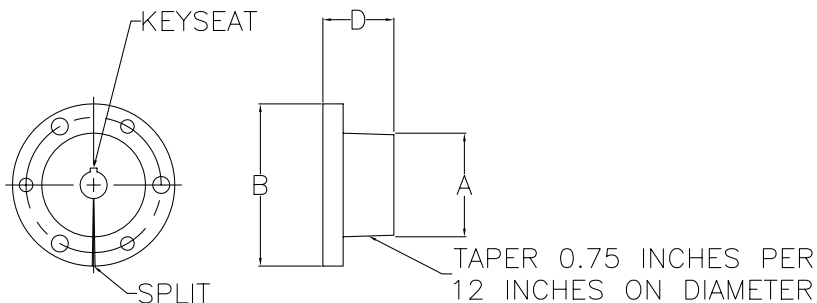

# Synchronous Drive Components

## QD®\* Style Bushings



QD® Bushings														
Part Number	Price	Weight (lb)	Series	Torque Capacity (lb-in)	Bore Size (in)		Keyway (in)	Dimensions (in)			Bolt Circle (in)	Cap Screws		Material*
					Nominal	Max. with Shallow Keyseat		A	B	D		#	Size	
<a href="#">QD-JA-0500</a>	\$20.50	0.5	JA	1750	0.500	1-1/4	1/8	1.375	2.0	1.0	1.6563	3	#10 x 1	S
<a href="#">QD-JA-0625</a>	\$19.00	0.5		1750	0.625	1-1/4	3/16	1.375	2.0	1.0	1.6563	3	#10 x 1	S
<a href="#">QD-JA-0750</a>	\$19.00	0.4		1750	0.750	1-1/4	3/16	1.375	2.0	1.0	1.6563	3	#10 x 1	S
<a href="#">QD-JA-0875</a>	\$19.00	0.4		1750	0.875	1-1/4	3/16	1.375	2.0	1.0	1.6563	3	#10 x 1	S
<a href="#">QD-SH-0500</a>	\$27.50	1.3	SH	3500	0.500	1-5/8	1/8	1.871	2.6875	1.25	2.25	3	1/4 x 1-3/8	S
<a href="#">QD-SH-0625</a>	\$27.50	1.2		3500	0.625	1-5/8	3/16	1.871	2.6875	1.25	2.25	3	1/4 x 1-3/8	S
<a href="#">QD-SH-0750</a>	\$27.50	1.2		3500	0.750	1-5/8	3/16	1.871	2.6875	1.25	2.25	3	1/4 x 1-3/8	S
<a href="#">QD-SH-0875</a>	\$27.50	1.2		3500	0.875	1-5/8	3/16	1.871	2.6875	1.25	2.25	3	1/4 x 1-3/8	S
<a href="#">QD-SH-1000</a>	\$27.50	1.1		3500	1.000	1-5/8	1/4	1.871	2.6875	1.25	2.25	3	1/4 x 1-3/8	S
<a href="#">QD-SDS-0625</a>	\$34.00	1.8	SDS	5000	0.625	1-15/16	3/16	2.1875	3.1875	1.3125	2.6875	3	1/4 x 1-3/8	S
<a href="#">QD-SDS-0750</a>	\$34.00	1.8		5000	0.750	1-15/16	3/16	2.1875	3.1875	1.3125	2.6875	3	1/4 x 1-3/8	S
<a href="#">QD-SDS-0875</a>	\$34.00	1.8		5000	0.875	1-15/16	3/16	2.1875	3.1875	1.3125	2.6875	3	1/4 x 1-3/8	S
<a href="#">QD-SDS-1000</a>	\$34.00	1.6		5000	1.000	1-15/16	1/4	2.1875	3.1875	1.3125	2.6875	3	1/4 x 1-3/8	S
<a href="#">QD-SDS-1125</a>	\$34.00	1.5		5000	1.125	1-15/16	1/4	2.1875	3.1875	1.3125	2.6875	3	1/4 x 1-3/8	S
<a href="#">QD-SD-0750</a>	\$39.50	2.2	SD	5000	0.750	1-15/16	3/16	2.1875	3.1875	1.8125	2.6875	3	1/4 x 1-7/8	S
<a href="#">QD-SD-0875</a>	\$39.50	2.1		5000	0.875	1-15/16	3/16	2.1875	3.1875	1.8125	2.6875	3	1/4 x 1-7/8	S
<a href="#">QD-SD-1000</a>	\$39.50	2.0		5000	1.000	1-15/16	1/4	2.1875	3.1875	1.8125	2.6875	3	1/4 x 1-7/8	S
<a href="#">QD-SD-1125</a>	\$39.50	1.9		5000	1.125	1-15/16	1/4	2.1875	3.1875	1.8125	2.6875	3	1/4 x 1-7/8	S
<a href="#">QD-SD-1250</a>	\$39.50	1.8		5000	1.250	1-15/16	1/4	2.1875	3.1875	1.8125	2.6875	3	1/4 x 1-7/8	S

\*QD® is a registered trademark of Emerson Electric.

\* S = Steel

Note: Stock bore sizes shown. Bushings may be re-bored up the maximum size listed. Maximum bores may require a shallow keyway and rectangular key.

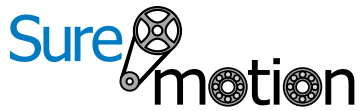

# Synchronous Drive Components

## Timing (Toothed) Belts

SureMotion timing belts are an excellent choice for many industrial applications. Several pitches and widths are available to cover a wide range of power transmission requirements.

- Neoprene with fiberglass reinforcement
- Polyurethane with polyester reinforcement (MXL pitch only)
- MXL (Mini Xtra Light) pitch = 0.080"
- XL (Xtra Light) pitch = 0.200"
- L (Light) pitch = 0.375"
- Range from 30 - 160 teeth
- 0.25, 0.375, 0.50 and 1.0-inch widths
- Timing belts start at \$3.50 (60XL025NG)

## Timing Pulleys

Both aluminum and steel pulleys (sprockets) are available with a smooth bore and setscrew. Steel pulleys also available to fit Taper-Lock or QD style drive bushings. Bushings sold separately.

- Aluminum, steel, cast iron, or ductile iron
- MXL pitch = 0.080" with 1/4" width
- XL pitch = 0.200" with 1/4 or 3/8 inch width
- L pitch = .375" with 1/2 or 1 inch width
- Plain bores and TL or QD type bore
- Timing pulleys start at \$12.50 (APB10XL025BF-250)

## Tapered Drive Bushings

Bushings allow the connection of pulleys to different sized shafts.

- TL (Taper-Lock) and QD (quick detach) types are available
- Steel
- Standard bore sizes from 0.50 to 1.375 inch
- Taper-Lock® bushings start at \$25.00 (TL-1108-0500)
- QD® style bushings start at \$20.50 (QD-JA-0500)

*"Taper-Lock" is a registered trademark of Reliance Electric  
"QD" is a registered trademark of Emerson Electric*





# Synchronous Drive Components

## Product Overview



**Timing Pulleys**



**Bushings**



**Timing Belts**

Timing pulleys, bushings, and belts allow you to change speed and torque while connecting mechanically rotating components.

- Select pulley sizes in order to accomplish the speed or torque change that you need.
- Bushings allow you to connect the same pulleys to different sized shafts, or vice versa.
- Synchronous drive belts and pulleys utilize teeth to prevent slippage and unwanted speed variations.

*Note: For pulley speeds in excess of 6,000 RPM, pulleys should be dynamically balanced.*

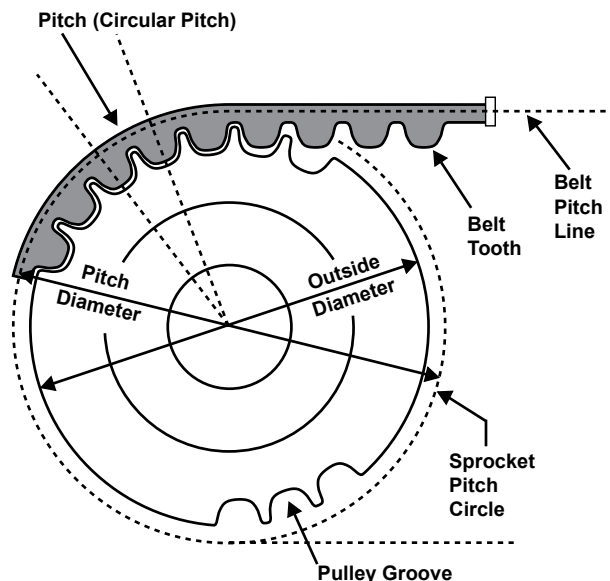

## Drive Component Selection

1. Determine required torque (ft-lbs) and rpm of driven shaft.
2. Determine design horsepower:

$$DHP = \frac{T \cdot N \cdot sf}{5,252}$$

Where: T = torque (ft·lb)  
 N = rpm  
 sf = service factor per table

Service Factors			
Machine Type	<8hr per day	8-16 hr per day	Continuous
Smooth Running	1.0	1.2	1.4
Light Shock Loads	1.3	1.5	1.7
Heavy Shock Loads	1.7	1.9	2.1

3. Determine Pitch (MXL XL or L) and belt width required by reading Design Horsepower Chart.
4. Select driver and driven pulleys to match desired speed or torque change.
5. Determine belt length per belt length calculation.

*Note: AutomationDirect provides an online configuration tool to assist with pulley and belt sizing.  
 See: [www.automationdirect.com/selectors/beltandpulley](http://www.automationdirect.com/selectors/beltandpulley)*



# Synchronous Drive Components

## Design Horsepower Chart

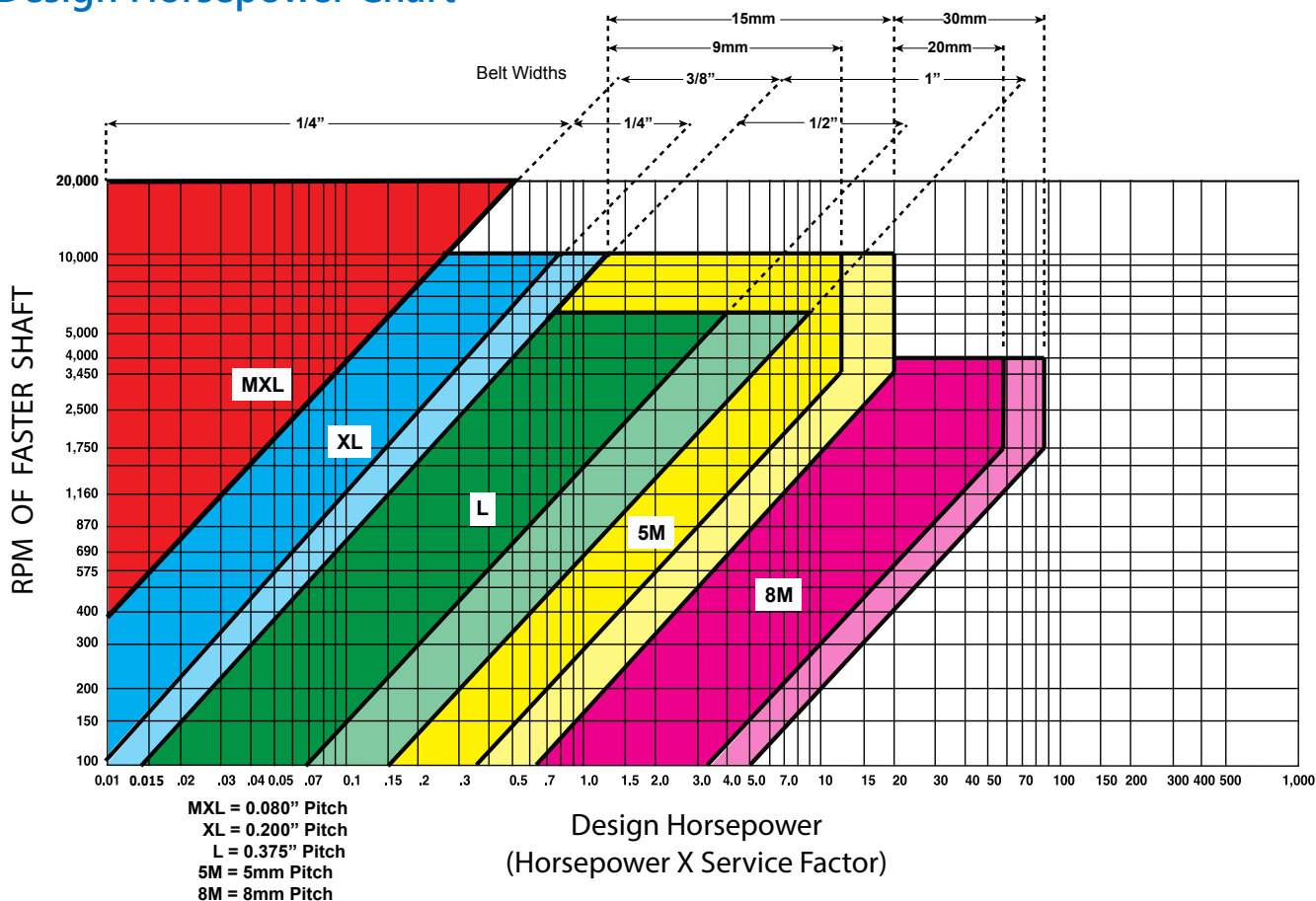

## Drive Component Selection Continued

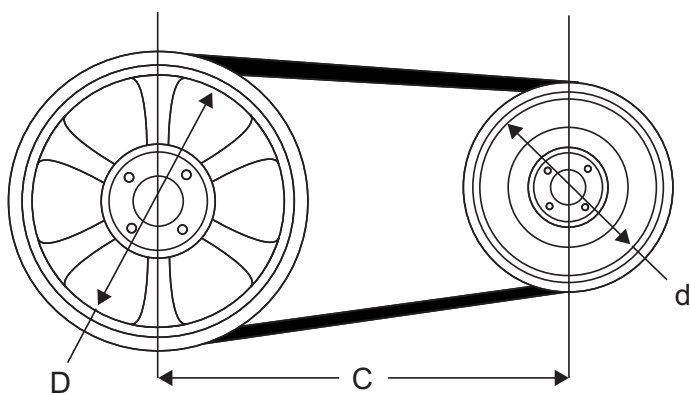

### Belt Length Calculations

$$L = 2C + 1.57 (D + d) + \frac{(D-d)^2}{4C}$$

Where:

- L = Length of belt at pitch line (in inches)
- C = Center distance (in inches)
- D = Pitch diameter (in inches) of large sprocket
- d = Pitch diameter (in inches) of small sprocket