

Standard wiring examples

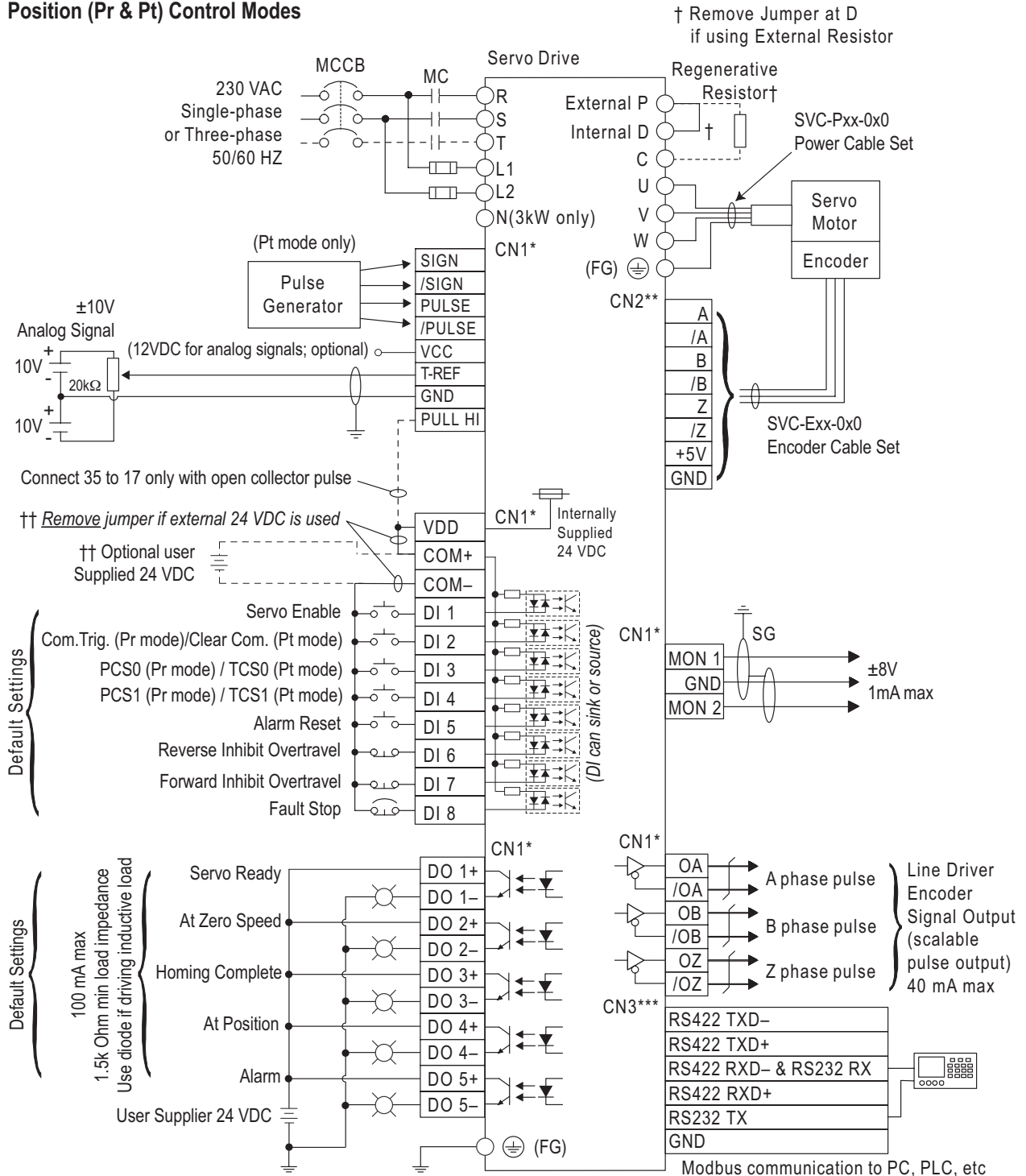

This wiring diagram shows basic wiring only, and additional wiring configurations are possible for some I/O. Refer to the "Installation and Wiring" chapter of the User Manual for more detailed wiring information.

Position (Pr & Pt) Control Modes



* Use connection kit part #s ZL-RTB50 & ZL-SVC-CBL-50(-x) for CN1 terminal connections.
 ** Use cable part # SVC-Exx-0x0 for CN2 terminal connections.
 *** Use cable part # SVC-MDCOM-CBL for CN3 terminal Modbus network connections.



AC Servo System Wiring

Standard wiring examples (continued)



This wiring diagram shows basic wiring only, and additional wiring configurations are possible for some I/O. Refer to the "Installation and Wiring" chapter of the User Manual for more detailed wiring information.

Velocity and Torque Control Modes

† Remove Jumper at D if using External Resistor

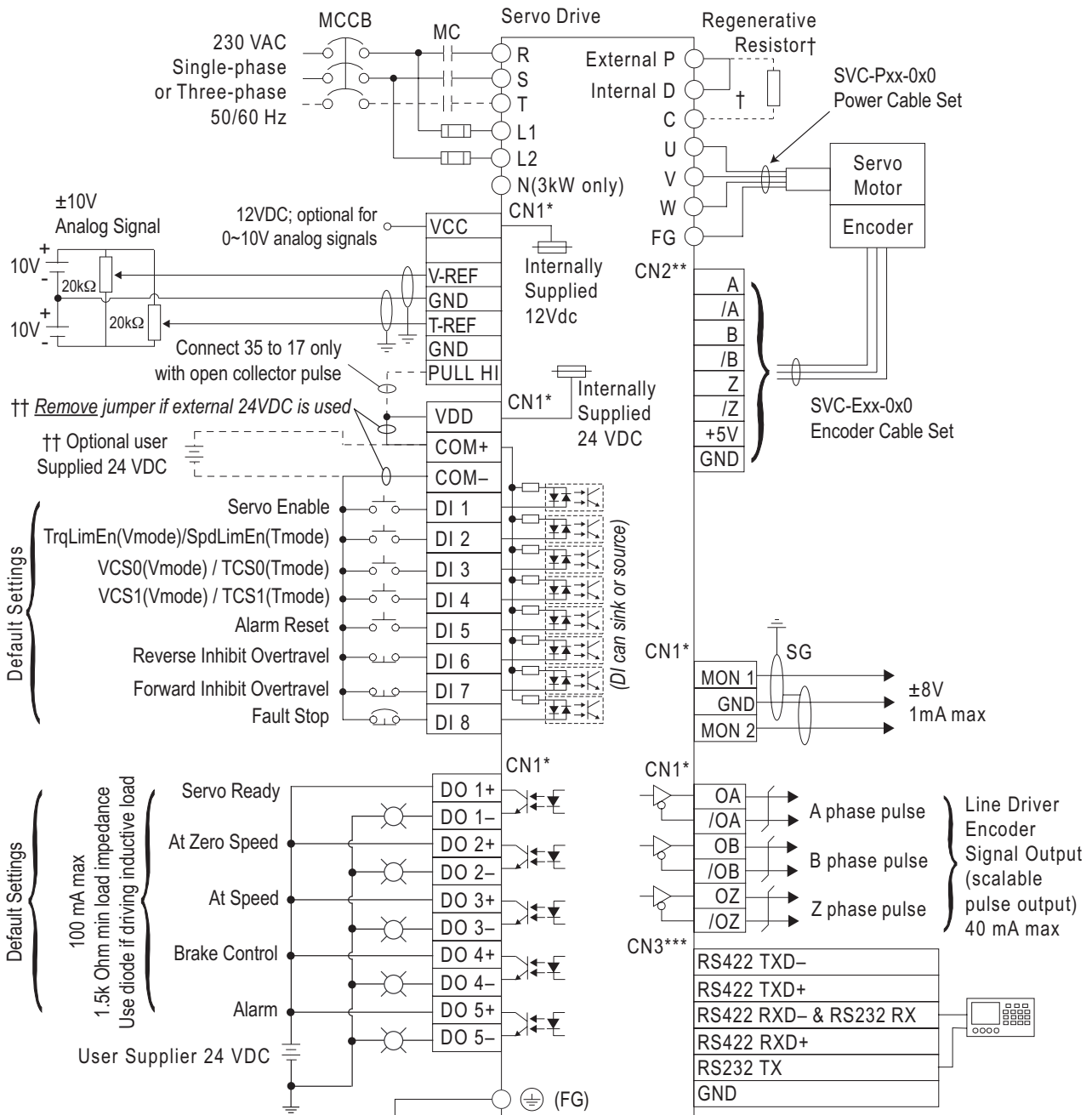

* Use connection kit part #s ZL-RTB50 & ZL-SVC-CBL-50(-x) for CN1 terminal connections.

** Use cable part # SVC-Exx-0x0 for CN2 terminal connections.

*** Use cable part # SVC-MDCOM-CBL for CN3 terminal Modbus network connections.