



AC Servo Systems

Drive features

- Power:
 - 1 phase 110VAC: 100W-2kW
 - 1 phase 220VAC: 100W-2kW
 - 3 phase 220VAC: 100W-15kW
 - 3 phase 460VAC: 400W-15kW
- Fully digital with up to 3.1 kHz bandwidth velocity loop response
- Easy setup and diagnostics with built-in keypad/display or the SureServo2 Pro PC-based software
- Field upgradeable firmware ensures the drive can always be upgraded to the latest operating system
- Communications include:
 - Serial Modbus (native/built-in)
 - Optional Modbus TCP card
 - Optional Ethernet/IP card (this card can use implicit and explicit messaging. SureServo2 Pro software can generate an EDS file to transfer custom data between PLC and drive)
- Command options include:
 - \pm 10V torque or velocity command
 - Pulse train or master encoder position command (accepts line driver or open collector) with electronic gearing
 - Powerful built-in motion controller for position control using 99 preset positions (enter these during development, or send them through the communications options above during runtime)
 - Internal sequencing for position/speed



commands, registration (capture/compare), electronic camming, homing (10 different options), Jumps, and arithmetic statements.

- The 3.1 kHz bandwidth allows for high-level automatic tuning. Several modes of tuning are available including Auto Tune that can estimate the load inertia and fine-tune the system when all the loads are attached.
- Optically isolated digital inputs (10) and outputs (6), analog outputs for monitor signals (2), and line driver output for encoder (with scalable resolution).
- Other Features:
 - Secondary/Auxiliary encoder feedback (for true closed loop control)
 - Registration ability
 - Analog positioning
 - Safe Torque Off (STO) included - so no need for large, bulky contactors to disconnect power from the drive in E-stop situations
 - Absolute Encoder operation (with optional encoder battery backup)
 - Electronic camming (you can define the cam with SureServo2 Pro software or you can import an Excel spreadsheet)
 - Advanced Scope feature that can monitor a variety of command and status signals, including output speed, torque, power, etc.

Motor features

- Low inertia models:
 - 100W, 200W, 400W, 750W, 1kW, 1.5 kW, and 2kW
 - Speeds up to 6,000 rpm
- Medium inertia models:
 - 1kW, 1.5 kW, 2kW, and 3kW
 - Speeds up to 3,000 rpm
- High inertia models:
 - 3kW, 4.5 kW, 5.5 kW, 7.5 kW, 11kW, and 15kW
 - Speeds up to 3,000 rpm
- Permanent magnet 3-phase synchronous motor
- Keyed drive shafts support clamp-on style couplings or key-style couplings
- Integrated encoder with 16,777,216 encoder pulses/revolution plus marker pulse (once per revolution)
- Optional 24 VDC spring-set holding brakes (xxxxB series motors)
- Standard hook-up cables for motor power, encoder, and brake (separate brake cable for brake motors 230V systems 5.5kW and larger or 460V systems 11kW and larger)
- Motor cables available in standard or flex-rated lengths of 3, 5, 10, and 20m
- Standard 50-pin DIN-rail mounted break-out kit for the drive's CN1 connector (with screw terminal connections), or 20-pin spring clamp terminal block (limited I/O) that mounts directly to the drive

SureServo2 tuning technology

The SureServo2 drive closes the loop on current, velocity, and position (depending on control mode selection). The 3.1 kHz bandwidth in the drive assures precise speed and current control and easy tuning. Proportional gain, integral gain and compensation, feed forward compensation, command low pass filter, and five (5) notch filters for resonance suppression are available. Auto Tuning has been greatly improved and can easily tune systems with as much as 60:1 inertia mismatch.

There is an inertia estimation function that analyzes the motor and load to measure how much inertia is coupled to the motor.

The drive has several tuning methods available:

- One Touch Auto Tuning—the drive tunes the motor without any motion (static motor/system analysis)
- Normal Auto Tuning—the drive tunes the load while an external controller or the drive's internal indexer provides point-to-point moves
- Assisted Tuning—3 modes where the drive tunes the motor while moving. The user can adjust responsiveness while the drive is analyzing the system
- Manual Tuning—20+ parameters are available to give power users the ultimate flexibility to tune their systems.

SureServo2 Built-in motion controller

While the SureServo2 drives can accept traditional commands from host controls, they can also provide their own internal motion control. For example, up to 99 index moves can be pre-defined and stored in the drive and then selected and executed using digital inputs (inputs as events or inputs used as a multiplexer) or communication (serial Modbus, Modbus TCP, or Ethernet/IP). The index profiles can also be changed while in-process with digital events or via comms. The internal motion can consist of incremental or absolute moves, and can be sequenced internally with delays in between the moves or moves can be linked together so they are processed one after the other.

Multi-axis systems can be controlled via digital inputs, or serial/Ethernet communication. The motion can be commanded from a powerful external controller that sends out high speed pulses to each drive, or the motion can be initiated by a low-level controller (the simplest CLICK PLC) since each drive has a powerful motion controller inside. Applications include press feeds, auger fillers, rotary tables, robots for pick and place, test or assembly operations, drilling, cutting, tapping, and similar applications using simple index moves for single or multi-axis motion.

SureServo2

Optional Holding Brake

Each SureServo2 motor rating can be ordered with an optional 24VDC spring-set holding brake that holds the motor in place when power is removed.

SureGear® Precision Gearboxes for Servo motors

Inertia balancing issue in your design?

The SureGear PGA series easily mates to SureServo2 motors. Everything you need to mount your SureServo2 motor is included!



- Four gear ratios available (5, 10, 15, 25:1)
- Mounting hardware included for attaching to SureServo2 motors
- Industry-standard mounting dimensions
- Thread-in mounting style
- Best-in-class backlash (5 arc-min)
- 5-year warranty

How to select and apply SureServo2 systems

The primary purpose of the AC servo system is to precisely control the motion of the load. The most fundamental considerations in selecting the servo system are “reflected” load inertia, servo system maximum speed requirement, servo system continuous torque requirement, and servo system peak torque requirement. In a retrofit application, select the largest torque SureServo2 system that most closely matches these parameters for the system being replaced. In a new application, these parameters should be determined through calculation and/or measurement. SureServo2 Pro has the ability to measure the load (reflected) inertia and accurately measure the motor torque output.

AutomationDirect has teamed with Copperhill Technologies to provide free servo-sizing software. “VisualSizer-SureServo” software will assist in determining the correct motor and drive for your application by calculating the reflected load inertia and required speed and torque based on the load configuration. “VisualSizer-SureServo” software can be downloaded from www.automationdirect.com on the store page for your drive.

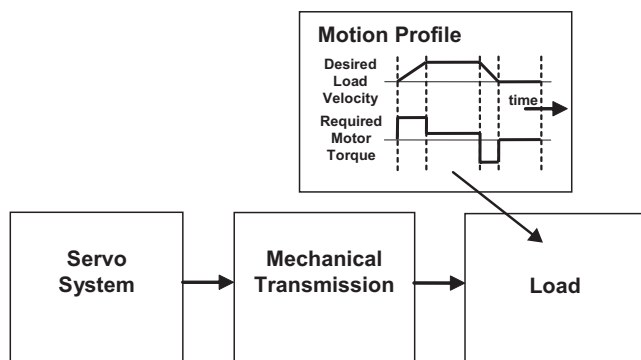

1. “Reflected” load inertia

The inertia of everything attached to the servo motor driveshaft needs to be considered and the total “reflected” inertia needs to be determined. This means that all elements of any mechanical transmission and load inertia need to be translated into an equivalent inertia as if attached directly to the motor driveshaft. The ratio of “reflected” load inertia to motor inertia needs to be carefully considered when selecting the servo system.

In general, applications that need high response or bandwidth will benefit from keeping the ratio of load inertia to motor inertia as low as possible and ideally under 10:1. Systems with ratios as high as 200:1 can be implemented, but corresponding lower bandwidth or responsiveness must be accepted. The servo response including the attached load inertia is determined by the servo tuning. SureServo2 systems may be tuned manually, fully Automatically, or via a hybrid mode where the software tunes the system with input for system responsiveness from the user.

2. Torque and speed

With knowledge of the motion profile and any mechanical transmission between the motor and load, calculations can be made to determine the required servo motor continuous torque, peak torque, and maximum motor speed. The required amount of continuous torque must fall inside the continuous operating region of the system torque-speed curve (you can check the continuous torque at the average speed of the motion profile). The required amount of peak torque must also fall within the servo system’s intermittent operating region of the system torque-speed curve (you need to check this value at the required maximum speed or torque). If you have a SureServo2 system, these values are easily captured and recorded with the Scope feature built into SureServo2 Pro. If you are designing the system, use VisualSizer to define the system and calculate expected inertia and required power.

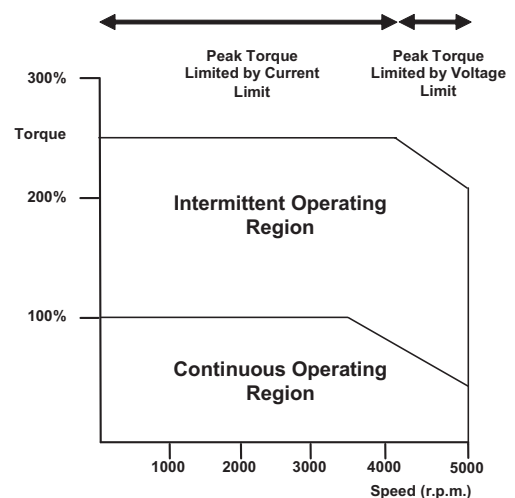



AC Servo Systems

Application tip - coupling considerations

The SureServo2 motors have keyed shafts that can be used with keyed couplings or with clamp-on or compression style couplings. "Servo-grade" clamp-on or compression style couplings are usually the best choice when you consider the stiffness, torque rating, and inertia. Higher stiffness

(lb-in/radian) is needed for better response but there is a trade-off between the stiffness and the added inertia of the coupling. Concerning the torque rating of the coupling, use a safety factor of 1.25 over the SureServo2 **peak** torque requirement of your application.

Available Couplings

Mechanical transmissions

Common mechanical transmissions include leadscrews, rack & pinion mechanisms, conveyors, gears, and timing belts. The use of leadscrew, rack & pinion, or conveyor are common ways to translate the rotary motion of the servo motor into linear motion of the load. The use of a speed reducer such as a gearbox or timing belt can be very beneficial as follows:

1. Reduction of reflected load inertia

As a general rule, it is beneficial to keep the reflected load inertia as low as possible while using the full range of servo speed. SureServo2 systems can go up to 6,000 rpm for the low inertia motors and up to 3,000 rpm for the medium inertia motors.

Example: A gearbox reduces the required torque by a factor of the gear ratio, and reduces the reflected load inertia by a factor of the gear ratio squared. A 10:1 gearbox reduces output speed to 1/10, increases output torque 10 times, and decreases reflected inertia to 1/100.

However, when investigating the effect of different speed reduction ratios DO NOT forget to include the added inertia of couplings, gearbox, or timing belt pulleys. These added inertias can be significant, and can negate any inertia reduction due to the speed reduction.

2. Low speed and high torque applications

If the application requires low speed and high torque then it is common to introduce a speed reducer so that the servo system can operate over more of the available speed range. This could also have the added benefit of reducing the servo motor torque requirement which could allow you to use a smaller and lower cost servo system. Additional benefits are also possible with reduction in reflected inertia, increased number of motor encoder counts at the load, and increased ability to reject load disturbances due to mechanical advantage of the speed reducer.

3. Space limitations and motor orientation

SureServo2 motors can be mounted in any orientation, but the shaft seal should not be immersed in oil (open-frame gearbox, etc.). Reducers can possibly allow the use of a smaller motor or allow the motor to be repositioned. For example, some reducers would allow for in-line, right angle, or parallel mounting of the motor.

For more information, refer to the website listed below.

Mechanical Transmission: [Timing Belts and Pulleys](#) [Precision Gearboxes](#)

Ordering guide instructions

The following four pages are your ordering guide for SureServo2 systems. Each system has a torque-speed curve included for reference. This is the fundamental information that you need to select the servo motor and matching drive for your application.

Each system needs:

- Motor
- Drive
- Motor Power Cable
- Motor Encoder Cable
- I/O connections (either CN1 cable + RTB breakout board, or an LTB20 breakout board that mounts on the drive)
- For brakemotors 4.5 kW and below, the brake wiring is included in the power cable. For brakemotors 5.5 kW and above, a separate brake cable is required.

A wide variety of optional accessories are also available, such as Ethernet cards, RS485 splitters/terminators, toroids, etc.

You can also use the SureServo2 selector tool on the AutomationDirect.com website to help you configure your system.



AC Servo System Configuration

Torque to SureServo2 System Quick Reference

230V System Torque			
System Rated Torque (N-m)	System Maximum Torque (N-m)	Suggested Servo Motor	Required Servo Drive
0.32	1.12	SV2L-201N or SV2L-201B	SV2A-2040
0.64	2.24	SV2L-202N or SV2L-202B	SV2A-2040
1.27	3.96	SV2L-204N or SV2L-204B	SV2A-2040
2.39	7.86	SV2L-207N or SV2L-207B	SV2A-2075
3.18	8.12	SV2L-210N or SV2L-210B	SV2A-2150
4.77	14.32	SV2M-210N or SV2M-210B	SV2A-2150
7.16	14.88	SV2M-215N or SV2M-215B	SV2A-2150
9.55	24.54	SV2M-220N or SV2M-220B	SV2A-2200
17.55	48.29	SV2M-230N or SV2M-230B	SV2A-2300
28.65	71.62	SV2H-245N or SV2H-245B	SV2A-2550
35.01	87.53	SV2H-255N or SV2H-255B	SV2A-2550
47.74	119.36	SV2H-275N or SV2H-275B	SV2A-2750
70	175	SV2H-2B0N or SV2H-2B0B	SV2A-2F00
95.4	224.0	SV2H-2F0N or SV2H-2F0B	SV2A-2F00

460V System Torque			
System Rated Torque (N-m)	System Maximum Torque (N-m)	Suggested Servo Motor	Required Servo Drive
1.27	4.45	SV2L-404N or SV2L-404B	SV2A-4040
2.24	7.58	SV2L-407N or SV2L-407B	SV2A-4075
3.18	9.54	SV2L-410N or SV2L-410B	SV2A-4150
4.77	14.32	SV2M-410N or SV2M-410B	SV2A-4150
7.16	18.1	SV2L-415N or SV2L-415B	SV2A-4150
9.55	28.65	SV2L-420N or SV2L-420B	SV2A-4200
19.1	49.38	SV2H-430N or SV2H-430B	SV2A-4300
28.65	64.61	SV2H-445N or SV2H-445B	SV2A-4550
35.01	73.48	SV2H-455N or SV2H-455B	SV2A-4550
47.74	93.71	SV2H-475N or SV2H-475B	SV2A-4750
70	175	SV2H-4B0N or SV2H-4B0B	SV2A-4F00
95.4	224.0	SV2H-4F0N or SV2H-4F0B	SV2A-4F00



AC Servo System Configuration

SureServo2 AC servo drive, motor, and cable combinations

	Input Voltage	Torque Chart	SureServo2 Motor	SureServo2 Drive	Power Cable*	Encoder Cable*
100W Low Inertia System	120V		SV2L-201N	SV2A-2040	SV2C-PA18-xxNN	SV2C-E122-xxNN
			SV2L-201B		SV2C-PA18-xxFN	SV2C-E122-xxFN
	230V		SV2L-201N		SV2C-PA18-xxNN	SV2C-E122-xxNN
			SV2L-201B		SV2C-PA18-xxFN	SV2C-E122-xxFN
200W Low Inertia System	120V		SV2L-202N	SV2A-2040	SV2C-PA18-xxNN	SV2C-E122-xxNN
			SV2L-202B		SV2C-PA18-xxFN	SV2C-E122-xxFN
	230V		SV2L-202N		SV2C-PA18-xxNN	SV2C-E122-xxNN
			SV2L-202B		SV2C-PA18-xxFN	SV2C-E122-xxFN

Note: "xx" in the cable part numbers represents cable length: SV2C-xxxx-10xx is a 10m cable.
 The final two digits indicate flex rating and motor brake compatibility:
 SV2C-xxxx-xxNN is a non-flex, non-brake motor cable SV2C-xxxx-xxFN is a flex-rated, non-brake cable
 SV2C-xxxx-xxNB is a non-flex, brake motor cable SV2C-xxxx-xxFB is a flex-rated, brake motor cable

All Systems I/O

SV2-CN1-CBL50xxx + SV2-CN1-RTB50

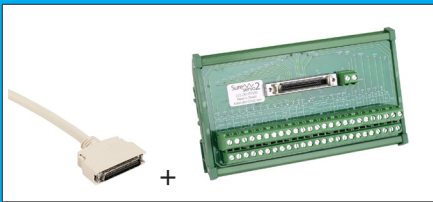

OR

SV2-CN1-LTB20





[SureServo2 System Selector](#)
[Online](#)



AC Servo System Configuration

SureServo2 AC servo drive, motor, and cable combinations, *continued*

Input Voltage	Torque Chart	SureServo2 Motor	SureServo2 Drive	Power Cable*	Encoder Cable*
120V		SV2L-204N	SV2A-2040	SV2C-PA18-xxNN	SV2C-E122-xxNN
				SV2C-PA18-xxFN	SV2C-E122-xxFN
		SV2L-204B		SV2C-PB18-xxNB	SV2C-E122-xxNN
				SV2C-PB18-xxFB	SV2C-E122-xxFN
230V		SV2L-204N	SV2A-2040	SV2C-PA18-xxNN	SV2C-E122-xxNN
				SV2C-PA18-xxFN	SV2C-E122-xxFN
		SV2L-204B		SV2C-PB18-xxNB	SV2C-E122-xxNN
				SV2C-PB18-xxFB	SV2C-E122-xxFN
460V		SV2L-404N	SV2A-4040	SV2C-PA18-xxNN	SV2C-E122-xxNN
				SV2C-PA18-xxFN	SV2C-E122-xxFN
		SV2L-404B		SV2C-PB18-xxNB	SV2C-E122-xxNN
				SV2C-PB18-xxFB	SV2C-E122-xxFN

400W Low Inertia System

Note: "xx" in the cable part numbers represents cable length: SV2C-xxxx-10xx is a 10m cable.
 The final two digits indicate flex rating and motor brake compatibility:
 SV2C-xxxx-xxNN is a non-flex, non-brake motor cable SV2C-xxxx-xxFN is a flex-rated, non-brake cable
 SV2C-xxxx-xxNB is a non-flex, brake motor cable SV2C-xxxx-xxFB is a flex-rated, brake motor cable

All Systems I/O

SV2-CN1-CBL50xxx + SV2-CN1-RTB50

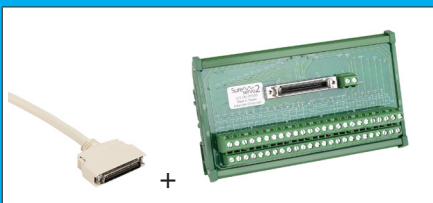

OR

SV2-CN1-LTB20





**SureServo2 System Selector
Online**



AC Servo System Configuration

SureServo2 AC servo drive, motor, and cable combinations, *continued*

750W Low Inertia System	Input Voltage	Torque Chart	SureServo2 Motor	SureServo2 Drive	Power Cable*	Encoder Cable*
	120V		SV2L-207N	SV2A-2075	SV2C-PA18-xxNN	SV2C-E122-xxNN
			SV2L-207B		SV2C-PA18-xxFN	SV2C-E122-xxFN
	230V		SV2L-207N	SV2A-2075	SV2C-PA18-xxNN	SV2C-E122-xxNN
SV2L-207B			SV2C-PA18-xxFN		SV2C-E122-xxFN	
460V		SV2L-407N	SV2A-4075	SV2C-PA18-xxNN	SV2C-E122-xxNN	
		SV2L-407B		SV2C-PA18-xxFN	SV2C-E122-xxFN	
				SV2C-PB18-xxNB	SV2C-E122-xxNN	
				SV2C-PB18-xxFB	SV2C-E122-xxFN	

Note: "xx" in the cable part numbers represents cable length: SV2C-xxxx-10xx is a 10m cable.
 The final two digits indicate flex rating and motor brake compatibility:
 SV2C-xxxx-xxNN is a non-flex, non-brake motor cable SV2C-xxxx-xxFN is a flex-rated, non-brake cable
 SV2C-xxxx-xxNB is a non-flex, brake motor cable SV2C-xxxx-xxFB is a flex-rated, brake motor cable

All Systems I/O

SV2-CN1-CBL50xxx + SV2-CN1-RTB50

OR

SV2-CN1-LTB20



[SureServo2 System Selector Online](#)



AC Servo System Configuration

SureServo2 AC servo drive, motor, and cable combinations, *continued*

Input Voltage	Torque Chart	SureServo2 Motor	SureServo2 Drive	Power Cable*	Encoder Cable*
120V		SV2L-210N	SV2A-2150	SV2C-PC16-xxNN	SV2C-E222-xxNN
				SV2C-PC16-xxFN	SV2C-E222-xxFN
		SV2L-210B		SV2C-PC16-xxNB	SV2C-E222-xxNN
				SV2C-PC16-xxFB	SV2C-E222-xxFN
230V		SV2L-210N	SV2A-2150	SV2C-PC16-xxNN	SV2C-E222-xxNN
				SV2C-PC16-xxFN	SV2C-E222-xxFN
		SV2L-210B		SV2C-PC16-xxNB	SV2C-E222-xxNN
				SV2C-PC16-xxFB	SV2C-E222-xxFN
460V		SV2L-410N	SV2A-4150	SV2C-PC16-xxNN	SV2C-E222-xxNN
				SV2C-PC16-xxFN	SV2C-E222-xxFN
		SV2L-410B		SV2C-PC16-xxNB	SV2C-E222-xxNN
				SV2C-PC16-xxFB	SV2C-E222-xxFN

1.0 kW Low Inertia System

Note: "xx" in the cable part numbers represents cable length: SV2C-xxxx-10xx is a 10m cable.
 The final two digits indicate flex rating and motor brake compatibility:
 SV2C-xxxx-xxNN is a non-flex, non-brake motor cable SV2C-xxxx-xxFN is a flex-rated, non-brake cable
 SV2C-xxxx-xxNB is a non-flex, brake motor cable SV2C-xxxx-xxFB is a flex-rated, brake motor cable

All Systems I/O

SV2-CN1-CBL50xxx + SV2-CN1-RTB50

OR

SV2-CN1-LTB20



SureServo2 System Selector
[Online](#)



AC Servo System Configuration

SureServo2 AC servo drive, motor, and cable combinations, *continued*

Input Voltage	Torque Chart	SureServo2 Motor	SureServo2 Drive	Power Cable*	Encoder Cable*	
120V		SV2M-210N	SV2A-2150	SV2C-PC12-xxNN	SV2C-E222-xxNN	
					SV2C-PC12-xxFN	SV2C-E222-xxFN
		SV2M-210B			SV2C-PC12-xxNB	SV2C-E222-xxNN
					SV2C-PC12-xxFB	SV2C-E222-xxFN
230V		SV2M-210N	SV2A-2150	SV2C-PC12-xxNN	SV2C-E222-xxNN	
					SV2C-PC12-xxFN	SV2C-E222-xxFN
		SV2M-210B			SV2C-PC12-xxNB	SV2C-E222-xxNN
					SV2C-PC12-xxFB	SV2C-E222-xxFN
460V		SV2M-410N	SV2A-4150	SV2C-PC16-xxNN	SV2C-E222-xxNN	
					SV2C-PC16-xxFN	SV2C-E222-xxFN
		SV2M-410B			SV2C-PC16-xxNB	SV2C-E222-xxNN
					SV2C-PC16-xxFB	SV2C-E222-xxFN

Note: "xx" in the cable part numbers represents cable length: SV2C-xxxx-10xx is a 10m cable.
 The final two digits indicate flex rating and motor brake compatibility:
 SV2C-xxxx-xxNN is a non-flex, non-brake motor cable SV2C-xxxx-xxFN is a flex-rated, non-brake cable
 SV2C-xxxx-xxNB is a non-flex, brake motor cable SV2C-xxxx-xxFB is a flex-rated, brake motor cable

All Systems I/O

SV2-CN1-CBL50xxx + SV2-CN1-RTB50

OR

SV2-CN1-LTB20



[SureServo2 System Selector Online](#)



AC Servo System Configuration

SureServo2 AC servo drive, motor, and cable combinations, *continued*

	Input Voltage	Torque Chart	SureServo2 Motor	SureServo2 Drive	Power Cable*	Encoder Cable*	
1.5 kW Medium Inertia System	120V		SV2M-215N	SV2A-2150	SV2C-PC12-xxNN	SV2C-E222-xxNN	
			SV2M-215B		SV2C-PC12-xxFN	SV2C-E222-xxFN	
	230V		SV2M-215N		SV2C-PC12-xxNN	SV2C-E222-xxNN	
			SV2M-215B		SV2C-PC12-xxFN	SV2C-E222-xxFN	
1.5 kW Low Inertia System	460V		SV2L-415N	SV2A-4150	SV2C-PC16-xxNN	SV2C-E222-xxNN	
			SV2L-415B		SV2C-PC16-xxFN	SV2C-E222-xxFN	
						SV2C-PC16-xxNB	SV2C-E222-xxNN
						SV2C-PC16-xxFB	SV2C-E222-xxFN

Note: "xx" in the cable part numbers represents cable length: SV2C-xxxx-10xx is a 10m cable.
 The final two digits indicate flex rating and motor brake compatibility:
 SV2C-xxxx-xxNN is a non-flex, non-brake motor cable SV2C-xxxx-xxFN is a flex-rated, non-brake cable
 SV2C-xxxx-xxNB is a non-flex, brake motor cable SV2C-xxxx-xxFB is a flex-rated, brake motor cable

All Systems I/O

SV2-CN1-CBL50xxx + SV2-CN1-RTB50

OR

SV2-CN1-LTB20



[SureServo2 System Selector Online](#)



AC Servo System Configuration

SureServo2 AC servo drive, motor, and cable combinations, *continued*

	Input Voltage	Torque Chart	SureServo2 Motor	SureServo2 Drive	Power Cable*	Encoder Cable*
2.0 kW Medium Inertia System	120V		SV2M-220N	SV2A-2200	SV2C-PD12-xxNN	SV2C-E222-xxNN
					SV2C-PD12-xxFN	SV2C-E222-xxFN
			SV2M-220B		SV2C-PD12-xxNB	SV2C-E222-xxNN
					SV2C-PD12-xxFB	SV2C-E222-xxFN
2.0 kW Medium Inertia System	230V		SV2M-220N	SV2A-2200	SV2C-PD12-xxNN	SV2C-E222-xxNN
					SV2C-PD12-xxFN	SV2C-E222-xxFN
			SV2M-220B		SV2C-PD12-xxNB	SV2C-E222-xxNN
					SV2C-PD12-xxFB	SV2C-E222-xxFN
2.0 kW Low Inertia System	460V		SV2L-420N	SV2A-4200	SV2C-PC16-xxNN	SV2C-E222-xxNN
					SV2C-PC16-xxFN	SV2C-E222-xxFN
			SV2L-420B		SV2C-PC16-xxNB	SV2C-E222-xxNN
					SV2C-PC16-xxFB	SV2C-E222-xxFN

Note: "xx" in the cable part numbers represents cable length: SV2C-xxxx-10xx is a 10m cable.

The final two digits indicate flex rating and motor brake compatibility:

SV2C-xxxx-xxNN is a non-flex, non-brake motor cable

SV2C-xxxx-xxNB is a non-flex, brake motor cable

SV2C-xxxx-xxFN is a flex-rated, non-brake cable

SV2C-xxxx-xxFB is a flex-rated, brake motor cable

All Systems I/O

SV2-CN1-CBL50xxx + SV2-CN1-RTB50

OR

SV2-CN1-LTB20



SureServo2 System Selector
[Online](#)



AC Servo System Configuration

SureServo2 AC servo drive, motor, and cable combinations, *continued*

Input Voltage	Torque Chart	SureServo2 Motor	SureServo2 Drive	Power Cable*	Encoder Cable*
230V		SV2M-230N	SV2A-2300	SV2C-PD12-xxNN	SV2C-E222-xxNN
				SV2C-PD12-xxFN	SV2C-E222-xxFN
		SV2M-230B		SV2C-PD12-xxNB	SV2C-E222-xxNN
				SV2C-PD12-xxFB	SV2C-E222-xxFN
460V		SV2H-430N	SV2A-4300	SV2C-PD12-xxNN	SV2C-E222-xxNN
				SV2C-PD12-xxFN	SV2C-E222-xxFN
		SV2H-430B		SV2C-PD12-xxNB	SV2C-E222-xxNN
				SV2C-PD12-xxFB	SV2C-E222-xxFN

Note: "xx" in the cable part numbers represents cable length: SV2C-xxxx-10xx is a 10m cable.

The final two digits indicate flex rating and motor brake compatibility:

SV2C-xxxx-xxNN is a non-flex, non-brake motor cable

SV2C-xxxx-xxFN is a flex-rated, non-brake cable

SV2C-xxxx-xxNB is a non-flex, brake motor cable

SV2C-xxxx-xxFB is a flex-rated, brake motor cable

All Systems I/O

SV2-CN1-CBL50xxx + SV2-CN1-RTB50

OR

SV2-CN1-LTB20



SureServo2 System Selector
[Online](#)



AC Servo System Configuration

SureServo2 AC servo drive, motor, and cable combinations, *continued*

Input Voltage	Torque Chart	SureServo2 Motor	SureServo2 Drive	Power Cable*	Encoder Cable*
230V		SV2H-245N	SV2A-2550	SV2C-PD08-xxNN	SV2C-E222-xxNN
				SV2C-PD08-xxFN	SV2C-E222-xxFN
		SV2H-245B		SV2C-PD08-xxNB	SV2C-E222-xxNN
				SV2C-PD08-xxFB	SV2C-E222-xxFN
460V		SV2H-445N	SV2A-4550	SV2C-PD08-xxNN	SV2C-E222-xxNN
				SV2C-PD08-xxFN	SV2C-E222-xxFN
		SV2H-445B		SV2C-PD08-xxNB	SV2C-E222-xxNN
				SV2C-PD08-xxFB	SV2C-E222-xxFN

Note: "xx" in the cable part numbers represents cable length: SV2C-xxxx-10xx is a 10m cable.
 The final two digits indicate flex rating and motor brake compatibility:
 SV2C-xxxx-xxNN is a non-flex, non-brake motor cable SV2C-xxxx-xxFN is a flex-rated, non-brake cable
 SV2C-xxxx-xxNB is a non-flex, brake motor cable SV2C-xxxx-xxFB is a flex-rated, brake motor cable

All Systems I/O

SV2-CN1-CBL50xxx + SV2-CN1-RTB50

OR

SV2-CN1-LTB20



[SureServo2 System Selector Online](#)



AC Servo System Configuration

SureServo2 AC servo drive, motor, and cable combinations, *continued*

Input Voltage	Torque Chart	SureServo2 Motor	SureServo2 Drive	Power Cable*	Encoder Cable*
230V		SV2H-255N	SV2A-2550	SV2C-PF06-xxNN	SV2C-E222-xxNN
				SV2C-PF06-xxFN	SV2C-E222-xxFN
		SV2H-255B		SV2C-PF06-xxNN and SV2C-B120-xxxx	SV2C-E222-xxNN
				SV2C-PF06-xxFN and SV2C-B120-xxxx	SV2C-E222-xxFN
460V		SV2H-455N	SV2A-4550	SV2C-PD08-xxNN	SV2C-E222-xxNN
				SV2C-PD08-xxFN	SV2C-E222-xxFN
		SV2H-455B		SV2C-PD08-xxNN	SV2C-E222-xxNN
				SV2C-PD08-xxFN	SV2C-E222-xxFN

Note: "xx" in the cable part numbers represents cable length: SV2C-xxxx-10xx is a 10m cable.
 The final two digits indicate flex rating and motor brake compatibility:
 SV2C-xxxx-xxNN is a non-flex, non-brake motor cable SV2C-xxxx-xxFN is a flex-rated, non-brake cable
 SV2C-xxxx-xxNB is a non-flex, brake motor cable SV2C-xxxx-xxFB is a flex-rated, brake motor cable

All Systems I/O

SV2-CN1-CBL50xxx + SV2-CN1-RTB50

OR

SV2-CN1-LTB20



[SureServo2 System Selector](#)
[Online](#)



AC Servo System Configuration

SureServo2 AC servo drive, motor, and cable combinations, *continued*

Input Voltage	Torque Chart	SureServo2 Motor	SureServo2 Drive	Power Cable*	Encoder Cable*
230V		SV2H-275N	SV2A-2750	SV2C-PF06-xxNN	SV2C-E222-xxNN
				SV2C-PF06-xxFN	SV2C-E222-xxFN
		SV2H-275B		SV2C-PF06-xxNN and SV2C-B120-xxxx	SV2C-E222-xxNN
				SV2C-PF06-xxFN and SV2C-B120-xxxx	SV2C-E222-xxFN
460V		SV2H-475N	SV2A-4750	SV2C-PD08-xxNN	SV2C-E222-xxNN
				SV2C-PD08-xxFN	SV2C-E222-xxFN
		SV2H-475B		SV2C-PD08-xxNN	SV2C-E222-xxNN
				SV2C-PD08-xxFN	SV2C-E222-xxFN

Note: "xx" in the cable part numbers represents cable length: SV2C-xxxx-10xx is a 10m cable.
 The final two digits indicate flex rating and motor brake compatibility:
 SV2C-xxxx-xxNN is a non-flex, non-brake motor cable SV2C-xxxx-xxFN is a flex-rated, non-brake cable
 SV2C-xxxx-xxNB is a non-flex, brake motor cable SV2C-xxxx-xxFB is a flex-rated, brake motor cable

All Systems I/O

SV2-CN1-CBL50xxx + SV2-CN1-RTB50

OR

SV2-CN1-LTB20



[SureServo2 System Selector Online](#)



AC Servo System Configuration

SureServo2 AC servo drive, motor, and cable combinations, *continued*

Input Voltage	Torque Chart	SureServo2 Motor	SureServo2 Drive	Power Cable*	Encoder Cable*
230V		SV2H-2B0N	SV2A-2F00	SV2C-PF06-xxNN	SV2C-E222-xxNN
				SV2C-PF06-xxFN	SV2C-E222-xxFN
		SV2H-2B0B		SV2C-PF06-xxNN and SV2C-B120-xxNB	SV2C-E222-xxNN
				SV2C-PF06-xxFN and SV2C-B120-xxFB	SV2C-E222-xxFN
460V		SV2H-4B0N	SV2A-4F00	SV2C-PF08-xxNN	SV2C-E222-xxNN
				SV2C-PF08-xxFN	SV2C-E222-xxFN
		SV2H-4B0B		SV2C-PF08-xxNN and SV2C-B120-xxNB	SV2C-E222-xxNN
				SV2C-PF08-xxFN and SV2C-B120-xxFB	SV2C-E222-xxFN

Note: "xx" in the cable part numbers represents cable length: SV2C-xxxx-10xx is a 10m cable.
 The final two digits indicate flex rating and motor brake compatibility:
 SV2C-xxxx-xxNN is a non-flex, non-brake motor cable SV2C-xxxx-xxFN is a flex-rated, non-brake cable
 SV2C-xxxx-xxNB is a non-flex, brake motor cable SV2C-xxxx-xxFB is a flex-rated, brake motor cable

All Systems I/O

SV2-CN1-CBL50xxx + SV2-CN1-RTB50

OR

SV2-CN1-LTB20



[SureServo2 System Selector Online](#)



AC Servo System Configuration

SureServo2 AC servo drive, motor, and cable combinations, *continued*

Input Voltage	Torque Chart	SureServo2 Motor	SureServo2 Drive	Power Cable*	Encoder Cable*
230V		SV2H-2F0N	SV2A-2F00	SV2C-PF04-xxNN	SV2C-E222-xxNN
				SV2C-PF04-xxFN	SV2C-E222-xxFN
		SV2H-2F0B		SV2C-PF04-xxNN and SV2C-B120-xxNB	SV2C-E222-xxNN
				SV2C-PF04-xxFB and SV2C-B120-xxFB	SV2C-E222-xxFN
460V		SV2H-4F0N	SV2A-4F00	SV2C-PF08-xxNN	SV2C-E222-xxNN
				SV2C-PF08-xxFN	SV2C-E222-xxFN
		SV2H-4F0B		SV2C-PF08-xxNN and SV2C-B120-xxNB	SV2C-E222-xxNN
				SV2C-PF08-xxFN and SV2C-B120-xxFB	SV2C-E222-xxFN

Note: "xx" in the cable part numbers represents cable length: SV2C-xxxx-10xx is a 10m cable.
 The final two digits indicate flex rating and motor brake compatibility:
 SV2C-xxxx-xxNN is a non-flex, non-brake motor cable SV2C-xxxx-xxFN is a flex-rated, non-brake cable
 SV2C-xxxx-xxNB is a non-flex, brake motor cable SV2C-xxxx-xxFB is a flex-rated, brake motor cable

All Systems I/O

SV2-CN1-CBL50xxx + SV2-CN1-RTB50

OR

SV2-CN1-LTB20



[SureServo2 System Selector Online](#)



AC Servo System Software



SureServo2 Pro configuration software

SureServo2 Pro is an optional free downloadable configuration software package for the SureServo2 drives. With SureServo2 Pro installed, a PC may be directly connected to the servo drive via a USB programming cable (part# SV2-PGM-USB15 or SV2-PGM-USB30).

Features

- Easy-to-use Parameter Wizards to guide you through the most common setup functions.
- Digital IO/Jog Control allows the user to operate the servo system from the PC. This is a great aid during start-up to allow the servo to perform some basic motion and to check the I/O.
- Parameter Editor - The complete setup for all the drive parameters
- Tune and check the servo response live using the scope feature.
- Upload and download the drive setup. Save the drive setup as a file for backup or future use.
- Edit the drive setup
- View all drive faults
- View drive variable trends in real time
- Create a custom EtherNet/IP EDS file for data transfer to a PLC using pull-down menus
- Motion Programming ability - the PR Window lets you configure the 99 "Paths" that store the motion and sequencing commands in the drive

Parameter editor

The SureServo2 Pro configuration tool logically organizes all servo drive parameters for viewing and editing using the Parameter Editor screen. Each parameter has a factory default that usually allows the servo to run "out-of-the-box".

The parameters can be easily changed with available setting ranges displayed. Tuning modes and parameters can also be changed using SureServo2 Pro. After the parameters have been defined, the complete setup can be stored and archived. Drive configurations can be uploaded, edited, saved, and downloaded as often as necessary.

SS2 Pro software even has an "Offline Mode" so you can configure your drive and program your motion without having to be connected to the drive.

Parameter Editor Example Screen

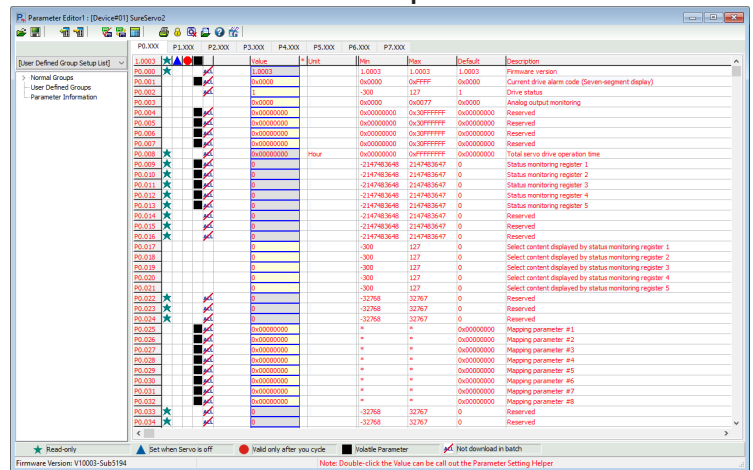

USB Programming Cables

Part Number	Price	Description	Length	Drawing	Compatible Drives
SV2-PGM-USB15	\$32.00	Programming cable, USB A to miniB-USB	1.5 m	PDF	All SureServo2 drives
SV2-PGM-USB30	\$34.50		3m	PDF	



SV2-PGM-USB15



AC Servo System Software

SureServo2 Pro configuration software - (continued)

General Setting Example Screen

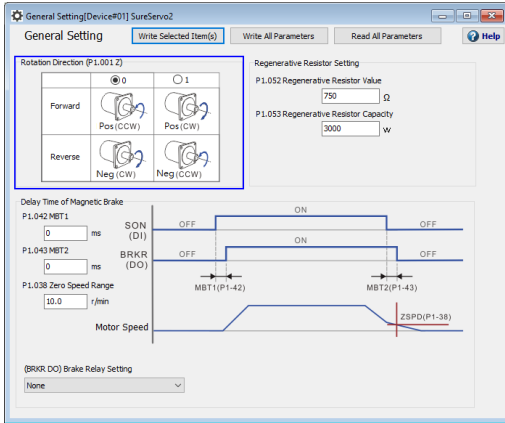

Digital IO/Jog Control screen

The Digital IO/Jog Control screen allows the user to operate the servo system from the PC. This is a great aid during start-up to allow the servo to perform some basic motion and to check the I/O.

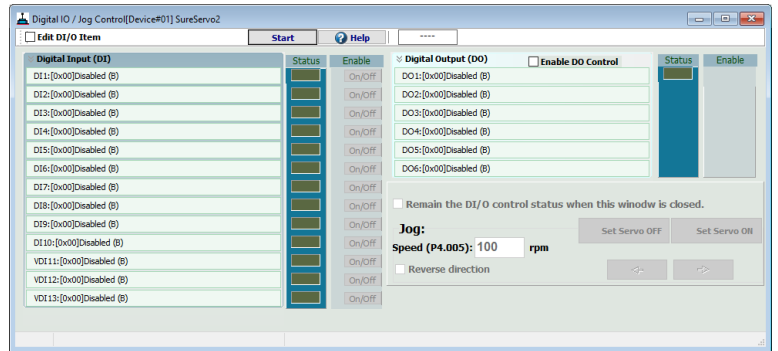

Alarm Information Example Screen

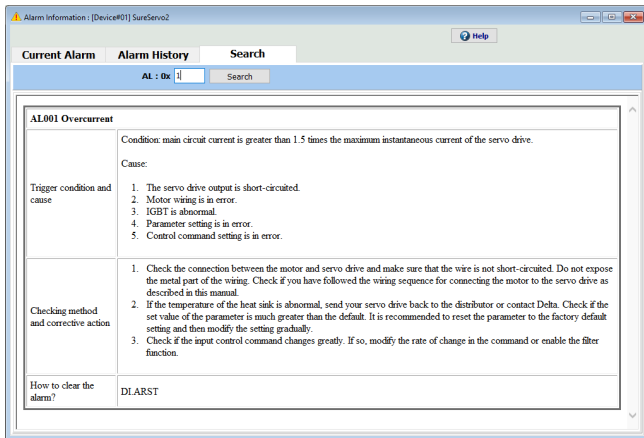

Scope

SureServo2 Pro includes a powerful scope function that allows the user to have as many as eight channels of data displayed simultaneously. Each channel has a drop-down table to select the data to be displayed. The scope has the ability to save traces to a file and load those traces for offline review/analysis. This function is a valuable tool for tuning SureServo2 drives.

PR Mode Setting Example Screen

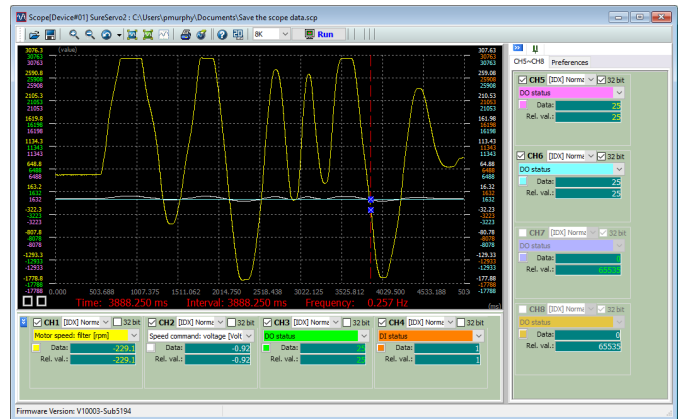
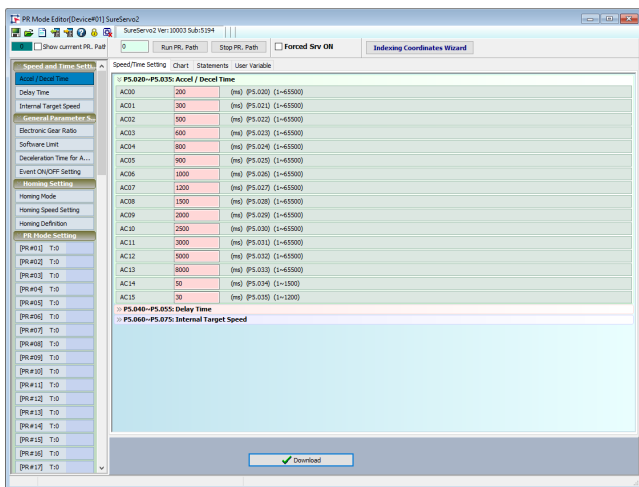

Servo drive overview

Charge

LED is lit when DC bus is energized (may take several seconds for power to dissipate after incoming power is removed)

LED Display

The LED display has 5 full digits and is used to indicate servo status and alarms

Safe Torque Off (STO) Connector Port

Keypad

Five Function keys:

- MODE: Press to change mode
- SHIFT: Press to change parameter group or move cursor left
- UP: Press to increase values
- DOWN: Press to decrease values
- SET: Press to enter value

Control Power Terminal

220VAC drives: control power = 120 or 220 VAC single phase.

460VAC drives: control power = 24VDC

Main Power Terminal

- 1 phase 110VAC: 100W-2kW
- 1 phase 220VAC: 100W-2kW
- 3 phase 220VAC: 100W-15kW
- 3 phase 460VAC: 400W-15kW

Regenerative Resistor Terminal

1. When the internal regenerative resistor is used, the P3 and D terminal are connected together while the P3 and C connection is left open.
2. When an external regenerative resistor is used, it is connected across the P3 and C terminals while the P3 and D connection is left open. See the user manual for recommended resistance and power requirements for each system.

Motor Output Terminal

The servo motor power cable is connected to U, V and W. Use our factory made and tested cables available in 3, 5, 10, or 20 meter lengths for easy and trouble free connection.

Ground Terminals



High Density DB15 Connector

CN5: Auxiliary/Secondary Encoder input. Used for applications requiring Full Closed Loop, Linear Measurement, etc.

USB Connector

Used to connect a PC for configuration with SureServo2 Pro software

Serial Communication Interface

RJ45 connectors for RS485 Modbus communication between drives and controllers. Modbus RTU/ASCII protocol. Use our factory-made cables for easy connection to the PC or the host controller.

I/O Interface

50-pin connector for interfacing the host controller and other types of I/O signals.

- CBL50 + RTB50 = Cable and remote DIN-rail mount module. All I/O pins available.
- LTB20 = Mounted and wired directly at CN1. Most commonly used pins available.
- Command inputs:
 - Pulse and Direction
 - Encoder Follower
 - Analog Velocity/Torque
- (10) Digital Inputs
- (6) Digital Outputs
- (2) Analog Monitors
- Encoder Output (scalable)

A+, A-, B+, B-, Z+, Z-

Encoder Interface

Connector for interfacing the servo motor encoder. Use our factory-made and tested cables available in 3, 5, 10, or 20 meter lengths for easy and trouble free connection.

SureServo2 systems run "out-of-the-box"... but may be reconfigured for many applications!

The SureServo2 drives are fully digital and include over 400 programmable parameters. For convenience, the parameters are grouped into five categories:

1. Monitor parameters
2. Basic parameters
3. Extended parameters
4. Communication parameters
5. Diagnostic and analog parameters
6. Motion control parameters
7. PATH definition parameters

All parameters have commonly used default values which allow you to operate the SureServo2 system "out-of-the-box". However, the programmability and large variety of parameters make the SureServo2 systems suitable for a very broad range of applications, including almost all types of general purpose industrial machinery such as assembly, test, packaging, machine tool, and robotics.

The SureServo2 Pro configuration software has Parameter Wizards to quickly and easily guide you through the most common setup routines.



AC Servo Drive Specifications

230V Servo drive specifications

SureServo2 230V Drive Specifications									
Model	SV2A-2040	SV2A-2075	SV2A-2150	SV2A-2200	SV2A-2300	SV2A-2550	SV2A-2750	SV2A-2F00	
Price	\$383.00	\$477.00	\$509.00	\$598.00	\$660.00	\$836.00	\$977.00	\$1,277.00	
Drawing	PDF	PDF	PDF	PDF	PDF	PDF	PDF	PDF	
Power	Power Rating	400W	750W	1.5 kW	2kW	3kW	5.5 kW	7.5 kW	15kW
	Input Voltage	Single-phase 100–120 VAC, -15% to +10% Single-phase 200–230 VAC, -15% to +10% Three-phase 200–230 VAC, -15% to +10%				Three-phase 200–230 VAC, -15% to +10%			
	Input Current 200–230 VAC 3-phase [Amps] rms	2.76	5.09	8.09	11.36	14.52	27.06	37.33	69.95
	Input Current 100–120 VAC 1-phase [Amps] rms	3.98	7.73	12.56	18.03	–	–	–	–
	Input Current 200–230 VAC 1-phase [Amps] rms	4.69	8.71	14.82	20.83	–	–	–	–
	Continuous Output Current [Amps] rms	2.60	5.10	8.33	13.40	17.92	41.33	49.04	78
	Max. Instantaneous Output Current [Amps] rms	8.56	15.43	20.16	40.57	55.93	91.44	127.46	162.04
	Main Circuit Inrush Current [Amps]	1.44	1.40	1.44	4.64	4.42	9.55	28.68	32.0
	Control Circuit Inrush Current [Amps]	37.0	37.40	39.80	32.40	36.40	32.80	40.0	37.0
Cooling Method	Air Conv. Cooling	Fan Cooling							
Encoder Resolution	24-bit (16777216 p/rev)								
Main Circuit Control	SVPWM control								
Control Mode	Manual / Auto								
Regenerative Resistor	Built-in (external options also available)					External (optional)			
Position Control Mode	Pulse Type	Pulse + Direction, CCW pulse + CW pulse, AB Quadrature							
	Max. Input Pulse Frequency	Pulse + Direction: 4 Mpps; CCW pulse + CW pulse: 4 Mpps; AB Quadrature: single-phase 4 Mpps; Open collector: 200 Kpps							
	Command Source	External pulse / Internal registers							
	Smoothing Method	Low-pass and P-curve filter							
	Torque Limit	Parameter settings							
	Feed Forward Compensation	Parameter settings							



AC Servo Drive Specifications

230V Servo drive specifications (continued)

SureServo2 230V Drive Specifications Continued									
Model		SV2A-2040	SV2A-2075	SV2A-2150	SV2A-2200	SV2A-2300	SV2A-2550	SV2A-2750	SV2A-2F00
Speed Control Mode	Analog Command Input	Voltage Range	±10VDC						
		Resolution	15-bit						
		Input Impedance	1MΩ						
		Time Constant	25μs						
	Speed Control Range1	1 : 6000							
	Command Source	External analog command / Internal registers							
	Smoothing Method	Low-pass and S-curve filter							
	Torque Limit	Parameter settings / Analog input							
	Bandwidth	Maximum 3.1 kHz (closed-loop)							
	Speed Calibration Ratio2	±0.01% at 0% to 100% load fluctuation ±0.01% at ±10% power fluctuation ±0.01% at 0°C to 50°C ambient temperature fluctuation							
Torque Control Mode	Analog Command Input	Voltage Range	±10VDC						
		Input Impedance	1MΩ						
		Time Constant	25μs						
	Command Source	External analog command / Internal registers							
	Smoothing Method	Low-pass filter							
	Speed Limit	Parameter settings / Analog input							
Analog Monitor Output		Monitor signal can be set by parameters (voltage output range: ±8V); resolution:10-bit							
Digital Input/Output	Input	Servo on, Fault reset, Gain switch, Pulse clear, Zero speed clamping, Command input reverse control, Internal position command trigger, Torque limit, Speed limit, Internal position command selection, Motor stop, Speed command selection, Speed / position mode switching, Speed / torque mode switching, Torque / position mode switching, PT / PR command switching, motor override, Forward / reverse limit, Original point, Forward / reverse operation torque limit, Homing activated, E-Cam engage, Forward / reverse JOG input, Event trigger, E-Gear N selection, Pulse input prohibition							
	Output	A, B, Z line driver output Servo ready, Servo on, Zero speed detection, Target speed reached, Target position reached, Torque limiting, Servo alarm, Magnetic brake control, Homing completed, Early warning for overload, Servo warning, Position command overflows, Software limit (reverse direction), Software limit (forward direction), Internal position command completed, Capture procedure completed, Servo procedure completed, Master position area of E-Cam.							

1 - Within the rated load, the speed ratio is: the minimum speed (smooth operation) / rated speed.

2 - Within the rated speed, the speed calibration ratio is: (rotational speed with no load - rotational speed with full load) / rated speed.



AC Servo Drive Specifications

230V Servo drive specifications (continued)

SureServo2 230V Drive Specifications Continued								
Model	<u>SV2A-2040</u>	<u>SV2A-2075</u>	<u>SV2A-2150</u>	<u>SV2A-2200</u>	<u>SV2A-2300</u>	<u>SV2A-2550</u>	<u>SV2A-2750</u>	<u>SV2A-2F00</u>
Protection Function	STO (Category 3 / SIL 2), Overcurrent, Overvoltage, Undervoltage, Overheat, Regeneration error, Overload, Excessive speed deviation, Excessive position deviation, Encoder error, Adjustment error, Emergency stop, Forward / reverse limit error, Excessive deviation of full-closed loop control, Serial communication error, RST leak phase, Serial communication timeout, Short-circuit protection for terminals U, V, W and CN1, CN2, CN3							
Communication Interface	RS-485 / Modbus RTU / USB / Optional EtherNet/IP or Modbus TCP							
Weight [kg (lb)]	0.92 (2.03)	1.3 (2.87)	1.3 (2.87)	2.7 (5.95)	2.7 (5.95)	4.9 (10.8)	7.2 (15.9)	13 (29)
Environment	Installation Site	Indoors (avoid direct sunlight), no corrosive vapor (avoid fumes, flammable gases, and dust)						
	Altitude	Altitude 1000m or lower above sea level						
	Atmospheric Pressure	86kPa - 106kPa						
	Operating Temperature	0°C to 55°C (If operating temperature is above 45°C, forced cooling is required)						
	Storage Temperature	-20°C to 65°C						
	Humidity	Under 0 - 90% RH (non-condensing)						
	Vibration	9.80665 m/s ² (1 G) less than 20 Hz, 5.88 m/s ² (0.6 G) 20 to 50 Hz						
	IP Rating	IP20						
	Power System	TN system3,4						
Approvals	IEC/EN 61800-5-1, UL 508C, TUV (for STO), CE							

3 - TN system: the neutral point of the power system connects directly to the ground. The exposed metal components connect to the ground through the protective ground conductor.

4 - Use a single-phase three-wire power system for the single-phase power model.



AC Servo Drive Specifications

460V Servo drive specifications

SureServo2 460V Drive Specifications									
Model	SV2A-4040	SV2A-4075	SV2A-4150	SV2A-4200	SV2A-4300	SV2A-4550	SV2A-4750	SV2A-4F00	
Price	\$460.00	\$485.00	\$665.00	\$648.00	\$730.00	\$836.00	\$1,050.00	\$1,363.00	
Drawing	PDF	PDF	PDF	PDF	PDF	PDF	PDF	PDF	
Power	Power Rating	400W	750W	1.5 kW	2kW	3kW	5.5 kW	7.5 kW	15kW
	Input Voltage	Three-phase 380–480 VAC, $\pm 10\%$							
	Input Current 380–480 VAC 3-phase [Amps] rms	1.49	2.31	4.98	6.29	9.92	16.83	23.06	36.65
	Continuous Output Current [Amps] rms	1.6	2.91	6.05	6.7	12.6	23.6	28.7	40.5
	Max. Instantaneous Output Current [Amps] rms	5.4	9.7	13.94	21.35	30.46	47.5	57.69	95.3
	Control Power Input Current	1.17	1.17	1.17	1.35	1.63	1.91	1.91	4.26
	Main Circuit Inrush Current [Amps]	5.6	5.6	5.6	12.5	12.5	12.5	12.5	12.5
	Control Circuit Inrush Current [Amps]	5	5	5	4.8	4.8	5.5	5.5	6
Control Circuit Voltage	24VDC								
Cooling Method	Fan cooling								
Encoder Resolution	24-bit (16777216 p/rev)								
Main Circuit Control	SVPWM control								
Control Mode	Manual/Auto								
Regenerative Resistor	Built-in (external options also available)			External (optional)					
Position Control Mode	Pulse Type	Pulse + Direction, CCW pulse + CW pulse, A phase + B phase							
	Max. Input Pulse Frequency	Pulse + Direction: 4 Mpps; CCW pulse + CW pulse: 4 Mpps; A phase + B phase: single-phase 4 Mpps; Open collector: 200 Kpps							
	Command Source	External pulse / Internal registers							
	Smoothing Method	Low-pass, moving-averaging, and S-curve filter							
	E-Gear Ratio	N/M times, limited to $(1/4 < N/M < 262144)$ N: 1–536870911 / M: 1–2147483647							
	Torque Limit	Parameter settings							
	Feed Forward Compensation	Parameter settings							



AC Servo Drive Specifications

460V Servo drive specifications (continued)

SureServo2 460V Drive Specifications Continued										
		Model	SV2A-4040	SV2A-4075	SV2A-4150	SV2A-4200	SV2A-4300	SV2A-4550	SV2A-4750	SV2A-4F00
Speed Control Mode	Analog Command Input	Voltage Range	±10VDC							
		Resolution	12-bit							
		Input Impedance	1MΩ							
		Time Constant	25μs							
	Speed Control Range ¹		1 : 6000							
	Command Source		External analog command / Internal registers							
	Smoothing Method		Low-pass and S-curve filter							
	Torque Limit		Parameter settings / Analog input							
	Bandwidth		Maximum 3.1 kHz (closed-loop)							
	Speed Calibration Ratio ²		±0.01% at 0% to 100% load fluctuation ±0.01% at ±10% power fluctuation ±0.01% at 0°C to 50°C ambient temperature fluctuation							
Torque Control Mode	Analog Command Input	Voltage Range	±10VDC							
		Input Impedance	1MΩ							
		Time Constant	25μs							
	Command Source		External analog command / Internal registers							
	Speed Limit		Parameter settings / Analog input							
Analog Monitor Output		Monitor signal can be set by parameters (voltage output range: ±8V); resolution:10-bit								
Digital Input/Output	Input		Servo on, Fault reset, Gain switch, Pulse clear, Zero speed clamping, Command input reverse control, Internal position command trigger, Torque limit, Speed limit, Internal position command selection, Motor stop, Speed command selection, Speed / position mode switching, Speed / torque mode switching, Torque / position mode switching, PT / PR command switching, Emergency Stop, Forward / reverse limit, Original point, Forward / reverse operation torque limit, Homing activated, E-Cam engage, Forward / reverse JOG input, Event trigger, E-Gear N selection, Pulse input prohibition							
	Output		A, B, Z line driver output Servo ready, Servo on, Zero speed detection, Target speed reached, Target position reached, Torque limiting, Servo alarm, Magnetic brake control, Homing completed, Early warning for overload, Servo warning, Position command overflows, Software limit (reverse direction), Software limit (forward direction), Internal position command completed, Capture procedure completed, Servo procedure completed, Master position area of E-Cam.							

1 - Within the rated load, the speed ratio is: the minimum speed (smooth operation) / rated speed.

2 - Within the rated speed, the speed calibration ratio is: (rotational speed with no load - rotational speed with full load) / rated speed.



AC Servo Drive Specifications

460V Servo drive specifications (continued)

SureServo2 460V Drive Specifications Continued								
Model	SV2A-4040	SV2A-4075	SV2A-4150	SV2A-4200	SV2A-4300	SV2A-4550	SV2A-4750	SV2A-4F00
Protection Function	Overcurrent, Overvoltage, Undervoltage, Overheat, Regeneration error, Overload, Excessive speed deviation, Excessive position deviation, Encoder error, Adjustment error, Emergency stop, Forward / reverse limit error, Excessive deviation of full-closed loop control, Serial communication error, RST leak phase, Serial communication timeout, Short-circuit protection for terminals U, V, W and CN1, CN2, CN3							
Communication Interface	RS-485 / USB							
Weight [kg (lb)]	5.96 [13.1]	5.96 [13.1]	5.96 [13.1]	9.71 [21.4]	9.71 [21.4]	12.14 [26.8]	12.14 [26.8]	15.01 [33.1]
Environment	Installation Site	Indoors (avoid direct sunlight), no corrosive vapor (avoid fumes, flammable gases, and dust)						
	Altitude	1000m or lower above sea level						
	Atmospheric Pressure	86kPa – 106kPa						
	Operating Temperature	0°C to 55°C [32°F to 131°F] (If operating temperature is above 45°C, forced cooling is required)						
	Storage Temperature	-20°C to 65°C [-4°F to 149°F]						
	Humidity	Under 90% RH (non-condensing)						
	Vibration	9.80665 m/s ² (1 G) less than 20 Hz, 5.88 m/s ² (0.6 G) 20 to 50 Hz						
	IP Rating	IP20						
Power System	TN system ^{3,4}							
Approvals	IEC/EN 61800-5-1, UL 508C, TUV (for STO), CE							

3 - TN system: the neutral point of the power system connects directly to the ground. The exposed metal components connect to the ground through the protective ground conductor.

4 - Use a single-phase three-wire power system for the single-phase power model.

AC Servo Motor Specifications

Servo motor overview

24-bit Encoder Connector
1-foot cable with 9-position connector
(Motor-mounted connector is IP67, end-of-cable connector is not liquid tight)

IP67 Housing

Low Inertia Motors

- 100W 40 mm flange
- 200W 60 mm flange
- 400W 60 mm flange
- 750W 80 mm flange

750W and below

Motor Power and Brake Connector
1-foot cable with 6-position connector
(Motor-mounted connector is IP67, end-of-cable connector is not liquid tight)

Keyed Shafts

- 100W 8 mm diameter
- 200W 14 mm diameter
- 400W 14 mm diameter
- 750W 19 mm diameter

With Shaft Seal (liquid tight)

All SureServo2 motors have keyed shafts for use with servo-grade clamp or compression couplings (recommended) or servo-grade keyed couplings.

Motor Power and Brake Connector
(Liquid tight when using AutomationDirect cables)

24-bit Encoder Connector
(Liquid tight when using AutomationDirect cables)

IP67 Housing (IP65 connectors)

1 kW and above

Low, Medium, and High Inertia Motors

- Low Inertia Model:
 - 1kW 100mm flange
 - 1.5 kW 130mm flange
 - 2kW 130mm flange
- Medium Inertia Models:
 - 1kW 130mm flange
 - 1.5kW 130mm flange
 - 2kW 180mm flange
 - 3kW 180mm flange
- High Inertia Models:
 - 3.0kW 180mm flange
 - 4.5kW 180mm flange
 - 5.5kW 180mm flange
 - 7.5kW 180mm flange
 - 11kW 220mm flange
 - 15kW 220mm flange

Keyed Shafts

- Low Inertia Model:
 - 1kW 22mm diameter
 - 1.5 kW 22mm diameter
 - 2kW 22mm diameter
- Medium Inertia Models:
 - 1kW 22mm diameter
 - 1.5kW 22mm diameter
 - 2kW 35mm diameter
 - 3kW 35mm diameter
- High Inertia Models:
 - 3.0kW 35mm diameter
 - 4.5kW 35mm diameter
 - 5.5kW 42mm diameter
 - 7.5kW 42mm diameter
 - 11kW 42mm diameter
 - 15kW 55mm diameter

With Shaft Seal (liquid tight)



AC Servo Motor Specifications

230V Low Inertia Motor Specifications

230V SureServo2 Low Inertia Motor Specifications										
Model	SV2L-201N	SV2L-201B	SV2L-202N	SV2L-202B	SV2L-204N	SV2L-204B	SV2L-207N	SV2L-207B	SV2L-210N	SV2L-210B
Price	\$286.00	\$419.00	\$315.00	\$465.00	\$340.00	\$479.00	\$364.00	\$510.00	\$477.00	\$702.00
Drawing	PDF	PDF	PDF	PDF	PDF	PDF	PDF	PDF	PDF	PDF
Rated Power [kW]	0.1	0.1	0.2	0.2	0.4	0.4	0.75	0.75	1.0	1.0
Rated Torque [N-m]Note 1	0.32	0.32	0.64	0.64	1.27	1.27	2.39	2.39	3.18	3.18
Max. Torque [N-m]	1.12	1.12	2.24	2.24	3.96	3.96	7.86	7.86	8.12	8.12
Rated Speed [rpm]	3000									
Max. Speed [rpm]	6000								5000	
Rated current [Amps] rms	0.9	0.9	1.45	1.45	2.60	2.60	4.5	4.5	8.04	8.04
Max. Instantaneous Current [Amps] rms	3.3	3.3	5.4	5.4	8.56	8.56	15.41	15.41	20.16	20.16
Change of Rated Power [W/s]	16.3	14.90	16.4	14.60	35.8	33.60	37.8	34.40	38.2	30.40
Rotor Inertia [x10 ⁻⁴ kg m ²]	0.0627	0.0689	0.25	0.28	0.45	0.48	1.51	1.66	2.65	3.33
Mechanical Time Constant [ms]	1.13	1.24	1.38	1.54	0.94	1.01	0.91	1.00	0.83	1.05
Torque Constant-KT [N-m/A]	0.356	0.356	0.441	0.441	0.488	0.488	0.531	0.531	0.396	0.396
Voltage Constant-KE [mV/rpm]	13.66	13.66	16.4	16.4	17.2	17.2	18.7	18.7	16.8	16.8
Armature Resistance [Ohm]	8.34	8.34	3.8	3.8	1.68	1.68	0.57	0.57	0.20	0.20
Armature Inductance [mH]	9.85	9.85	8.15	8.15	4.03	4.03	2.2	2.2	1.81	1.81
Electrical Time Constant [ms]	1.18	1.18	2.14	2.14	2.40	2.40	3.86	3.86	9.05	9.05
Insulation Class	Class A (UL), Class B (CE)									
Insulation Resistance	> 100MΩ, 500VDC									
Insulation Strength	1.8 kVAC, 1 second									
Weight [kg]	0.5	0.8	1.1	1.6	1.4	1.9	2.8	3.6	4.3	4.7
Max. Radial Loading [N]	78	78	245	245	245	245	392	392	490	490
Max. Axial Loading [N]	54	54	74	74	74	74	147	147	98	98
Brake Holding Torque [N-m (min)]Note 2	n/a	0.32	n/a	1.3	n/a	1.3	n/a	2.5	n/a	8
Brake Power Consumption (at 20°C) [W]	n/a	6.1	n/a	7.2	n/a	7.2	n/a	8	n/a	18.7
Brake Release Time [ms (max)]	n/a	20	n/a	20	n/a	20	n/a	20	n/a	10
Brake Pull-in Time [ms (max)]	n/a	35	n/a	50	n/a	50	n/a	60	n/a	70
Vibration Grade [μm]	V15									
Operating Temperature [°C]	0–40 °C (32–104 °F)									
Storage Temperature [°C]	-10°C to 80°C (-14°F to 176°F)									
Operating Humidity	20–90% relative humidity (non-condensing)									
Storage Humidity	20–90% relative humidity (non-condensing)									
Vibration Capacity	2.5 G									
IP Rating ³	IP67 (when using waterproof connectors)								IP65 (when using waterproof connectors)	
Encoder Resolution	24-bit (16777216 p/rev)									
Agency Approvals	cUR _{US} , CE									

Note 1—The rated torque is the continuous permissible torque between the 0°C and 40°C operating temperature which is suitable for a servo motor mounted with the following heat sink dimensions: 250mm x 250mm x 6mm made from aluminum (or mounted to equipment with an equivalent heat sinking capability).

Note 2—The built-in servo motor brake is only for holding the load in a stopped state. Do not use for deceleration or as a dynamic brake.

Note 3—All SureServo2 motors are shipped with oil seals installed for IP rating requirements.



AC Servo Motor Specifications

230V Medium Inertia Motor Specifications

230V SureServo2 Medium Inertia Motor Specifications								
Model	SV2M-210N	SV2M-210B	SV2M-215N	SV2M-215B	SV2M-220N	SV2M-220B	SV2M-230N	SV2M-230B
Price	\$497.00	\$711.00	\$537.00	\$795.00	\$651.00	\$863.00	\$735.00	\$947.00
Drawing	PDF	PDF	PDF	PDF	PDF	PDF	PDF	PDF
Rated Power [kW]	1.0	1.0	1.5	1.5	2.0	2.0	3.0	3.0
Rated Torque [N·m]Note 1	4.77	4.77	7.16	7.16	9.55	9.55	17.55	17.55
Max. Torque [N·m]	14.32	14.32	14.88	14.88	24.54	24.54	48.29	48.29
Rated Speed [rpm]	2000						1700	
Max. Speed [rpm]	3000							
Rated current [Amps] rms	5.66	5.66	8.33	8.33	12.1	12.1	17.9	17.9
Max. Instantaneous Current [Amps] rms	19.73	19.73	20.16	20.16	33.66	33.66	55.93	55.93
Change of Rated Power [W/s]	27.1	24.90	45.8	43.10	26.3	24.10	56.0	53.90
Rotor Inertia [x10 ⁻⁴ kg m ²]	8.41	9.14	11.2	11.9	34.7	37.8	55	57.1
Mechanical Time Constant [ms]	1.54	1.67	1.12	1.18	1.75	1.90	1.29	1.34
Torque Constant-KT [N·m/A]	0.843	0.843	0.860	0.860	0.789	0.789	0.980	0.980
Voltage Constant-KE [mV/rpm]	31.9	31.9	31.8	31.8	31.4	31.4	35	35
Armature Resistance [Ohm]	0.47	0.47	0.26	0.26	0.119	0.119	0.077	0.077
Armature Inductance [mH]	5.99	5.99	4.01	4.01	2.84	2.84	1.27	1.27
Electrical Time Constant [ms]	12.74	12.74	15.42	15.42	23.87	23.87	16.49	16.49
Insulation Class	Class A (UL), Class B (CE)							
Insulation Resistance	> 100MΩ, 500VDC							
Insulation Strength	1.8 kVAC, 1 second							
Weight [kg]	7.0	8.4	7.5	8.9	13.5	17.5	18.5	22.5
Max. Radial Loading [N]	490				1176		1470	
Max. Axial Loading [N]	98				490			
Brake Holding Torque [N·m (min)]Note 2	n/a	10	n/a	10	n/a	25	n/a	25
Brake Power Consumption (at 20°C) [W]		19		19		20.4		20.4
Brake Release Time [ms (max)]		10		10		10		10
Brake Pull-in Time [ms (max)]		70		70		70		70
Vibration Grade [μm]	V15							
Operating Temperature [°C]	0–40 °C (32–104 °F)							
Storage Temperature [°C]	-10°C to 80°C (-14°F to 176°F)							
Operating Humidity	20–90% relative humidity (non-condensing)							
Storage Humidity	20–90% relative humidity (non-condensing)							
Vibration Capacity	2.5 G							
IP Rating ³	IP65 (when using waterproof connectors)							
Encoder Resolution	24-bit (16777216 p/rev)							
Agency Approvals	cUR _{US} , CE							

Note 1—The rated torque is the continuous permissible torque between the 0°C and 40°C operating temperature which is suitable for a servo motor mounted with the following heat sink dimensions: 250mm x 250mm x 6mm made from aluminum (or mounted to equipment with an equivalent heat sinking capability).

Note 2—The built-in servo motor brake is only for holding the load in a stopped state. Do not use for deceleration or as a dynamic brake.

Note 3—All SureServo2 motors are shipped with oil seals installed for IP rating requirements.



AC Servo Motor Specifications

230V High Inertia Motor Specifications

230V SureServo2 High Inertia Motor Specifications										
Model	SV2H-245N	SV2H-245B	SV2H-255N	SV2H-255B	SV2H-275N	SV2H-275B	SV2H-2B0N	SV2H-2B0B	SV2H-2F0N	SV2H-2F0B
Price	\$911.00	\$1,415.00	\$1,050.00	\$1,568.00	\$1,273.00	\$1,989.00	\$1,956.00	\$2,682.00	\$2,257.00	\$3,091.00
Drawing	PDF	PDF	PDF	PDF	PDF	PDF	PDF	PDF	PDF	PDF
Rated Power [kW]	4.5	4.5	5.5	5.5	7.5	7.5	11	11	15	15
Rated Torque [N·m]Note 1	28.65	28.65	35.01	35.01	47.74	47.74	70	70	95.4	95.4
Max. Torque [N·m]	71.62	71.62	87.53	87.53	119.36	119.36	175	175	224.0	224.0
Rated Speed [rpm]	1500									
Max. Speed [rpm]	3000					2000				
Rated current [Amps] rms	32.5	32.5	40.12	40.12	47.5	47.5	51.1	51.1	67	67
Max. Instantaneous Current [Amps] rms	91.4	91.4	108.0	108.0	127.46	127.46	129.5	129.5	162	162
Change of Rated Power [W/s]	105.6	101.8	122.8	119.3	159.7	156.6	145.0	141.4	201.8	197.1
Rotor Inertia [x10 ⁻⁴ kg m ²]	77.75	80.65	99.78	102.70	142.7	145.55	338	346.5	451	461.8
Mechanical Time Constant [ms]	0.93	0.96	0.97	0.99	0.84	0.85	1.38	1.41	1.22	1.25
Torque Constant-KT [N·m/A]	0.878	0.878	0.873	0.873	1.005	1.005	1.370	1.370	1.424	1.424
Voltage Constant-KE [mV/rpm]	32.0	32.0	31.0	31.0	35.5	35.5	49	49	50	50
Armature Resistance [Ohm]	0.032	0.032	0.025	0.025	0.02	0.02	0.0261	0.0261	0.0184	0.0184
Armature Inductance [mH]	0.89	0.89	0.71	0.71	0.6	0.6	0.65	0.65	0.48	0.48
Electrical Time Constant [ms]	27.81	27.81	28.4	28.4	30.0	30.0	24.9	24.9	26.09	26.09
Insulation Class	Class A (UL), Class B (CE)						Class F (UL), Class F (CE)			
Insulation Resistance	> 100MΩ, 500VDC									
Insulation Strength	1.8 kVAC, 1 second									
Weight [kg]	23.5	29	30.5	36	40.5	46	56.4	68.4	75	87
Max. Radial Loading [N]	1470			1764			3300			
Max. Axial Loading [N]	490			588			1100			
Brake Holding Torque [N·m (min)]Note 2		55.0		55.0		55.0		115		115
Brake Power Consumption (at 20°C) [W]		19.9		19.9		19.9		28.8		28.8
Brake Release Time [ms (max)]	n/a	10	n/a	10	n/a	10	n/a	10	n/a	10
Brake Pull-in Time [ms (max)]		70		70		70		70		70
Vibration Grade [μm]	V15									
Operating Temperature [°C]	0–40 °C (32–104 °F)									
Storage Temperature [°C]	-10°C to 80°C (-14°F to 176°F)									
Operating Humidity	20–90% relative humidity (non-condensing)									
Storage Humidity	20–90% relative humidity (non-condensing)									
Vibration Capacity	2.5 G									
IP Rating ³	IP65 (when using specified cables)									
Encoder Resolution	24-bit (16777216 p/rev)									
Agency Approvals	cURUS, CE									

Note 1—The rated torque is the continuous permissible torque between the 0°C and 40°C operating temperature which is suitable for a servo motor mounted with the following heat sink dimensions:

300mm x 300mm x 12mm, 400mm x 400mm x 20mm, 550mm x 550mm x 30mm

All made from aluminum (or mounted to equipment with an equivalent heat sinking capability)

Note 2—The built-in servo motor brake is only for holding the load in a stopped state. Do not use it for deceleration or as a dynamic brake.

Note 3—All SureServo2 motors are shipped with oil seals installed for IP rating requirements.



AC Servo Motor Specifications

460V Low Inertia Motor Specifications

460V SureServo2 Low Inertia Motor Specifications										
Model	SV2L-404N	SV2L-404B	SV2L-407N	SV2L-407B	SV2L-410N	SV2L-410B	SV2L-415N	SV2L-415B	SV2L-420N	SV2L-420B
Price	\$360.00	\$515.00	\$388.00	\$555.00	\$505.00	\$745.00	\$580.00	\$855.00	\$687.00	\$899.00
Drawing	PDF	PDF	PDF	PDF	PDF	PDF	PDF	PDF	PDF	PDF
Rated Power [kW]	0.4	0.4	0.75	0.75	1.0	1.0	1.5	1.5	2.0	2.0
Rated Torque [N·m]Note 1	1.27	1.27	2.24	2.24	3.18	3.18	7.16	7.16	9.55	9.55
Max. Torque [N·m]	4.45	4.45	7.58	7.58	9.54	9.54	18.1	18.1	28.65	28.65
Rated Speed [rpm]	3000		3200		3000		2000			
Max. Speed [rpm]	6000		6000		5000		3000			
Rated current [Amps] rms	1.43	1.43	2.90	2.90	4.36	4.36	5.1	5.1	6.7	6.7
Max. Instantaneous Current [Amps] rms	5.25	5.25	9.70	9.70	13.74	13.74	13.28	13.28	21.35	21.35
Change of Rated Power [W/s]	35.8	33.6	33.2	30.2	38.2	30.40	45.9	43.10	62.5	57.4
Rotor Inertia [x10 ⁻⁴ kg m ²]	0.45	0.48	1.51	1.66	2.65	3.33	11.18	11.9	14.59	15.88
Mechanical Time Constant [ms]	1.05	1.12	1.02	1.12	0.81	1.02	1.26	1.34	1.11	1.21
Torque Constant-KT [N·m/A]	0.888	0.888	0.772	0.772	0.729	0.729	1.404	1.404	1.425	1.425
Voltage Constant-KE [mV/rpm]	31.83	31.83	27.83	27.83	29.00	29.00	55.00	55.00	55.00	55.00
Armature Resistance [Ohm]	6.28	6.28	1.38	1.38	0.617	0.617	0.83	0.83	0.57	0.57
Armature Inductance [mH]	13.34	13.34	4.78	4.78	6.03	6.03	11.67	11.67	8.29	8.29
Electrical Time Constant [ms]	2.12	2.12	3.46	3.46	9.77	9.77	14.06	14.06	14.54	14.54
Insulation Class	Class A (UL), Class B (CE)									
Insulation Resistance	> 100 MΩ, 500VDC									
Insulation Strength	2.3 kVAC, 1 sec									
Weight [kg]	1.4	1.9	2.8	3.6	4.3	4.7	7.5	8.9	7.8	9.2
Max. Radial Loading [N]	245	245	392	392	490	490	490	490	490	490
Max. Axial Loading [N]	74	74	147	147	98	98	98	98	98	98
Brake Holding Torque [N·m (min)]Note 2	n/a	1.3	n/a	2.5	n/a	8	n/a	10	n/a	10
Brake Power Consumption (at 20°C) [W]		7.2		8		18.7		19		19
Brake Release Time [ms (max)]		20		20		10		10		10
Brake Pull-in Time [ms (max)]		50		60		70		70		70
Vibration Grade [μm]	V15									
Operating Temperature [°C]	0–40 °C (32–104 °F)									
Storage Temperature [°C]	-10°C to 80°C (-14°F to 176°F)									
Operating Humidity	20–90% relative humidity (non-condensing)									
Storage Humidity	20–90% relative humidity (non-condensing)									
Vibration Capacity	2.5 G									
IP Rating	IP67 (when using waterproof connectors and when an oil seal is fitted to the rotating shaft (for an oil seal model))				IP65 (when using waterproof connectors and when an oil seal is fitted to the rotating shaft (for an oil seal model))					
Encoder Resolution	24-bit (16777216 p/rev)									
Agency Approvals	cURUS, CE									

Note 1—The rated torque is the continuous permissible torque between the 0°C and 40°C operating temperature which is suitable for a servo motor mounted with the following heat sink dimensions: 250mm x 250mm x 6mm made from aluminum (or mounted to equipment with an equivalent heat sinking capability).

Note 2—The built-in servo motor brake is only for holding the load in a stopped state. Do not use for deceleration or as a dynamic brake.



AC Servo Motor Specifications

460V Medium Inertia Motor Specifications

460V SureServo2 Medium Inertia Motor Specifications		
Model	SV2M-410N	SV2M-410B
Price	\$530.00	\$765.00
Drawing	PDF	PDF
Rated Power [kW]	1.0	1.0
Rated Torque [N·m]Note 1	4.77	4.77
Max. Torque [N·m]	14.32	14.32
Rated Speed [rpm]	2000	
Max. Speed [rpm]	3000	
Rated current [Amps] rms	3.6	3.6
Max. Instantaneous Current [Amps] rms	11.41	11.41
Change of Rated Power [W/s]	27.1	24.90
Rotor Inertia [x10 ⁻⁴ kg m ²]	8.41	9.14
Mechanical Time Constant [ms]	1.85	2.01
Torque Constant-KT [N·m/A]	1.325	1.325
Voltage Constant-KE [mV/rpm]	53.20	53.20
Armature Resistance [Ohm]	1.477	1.477
Armature Inductance [mH]	17.79	17.79
Electrical Time Constant [ms]	12.04	12.04
Insulation Class	Class A (UL), Class B (CE)	
Insulation Resistance	> 100 MΩ, 500VDC	
Insulation Strength	2.3 kVAC, 1 sec	
Weight [kg]	7.0	8.4
Max. Radial Loading [N]	490	
Max. Axial Loading [N]	98	
Brake Holding Torque [N·m (min)]Note 2		10
Brake Power Consumption (at 20°C) [W]	n/a	19
Brake Release Time [ms (max)]		10
Brake Pull-in Time [ms (max)]		70
Vibration Grade [μm]	V15	
Operating Temperature [°C]	0–40 °C (32–104 °F)	
Storage Temperature [°C]	-10°C to 80°C (-14°F to 176°F)	
Operating Humidity	20–90% relative humidity (non-condensing)	
Storage Humidity	20–90% relative humidity (non-condensing)	
Vibration Capacity	2.5 G	
IP Rating	IP65 (when using waterproof connectors and when an oil seal is fitted to the rotating shaft (for an oil seal model))	
Encoder Resolution	24-bit (16777216 p/rev)	
Agency Approvals	cUR _{US} , CE	

Note 1—The rated torque is the continuous permissible torque between the 0°C and 40°C operating temperature which is suitable for a servo motor mounted with the following heat sink dimensions: 250mm x 250mm x 6mm made from aluminum (or mounted to equipment with an equivalent heat sinking capability).

Note 2—The built-in servo motor brake is only for holding the load in a stopped state. Do not use for deceleration or as a dynamic brake.



AC Servo Motor Specifications

460V High Inertia Motor Specifications

460V SureServo2 High Inertia Motor Specifications						
Model	SV2H-430N	SV2H-430B	SV2H-445N	SV2H-445B	SV2H-455N	SV2H-455B
Price	\$823.00	\$1,001.00	\$939.00	\$1,456.00	\$1,082.00	\$1,614.00
Drawing	PDF	PDF	PDF	PDF	PDF	PDF
Rated Power [kW]	3.0	3.0	4.5	4.5	5.5	5.5
Rated Torque [N·m]Note 1	19.1	19.1	28.65	28.65	35	35
Max. Torque [N·m]	49.38	49.38	64.61	64.61	73.48	73.48
Rated Speed [rpm]	1500					
Max. Speed [rpm]	3000					
Rated current [Amps] rms	12.2	12.2	21.9	21.9	23.6	23.6
Max. Instantaneous Current [Amps] rms	30.46	30.46	47.5	47.5	47.5	47.5
Change of Rated Power [W/s]	66.4	63.9	105.6	101.8	122.8	119.3
Rotor Inertia [x10 ⁻⁴ kg m ²]	54.95	57.1	77.75	80.65	99.78	80.65
Mechanical Time Constant [ms]	1.20	1.24	1.06	1.10	0.84	0.86
Torque Constant-KT [N·m/A]	1.566	1.566	1.308	1.308	1.483	1.483
Voltage Constant-KE [mV/rpm]	64.4	64.4	53.00	53.00	58.9	58.9
Armature Resistance [Ohm]	0.21	0.21	0.09	0.09	0.07	0.07
Armature Inductance [mH]	4.94	4.94	2.36	2.36	2.20	2.20
Electrical Time Constant [ms]	23.52	23.52	26.22	26.22	31.43	31.43
Insulation Class	Class A (UL), Class B (CE)					
Insulation Resistance	> 100 MΩ, 500VDC					
Insulation Strength	2.3 kVAC, 1 sec					
Weight [kg]	18.5	22.5	23.5	29	30.5	36
Max. Radial Loading [N]	1470				1764	
Max. Axial Loading [N]	490				588	
Brake Holding Torque [N·m (min)]Note 2	25		55		55	
Brake Power Consumption (at 20°C) [W]	20.4		19.9		19.9	
Brake Release Time [ms (max)]	10		10		10	
Brake Pull-in Time [ms (max)]	70		70		70	
Vibration Grade [μm]	V15					
Operating Temperature [°C]	0–40 °C (32–104 °F)					
Storage Temperature [°C]	-10°C to 80°C (-14°F to 176°F)					
Operating Humidity	20–90% relative humidity (non-condensing)					
Storage Humidity	20–90% relative humidity (non-condensing)					
Vibration Capacity	2.5 G					
IP Rating	IP65 (when using waterproof connectors and when an oil seal is fitted to the rotating shaft (for an oil seal model))					
Encoder Resolution	24-bit (16777216 p/rev)					
Agency Approvals	cUR _{US} , CE					

Continued on next page

Note 1–The rated torque is the continuous permissible torque between the 0°C and 40°C operating temperature which is suitable for a servo motor mounted with the following heat sink dimensions:

300mm x 300mm x 12mm

400mm x 400mm x 20mm

550mm x 550mm x 30mm

All made from aluminum (or mounted to equipment with an equivalent heat sinking capability)

Note 2–The built-in servo motor brake is only for holding the load in a stopped state. Do not use it for deceleration or as a dynamic brake.



AC Servo Motor Specifications

460V High Inertia Motor Specifications, *continued*

460V SureServo2 High Inertia Motor Specifications						
Model	SV2H-475N	SV2H-475B	SV2H-4B0N	SV2H-4B0B	SV2H-4F0N	SV2H-4F0B
Price	\$1,311.00	\$2,047.00	\$2,014.00	\$2,760.00	\$2,324.00	\$3,182.00
Drawing	PDF	PDF	PDF	PDF	PDF	PDF
Rated Power [kW]	7.5	7.5	11	11	15	15
Rated Torque [N·m]Note 1	47.74	47.74	70	70	95.4	95.4
Max. Torque [N·m]	93.71	93.71	175	175	224.0	224.0
Rated Speed [rpm]	1500		1500			
Max. Speed [rpm]	3000		2000			
Rated current [Amps] rms	28.7	28.7	26.8	26.8	37.5	37.5
Max. Instantaneous Current [Amps] rms	57.69	57.69	67.7	67.7	95.3	95.3
Change of Rated Power [W/s]	159.7	156.6	145.0	141.4	201.8	197.1
Rotor Inertia [x10 ⁻⁴ kg m ²]	142.7	145.5	338	346.5	451	461.8
Mechanical Time Constant [ms]	0.81	0.83	1.40	1.44	1.21	1.23
Torque Constant-KT [N·m/A]	1.663	1.663	2.612	2.612	2.544	2.544
Voltage Constant-KE [mV/rpm]	66.40	66.40	96.00	96.00	83.90	83.90
Armature Resistance [Ohm]	0.06	0.06	0.0994	0.0994	0.0545	0.0545
Armature Inductance [mH]	1.70	1.70	2.51	2.51	1.43	1.43
Electrical Time Constant [ms]	28.33	28.33	25.25	25.25	26.24	26.24
Insulation Class	Class A (UL), Class B (CE)		Class F (UL), Class F (CE)			
Insulation Resistance	> 100 MΩ, 500VDC					
Insulation Strength	2.3 kVAC, 1 sec					
Weight [kg]	40.5	46	56.4	68.4	75	87
Max. Radial Loading [N]	1764		3300			
Max. Axial Loading [N]	588		1100			
Brake Holding Torque [N·m (min)]Note 2	n/a	55	n/a	115	n/a	115
Brake Power Consumption (at 20°C) [W]		19.9		28.8		28.8
Brake Release Time [ms (max)]		10		10		10
Brake Pull-in Time [ms (max)]		70		70		70
Vibration Grade [μm]	V15					
Operating Temperature [°C]	0–40 °C (32–104 °F)					
Storage Temperature [°C]	-10°C to 80°C (-14°F to 176°F)					
Operating Humidity	20–90% relative humidity (non-condensing)					
Storage Humidity	20–90% relative humidity (non-condensing)					
Vibration Capacity	2.5 G					
IP Rating	IP65 (when using waterproof connectors and when an oil seal is fitted to the rotating shaft (for an oil seal model))					
Encoder Resolution	24-bit (16777216 p/rev)					
Agency Approvals	cUR _{US} , CE					

Note 1–The rated torque is the continuous permissible torque between the 0°C and 40°C operating temperature which is suitable for a servo motor mounted with the following heat sink dimensions:

300mm x 300mm x 12mm

400mm x 400mm x 20mm

550mm x 550mm x 30mm

All made from aluminum (or mounted to equipment with an equivalent heat sinking capability)

Note 2–The built-in servo motor brake is only for holding the load in a stopped state. Do not use it for deceleration or as a dynamic brake.

Standard wiring example, 230V Systems

24V Open-collector pulse command input

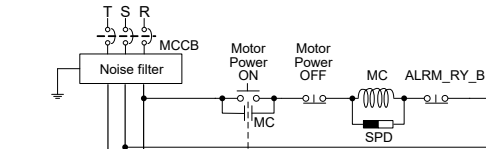
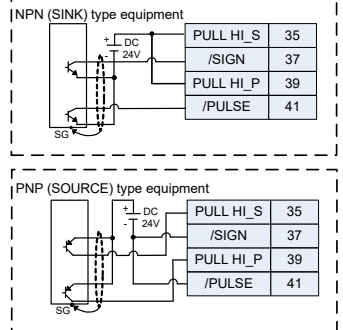

Inputs SIGN (36) and PULSE (43) are designed for Line Driver (differential) signals. Do not use with 24V. For 5V open collector applications, see section 3.5 in the User Manual.

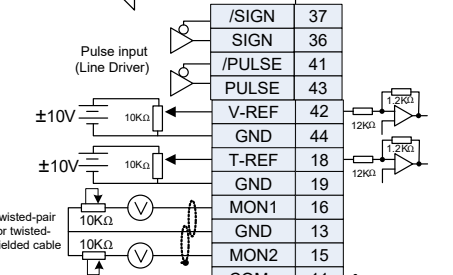

Digital Input Rating:
ON: 15 - 24V_{DC}, 8mA
OFF: <5V_{DC}, <0.5 mA

Digital Output Rating:
Max 30V_{DC}, Max 40mA

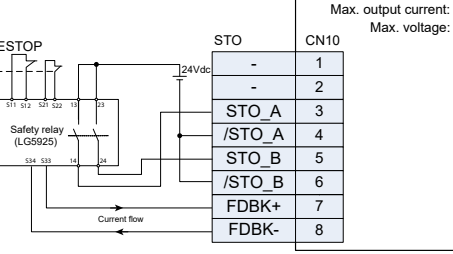
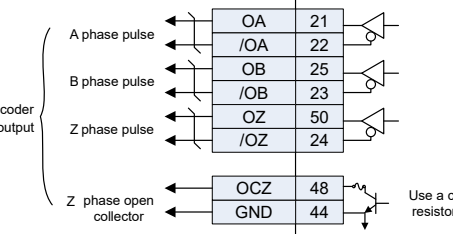
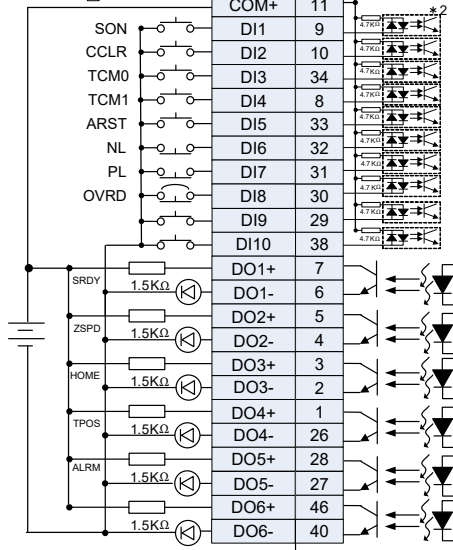
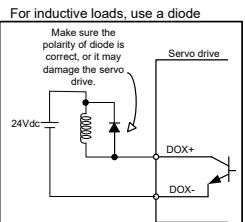

NOTE: Polarity between terminals S33/S34 and FDBK+/- must be correct. If polarity is reversed, enough leakage current will flow through the drive transistor to satisfy the reset circuit of the safety relay.

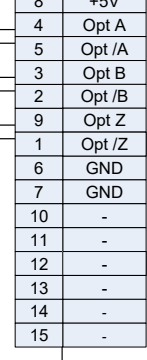
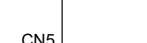
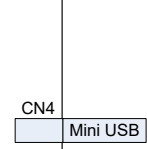
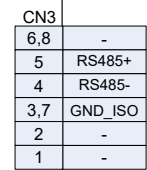
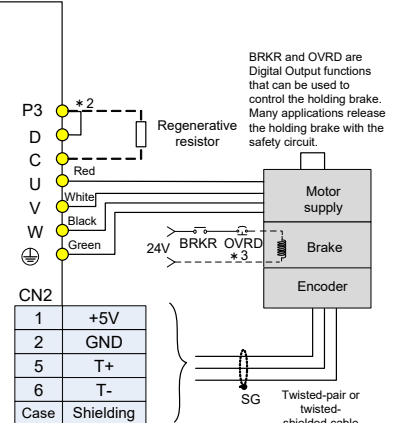

This wiring diagram shows basic wiring only, and additional wiring configurations are possible for some I/O. Refer to the "Installation and Wiring" chapter of the User Manual for more detailed wiring information.

Standard wiring example, 460V Systems

This wiring diagram shows basic wiring only, and additional wiring configurations are possible for some I/O. Refer to the "Installation and Wiring" chapter of the User Manual for more detailed wiring information.

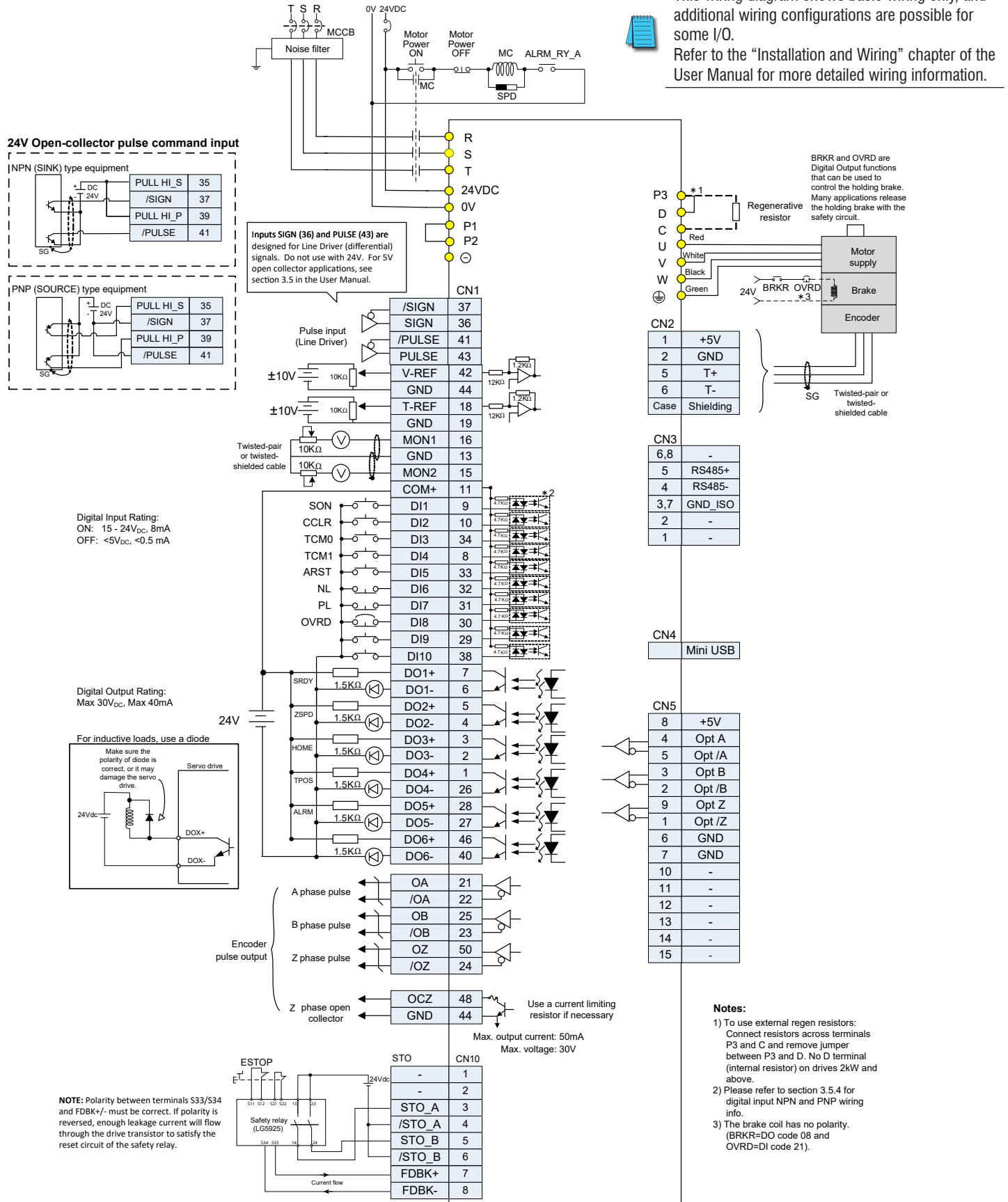

Servo drive dimensions

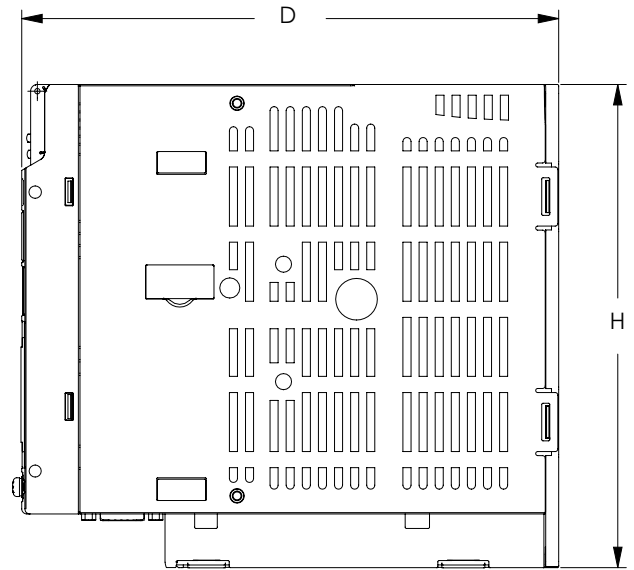
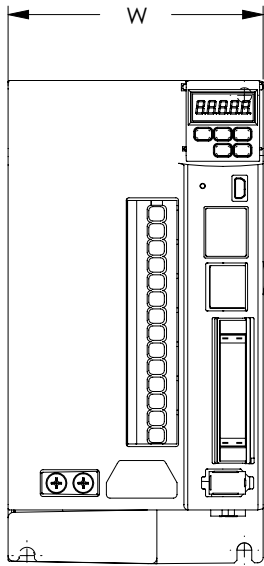

SureServo2 Drive Dimensions				
Model	Drawing Link	W mm [inches]	D mm [inches]	H mm [inches]
SV2A-2040	PDF	35 [1.38]	170 [6.69]	170 [6.69]
SV2A-2075	PDF	50 [1.97]	180 [7.09]	180 [7.09]
SV2A-2150	PDF	50 [1.97]	180 [7.09]	180 [7.09]
SV2A-2200	PDF	95 [3.74]	200 [7.87]	180 [7.09]
SV2A-2300	PDF	95 [3.74]	200 [7.87]	180 [7.09]
SV2A-2550	PDF	120 [4.72]	206 [8.12]	273 [10.75]
SV2A-2750	PDF	141 [5.56]	226 [8.90]	312 [12.28]
SV2A-2F00	PDF	186 [7.32]	281 [11.08]	390 [15.35]
SV2A-4040	PDF	65 [2.55]	204 [8.03]	180 [7.09]
SV2A-4075	PDF	65 [2.55]	204 [8.03]	180 [7.09]
SV2A-4150	PDF	65 [2.55]	204 [8.03]	180 [7.09]
SV2A-4200	PDF	110 [4.33]	200.8 [7.9]	260 [10.24]
SV2A-4300	PDF	110 [4.33]	200.8 [7.9]	260 [10.24]
SV2A-4550	PDF	110 [4.33]	200.8 [7.9]	260 [10.24]
SV2A-4750	PDF	120 [4.72]	206.3 [8.12]	273 [10.75]
SV2A-4F00	PDF	141 [5.55]	225.5 [8.88]	312 [12.28]



For additional dimensions, see the AutomationDirect website or click on the drawing links.



Requires 2" above and below the drive for air flow. For proper air flow clearance, please see section 2.3.1 of the SureServo2 User Manual.



For cabinet depth, add approximately 100mm (4 inches) for CN1 (I/O) and CN2 (encoder) cable bend radius.



AC Servo System Dimensions

230V Servo motor dimensions

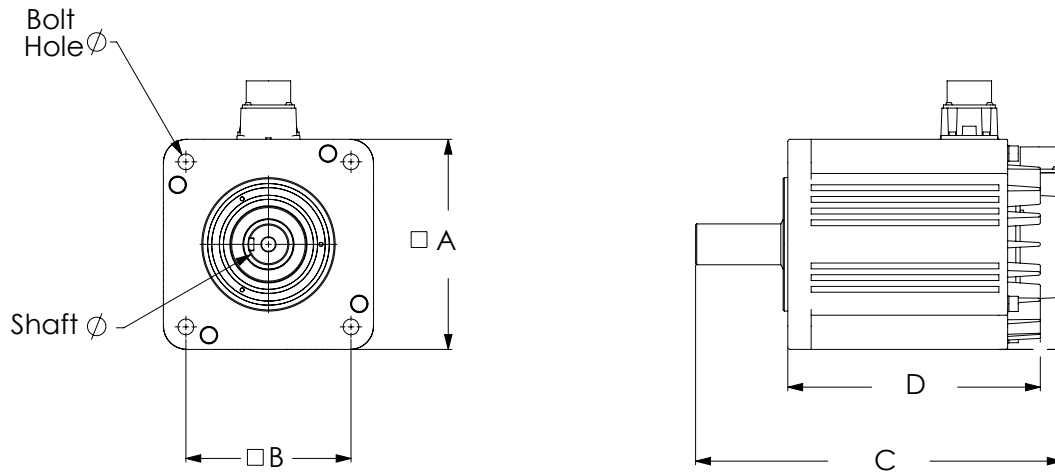

SureServo2 230V Motor Dimensions							
Model	Drawing Link	A mm [inches]	B mm [inches]	C mm [inches]	D mm [inches]	Bolt Hole Ø mm [inches]	Shaft Ø mm [inches]
SV2L-201N	PDF	40.0 [1.57]	32.2 [1.27]	110.3 [4.34]	85.3 [3.36]	4.5 [0.18]	8.0 [0.31]
SV2L-201B	PDF	40.0 [1.57]	32.2 [1.27]	145.1 [5.71]	120.1 [4.73]	4.5 [0.18]	8.0 [0.31]
SV2L-202N	PDF	60.0 [2.36]	49.5 [1.95]	113.9 [4.49]	84.0 [3.31]	5.5 [0.22]	14.0 [0.55]
SV2L-202B	PDF	60.0 [2.36]	49.5 [1.95]	147.6 [5.81]	117.1 [4.61]	5.5 [0.22]	14.0 [0.55]
SV2L-204N	PDF	60.0 [2.36]	49.5 [1.95]	136.0 [5.35]	106.0 [4.17]	5.5 [0.22]	14.0 [0.55]
SV2L-204B	PDF	60.0 [2.36]	49.5 [1.95]	169.7 [6.68]	139.7 [5.50]	5.5 [0.22]	14.0 [0.55]
SV2L-207N	PDF	80.0 [3.15]	63.6 [2.51]	155.8 [6.13]	115.8 [4.56]	6.6 [2.51]	19.0 [0.75]
SV2L-207B	PDF	80.0 [3.15]	63.6 [2.51]	193.2 [7.61]	153.2 [6.03]	6.6 [2.51]	19.0 [0.75]
SV2L-210N	PDF	100.0 [3.94]	81.3 [3.20]	198.3 [7.81]	110.2 [4.34]	9.0 [0.35]	22.0 [0.87]
SV2L-210B	PDF	100.0 [3.94]	81.3 [3.20]	237.5 [9.35]	149.5 [5.89]	9.0 [0.35]	22.0 [0.87]
SV2M-210N	PDF	130.0 [5.12]	102.5 [4.04]	202.5 [7.97]	104.5 [4.11]	9.0 [0.35]	22.0 [0.87]
SV2M-210B	PDF	130.0 [5.12]	102.5 [4.04]	238.5 [9.39]	140.5 [5.53]	9.0 [0.35]	22.0 [0.87]
SV2M-215N	PDF	130.0 [5.12]	102.5 [4.04]	222.5 [8.76]	120.5 [4.74]	9.0 [0.35]	22.0 [0.87]
SV2M-215B	PDF	130.0 [5.12]	102.5 [4.04]	257.0 [10.12]	155.0 [6.10]	9.0 [0.35]	22.0 [0.87]
SV2M-220N	PDF	180.0 [7.09]	141.4 [5.57]	247.7 [9.75]	150.0 [5.91]	13.5 [0.53]	35.0 [1.38]
SV2M-220B	PDF	180.0 [7.09]	141.4 [5.57]	281.8 [11.09]	184.1 [7.25]	13.5 [0.53]	35.0 [1.38]
SV2M-230N	PDF	180.0 [7.09]	141.4 [5.57]	280.8 [11.06]	183.1 [7.21]	13.5 [0.53]	35.0 [1.38]
SV2M-230B	PDF	180.0 [7.09]	141.4 [5.57]	314.0 [12.36]	216.3 [8.52]	13.5 [0.53]	35.0 [1.38]
SV2H-245N	PDF	180.0 [7.09]	141.4 [5.57]	314.0 [12.36]	216.3 [8.52]	13.5 [0.53]	35.0 [1.38]
SV2H-245B	PDF	180.0 [7.09]	141.4 [5.57]	358.0 [14.09]	260.3 [10.25]	13.5 [0.53]	35.0 [1.38]
SV2H-255N	PDF	180.0 [7.09]	141.4 [5.57]	392.4 [15.45]	260.7 [10.26]	13.5 [0.53]	42.0 [1.63]
SV2H-255B	PDF	180.0 [7.09]	141.4 [5.57]	424.4 [16.71]	292.7 [11.52]	13.5 [0.53]	42.0 [1.63]
SV2H-275N	PDF	180.0 [7.09]	141.4 [5.57]	454.7 [17.9]	323.0 [12.72]	13.5 [0.53]	42.0 [1.63]
SV2H-275B	PDF	180.0 [7.09]	141.4 [5.57]	488.8 [19.24]	357.1 [14.06]	13.5 [0.53]	42.0 [1.63]
SV2H-2B0N	PDF	219.9 [8.66]	166.2 [6.54]	487.4 [19.19]	319.0 [12.56]	13.5 [0.53]	42.0 [1.63]
SV2H-2B0B	PDF	219.9 [8.66]	166.2 [6.54]	550.4 [21.67]	382.0 [15.04]	13.5 [0.53]	42.0 [1.63]
SV2H-2F0N	PDF	219.9 [8.66]	166.2 [6.54]	566.4 [22.30]	398.0 [15.67]	13.5 [0.53]	55.0 [2.17]
SV2H-2F0B	PDF	219.9 [8.66]	166.2 [6.54]	629.4 [24.78]	461.0 [18.15]	13.5 [0.53]	55.0 [2.17]



NOTE: Motor cables are approximately 304mm (12") in length.



For additional dimensions, see the AutomationDirect website or click on the drawing links.

460V Servo motor dimensions

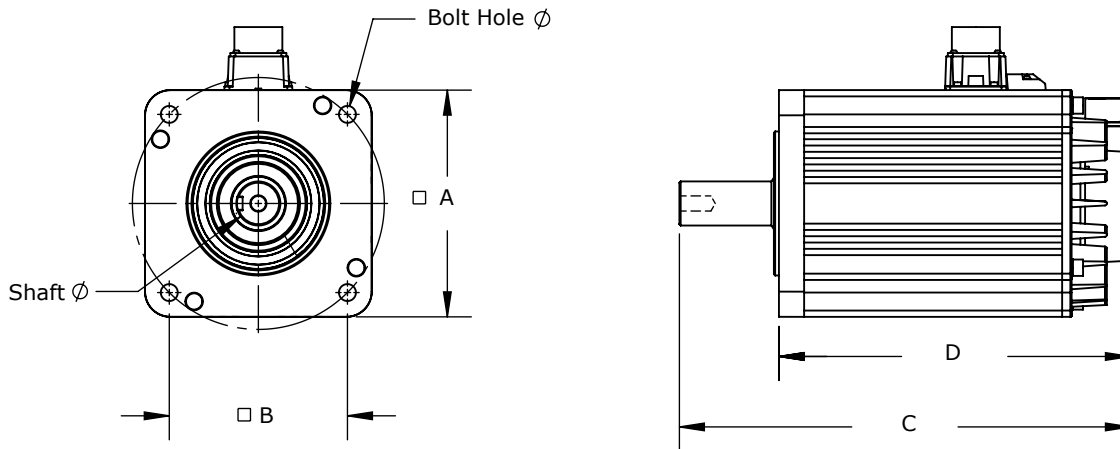

SureServo2 460V Motor Dimensions

Model	Drawing Link	A mm [inches]	B mm [inches]	C mm [inches]	D mm [inches]	Bolt Hole Ø mm [inches]	Shaft Ø mm [inches]
SV2L-404N	PDF	60.0 [2.36]	49.5 [1.95]	136.0 [5.35]	106.0 [4.17]	5.5 [0.22]	14.0 [0.55]
SV2L-404B	PDF	60.0 [2.36]	49.5 [1.95]	169.7 [6.68]	139.7 [5.50]	5.5 [0.22]	14.0 [0.55]
SV2L-407N	PDF	80.0 [3.15]	63.6 [2.51]	155.8 [6.13]	115.8 [4.56]	6.6 [0.26]	19.0 [0.75]
SV2L-407B	PDF	80.0 [3.15]	63.6 [2.51]	193.2 [7.61]	153.2 [6.03]	6.6 [0.26]	19.0 [0.75]
SV2L-410N	PDF	100.0 [3.94]	81.3 [3.20]	198.2 [7.81]	153.2 [6.03]	9.0 [0.35]	22.0 [0.87]
SV2L-410B	PDF	100.0 [3.94]	81.3 [3.20]	237.5 [9.35]	192.5 [7.58]	9.0 [0.35]	22.0 [0.87]
SV2L-415N	PDF	130.0 [5.12]	102.5 [4.04]	222.5 [8.76]	167.5 [6.59]	9.0 [0.35]	22.0 [0.87]
SV2L-415B	PDF	130.0 [5.12]	102.5 [4.04]	257.0 [10.12]	202.0 [7.95]	9.0 [0.35]	22.0 [0.87]
SV2L-420N	PDF	130.0 [5.12]	102.5 [4.04]	242.5 [9.55]	187.5 [7.38]	9.0 [0.35]	22.0 [0.87]
SV2L-420B	PDF	130.0 [5.12]	102.5 [4.04]	271.0 [10.67]	216.0 [8.50]	9.0 [0.35]	22.0 [0.87]
SV2M-410N	PDF	130.0 [5.12]	102.5 [4.04]	202.5 [7.97]	147.5 [5.81]	9.0 [0.35]	22.0 [0.87]
SV2M-410B	PDF	130.0 [5.12]	102.5 [4.04]	238.5 [9.39]	183.5 [7.22]	9.0 [0.35]	22.0 [0.87]
SV2H-430N	PDF	180.0 [7.09]	141.4 [5.57]	280.8 [11.06]	201.8 [7.94]	13.5 [0.53]	35.0 [1.38]
SV2H-430B	PDF	180.0 [7.09]	141.4 [5.57]	314.0 [12.36]	235.0 [9.25]	13.5 [0.53]	35.0 [1.38]
SV2H-445N	PDF	180.0 [7.09]	141.4 [5.57]	314.0 [12.36]	235.0 [9.25]	13.5 [0.53]	35.0 [1.38]
SV2H-445B	PDF	180.0 [7.09]	141.4 [5.57]	358.0 [14.09]	279.0 [10.98]	13.5 [0.53]	35.0 [1.38]
SV2H-455N	PDF	180.0 [7.09]	141.4 [5.57]	392.4 [15.45]	279.4 [11.00]	13.5 [0.53]	42.0 [1.65]
SV2H-455B	PDF	180.0 [7.09]	141.4 [5.57]	424.4 [16.71]	311.4 [12.26]	13.5 [0.53]	42.0 [1.65]
SV2H-475N	PDF	180.0 [7.09]	141.4 [5.57]	454.7 [17.90]	341.7 [13.45]	13.5 [0.53]	42.0 [1.65]
SV2H-475B	PDF	180.0 [7.09]	141.4 [5.57]	488.8 [19.24]	375.8 [14.80]	13.5 [0.53]	42.0 [1.65]
SV2H-4B0N	PDF	220.0 [8.66]	166.2 [6.54]	487.4 [19.19]	371.4 [14.62]	13.5 [0.53]	42.0 [1.65]
SV2H-4B0B	PDF	220.0 [8.66]	166.2 [6.54]	550.4 [21.67]	434.4 [17.10]	13.5 [0.53]	42.0 [1.65]
SV2H-4F0N	PDF	220.0 [8.66]	166.2 [6.54]	566.4 [22.30]	450.4 [17.73]	13.5 [0.53]	55.0 [2.17]
SV2H-4F0B	PDF	220.0 [8.66]	166.2 [6.54]	629.4 [24.78]	513.4 [20.21]	13.5 [0.53]	55.0 [2.17]



NOTE: Motor cables are approximately 304mm (12") in length.



For additional dimensions, see the AutomationDirect website or click on the drawing links.



AC Servo System Accessories

Accessories

CN1 Accessories

The terminal block module and direct mount feedthrough module allow for I/O connections to a SureServo2 drive.

Option 1:

Select an SV2-CN1-CBL50 cable (3 lengths available) and the DIN rail mount SV2-CN1-RTB50 Remote Terminal Block for access to all 50 of the drive's digital and analog I/O signals.

Option 2:

Select the SV2-CN1-LTB20 Local Terminal Block. The LTB20 can be used in many applications and allows connection to the most frequently-used I/O: High speed line driver pulse inputs (Pulse and Direction, AB Quad, etc.), (5) Digital Inputs, (4) Digital Outputs, and the Z-pulse open collector output.

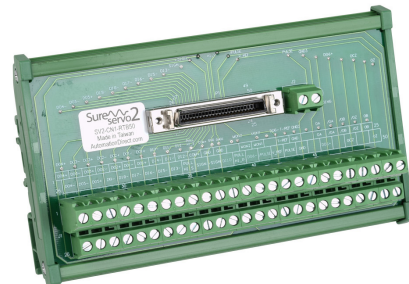

SV2-CN1-RTB50

Part Number	Price	Description	Cable Length	Drawing	Compatible Drives
<u>SV2-CN1-RTB50</u>	\$58.00	SureServo2 feedthrough module, 50-pole, DIN rail mount	-	<u>PDF</u>	All
<u>SV2-CN1-CBL50</u>	\$71.00	SureServo2 CN1 I/O control cable with mating connectors	0.5 m	-	
<u>SV2-CN1-CBL50-1</u>	\$75.00		1m		
<u>SV2-CN1-CBL50-2</u>	\$79.00		2m		
<u>SV2-CN1-LTB20</u>	\$43.00	SureServo2 feedthrough module, 20-pole, direct mount	-	<u>PDF</u>	



SV2-CN1-LTB20

Communication Modules

SureServo2 drives can also make use of optional communication cards. Both EtherNet/IP and Modbus TCP cards are available. Field upgradeable firmware ensures that the cards can always be kept current.

ModBus TCP

The SV2-CM-MODTCP Modbus TCP card allows the same access to all the drive parameters as the native serial Modbus (RS485).

EtherNet/IP

The SV2-CM-ENETIP Ethernet/IP card allows both Explicit and Implicit (I/O) Messaging. The SureServo2 Pro software allows you to easily generate (with pull-down menus) an EDS file for import into your PLC that contains exactly what you want in your Implicit Message.



SV2-CM-ENETIP
or
SV2-CM-MODTCP

Part Number	Price	Description	Drawing	Compatible Drives
<u>SV2-CM-ENETIP</u>	\$107.00	SureServo2 communication module, EtherNet/IP, 1 port, (1) Ethernet (RJ45) port.	<u>PDF</u>	All SureServo2 drives
<u>SV2-CM-MODTCP</u>	\$97.00	SureServo2 communication module, Modbus TCP, 1 port, (1) Ethernet (RJ45) port.	<u>PDF</u>	



AC Servo System Accessories

Accessories, continued

Motor Cables

Use the table to the right to select the correct SV2 motor cables (power, encoder, and brake) for your SureServo2 motor. Note that the largest frame brakemotors require a separate brake cable: 230V motors 5.5–15 kW and 460V motors 11kW–15kW. For smaller brakemotors, the brake wiring is incorporated into the motor power cable.

First find the motor part number in the left column, then reference the required cable part series under the Power, Encoder, and Brake columns. The first two "x" digits in the part numbers below are placeholders to represent length in meters while the 3rd "x" denotes flex (F) or non-flex (N) cabling. Brake vs non-brake cables are represented by a "B" or "N" at the end of the part number. For example, a 20m non-flex non-brake cable would end in 20NN, while a 3m flex-rated brake motor cable would end in 03FB. Note that SV2H series motors (5.5 kW and greater) use a separate cable to power the brake, so use an "N" cable for motor power. Also, if you use a flex-rated power cable (F series) you should use flex-rated encoder and brake power cables. The flex cables may not feel more flexible when compared side-by-side with the non-flex versions, but they are constructed with finer strands of wire and are designed to withstand millions of flex cycles (continuous flexing) without suffering from "cable corkscrew".

Specs and prices for the various cable options in each series can be found in the tables on the following pages.

Example:

You are purchasing an SV2L-201B brake motor and want 10m flex-rated cabling. What cables do you need? The abbreviated motor chart below shows that the SV2L-201B brake motor needs a PB18 series power cable and an E122 series encoder cable. Brake power is supplied through the power cable. The cable charts on subsequent pages enumerate all the various options and show that a 10m, flex, E122 series encoder cable is SV2C-E122-10FN and that a 10m, flex, PB series power cable is SV2C-PB18-10FB.

SureServo2® Motor		Power Cable	Encoder Cable	Brake Cable
230V	460V			
SV2L-201N SV2L-202N SV2L-204N SV2L-207N	SV2L-404N SV2L-407N	SV2C-PA18-xxxN	SV2C-E122-xxxN	n/a
SV2L-201B SV2L-202B SV2L-204B SV2L-207B	SV2L-404B SV2L-407B	SV2C-PB18-xxxB		
SV2L-210N	SV2L-410N SV2M-410N SV2L-415N SV2L-420N	SV2C-PC16-xxxN		
SV2L-210B	SV2L-410B SV2M-410B SV2L-415B SV2L-420B	SV2C-PC16-xxxB		
SV2M-210N SV2M-215N	–	SV2C-PC12-xxxN		
SV2M-210B SV2M-215B	–	SV2C-PC12-xxxB		
SV2M-220N SV2M-230N	SV2H-430N	SV2C-PD12-xxxN		
SV2M-220B SV2M-230B	SV2H-430B	SV2C-PD12-xxxB		
SV2H-245N	SV2H-445N SV2H-455N SV2H-475N	SV2C-PD08-xxxN	SV2C-E222-xxxN	
SV2H-245B	SV2H-445B SV2H-455B SV2H-475B	SV2C-PD08-xxxB		
SV2H-255N SV2H-275N SV2H-2B0N	–	SV2C-PF06-xxxN	SV2C-B120-xxxB	
SV2H-255B SV2H-275B SV2H-2B0B	–	SV2C-PF06-xxxN		
SV2H-2F0N	–	SV2C-PF04-xxxN		n/a
SV2H-2F0B	–	SV2C-PF04-xxxN		SV2C-B120-xxxB
–	SV2H-4B0N SV2H-4F0N	SV2C-PF08-xxxN		n/a
–	SV2H-4B0B SV2H-4F0B	SV2C-PF08-xxxN		SV2C-B120-xxxB



Power Cables

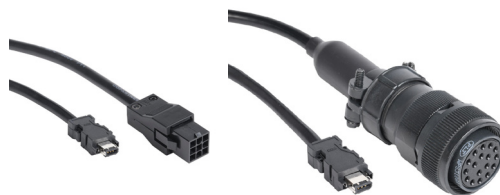

Encoder Cables



Separate Brake Cable
(for large frame motors (see table))



AC Servo System Accessories

Accessories, continued

SV2C-E122 Series Encoder Cables

Part Number	Price	Flex Rated	Length	Gauge	Drawing	Connector	Compatible Motors
SV2C-E122-03NN	\$60.00	N	3m	22	PDF	SV2C-E1-CON	SV2L-201x SV2L-202x SV2L-204x SV2L-207x SV2L-404x SV2L-407x
SV2C-E122-05NN	\$82.00		5m		PDF		
SV2C-E122-10NN	\$130.00		10m		PDF		
SV2C-E122-20NN	\$213.00		20m		PDF		
SV2C-E122-03FN	\$77.00	Y	3m		PDF		
SV2C-E122-05FN	\$109.00		5m		PDF		
SV2C-E122-10FN	\$182.00		10m		PDF		
SV2C-E122-20FN	\$316.00		20m		PDF		

SV2C-E222 Series Encoder Cables

Part Number	Price	Flex Rated	Length	Gauge	Drawing	Connector	Compatible Motors	
SV2C-E222-03NN	\$130.00	N	3m	22	PDF	SV2C-E2-CON	SV2L-210x	SV2L-410x
SV2C-E222-05NN	\$213.00		5m		PDF		SV2M-210x	SV2M-410x
SV2C-E222-10NN	\$265.00		10m		PDF		SV2M-215x	SV2L-415x
SV2C-E222-20NN	\$350.00		20m		PDF		SV2M-220x	SV2L-420x
SV2C-E222-03FN	\$168.00	Y	3m		PDF		SV2M-230x	SV2H-430x
SV2C-E222-05FN	\$206.00		5m		PDF		SV2H-245x	SV2H-445x
SV2C-E222-10FN	\$317.00		10m		PDF		SV2H-255x	SV2H-455x
SV2C-E222-20FN	\$453.00		20m		PDF		SV2H-275X	SV2H-475X
							SV2H-2B0x	SV2H-4B0x
							SV2H-2F0x	SV2H-4F0x

SV2C-PA18 Series Power Cables

Part Number	Price	Flex Rated	Length	Gauge	Drawing	Connector	Compatible Motors
SV2C-PA18-03NN	\$41.00	N	3m	18	PDF	SV2C-PA-CON	SV2L-201N SV2L-202N SV2L-204N SV2L-207N SV2L-404N SV2L-407N
SV2C-PA18-05NN	\$54.00		5m		PDF		
SV2C-PA18-10NN	\$80.00		10m		PDF		
SV2C-PA18-20NN	\$128.00		20m		PDF		
SV2C-PA18-03FN	\$57.00	Y	3m		PDF		
SV2C-PA18-05FN	\$77.00		5m		PDF		
SV2C-PA18-10FN	\$124.00		10m		PDF		
SV2C-PA18-20FN	\$212.00		20m		PDF		



AC Servo System Accessories

Accessories, continued

SV2C-PB18 Series Power Cables

Part Number	Price	Flex Rated	Length	Gauge	Drawing	Connector	Compatible Motors
SV2C-PB18-03NB	\$48.00	N	3m	18	PDF	SV2C-PB-CON	SV2L-201B SV2L-202B SV2L-204B SV2L-207B SV2L-404B SV2L-407B
SV2C-PB18-05NB	\$63.00		5m		PDF		
SV2C-PB18-10NB	\$100.00		10m		PDF		
SV2C-PB18-20NB	\$163.00		20m		PDF		
SV2C-PB18-03FB	\$72.00	Y	3m		PDF		
SV2C-PB18-05FB	\$105.00		5m		PDF		
SV2C-PB18-10FB	\$176.00		10m		PDF		
SV2C-PB18-20FB	\$313.00		20m		PDF		

SV2C-PC16 Series Power Cables

Part Number	Price	Flex Rated	Length	Gauge	Drawing	Connector	Compatible Motors
SV2C-PC16-03NN	\$140.00	N	3m	16	PDF	SV2C-PC-CON	SV2L-210N SV2L-410N SV2M-410N SV2L-415N SV2L-420N
SV2C-PC16-05NN	\$166.00		5m		PDF		
SV2C-PC16-10NN	\$219.00		10m		PDF		
SV2C-PC16-20NN	\$318.00		20m		PDF		
SV2C-PC16-03FN	\$154.00	Y	3m		PDF		
SV2C-PC16-05FN	\$186.00		5m		PDF		
SV2C-PC16-10FN	\$261.00		10m		PDF		
SV2C-PC16-20FN	\$401.00		20m		PDF		
SV2C-PC16-03NB	\$164.00	N	3m	16	PDF	SV2C-PC-CON	SV2L-210B SV2L-410B SV2M-410B SV2L-415B SV2L-420B
SV2C-PC16-05NB	\$198.00		5m		PDF		
SV2C-PC16-10NB	\$274.00		10m		PDF		
SV2C-PC16-20NB	\$415.00		20m		PDF		
SV2C-PC16-03FB	\$184.00	Y	3m		PDF		
SV2C-PC16-05FB	\$230.00		5m		PDF		
SV2C-PC16-10FB	\$335.00		10m		PDF		
SV2C-PC16-20FB	\$537.00		20m		PDF		



AC Servo System Accessories

Accessories, continued

SV2C-PC12 Series Power Cables

Part Number	Price	Flex Rated	Length	Gauge	Drawing	Connector	Compatible Motors	
SV2C-PC12-03NN	\$192.00	N	3m	12	PDF	SV2C-PC-CON	SV2M-210N SV2M-215N	
SV2C-PC12-05NN	\$251.00		5m		PDF			
SV2C-PC12-10NN	\$391.00		10m		PDF			
SV2C-PC12-20NN	\$659.00		20m		PDF			
SV2C-PC12-03FN	\$210.00	Y	3m		PDF			
SV2C-PC12-05FN	\$279.00		5m		PDF			
SV2C-PC12-10FN	\$443.00		10m		PDF			
SV2C-PC12-20FN	\$760.00		20m		PDF			
SV2C-PC12-03NB	\$213.00	N	3m	12	PDF		SV2C-PC-CON	SV2M-210B SV2M-215B
SV2C-PC12-05NB	\$280.00		5m		PDF			
SV2C-PC12-10NB	\$442.00		10m		PDF			
SV2C-PC12-20NB	\$752.00		20m		PDF			
SV2C-PC12-03FB	\$235.00	Y	3m		PDF			
SV2C-PC12-05FB	\$316.00		5m		PDF			
SV2C-PC12-10FB	\$513.00		10m		PDF			
SV2C-PC12-20FB	\$892.00		20m		PDF			

SV2C-PD12 Series Power Cables

Part Number	Price	Flex Rated	Length	Gauge	Drawing	Connector	Compatible Motors	
SV2C-PD12-03NN	\$175.00	N	3m	12	PDF	SV2C-PD-CON	SV2M-220N SV2M-230N SV2H-430N	
SV2C-PD12-05NN	\$223.00		5m		PDF			
SV2C-PD12-10NN	\$342.00		10m		PDF			
SV2C-PD12-20NN	\$570.00		20m		PDF			
SV2C-PD12-03FN	\$188.00	Y	3m		PDF			
SV2C-PD12-05FN	\$246.00		5m		PDF			
SV2C-PD12-10FN	\$386.00		10m		PDF			
SV2C-PD12-20FN	\$655.00		20m		PDF			
SV2C-PD12-03NB	\$194.00	N	3m	12	PDF		SV2C-PD-CON	SV2M-220B SV2M-230B SV2H-430B
SV2C-PD12-05NB	\$251.00		5m		PDF			
SV2C-PD12-10NB	\$386.00		10m		PDF			
SV2C-PD12-20NB	\$649.00		20m		PDF			
SV2C-PD12-03FB	\$212.00	Y	3m		PDF			
SV2C-PD12-05FB	\$281.00		5m		PDF			
SV2C-PD12-10FB	\$447.00		10m		PDF			
SV2C-PD12-20FB	\$768.00		20m		PDF			



AC Servo System Accessories

Accessories, continued

SV2C-PD08 Series Power Cables

Part Number	Price	Flex Rated	Length	Gauge	Drawing	Connector	Compatible Motors	
SV2C-PD08-03NN	\$238.00	N	3m	8	PDF	SV2C-PD-CON	SV2H-245N SV2H-445N SV2H-455N SV2H-475N	
SV2C-PD08-05NN	\$325.00		5m		PDF			
SV2C-PD08-10NN	\$544.00		10m		PDF			
SV2C-PD08-20NN	\$970.00		20m		PDF			
SV2C-PD08-03FN	\$258.00	Y	3m		PDF			
SV2C-PD08-05FN	\$360.00		5m		PDF			
SV2C-PD08-10FN	\$612.00		10m		PDF			
SV2C-PD08-20FN	\$1,108.00		20m		PDF			
SV2C-PD08-03NB	\$231.00	N	3m	8	PDF		SV2C-PD-CON	SV2H-245B SV2H-445B SV2H-455B SV2H-475B
SV2C-PD08-05NB	\$326.00		5m		PDF			
SV2C-PD08-10NB	\$559.00		10m		PDF			
SV2C-PD08-20NB	\$1,009.00		20m		PDF			
SV2C-PD08-03FB	\$272.00	Y	3m		PDF			
SV2C-PD08-05FB	\$383.00		5m		PDF			
SV2C-PD08-10FB	\$659.00		10m		PDF			
SV2C-PD08-20FB	\$1,192.00		20m		PDF			

SV2C-PF08 Series Power Cables

Part Number	Price	Flex Rated	Length	Gauge	Drawing	Connector	Compatible Motors
SV2C-PF08-03NN	\$241.00	N	3m	8	PDF	SV2C-PF-CON	SV2H-4B0N SV2H-4B0B SV2H-4F0N SV2H-4F0B
SV2C-PF08-05NN	\$297.00		5m		PDF		
SV2C-PF08-10NN	\$433.00		10m		PDF		
SV2C-PF08-20NN	\$750.00		20m		PDF		
SV2C-PF08-03FN	\$305.00	Y	3m		PDF		
SV2C-PF08-05FN	\$401.00		5m		PDF		
SV2C-PF08-10FN	\$633.00		10m		PDF		
SV2C-PF08-20FN	\$1,148.00		20m		PDF		

SV2C-PF06 Series Power Cables

Part Number	Price	Flex Rated	Length	Gauge	Drawing	Connector	Compatible Motors
SV2C-PF06-03NN	\$323.00	N	3m	6	PDF	SV2C-PF-CON	SV2H-255N SV2H-255B SV2H-275N SV2H-275B SV2H-2B0N SV2H-2B0B
SV2C-PF06-05NN	\$478.00		5m		PDF		
SV2C-PF06-10NN	\$833.00		10m		PDF		
SV2C-PF06-20NN	\$1,507.00		20m		PDF		
SV2C-PF06-03FN	\$376.00	Y	3m		PDF		
SV2C-PF06-05FN	\$528.00		5m		PDF		
SV2C-PF06-10FN	\$913.00		10m		PDF		
SV2C-PF06-20FN	\$1,660.00		20m		PDF		



AC Servo System Accessories

Accessories, continued

SV2C-PF04 Series Power Cables

Part Number	Price	Flex Rated	Length	Gauge	Drawing	Connector	Compatible Motors
SV2C-PF04-03NN	\$382.00	N	3m	4	PDF	SV2C-PF-CON	SV2H-2F0N SV2H-2F0B
SV2C-PF04-05NN	\$539.00		5m		PDF		
SV2C-PF04-10NN	\$909.00		10m		PDF		
SV2C-PF04-20NN	\$1,652.00		20m		PDF		
SV2C-PF04-03FN	\$434.00	Y	3m		PDF		
SV2C-PF04-05FN	\$612.00		5m		PDF		
SV2C-PF04-10FN	\$1,064.00		10m		PDF		
SV2C-PF04-20FN	\$1,944.00		20m		PDF		

SV2C-B120 Series Brake Cables

Part Number	Price	Flex Rated	Length	Gauge	Drawing	Connector	Compatible Motors
SV2C-B120-03NB	\$88.00	N	3m	20	PDF	SV2C-B1-CON	SV2H-255B SV2H-275B SV2H-2B0B SV2H-2F0B SV2H-4B0B SV2H-4F0B
SV2C-B120-05NB	\$102.00		5m		PDF		
SV2C-B120-10NB	\$128.00		10m		PDF		
SV2C-B120-20NB	\$172.00		20m		PDF		
SV2C-B120-03FB	\$95.00	Y	3m		PDF		
SV2C-B120-05FB	\$112.00		5m		PDF		
SV2C-B120-10FB	\$149.00		10m		PDF		
SV2C-B120-20FB	\$214.00		20m		PDF		

Accessories, continued

External Encoder CN5 Cables

CN5 secondary encoder cables can be used to connect an external secondary encoder to a SureServo2 drive. The CN5 uses a wire not present in standard VGA cables - you must use one of these cables, standard HD15 VGA cables will not work.

Part Number	Price	Description	Length	Drawing	Compatible Drives
<u>ZL-HD15M-CBL-2P</u>	\$19.00	ZIPLink communication cable, 15-pin D-sub HD15 male to pigtail, shielded, twisted pair.	2m	<u>PDF</u>	All SV2 drives
<u>ZL-HD15M-CBL-DB15F*</u>	\$20.50	ZIPLink communication cable, 15-pin female D-sub to 15-pin D-sub HD15 male, shielded, twisted pair.	2m	<u>PDF</u>	

* ZL-RTB-DB15 is required to use the ZL-HD15M-CBL-DB15F cable

Pin Number	Color	Signal	Function
1	Black/White	Opt_/Z	/Z phase input
2	Blue/White	Opt_/B	/B phase input
3	Blue	Opt_B	B phase input
4	Green	Opt_A	A phase input
5	Green/White	Opt_/A	/A phase input
6	Yellow Yellow/Black	GND	Encoder grounding
7	Red/White	GND	Encoder grounding
8	Red	+5V	Encoder power
9	Black	Opt_Z	Z phase input
10	Orange	Reserved	Reserved
11	Orange/White	Reserved	Reserved
12	Brown	Reserved	Reserved
13	Brown/White	Reserved	Reserved
14	Purple	Reserved	Reserved
15	Purple/White	Reserved	Reserved



ZL-HD15M-CBL-2P



ZL-RTB-DB15



ZL-HD15M-CBL-DB15F



SV2-BBOX-CBL

Battery Box

An optional external battery can be used to power SureServo2 encoders. The battery allows the use of Absolute Encoder Mode. This mode will keep track of the motor actual position (regardless of number of turns) even if control power is removed from the drive.

SV2-BBOX-1 attaches to the encoder cable. There is a small connector protruding from each encoder cable several inches from the drive-end connector. This connector plugs into the SV2-BBOX-1.

SV2-BBOX-CBL is not required for most applications. Use this cable to extend the length from the encoder cable's connector to the BBOX. This is used if you do not want the BBOX clamped onto the encoder cable right under the drive.

Part Number	Price	Description	Length	Drawing	Compatible Drives
<u>SV2-BBOX-1</u>	\$22.50	SureServo2 encoder single battery box, for use with all SureServo2 drives. (1) AA ER14505 lithium battery included.	-	<u>PDF</u>	All SV2 drives
<u>SV2-BBOX-CBL</u>	\$3.00	SureServo2 battery box cable, mating connectors, 7.8 in/200mm cable length. For use with SureServo2 encoder battery box.	200mm	<u>PDF</u>	



SV2-BBOX-1
Motion Control



AC Servo System Accessories

Accessories, continued

Serial Comms Connectors

Available serial comms connectors consist of an RS-485 splitter and an RS-485 terminating resistor. These connectors (and the drive's CN3) all use RJ45 connectors.

With these two connectors, you can easily create a multi-drop RS485 connection with minimal manual wiring. For multi-drop systems, use one SV2-CN3-CON-2 per drive. Connect each drive with a standard RJ45 (Ethernet patch) cable. On the last drive in the daisy-chain, plug in an SV2-CN3-TR2 to terminate the network. On the first drive, either strip one end of a patch cable to wire into your controller/PLC or plug into a ZL-RTB-RJ45 breakout board for easy wiring to your controller/PLC.

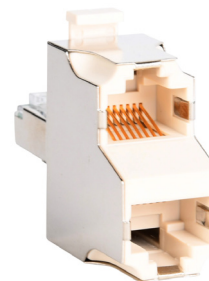

SV2-CN3-CON-2



SV2-CN3-TR2

Part Number	Price	Description	Drawing	Compatible Drives
SV2-CN3-CON-2	\$11.50	SureServo2 splitter, (2) RS-485 (RJ45) to (1) RS-485 (RJ45)	PDF	All SureServo2 Drives
SV2-CN3-TR2	\$5.25	Terminating resistor, 120 ohm, RJ45 8P8C male.	PDF	

Toroid

A toroid (ferrite ring) is available for use with all SureServo2 drives to reduce radiated noise. See the user manual for application information for the SV2-TOR1.



SV2-TOR1

Part Number	Price	Description	Drawing	Compatible Drives
SV2-TOR1	\$13.50	Toroid ring for EMI/RFI filtering (2 per pack)	PDF	All SureServo2 Drives

Cable Connectors

Use the cable connectors below to build your own motor power, brake, or encoder cable.

Part Number	Price	Description	Drawing	Compatible With
SV2C-PA-CON	\$11.50	SureServo2 motor power connector	PDF	750W or smaller SureServo2 motors w/o brake
SV2C-PB-CON	\$13.50		PDF	750W or smaller SureServo2 motors w/brake
SV2C-PC-CON	\$40.00		PDF	All 1 and 1.5 kW and 460V series 2kW SureServo2 motors
SV2C-PD-CON	\$47.00		PDF	230V series 2 to 4.5 kW and 460V series 3 to 7.5 kW SureServo2 motors
SV2C-PF-CON	\$69.00		PDF	230V series 5.5 to 15kW and 460V series 11 and 15kW SureServo2 motors
SV2C-E1-CON	\$10.00	SureServo2 motor encoder connector	PDF	750W or smaller SureServo2 motors
SV2C-E2-CON	\$37.00		PDF	1kW and larger SureServo2 motors
SV2C-E3-CON	\$10.00	CN2 encoder cable (connection to drive)	PDF	All SureServo2 drives
SV2C-B1-CON	\$32.00	SureServo2 motor brake connector	PDF	230V series 5.5 to 15kW and 460V series 11 and 15kW SureServo2 motors with brake

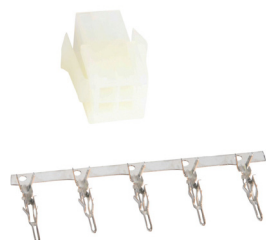

SV2C-PA-CON



SV2C-PF-CON



SV2C-E1-CON

Accessories, continued

Replacement Connectors

The following replacement connectors can be purchased for use with SureServo2 drives. SV2-CN1-CON and SV2-CN10-STO are standalone connectors, while SV2-CON-KIT is a set of connectors.

Part Number	Price	Description	Drawing	Compatible With
<u>SV2-CN1-CON</u>	\$17.50	Optional 50-pin CN1 I/O connector (solder)	-	All SureServo2 drives
<u>SV2-CON-KIT</u>	\$21.50	SureServo2 replacement connector kit, contains: (1) SV2-CN10-STO connector (2) AC power connectors (1) Power resistor connector (1) Motor power connector (2) Wire insert tools	-	Up to 1.5 kW 230V SureServo2 drives (460V drives use integrated terminals)
<u>SV2-CN10-STO</u>	\$10.00	Replacement SureServo2 STO connector	<u>PDF</u>	All SureServo2 drives



SV2-CON-KIT



SV2-CN10-STO



SV2-CN1-CON

Replacement Drive Fans

The following replacement fans can be purchased for use with SureServo2 drives. Each fan can be used to replace the fan on a specific 230 and 460 V drive. Please see the table below to find the correct part.

Part Number	Price	Description
<u>SV2-FAN-1</u>	\$15.00	SureServo2 main cooling fan, replacement, 40 x 40 x 15mm, 12 VDC. For use with SureServo2 SV2A-2075 and SV2A-2150 drives. Electrical connector included.
<u>SV2-FAN-2</u>	\$14.00	SureServo2 main cooling fan, replacement, 50 x 50 x 20mm, 12 VDC. For use with SureServo2 SV2A-2200 and SV2A-2300 drives. Electrical connector included.
<u>SV2-FAN-3</u>	\$23.00	SureServo2 main cooling fan, replacement, 50 x 50 x 20mm, 12 VDC. For use with SureServo2 SV2A-4040, SV2A-4075 and SV2A-4150 drives. Electrical connector included.
<u>SV2-FAN-4</u>	\$24.00	SureServo2 main cooling fan, replacement, 60 x 60 x 25mm, 12 VDC. For use with SureServo2 SV2A-2550, SV2A-4300 and SV2A-4550 drives. Electrical connector included.
<u>SV2-FAN-5</u>	\$19.00	SureServo2 main cooling fan, replacement, 60 x 60 x 20mm, 12 VDC. For use with SureServo2 SV2A-2550, SV2A-4200 and SV2A-4550 drives. Electrical connector included.
<u>SV2-FAN-6</u>	\$27.00	SureServo2 main cooling fan, replacement, 70 x 70 x 25mm, 12 VDC. For use with SureServo2 SV2A-2750 and SV2A-4750 drives. Electrical connector included.
<u>SV2-FAN-7</u>	\$49.00	SureServo2 main cooling fan, replacement, 92 x 92 x 38mm, 24 VDC. For use with SureServo2 SV2A-2F00 drive. Electrical connector included.
<u>SV2-FAN-8</u>	\$38.00	SureServo2 main cooling fan, replacement, 92 x 92 x 38mm, 12 VDC. For use with SureServo2 SV2A-4F00 drive. Electrical connector included.



SV2-FAN-1



SV2-FAN-8