

Dold BH5932 Speed Monitor Relays **DOLD**

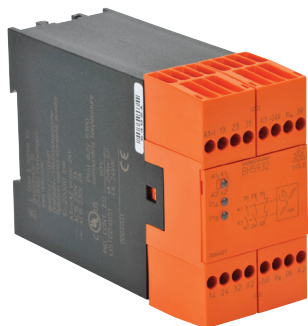

BH5932 speed monitoring safety relay modules use inputs from proximity sensors that are detecting rotating targets on the motor that needs monitoring.

- Energized when speed is under setting value
- Two PNP sensor inputs
- 10 to 20,000 IPM (impulses per minute) adjustable range
- Monitors rotation and linear movement
- 2-channel operation for standstill and over-speed monitoring
- 2 N.O. and 1 N.C. positive-guided contacts
- LED status indicators

Safety Data – Values per EN ISO 13849-1

Category	3 according to EN 954-1
Performance level	PLe according to EN 13849-1
MTTF _d	>273 years
DC _{avg}	99%

Safety Data – Values per IEC/EN 62061 /IEC/EN 61508

SIL CL	3 per IEC/EN 62061
SIL	3 per IEC/EN 61508
HFT (Hardware Failure Tolerance)	1
DC _{avg}	99%
SFF	99.7%
PFH _D	1.69E ⁻¹⁰ h ⁻¹

Safety Speed Monitor Relays Selection Chart

Part Number	Price	Marking Type	Voltage	Outputs
BH5932-22-113-24	\$425.00	Speed-monitoring safety relay module	24 VAC/VDC	2 NO and 1 NC

Safety Speed Monitor Relay Module Specification Table

General Specifications	
Temperature	Storage: -25°C to 85°C (-13°F to 185°F) Operating: -25°C to 60°C (-13°F to 140°F)
Altitude	< 2000m (6562ft)
Vibration Resistance	Amplitude: 0.35mm, Frequency: 10 to 55 Hz (IEC/EN 60-068-2-6)
Degree of Protection	Per IEC/EN 60 529. Housing: IP40; Terminals IP20
Housing	UL 94V-0 Thermoplastic; Din mount 35 mm x 7.5 mm
Weight	410g (14.46 oz)
Agency Approvals and Standards	cULus file E107778, CE, RoHS
Terminal Designation per EN 50 005 Wire Connections	1x4 mm ² solid or 1 x 2.5 mm ² stranded ferruled (isolated) or 2 x 1.5 mm ² stranded ferruled (isolated) DIN 46 228-1/-2/-3/-4 or 2 x 2.5 mm ² solid per DIN 46 228-1/-2/-3 /-4
Wire Fixing	Plus-minus terminal screws M3.5 box terminals with wire protection. Torque 0.8N•m (0.59 lb•ft)
Input Specifications	
Nominal Voltage	24V AC/DC, 110 VAC, 239VAC
Voltage Range	AC: 0.85 to 1.1 UN. At 10% residual ripple: 0.9 to 1.1 UN; At 48% residual ripple: 0.85 to 1.1 UN DC: 0.9 to 1.1 UN. At 10% residual ripple: 0.9 to 1.1 UN; At 48% residual ripple: 0.85 to 1.1 UN
Nominal Consumption	ca. 4VA, 2.5W
Nominal Frequency	50 to 60 Hz. Frequency range: 45 to 65 Hz
Control Current	Control current typ. at 24V over 2 relays: 75mA
Overvoltage Protection	Internal VDR (Voltage Dependent Resistor)
Sensor Inputs	24VDC; 25mA max./3 mA min. per channel.; 1ms On/1ms Off min. pulse time; 30,000 lpm max. at inputs INA and INB
Output Specifications	
Electrical Contact Life	To AC15 at 2A, 230V: 3x10 ⁵ switching cycles IEC/EN 60 947-5-1
Mechanical Life	M50 x 10 ⁶ switching cycles
Contact Type	2 NO positively driven and 1 NC relay contacts (NO contacts are safety contacts)
Operate Delay on Standstill	Depends on setting; see manual and supplement
Release Delay on Overspeed	t _{off} = typ. 350ms
Nominal Output Voltage	250VAC
Thermal Current (I _{th})	Max. 4A per contact. See continuous current limit curve in installation manual.
Short Circuit Strength	Max fuse rating: 4A gl (IEC/EN 60 9470-5-1)
Switching Capacity IEC/EN 60 947-5-1	AC 15: NO contacts: 3A/230V; NC contacts: 2A/230VAC
Switching Frequency	Max. 1200 switching cycles/hr

Dimensions

mm [in]

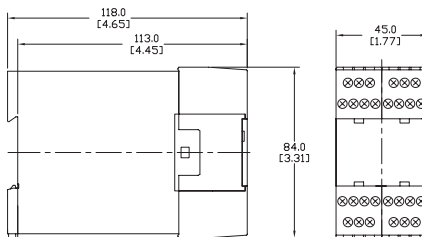

Dold BH5932 Speed Monitor Relays



Wiring

BH5932 Block Diagram

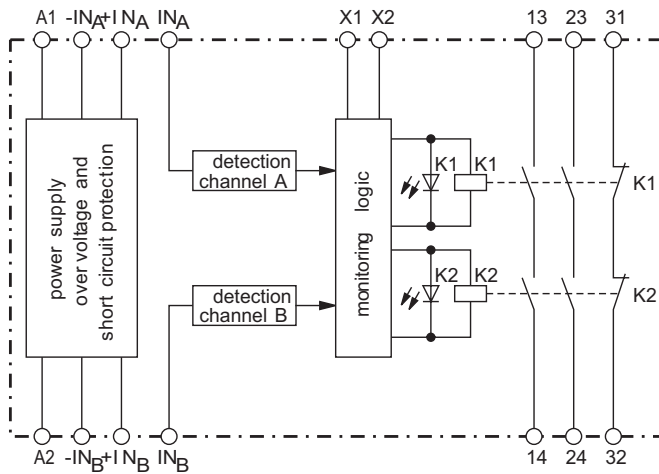

Function diagram

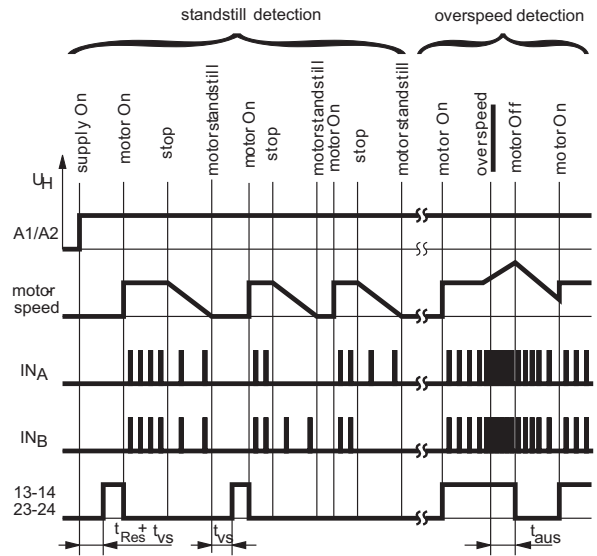

t_{Res} : reset time after connection of supply voltage
 t_{vs} : operate delay after detection of standstill/underspeed
 t_{aus} : release delay after detection of overspeed

Application

Two PNP Proximity Sensors Monitoring a 3-Phase Motor

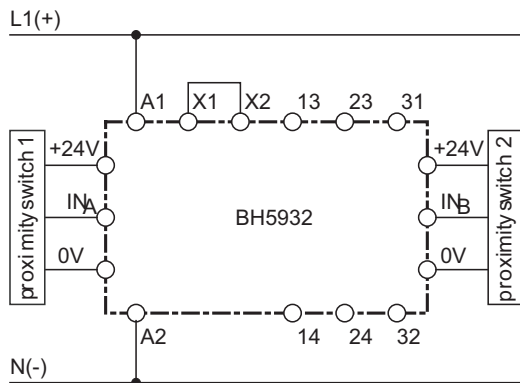

Standard connection

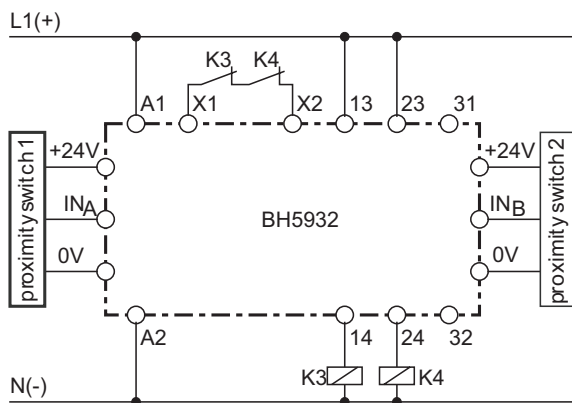

Connection with external contactors

Connection Terminals

Terminal designation	Signal designation
A1 (+)	+ / L
A2	- / N
X1, X2	Feedback circuit
+24V	+ supply for proximity sensors 1 e. g. 2
0V	- supply for proximity sensors 1 e. g. 2
INA, INB	measuring output of proximity sensors 1 e. g. 2
13, 14, 23, 24	Positive driven NO contacts for release circuit
31, 32	Positive driven NC contacts for release circuit

Safety Products



Warning: Safety products sold by AutomationDirect are Safety components only. The purchaser/installer is solely responsible for the application of these components and ensuring all necessary steps have been taken to assure each application and use meets all performance and applicable safety requirements and/or local, national and/or international safety codes as required by the application. AutomationDirect cannot certify that our products, used solely or in conjunction with other AutomationDirect or other vendors' products, will assure safety for any application. Any person using or applying any products sold by AutomationDirect is responsible for learning the safety requirements for their individual application and applying them, and therefore assumes all risks, and accepts full and complete responsibility, for the selection and suitability of the product for their respective application.

AutomationDirect does not provide design or consulting services, and cannot advise whether any specific application or use of our products would ensure compliance with the safety requirements for any application.