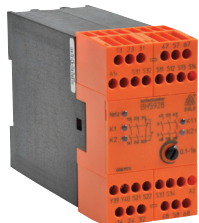

Dold BH5928 Series – 2-Channel Emergency Stop and Safety Gates with Delay

**BH5928-92-61-24-1**

Designed to protect people and machines in applications with E-stop buttons and safety gates. One or two channels can be monitored with time-delay function.

- Three time-delay options with potentiometer adjustment
- Single and 2-channel operation
- Output: 3 N.O. contacts with delay, 2 N.O. instantaneous contacts, 1 N.C. instantaneous contact
- Line fault detection for ON button, when connected to S33-S34
- Manual restart with button on S33-S34 or automatic restart with jumper between S13-S14
- Can be wired with or without cross-fault monitoring in the E-stop loop
- LED indicators for power and state of operation

Safety Relays

Part Number	Price	Marking Type	Voltage	Outputs	Time Delay
BH5928-92-61-24-1	\$298.00	2-channel E-STOP / GATE	24 VDC	3 N.O. time delay positive guided safety contacts, 2 N.O. instantaneous positive guided safety contacts and 1 N.C. instantaneous monitoring contact	0.1 to 1 second
BH5928-92-61-24-5	\$298.00	2-channel E-STOP / GATE	24 VDC		0.5 to 5 seconds
BH5928-92-61-24-30	\$298.00	2-channel E-STOP / GATE	24 VDC		3 to 30 seconds

Safety Data – Values per EN ISO 13849-1

Category	4 according to EN 954-1
Performance level	PLe according to EN 13849-1
MTTF _d	>240.5 years
DC _{avg}	99%

Safety Data – Values per IEC/EN 62061 / IEC/EN 61508

SIL CL	3 per IEC/EN 62061
SIL	3 per IEC/EN 61508
HFT (Hardware Failure Tolerance)	1
DC _{avg}	99%
SFF	99.9%
PFH _D	1.94E ⁻¹⁰ h ⁻¹

Two-Hand Controllers Safety Relay Specification Table

General Specifications	
Temperature	Storage: -25°C to 85°C (-13°F to 185°F) Operating: -15°C to 55°C (5°F to 131°F)
Altitude	< 2,000 meters
Vibration Resistance	Amplitude: 0.35mm, Frequency: 10 to 55 Hz (IEC/EN 60-068-2-6)
Degree of Protection	Per IEC/EN 60 529. Housing: IP40; Terminals IP20
Housing	UL 94V-0 Thermoplastic; Din mount 35 mm x 7.5 mm
Weight	400 g (14.11 oz.)
Agency Approvals and Standards	cULus file E107778, CE, RoHS
Terminal Designation per EN 50 005 Wire Connections	1x4 mm ² solid or 1 x 2.5 mm ² stranded ferruled (isolated) or 2 x 1.5 mm ² stranded ferruled (isolated) DIN 46 228-1/-2/-3/-4 or 2 x 2.5 mm ² stranded ferruled DIN 46 228-1/-2/-3
Wire Fixing	Box terminal with wire protection
Input Specifications	
Nominal Voltage	24VDC
Voltage Range	At 10% residual ripple: DC: 0.9 to 1.1 UN At 48% residual ripple: DC: 0.8 to 1.1 UN
Maximum Consumption	DC approx. 3.5W
Minimum Off-time	1.0 second
Short Circuit Protection	Internal with PTC (Positive Temperature Coefficient resistor)
Overvoltage Protection	Internal VDR (Voltage Dependent Resistor)
Output Specifications	
Electrical Contact Life	To DC 13 at 2A, DC 24V: >1.5 x 10 ⁵ switching cycles To AC 15 at 2A, 230VAC: 10 ⁵ switching cycles IEC/EN 60 947-5-1
Mechanical Life	10 x 10 ⁶ switching cycles
Contact Type	2 N.O. positively driven and 1 N.C. relay contacts, and 3 N.O. positively driven relay contacts with delay. (N.O. contacts are safety contacts)
Operate Delay	Operate delay typ at UN: manual start: 40 ms; automatic start: 500 ms
Release Delay	Release delay typ at UN: Disconnecting supply: 40 ms; Disconnecting S12, S22, S31 and S32: 15ms
Repeat Accuracy	±1% of setting value
Nominal Output Voltage	AC: 250V; DC: See continuous current limit curve in manual.
Thermal Current (I _{th})	Max. 5A, See continuous current limit curve in manual.
Switching of Low Loads	M100 mV; (contacts with 5μ Au) M 1 mA
Short Circuit Strength	Max. fuse rating: 6 A gL (IEC/EN 60 947-5-1); Line circuit breaker C 8 A
Switching Capacity	AC 15: N.O. contacts: 3A/230V; N.C. contacts: 2A/230VAC; DC 13: N.O. contacts: 5A/24VDC; ON: 0.4s, OFF: 9.6 s
Switching Frequency	Max. 1200 switching cycles/hr, with manual restart and short release delay time
Indicator Contact	DC 13: N.C. contact: 2A/24VDC

Dold BH5928 Series – 2-Channel Emergency Stop and Safety Gates with Delay



Wiring

BH5928 Block Diagram

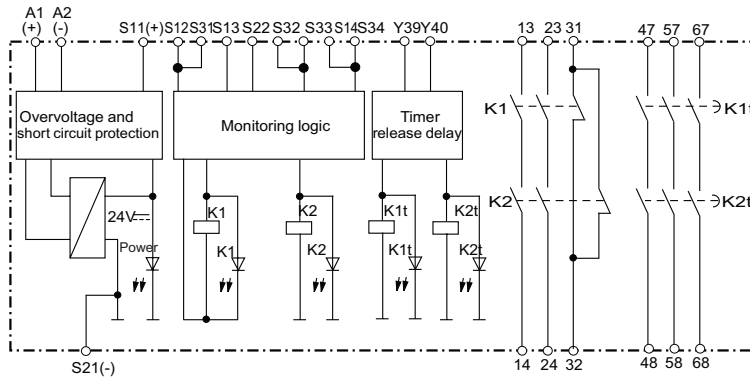

Dimensions

mm [in]

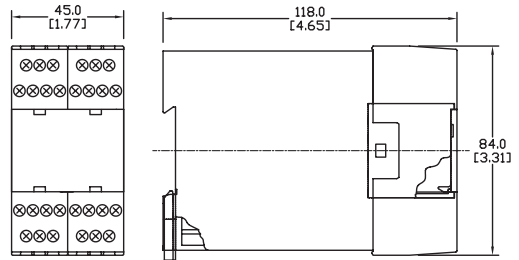

Applications

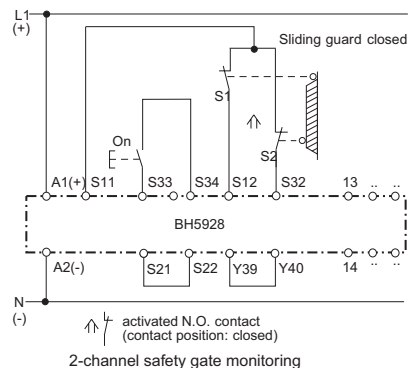
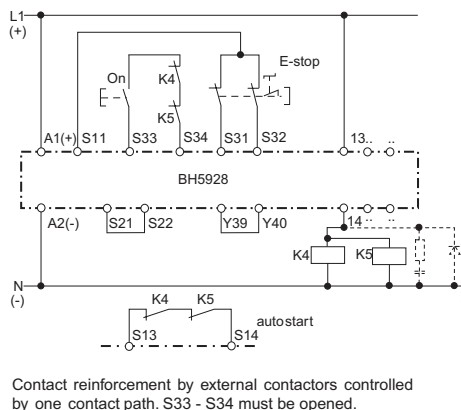
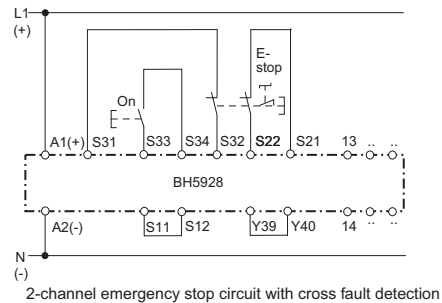
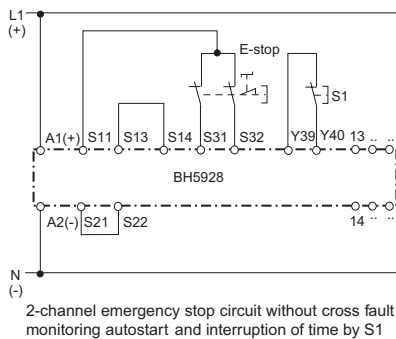
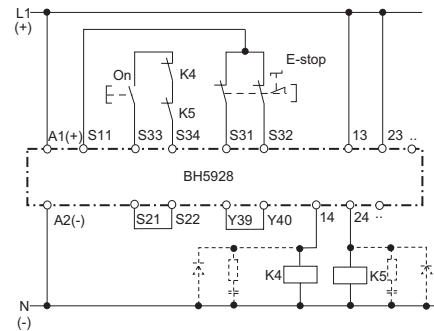
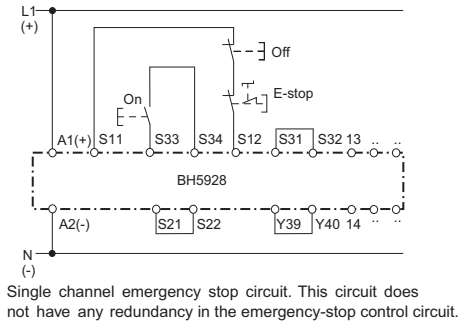

*Note: When switching inductive loads, surge suppressors are recommended.

Dold LG5929 Extension Module



Additional contacts for emergency-stop modules and safety gate monitors.

- 1-channel or 2-channel connection
- LED indication for operation
- Output: 5 N.O. and 1 N.C. contacts

Safety Data – Values per EN ISO 13849-1

Category	4 according to EN 954-1
Performance level	PLe according to EN 13849-1
MTTF_d	>100 years
DC_{avg}	99%

Safety Data – Values per IEC/EN 62061 /IEC/EN 61508

SIL CL	3 per IEC/EN 62061
SIL	3 per IEC/EN 61508
HFT (Hardware Failure Tolerance)	1
DC_{avg}	99%
SFF	99.7%
PFH_D	4.68E ⁻¹⁰ h ⁻¹

Safety Relays Selection Chart

Part Number	Price	Marking Type	Voltage	Outputs
LG5929-60-100-61	\$136.00	Safety relay extension module	24 VAC/VDC	5 N.O./1 N.C.

Safety Relay Extension Module Specification Table

General Specifications	
Temperature	Storage: -25°C to 85°C (-13°F to 185°F) Operating: -15°C to 55°C (5°F to 131°F)
Altitude	< 2,000 meters
Vibration Resistance	Amplitude: 0.35mm, Frequency: 10 to 55 Hz (IEC/EN 60-068-2-6)
Degree of Protection	Per IEC/EN 60 529. Housing: IP40; Terminals IP20
Housing	UL 94V-0 Thermoplastic; Din mount 35 mm x 7.5 mm
Weight	205g (7.23 oz.)
Agency Approvals and Standards	CSA, cULus file E107778, CE, RoHS, TUV
Terminal Designation per EN 50 005 Wire Connections	1x4 mm ² solid or 1 x 2.5 mm ² stranded ferruled (isolated) or 2 x 1.5 mm ² stranded ferruled (isolated) DIN 46 228-1/-2/-3/-4 or 2 x 2.5 mm ² solid per DIN 46 228-1/-2/-3 /-4
Wire Fixing	Plus-minus terminal screws M3.5 box terminals with wire protection or cage clamp terminals.
Input Specifications	
Nominal Voltage	24V AC/DC
Voltage Range	AC: 0.85 to 1.1 U _N At 10% residual ripple: 0.9 to 1.1 U _N ; At 48% residual ripple: 0.85 to 1.1 U _N
Maximum Consumption	24VAC/DC: 1.8VA
Nominal Frequency	50 to 60 Hz
Control Current	Control current typ. at 24V over 2 relays: 75 mA
Overvoltage Protection	Internal VDR (Voltage Dependent Resistor)
Output Specifications	
Electrical Contact Life	To AC15 at 2 A,230V: 10 ⁵ switching cycles IEC/EN 60 947-5-1
Mechanical Life	20 x 10 ⁶ switching cycles
Contact Type	5 N.O. positively driven and 1 N.C. relay contacts (N.O. contacts are safety contacts)
Operate/Release Time	Operate typ at U _N : 20 ms.; Release typ at U _N : 35 ms.
Nominal Output Voltage	250VAC
Thermal Current (I_{th})	Max. 5A per contact. See continuous current limit curve in installation manual.
Short Circuit Strength	Max fuse rating:10A gl (IEC/EN 60 9470-5-1); Line circuit breaker: B6A
Switching Capacity IEC/EN 60 947-5-1	AC 15: N.O. contacts: 3A/230V; N.C. contacts: 2A/230VAC DC 13: N.O. contacts: 4A/24V; N.C. contacts: 4A/24VDC; N.O. contact: 8A/24V >25x10 ³ ON: 0.4s, OFF: 9.6s
Switching Frequency	Max. 1,200 switching cycles/hr

Dold LG5929 Extension Module



Wiring

Dimensions mm [in]

LG5929 Block Diagram

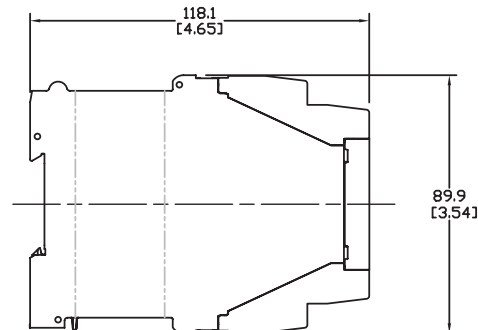
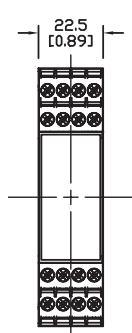
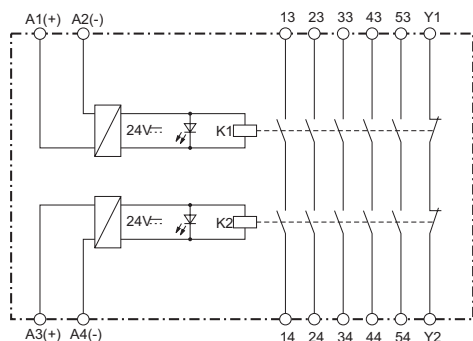

Applications

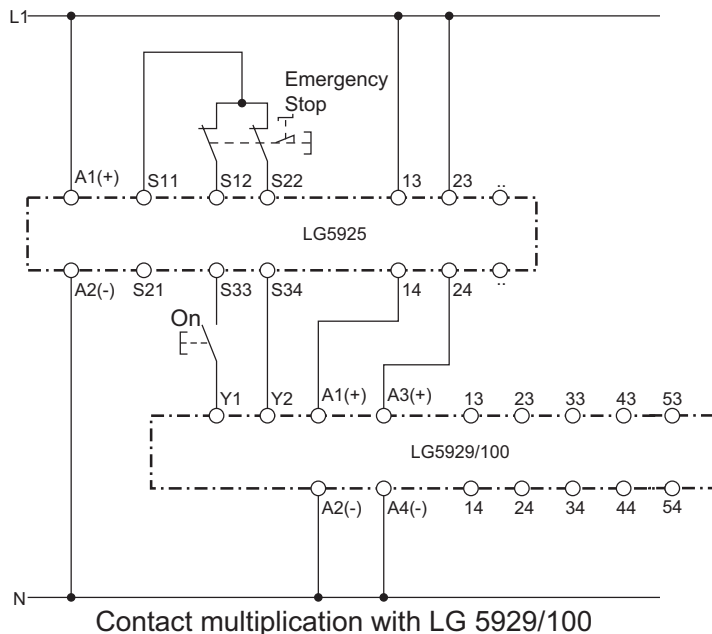

Note: This is a representative drawing. Depending on the LG5925 safety relay you select, different voltage sources may be required.

**Note: When switching inductive loads, surge suppressors are recommended.*

Safety Products



Warning: Safety products sold by AutomationDirect are Safety components only. The purchaser/installer is solely responsible for the application of these components and ensuring all necessary steps have been taken to assure each application and use meets all performance and applicable safety requirements and/or local, national and/or international safety codes as required by the application. AutomationDirect cannot certify that our products, used solely or in conjunction with other AutomationDirect or other vendors' products, will assure safety for any application. Any person using or applying any products sold by AutomationDirect is responsible for learning the safety requirements for their individual application and applying them, and therefore assumes all risks, and accepts full and complete responsibility, for the selection and suitability of the product for their respective application.

AutomationDirect does not provide design or consulting services, and cannot advise whether any specific application or use of our products would ensure compliance with the safety requirements for any application.