

# Dold LG5925 Series 2-Channel Emergency Stop and Safety Gates



LG5925-48-61-24

Designed to protect people and machines in applications with E-stop buttons and safety gates.

- Outputs: 3 NO contacts and 1 NC contact
- Feedback circuit to monitor external contactors used for reinforcement of contacts
- Overvoltage and short-circuit protection
- Monitored manual restart
- Single and 2-channel operation
- LED indicators for power and state of operation

## Safety Data – Values per EN ISO 13849-1

<b>Category</b>	4 according to EN 954-1
<b>Performance level</b>	PLe according to EN 13849-1
<b>MTTF<sub>d</sub></b>	>100 years
<b>DC<sub>avg</sub></b>	99%

## Safety Data – Values per IEC/EN 62061 / IEC/EN 61508

<b>SIL CL</b>	3 per IEC/EN 62061
<b>SIL</b>	3 per IEC/EN 61508
<b>HFT (Hardware Failure Tolerance)</b>	1
<b>DC<sub>avg</sub></b>	99%
<b>SFF</b>	99.7%
<b>PFH<sub>D</sub></b>	2.66E <sup>-10</sup> h <sup>-1</sup>

## Safety Relays Selection Chart

Part Number	Price	Marking Type	Voltage	Outputs	Connection	Drawing
<a href="#">LG5925-48-61-24</a>	\$165.00	2-channel E-STOP/GATE	24 VAC/DC	3 NO 1 NC	Fixed screw terminal	<a href="#">PDF</a>
<a href="#">LG5925-48PC-61-24</a>	\$175.00				Push-in cage clamp	<a href="#">PDF</a>
<a href="#">LG5925-48-61-110</a>	\$180.00		110VAC		Fixed screw terminal	<a href="#">PDF</a>
<a href="#">LG5925-48PC-61-110</a>	\$190.00				Push-in cage clamp	<a href="#">PDF</a>
<a href="#">LG5925-48-61-230</a>	\$180.00		230VAC		Fixed screw terminal	<a href="#">PDF</a>

## LG5925 Controllers Safety Relay Specification Table

General Specifications	
<b>Temperature</b>	Storage: -40°C to 85°C [-40°F to 185°F]; Operating: -25°C to 60°C [-13°F to 140°F]
<b>Altitude</b>	< 2,000m [6562ft]
<b>Vibration Resistance</b>	Amplitude: 0.35 mm, Frequency: 10 to 55 Hz (IEC/EN 60-068-2-6)
<b>Degree of Protection</b>	Per IEC/EN 60 529. Housing: IP40; Terminals IP20
<b>Housing</b>	UL 94V-0 Thermoplastic; DIN mount 35mm x 7.5 mm
<b>Weight</b>	LG5925 24V AC/DC: 210g [7.40 oz]; LG5925 110V, 230V AC: 275g [9.70 oz]
<b>Agency Approvals and Standards</b>	CSA, cULus file E107778, CE, RoHS, TUV
<b>Terminal Designation per EN 50 005 Wire Connections</b>	1x4 mm <sup>2</sup> solid or 1 x 2.5 mm <sup>2</sup> stranded ferruled (isolated) or 2 x 1.5 mm <sup>2</sup> stranded ferruled (isolated) DIN 46 228-1/-2/-3/-4 or 2 x 2.5 mm <sup>2</sup> solid DIN 46 228-1/-2/-3/-4
<b>Wire Fixing</b>	Terminal screws M3.5 box terminals with wire protection or cage clamp terminals.
Input Specifications	
<b>Nominal Voltage</b>	110VAC, 230VAC, 24VAC/DC
<b>Voltage Range</b>	At 10% residual ripple: AC/DC: 0.9 to 1.1 UN; AC: 0.85 to 1.1 UN
<b>Maximum Consumption</b>	DC approx. 1.7 W; AC approx. 3.7 VA
<b>Minimum Off-time</b>	250ms
<b>Control Voltage on S11 At UN</b>	AC/DC units: 22VDC; AC units: 24VDC
<b>Control Current Typ. Over S12, S22</b>	30mA at UN
<b>Min. Voltage on S12, S22 (relay activated)</b>	AC/DC units: 20VDC; AC units: 19VDC
<b>Short Circuit Protection</b>	Internal with PTC (Positive Temperature Coefficient resistor)
<b>Overvoltage Protection</b>	Internal VDR (Voltage Dependent Resistor)
Output Specifications	
<b>Electrical Contact Life</b>	AC 15 at 5A, 230VAC: > 2.2x10 <sup>5</sup> switching cycles
<b>Mechanical Life</b>	> 20x10 <sup>6</sup> switching cycles
<b>Contact Type</b>	3 positively driven NO and 1 NC relay contacts (NO contacts are safety contacts)
<b>Operate Delay</b>	Manual start: 30ms; automatic start: 350ms
<b>Release Delay</b>	Disconnecting the supply: AC units: 150ms; DC units: 50ms Disconnecting S12, S22: AC units: 130ms. DC units: 50ms
<b>Nominal Output Voltage</b>	AC: 250V; DC: See continuous current limit curve in installation manual.
<b>Thermal Current (I<sub>th</sub>)</b>	Max. 8A. See continuous current limit curve in installation manual.
<b>Short Circuit Strength</b>	Max. fuse rating: 10A gL (IEC/EN 60 947-5-1); Line circuit breaker: B 6A
<b>Switching Capacity (IEC/EN 60 947-5-1)</b>	AC 15: NO contacts: 3A/230V; NC contacts: 2A/230V DC 13: N.O. contacts: 4A/DC24V. 0.5A/110V; NC. contacts: 4A/24V; DC 13: N.O. contacts: 8A/24V >25x103. ON: 0.4 s, OFF: 9.6 s
<b>Switching Frequency</b>	Max. 1200 switching cycles/hr

# Dold LG5925 Series 2-Channel Emergency Stop and Safety Gates



## Wiring LG5925 Block Diagram

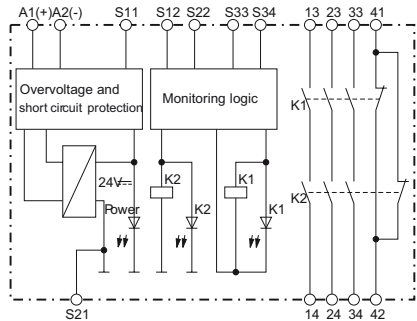

## Applications

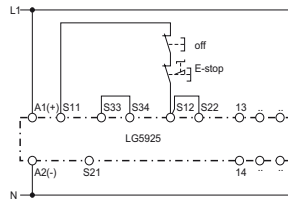

Single channel emergency stop circuit. This circuit does not have any redundancy in the emergency-stop control circuit.  
 Note: Refer to "Unit programming"  
 Set switch or dip switch in pos.: S1 no cross fault detection  
 S2 automatic start

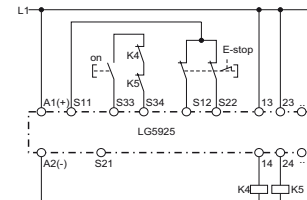

Contact reinforcement by external contactors, 2-channel controlled. The output contacts can be reinforced by external contactors with positive guided contacts for switching currents > 8 A. Functioning of the external contactors is monitored by looping the N.C. contacts into the closing circuit (terminals S33-S34).  
 Note: Refer to "Unit programming"  
 Set switch or dip switch in pos.: S1 no cross fault detection  
 S2 manual start

## S1 and S2 Switch Setting Instructions

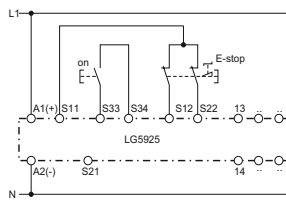
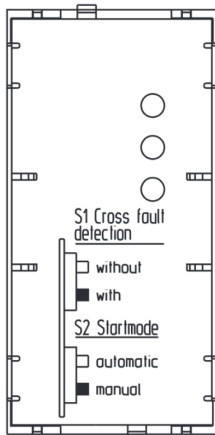
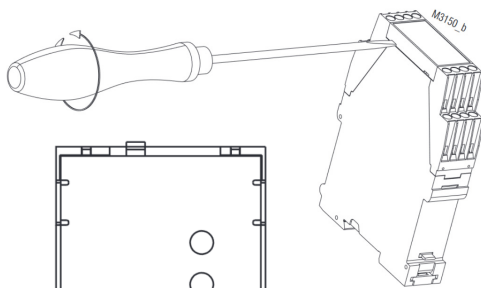

2-channel emergency stop circuit without cross fault monitoring.  
 Note: Refer to "Unit programming"  
 Set switch or dip switch in pos.: S1 no cross fault detection  
 S2 manual start

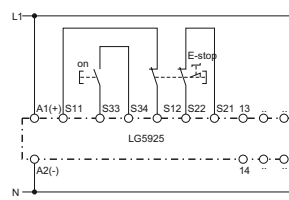

2-channel emergency stop circuit with cross fault detection.  
 Note: Refer to "Unit programming"  
 Set switch or dip switch in pos.: S1 cross fault detection  
 S2 manual start

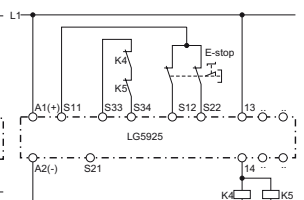

Contact reinforcement by external contactors controlled by one contact path.  
 Note: Refer to "Unit programming"  
 Set switch or dip switch in pos.: S1 no cross fault detection  
 S2 automatic start

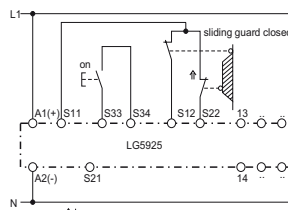

2-channel safety gate monitoring.  
 Note: Refer to "Unit programming"  
 Set switch or dip switch in pos.: S1 no cross fault detection  
 S2 manual start

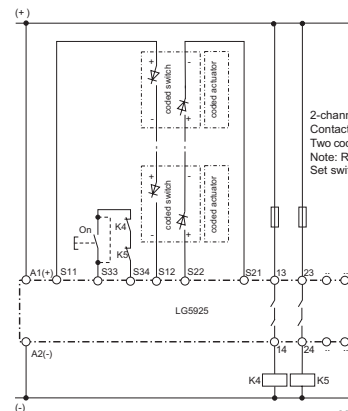

2-channel emergency stop circuit with cross fault. Contact reinforcement by external contactors. Two coded non-contact sensors in series.  
 Note: Refer to "Unit programming"  
 Set switch or dip switch in pos.: S1 cross fault detection  
 S2 Manual or Automatic (dotted jumper)

**Note: When switching inductive loads, surge suppressors are recommended.**

Disconnect unit before setting switches.

Drawing shows settings as delivered to the customer.

# Dold LG5929 Extension Module



Additional contacts for emergency-stop modules and safety gate monitors.

- 1-channel or 2-channel connection
- LED indication for operation
- Output: 5 N.O. and 1 N.C. contacts

## Safety Data – Values per EN ISO 13849-1

<b>Category</b>	<b>4 according to EN 954-1</b>
<b>Performance level</b>	PLe according to EN 13849-1
<b>MTTF<sub>d</sub></b>	>100 years
<b>DC<sub>avg</sub></b>	99%

## Safety Data – Values per IEC/EN 62061 /IEC/EN 61508

<b>SIL CL</b>	3 per IEC/EN 62061
<b>SIL</b>	3 per IEC/EN 61508
<b>HFT (Hardware Failure Tolerance)</b>	1
<b>DC<sub>avg</sub></b>	99%
<b>SFF</b>	99.7%
<b>PFH<sub>D</sub></b>	4.68E <sup>-10</sup> h <sup>-1</sup>

## Safety Relays Selection Chart

Part Number	Price	Marking Type	Voltage	Outputs
<b>LG5929-60-100-61</b>	\$136.00	Safety relay extension module	24 VAC/VDC	5 N.O./1 N.C.

## Safety Relay Extension Module Specification Table

General Specifications	
<b>Temperature</b>	Storage: -25°C to 85°C (-13°F to 185°F) Operating: -15°C to 55°C (5°F to 131°F)
<b>Altitude</b>	< 2,000 meters
<b>Vibration Resistance</b>	Amplitude: 0.35mm, Frequency: 10 to 55 Hz (IEC/EN 60-068-2-6)
<b>Degree of Protection</b>	Per IEC/EN 60 529. Housing: IP40; Terminals IP20
<b>Housing</b>	UL 94V-0 Thermoplastic; Din mount 35 mm x 7.5 mm
<b>Weight</b>	205g (7.23 oz.)
<b>Agency Approvals and Standards</b>	CSA, cULus file E107778, CE, RoHS, TUV
<b>Terminal Designation per EN 50 005 Wire Connections</b>	1x4 mm <sup>2</sup> solid or 1 x 2.5 mm <sup>2</sup> stranded ferruled (isolated) or 2 x 1.5 mm <sup>2</sup> stranded ferruled (isolated) DIN 46 228-1/-2/-3/-4 or 2 x 2.5 mm <sup>2</sup> solid per DIN 46 228-1/-2/-3 /-4
<b>Wire Fixing</b>	Plus-minus terminal screws M3.5 box terminals with wire protection or cage clamp terminals.
Input Specifications	
<b>Nominal Voltage</b>	24V AC/DC
<b>Voltage Range</b>	AC: 0.85 to 1.1 U <sub>N</sub> At 10% residual ripple: 0.9 to 1.1 U <sub>N</sub> ; At 48% residual ripple: 0.85 to 1.1 U <sub>N</sub>
<b>Maximum Consumption</b>	24VAC/DC: 1.8VA
<b>Nominal Frequency</b>	50 to 60 Hz
<b>Control Current</b>	Control current typ. at 24V over 2 relays: 75 mA
<b>Overvoltage Protection</b>	Internal VDR (Voltage Dependent Resistor)
Output Specifications	
<b>Electrical Contact Life</b>	To AC15 at 2 A,230V: 10 <sup>5</sup> switching cycles IEC/EN 60 947-5-1
<b>Mechanical Life</b>	20 x 10 <sup>6</sup> switching cycles
<b>Contact Type</b>	5 N.O. positively driven and 1 N.C. relay contacts (N.O. contacts are safety contacts)
<b>Operate/Release Time</b>	Operate typ at U <sub>N</sub> : 20 ms.; Release typ at U <sub>N</sub> : 35 ms.
<b>Nominal Output Voltage</b>	250VAC
<b>Thermal Current (I<sub>th</sub>)</b>	Max. 5A per contact. See continuous current limit curve in installation manual.
<b>Short Circuit Strength</b>	Max fuse rating:10A gl (IEC/EN 60 9470-5-1); Line circuit breaker: B6A
<b>Switching Capacity IEC/EN 60 947-5-1</b>	AC 15: N.O. contacts: 3A/230V; N.C. contacts: 2A/230VAC DC 13: N.O. contacts: 4A/24V; N.C. contacts: 4A/24VDC; N.O. contact: 8A/24V >25x10 <sup>3</sup> ON: 0.4s, OFF: 9.6s
<b>Switching Frequency</b>	Max. 1,200 switching cycles/hr

# Dold LG5929 Extension Module



## Wiring

## Dimensions mm [in]

**LG5929 Block Diagram**

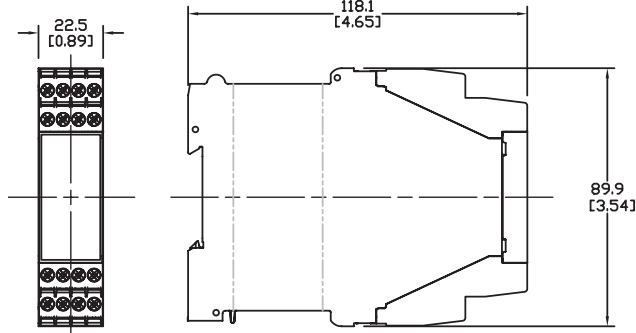
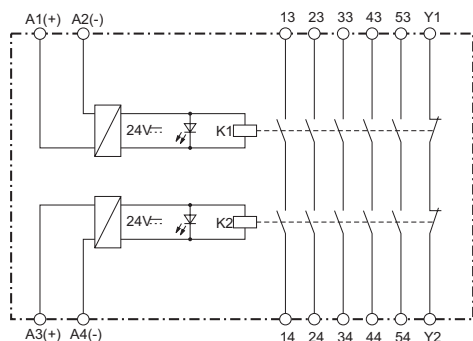

## Applications

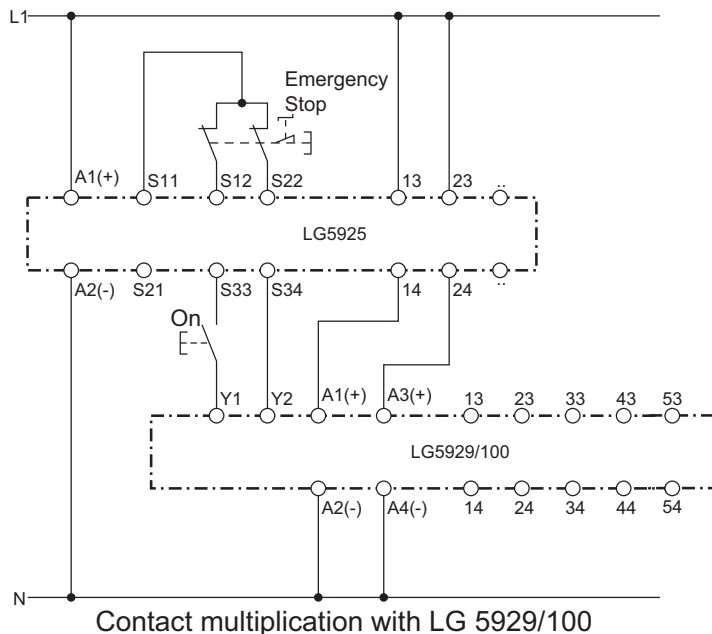

*Note: This is a representative drawing. Depending on the LG5925 safety relay you select, different voltage sources may be required.*

*\*Note: When switching inductive loads, surge suppressors are recommended.*

# Safety Products



*Warning: Safety products sold by AutomationDirect are Safety components only. The purchaser/installer is solely responsible for the application of these components and ensuring all necessary steps have been taken to assure each application and use meets all performance and applicable safety requirements and/or local, national and/or international safety codes as required by the application. AutomationDirect cannot certify that our products, used solely or in conjunction with other AutomationDirect or other vendors' products, will assure safety for any application. Any person using or applying any products sold by AutomationDirect is responsible for learning the safety requirements for their individual application and applying them, and therefore assumes all risks, and accepts full and complete responsibility, for the selection and suitability of the product for their respective application.*

*AutomationDirect does not provide design or consulting services, and cannot advise whether any specific application or use of our products would ensure compliance with the safety requirements for any application.*