

GS/DURAPULSE Accessories – RF Filter

RF Filter for GS1,GS2,GS3/DURAPULSE AC Drives		
Part Number	Price	Drive Model
RF220X00A	\$26.50	GS1-xxxx GS2-xxxx GS3-xxxx

Description

Zero phase reactors, (aka RF noise filters) help reduce radiated noise from the inverter wiring. The wiring must go through the opening to reduce the RF component of the electrical noise. Loop the wires three times (four turns) to attain the full RF filtering effect. For larger wire sizes, place multiple zero-phase reactors (up to four) side by side for a greater filtering effect. These are effective for noise reduction on both the input and output sides of the inverter. Attenuation quality is good in a wide range from AM band to 10 Mhz.

Wiring Method

Wind each wire four times around the core, as shown in diagram A to the right. The reactor must be put at inverter side as closely as possible.

If you are unable to wire as above due to wire size or another aspect of your application, put all wires through four cores in series without winding, as in diagram B to the right.

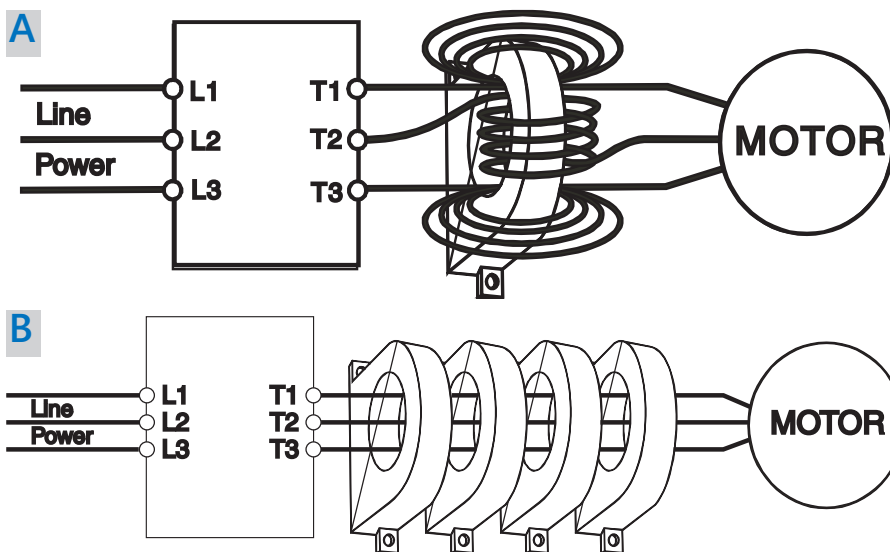
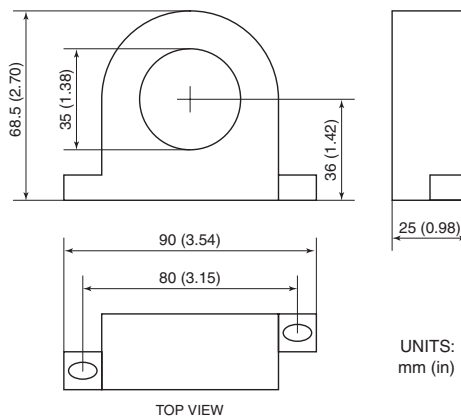
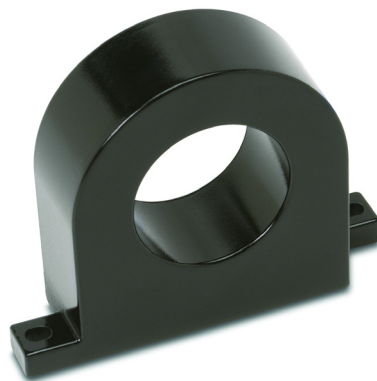

AC Drives Optional Accessories – Overview

Drive Accessories
(not all accessories are applicable for every drive model)

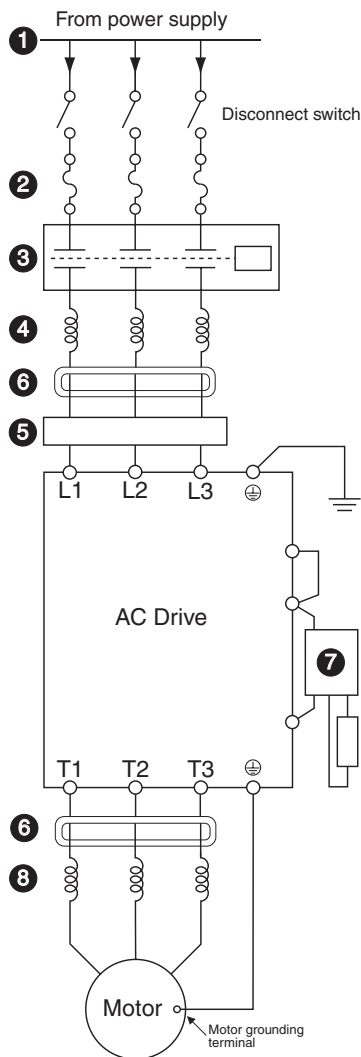

1 Power Supply

Please follow the specific power supply requirements as detailed in the specific drive manual.

2 Fuses

Input fuses protect the AC drive from excessive input current due to line surges, short circuits, and ground faults. They are recommended for all installations and may be required for UL-listed installations.

3 Contactor (Optional)

Do not use a contactor or disconnect switch for run/stop control of the AC drive and motor. This will reduce the operating life cycle of the AC drive. Cycling a power circuit switching device while the AC drive is in run mode should be done only in emergency situations.

4 Input Line Reactor (Optional)

See the Line Reactors section at www.automationdirect.com for more information.

Input line reactors protect the AC drive from transient overvoltage conditions, typically caused by utility capacitor switching. The input line reactor also reduces the harmonics associated with AC drives. Input line reactors are recommended for all installations.

5 EMI filter (Optional)

See the EMI Filters section at www.automationdirect.com for more information.

Input EMI filters reduce electromagnetic interference or noise on the input side of the AC drive. They are required for CE compliance and recommended for installations prone to or sensitive to electromagnetic interference.

6 RF filter (Optional)

RF filters reduce the radio frequency interference or noise on the input or output side of the inverter.

7 Braking Unit and/or Braking Resistor (Optional)

Dynamic braking allows the AC drive to produce additional braking (stopping) torque. AC drives can typically produce between 15% & 20% braking torque without the addition of any external components. The addition of optional braking may be required for applications that require rapid deceleration or high inertia loads.

8 Output Load Reactor or Voltage Time (dV/dT) Filter (Optional)

Output line reactors protect the motor insulation against AC drive short circuits and IGBT reflective wave damage, and also "smooth" the motor current waveform, allowing the motor to run cooler. They are **recommended for operating "noninverter-duty" motors and when the length of wiring between the AC drive and motor is less than 100 feet.**

Voltage Time filters provide enhanced protection for motors with distances up to 1,000 feet.

Voltage Time filters provide even more protection against wave reflection and reduce common mode noise. They are recommended when the length of wiring between the AC drive and motor is from 100 feet up to 1,000 feet.

See www.automationdirect.com for specific product offerings.