

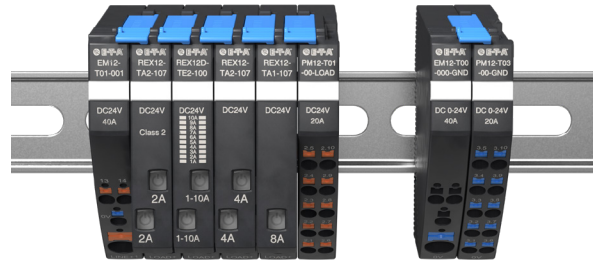

# REX Series Modular Circuit Protectors

## Features

- Modular design using power supply, overcurrent protection, and power distribution modules
- No tools required for assembly
- Circuit protection via electronic trip curve
- Slim 12.5 mm module width
- 1 to 10A fixed and adjustable operating current
- Integral fail-safe element, adjusted to max. current rating
- Circuit protection rated for capacitive loads up to 20,000  $\mu$ F
- Manual ON/OFF/reset switch
- LED status indication with auxiliary contact output
- Push-in terminal connections with release buttons



## REX Series Modular Circuit Protectors Selection Chart

Part Number	Price	Module Type	Number of Channels	Operating Current	Voltage Rating	Operating Voltage	Input Voltage	Output Voltage	Weight g [oz]	Drawing Link	Agency Approvals
<b>Entrance Modules</b>											
<a href="#"><u>EM-T01-001-24-40A</u></a> *	\$25.50	Mains supply	—	40A	24VDC	24VDC	24VDC	—	52 [1.83]	<a href="#"><u>PDF</u></a>	CE, UL Recognized E320024
<a href="#"><u>EM-T00-000-GND-40A</u></a>	\$11.00	Ground supply 0V	—	40A		0VDC	0VDC	—	40 [1.41]	<a href="#"><u>PDF</u></a>	CE, UL Recognized E335289
<b>Potential Modules</b>											
<a href="#"><u>PM-T01-00-LOAD-20A</u></a>	\$29.50	Load distribution	8	20A	24VDC	24VDC	24VDC	24VDC	52 [1.83]	<a href="#"><u>PDF</u></a>	CE, UL Recognized E335289
<a href="#"><u>PM-T03-00-GND-20A</u></a>	\$27.00	Ground distribution	8	20A		0VDC	0VDC	0VDC	52 [1.83]	<a href="#"><u>PDF</u></a>	
<b>Circuit Protector Modules</b>											
<a href="#"><u>REXD-TE2-24-1A-10A</u></a>	\$53.50	Overcurrent protection	2 independent	adjustable 1-10A	24VDC	—	—	24VDC	62 [2.18]	<a href="#"><u>PDF</u></a>	CE, UL Recognized E320024, UL Listed E492388
<a href="#"><u>REX-TA1-24-10A</u></a>	\$41.00		1	10A		—	—		57 [2.01]	<a href="#"><u>PDF</u></a>	
<a href="#"><u>REX-TA1-24-8A</u></a>	\$41.00		1	8A		—	—		57 [2.01]	<a href="#"><u>PDF</u></a>	
<a href="#"><u>REX-TA2-24-6A</u></a>	\$45.50		2 independent	6A		—	—		58 [2.04]	<a href="#"><u>PDF</u></a>	
<a href="#"><u>REX-TA2-24-4A</u></a>	\$45.50		2 independent	4A		—	—		58 [2.04]	<a href="#"><u>PDF</u></a>	
<a href="#"><u>REX-TA2-24-3A-N</u></a>	\$57.00		2 independent	3A		—	—		58 [2.04]	<a href="#"><u>PDF</u></a>	
<a href="#"><u>REX-TA2-24-2A</u></a>	\$45.50		2 independent	2A		—	—		58 [2.04]	<a href="#"><u>PDF</u></a>	

\* 1 EM-T01-001-24-40A is required for each system.  
Maximum 16 modules or 40A max per system.



# REX Series Modular Circuit Protectors

## Application Example

Application example: EM-T ... with REX-TAx... and PM-T...

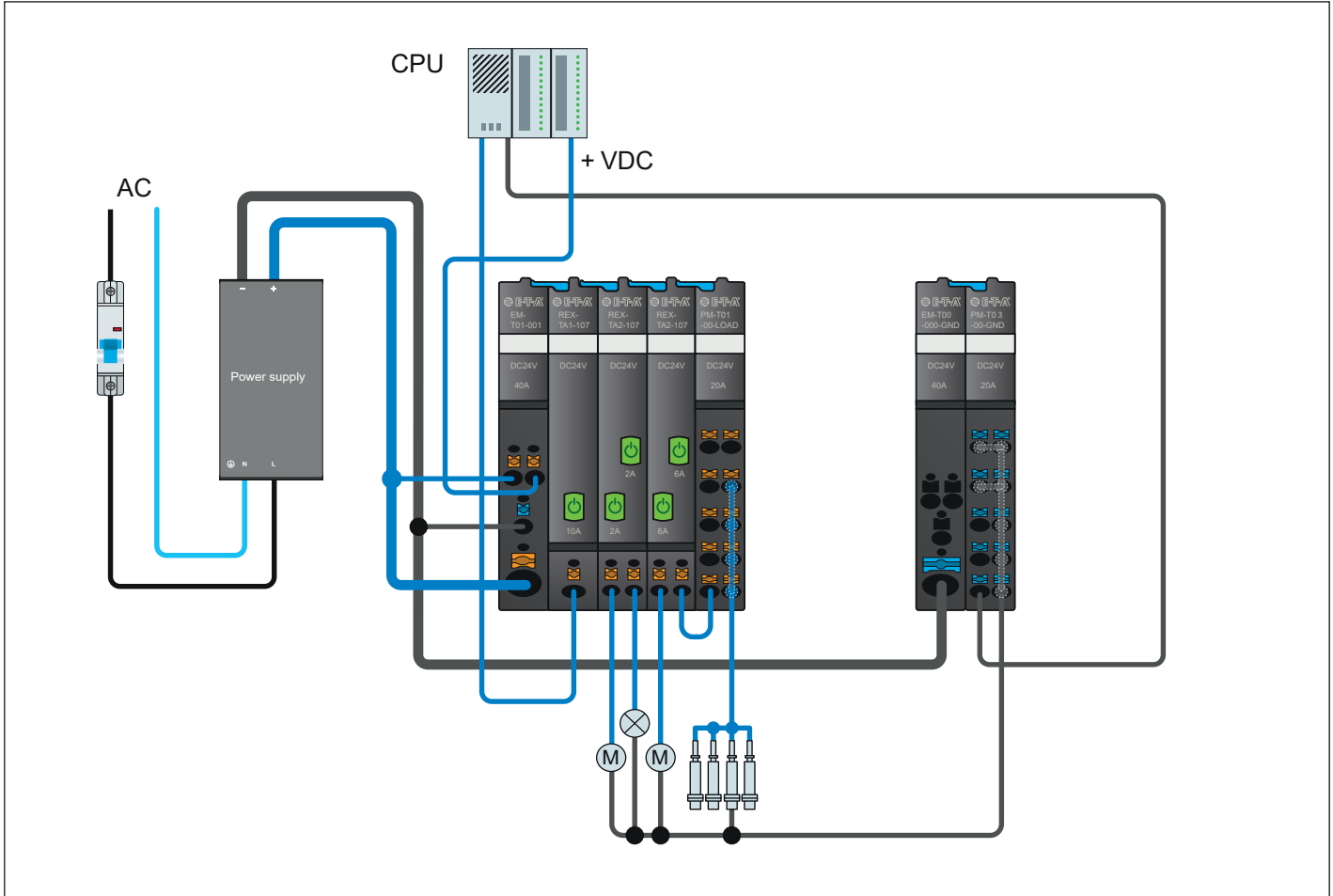



# REX Series Modular Circuit Protectors

## REX Series Basic Architecture

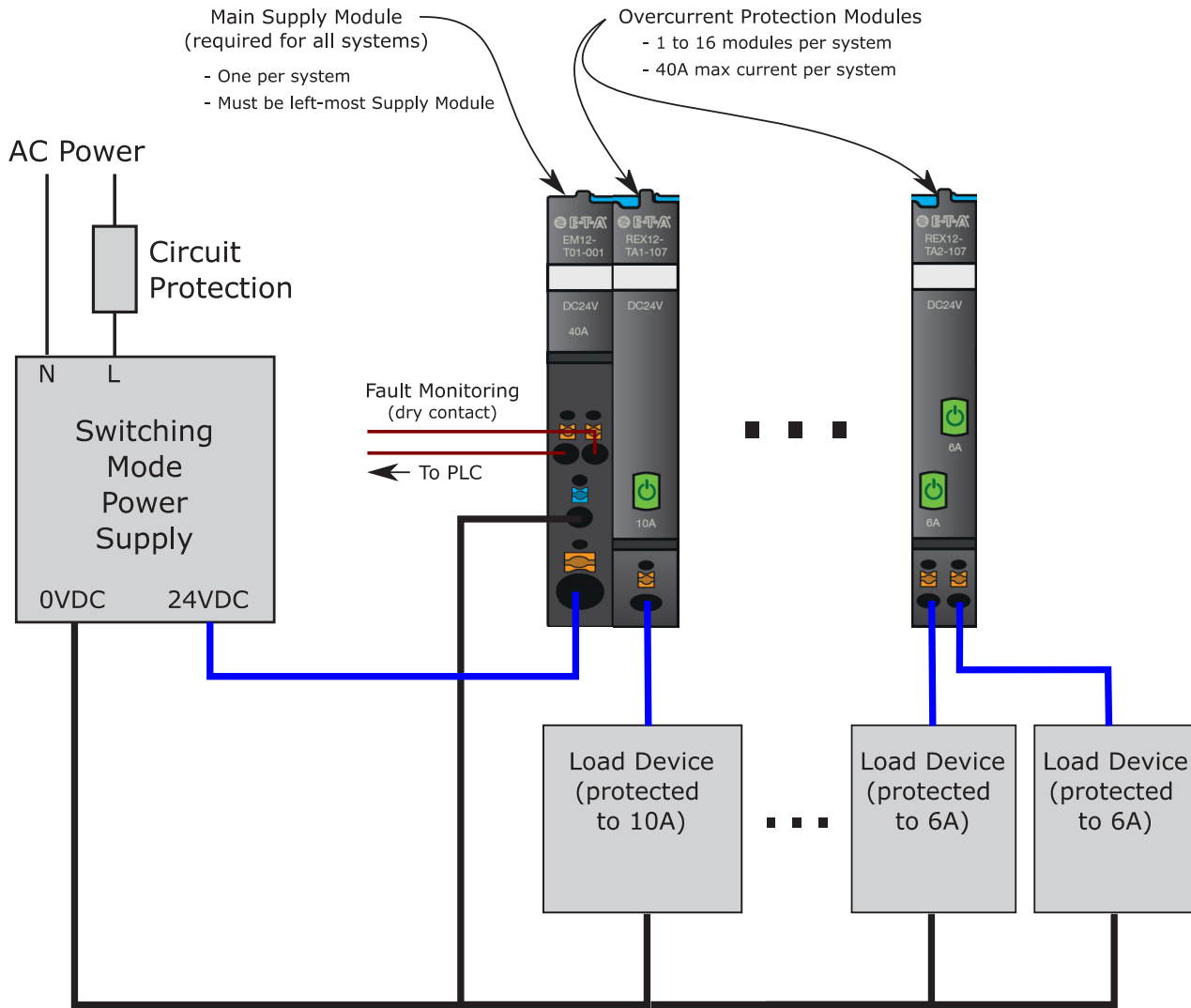



# REX Series Modular Circuit Protectors

## REX Series Full-Featured Architecture

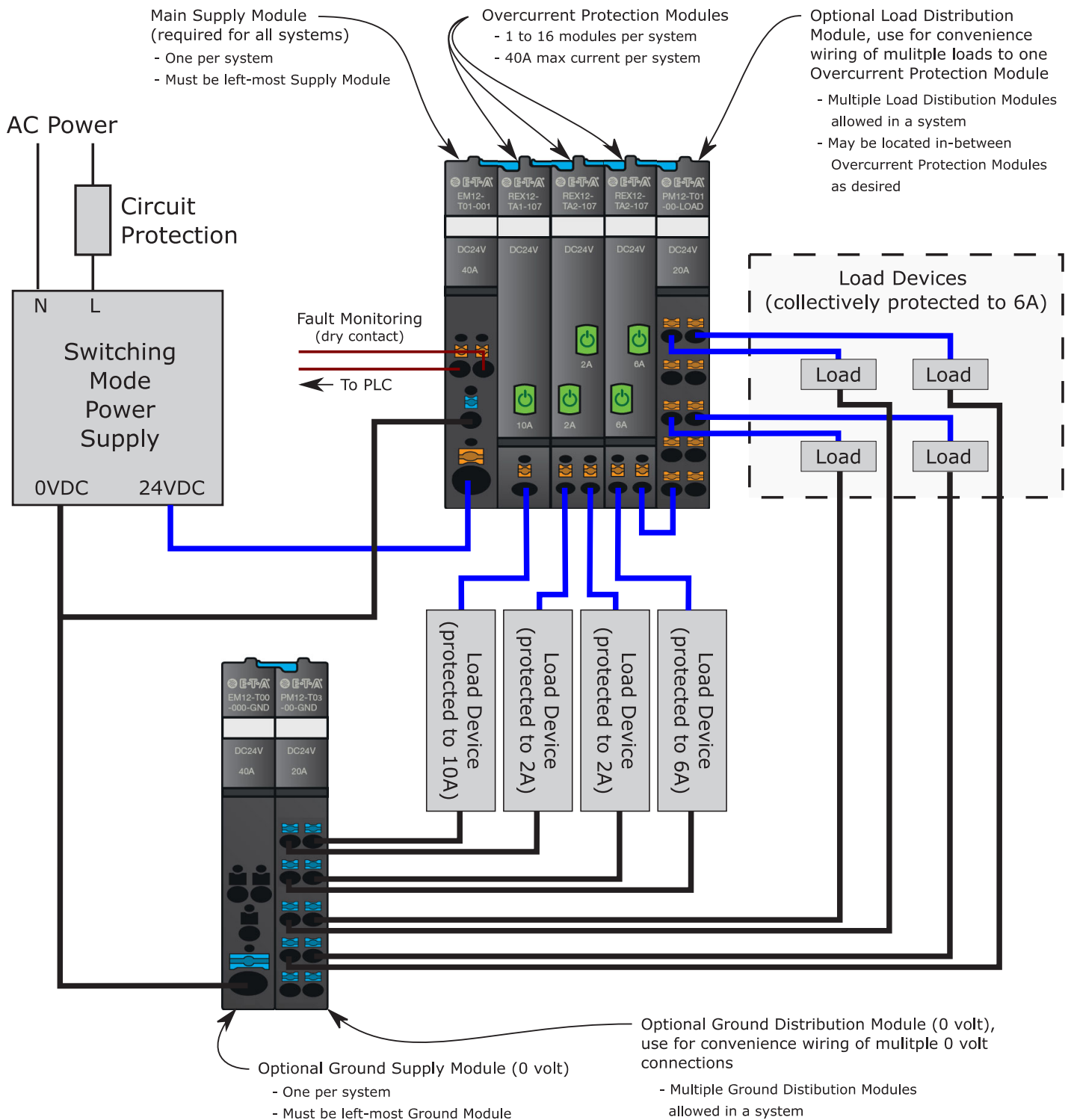



# REX Series Modular Circuit Protectors

## Specifications

REX Series Modular Circuit Protectors General Specifications	
<b>Housing Material</b>	Wellamid
<b>Mounting</b>	Symmetrical rail to EN 60715- 35 x 7.5, horizontal
<b>Ambient Temperature <math>T_u</math></b>	-25 to 60°C [-13 to 140°F] (Without condensation, cf. EN 60204-1)
<b>Storage Temperature</b>	-40 to 70°C [-40 to 158°F]
<b>Operating Temperature</b>	5 to 60°C [41 to 140°F]
<b>Humidity</b>	96 hrs / 95% RH/40°C to IEC 60068-2-78-Cab climate class 3K3 to EN 60721
<b>Altitude</b>	2,000m above sea level 3,000m above sea level up to +55 °C 4,000m above sea level up to +50 °C
<b>Operation Pressure</b>	4 bar above atmospheric pressure
<b>Vibration</b>	5g test to IEC 60068-2-6, test Fc
<b>Degree of Protection (IEC 60529, DIN VDE 0470)</b>	IP20 EM and PM modules IP30 REX modules
<b>EMC Requirements (EMC Directive, CE logo)</b>	Noise emission EN 61000-6-3 Susceptibility: EN 61000-6-2
<b>Insulation co-ordination (IEC 60934)</b>	0.5 kV / pollution degree 2
<b>Dielectric Strength (max.)</b>	30 VDC (load circuit)
<b>Insulation Resistance (OFF condition)</b>	N/A, only electronic disconnection
<b>Agency Approvals</b>	See selection chart table

To obtain the most current agency approval information, see the Agency Compliance & Certifications Checklist section on the specific part number's web page.



# REX Series Modular Circuit Protectors

## EM-T01-001-24-40A Overview

A 24VDC switch-mode power supply powers the [EM-T01-001-24-40A](#) supply module, which distributes the power through the backplane to the circuit protection modules. The supply module also provides an auxiliary, dry contact status output to signal fault conditions to a connected device such as a PLC input protector, e.g. to the PLC input.

## Specifications

EM-T01-001-24-40A Specifications	
<b>Operating Voltage <math>U_B</math></b>	24VDC 18-30VDC
<b>Operating Current <math>I_B</math> (max)</b>	40A
<b>Reverse Polarity Protection</b>	Yes
<b>Signaling</b>	Only <a href="#">EM-T01-001-24-40A</a>
<b>Quiescent Current <math>I_o</math></b>	Typically 10mA
<b>Potential-free Auxiliary (max) (Change over contact)</b>	30VDC / 0.5 A min., 10V / 1mA
<b>Group Signaling contact - (13) / (14)</b>	Auxiliary contact, make contact
<b>Group Signaling Normal Conditions</b>	Auxiliary contact closed based on all protection modules - when ON, load output connected - when OFF, load output disconnected
<b>Group Signaling Fault Conditions</b>	Auxiliary contact open based on one or more protection modules - after overload or short circuit trip - after undervoltage release of operating voltage in ON condition with autoreset - at no operating voltage $U_B$ in supply module
<b>Insulation Co-ordination</b>	0.5 kV / pollution degree 2
<b>Power Failure Buffering Time</b>	10ms max
<b>LINE + Push-in Terminal PT 10</b>	0.5 to 10mm <sup>2</sup> flexible 24-8 AWG rigid stripping length 18mm
<b>0V / 13 / 14 Push-in Terminal PT 2.5</b>	0.14 to 2.5 mm <sup>2</sup> flexible 24-24 AWG rigid stripping length 8 to 10mm

(1) [EM-T01-001-24-40A](#) is required for each system.

Maximum 16 modules or 40A max per system.

Circuit protectors can be mounted side-by-side: [REX-TA1-24-xx](#), [REX-TA2-24-xx](#) or [REXD-TE2-24-1A-10A](#)

## Wiring Diagram

**EM-T01-001-24-40A**

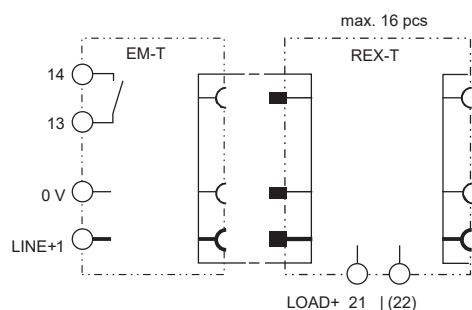



# REX Series Modular Circuit Protectors

## Specifications

REX Series Modular Circuit Protectors Entrance and Potential Modules Specifications			
Part Number	EM-T00-000-GND-40A	PM-T01-00-LOAD-20A	PM-T03-00-GND-20A
Operating Voltage $U_B$ OV	24VDC 0-30VDC		
Operating Current $I_B$ (max)	40A	20A	20A
Line Terminal	0V - GND	NA	0V - GND
Insulation Co-ordination	NA	0.8 kV / pollution degree 2	NA
LINE +	Push-in terminal PT 10 0.5 to 10 mm <sup>2</sup> flexible 24-8 AWG rigid stripping length 18mm	Push-in terminal PT 2.5 0.14 to 2.5 mm <sup>2</sup> flexible 24-14 AWG rigid stripping length 8 to 10mm	Push-in terminal PT 2.5 0.14 to 2.5 mm <sup>2</sup> flexible 24-14 AWG rigid stripping length 8 to 10mm

## Wiring Diagrams

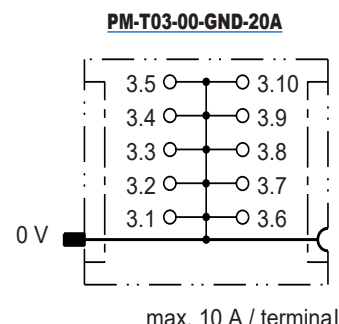
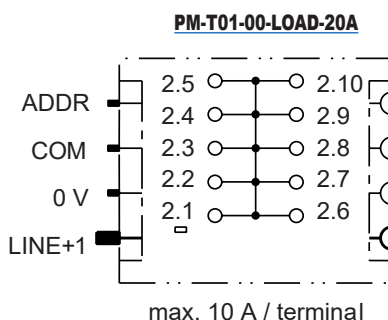
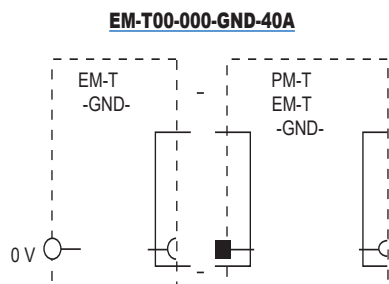



# REX Series Modular Circuit Protectors

## Specifications

REX Series Modular Circuit Protectors Entrance and Potential Modules Specifications				
Part Number	REXD-TE2-24-1A-10A	REX-TA1-24-xx	REX-TA2-24-xx	REX-TA2-24-3A-N
Operating Voltage $U_B$	24 VDC (18 to 30 VDC)			
Closed Circuit Current	1A-10A ON condition: typically 12mA	ON condition: typically 5mA	ON condition: typically 8mA	
Reverse Polarity Protection	Yes			
Power Failure Buffering Time	Up to 10ms			
Rated Current	1A – 10A condition upon delivery max. current rating	8A, 10A	2 A/2A, 4A/4A, 6A/6A	
LED Status	Green: Load circuit connected Green/orange blinking: load current warning limit reached 90 % Orange: overload or short circuit until disconnection Red: - after disconnection due to overload or short circuit - after undervoltage release of operating voltage in ON condition with auto-reset OFF: Device switched off by means of ON/OFF momentary switch or no operating voltage			
Load Output	Power MOSFET switching output (plus switching)			
Load Current Warning Limit ( $I_w$ Limit) Hysteresis	Typically $0.9 \times I_N$ Typically 5%			
Overload Current	Disconnection ( $I_{OL}$ ) typically $I_{OL} : I_N \times 1.05 t_{OL} : 3s$ typically $I_{OL} : I_N \times 1.35 t_{OL} : 0.5s$ With trip times ( $t_{OL}$ ) typically $I_{OL} : I_N \times 2.00 t_{OL} : 0.1s$ typically $I_{OL} : I_N \times 2.50 t_{OL} : 0.012 s$ Short circuit typically at short circuit ( $I_{SC}$ ) $t_{SC} : 0.002 s^2$			
Voltage Drop $I_N$	1A typically 30mV, 70% typically 28mV 2A typically 39mV, 70% typically 34mV 3A typically 48mV, 70% typically 40mV 4A typically 57mV, 70% typically 46mV 5A typically 66mV, 70% typically 52mV 6A typically 74mV, 70% typically 59mV 7A typically 83mV, 70% typically 65mV 8A typically 92mV, 70% typically 71mV 9A typically 101mV, 70% typically 77mV 10A typically 110mV, 70% typically 83mV	2A (CL2) typically 110mV, 70% typically 80mV 3A (CL2) typically 130mV, 70% typically 90mV 4A typically 115mV, 70% typically 80mV 6A typically 170mV, 70% typically 110mV 8A typically 160mV, 70% typically 105mV 10A typically 180mV, 70% typically 120mV		
Fail-safe Element Integral Blade Fuse Adjusted to Related Current Rating $I_N$	8A fail-safe 8A 10A fail-safe 10A 2A/2A (CL2) fail-safe 2A/2A 3A/3A (CL2) fail-safe 4A/4A 4A/4A fail-safe 4A/4A 6A/6A fail-safe 6.3 A / 6.3 A 1A-10A fail-safe 16A			
Operating Voltage Monitoring re Undervoltage	OFF at typically $U_B < 16.0 V$ ON at typically $U_B > 19.0 V$ hysteresis typically 2V with automatic OFF and ON switching			
ON Delay With Power ON	Channel 1: typically 1,500ms Channel 2: typically 1,600ms	Channel 1: typically 100ms Channel 2: typically 200ms		
ON Delay When Switching on With ON/OFF Switch	Channel 1: typically 5ms Channel 2: typically 100ms			
ON Delay After Undervoltage	Channel 1: typically 5ms Channel 2: typically 5ms			
Disconnection Of Load Current	Manually on the device with the ON/OFF momentary switch After an overload / short circuit disconnection with storage (no automatic reset) Temporarily at undervoltage At no operating voltage			

Continued on following page.





# REX Series Modular Circuit Protectors

Continued from previous page

Modular Circuit Protectors Specifications				
Part Number	REXD-TE2-24-1A-10A	REX-TA1-24-xx	REX-TA2-24-xx	REX-TA2-24-3A-N
Switch-on of Load Circuit	Momentary switch ON/OFF: Device can only be switched on when operating voltage is applied. Applying operating voltage: The device starts up with the condition last stored.			
Reset Function	A blocked load output (blocked by overload / short circuit) can externally be reset by the ON/OFF momentary switch.			
Leakage Current in Load Circuit if OFF Condition	Typically < 1mA			
Capacitive Loads	Up to 20,000 $\mu$ F: Depending on cable attenuation, power supply used, load current and current rating			
Free-wheeling Diode	External free-wheeling circuit at inductive load (rating according to load)			
Parallel Connection of Several Load Outputs	Not allowed			
Status Output SM	Status indicator in REX system			
Electrical Data	Minus switching signal output Group signaling is implemented in connection with <a href="#">EM-T01-001-24-40A</a> supply module.			
Terminals LOAD+	Push-in terminal PT 2.5: 0 to 14mm <sup>2</sup> [ 2 to 5mm <sup>2</sup> flexible] 24-14 AWG rigid Stripping length 8 to 10mm			

## Inquiry Mode [REXD-TE2-24-1A-10A](#)

Use Inquiry Mode to determine the current setting of the [REXD-TE2-24-1A-10A](#) module. Inquiry Mode is possible in all operating conditions (ON, OFF, UNDERVOLTAGE and TRIPPED).

1. Press and hold the button for 2 to 5 seconds to enter inquiry mode.
2. When the button is released, the LED will turn RED for 333ms to indicate that the module is in Inquiry Mode.
3. Then the LED will blink ORANGE at a pulse rate of 1Hz to indicate the current setting (number of pulses = current setting).
4. After the last pulse, the LED will turn RED for 333ms and flash the current setting again.
5. Press the button or wait for five indication cycles to exit Inquiry Mode.

## Adjustment Mode [REXD-TE2-24-1A-10A](#)

Use Adjustment Mode to set the [REXD-TE2-24-1A-10A](#) module to the desired current setting. Adjustment Mode is possible in all operating conditions (ON, OFF, UNDERVOLTAGE and TRIPPED).

1. Press and hold the button for at least 5 seconds to enter Adjustment Mode.
2. When the button is released, the LED will turn RED for 333ms to indicate that the module is in Adjustment Mode.
3. The LED will blink GREEN at a pulse rate of 0.6 Hz for the desired current setting (number of pulses = current setting).
4. Once the maximum value is indicated, the LED will turn RED for 333ms and repeat the cycle.
5. To select a current setting, wait for the LED to flash the desired number of times, then press the button (for example, pressing the button after seven pulses will change the setting to 7A).
6. Adjustment Mode will be exited when a setting is selected or if no selection is made after five indication cycles.



# REX Series Modular Circuit Protectors

## Typical Time/Current Characteristic

( $T_{amb} = +23^{\circ}\text{C}$ , UB - 24VDC)

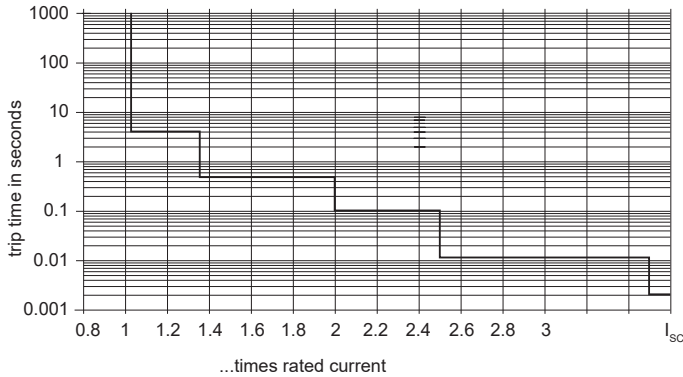

## Basic Trip Curve and Schematic Diagram REX-T

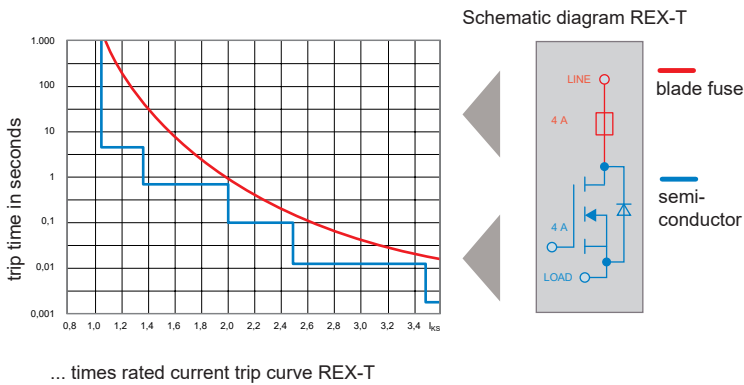

## Temperature Factor / Continuous Duty

The time/current characteristic depends on the ambient temperature. To determine the maximum load current, please multiply the current rating with the temperature factor and consider the factor for side-by-side mounting.

Temperature Factor Table						
<b>Ambient Temperature [°C]</b>	0	10	23	40	50	60
<b>Temperature Factor</b>	1	1	1	0.95	0.90	0.85

**Note:**

When mounted side-by-side, the devices can carry a maximum of 80% of their rated load or a different rating must be selected.

With high temperatures, the load current warning threshold "warn limit typically  $0.9 \times I_N$ " will be reduced in accordance with the temperature factor.

Selection of current rating of the circuit protector  $\leq$  rating of power supply.

# REX Series Modular Circuit Protectors

## Mounting Diagram

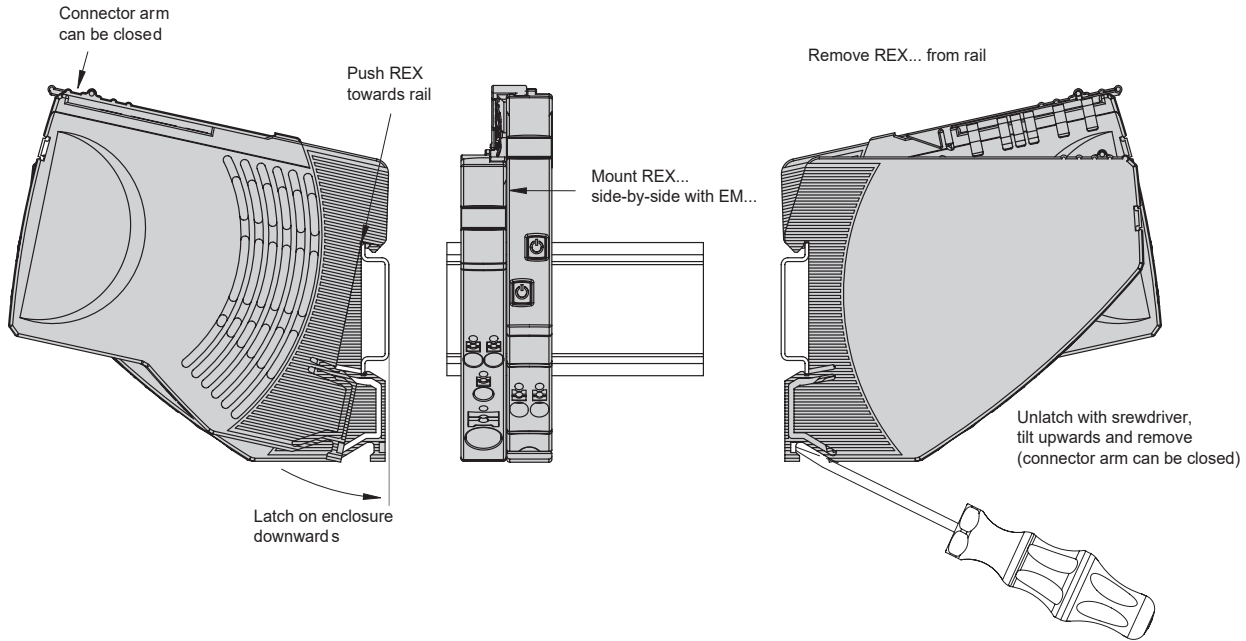

## Replacement Diagram

