

RHINO PSB24-BCM960S Battery Control Module

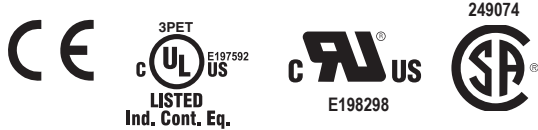

General Description

The PSB24-BCM960S battery control module is designed to support a 24V system with up to 40A output and 4.5 minutes back up time for 15AH battery capacity. It offers a wide input voltage from 24-28V and a wide operating temperature range from -20°C to 60°C. This product comes with dry contacts for battery management signals and LED indicator for battery status. The rugged compact aluminum case is shock and vibration resistant according to IEC 60068-2.

Features

- Full corrosion resistant Aluminum chassis
- Suitable for 24V system up to 40A
- Built-in diagnostic monitoring for DC OK, Discharge and Battery Fail by relay contacts
- LED indicator for DC OK, Battery Fail, DC Input, Battery Reverse Polarity and Battery Discharge
- High MTBF > 500,000 hrs as per Telcordia SR-332
- Wide operation temperature range from -20 to 60°C
- Conformal coating on PCBA to protect against chemical and dust pollutants

Device description (Fig. 1)

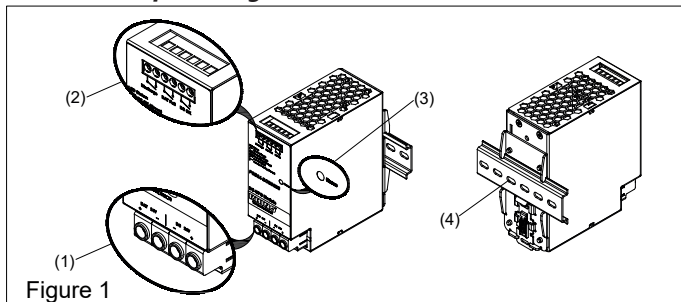

1. Input & Output/Battery terminal block connector
2. Signal terminal block connector
3. LED display status
4. Universal mounting rail system

RHINO PSB24-BCM960S Battery Control Module

Mounting

The unit can be mounted on 35mm DIN rails in accordance with EN60715. For vertical mounting, the device should be installed with Input & Output/Battery terminal block on the bottom. For horizontal mounting, the device should be installed with Input & Output/Battery terminal block on the left side.

Each device is delivered ready to install.

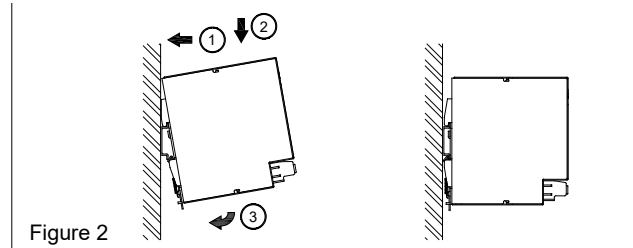

Snap on the DIN rail as shown in Fig. 2:

1. Tilt the unit slightly upwards and put it onto the DIN rail.
2. Push downwards until stopped.
3. Press against the bottom front side for locking.
4. Shake the unit slightly to ensure that it is secured.

Dismounting

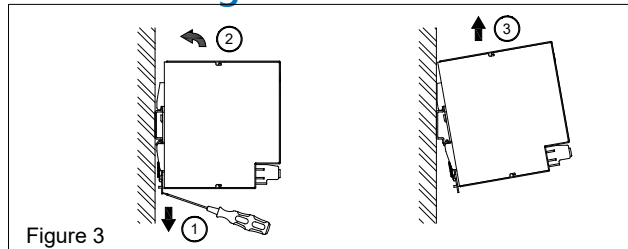

To uninstall, use a flat screwdriver to pull or slide down the latch as shown in Fig. 3. Then, slide the PSU in the opposite direction, release the latch and pull out the PSU from the rail.

Orientation

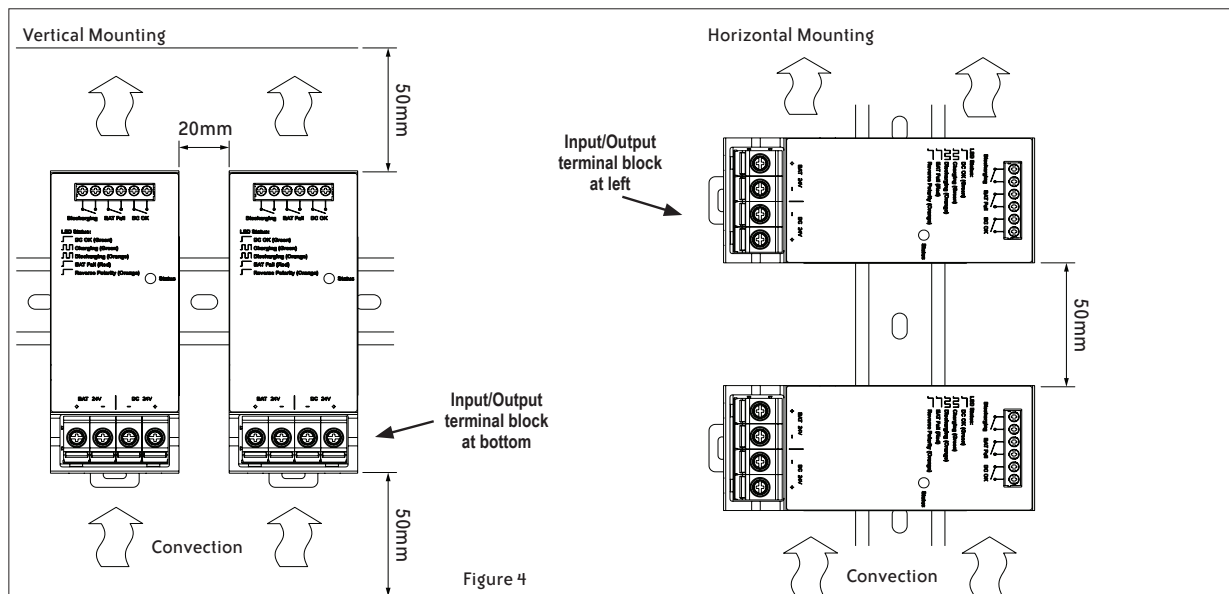

Connection

The terminal block connectors allow easy and fast wiring. The terminal block is IP20 compliant and thus provides the user safety and protection from electrical shock hazards.

You can use flexible (stranded wire) or solid cables as follows:

Electrical Connections and Wire Size					
	Stranded / Solid		Torque		Remarks
	mm ²	AWG	N·m	lb·in	
Battery	3.3-13.3	12-6	1.52	13.5	Load: 0-20A
DC In/Out	8.4-13.3	8-6	1.52	13.5	Load: 20-40A
Signal	0.2-3.3	24-12	0.61	5.4	-

Wires between the battery control module and battery must not be longer than 2m [6.5 ft]. For reliable and shockproof connections, the wire stripping length should be 10mm for Input & Output/Battery terminal block connector and 7mm for Signal terminal block connector (see Fig. 5 (1)). Please ensure that wires are fully inserted into the connecting terminals as shown in Fig. 5 (2).

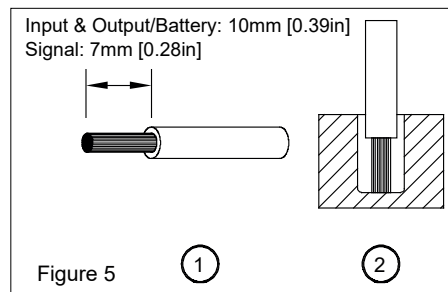

In accordance with EN60950 / UL60950, flexible cables require ferrules.

Use appropriate copper cables that are designed to sustain operating temperature of at least 60°C/75°C for USA or at least 90°C for Canada.

RHINO PSB24-BCM960S Battery Control Module

Signal wiring diagram

Contact current: $I_{max} = 1A$
 Contact voltage: $V_{max} = 24VDC/VAC$ (Secondary circuit)
 No polarity requirement.

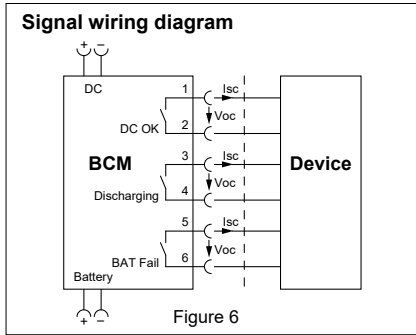

Power Derating

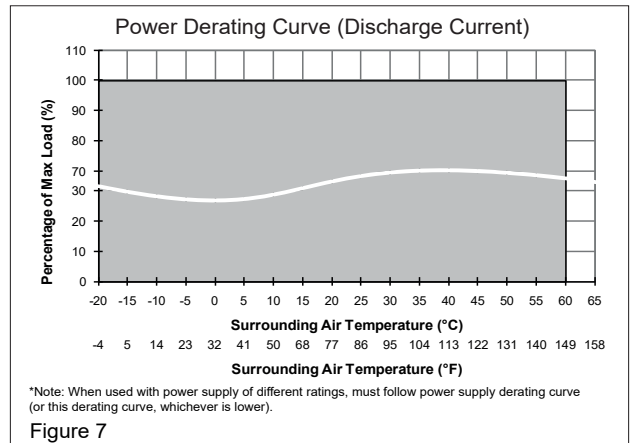

Status Indicators				
BCM Status	Relay Output Connector			LED Display Status
	Discharging	BAT Fail	DC OK	
Battery Fully Charged	Open	Open	Closed	Green LED On
Battery Charging	Open	Open	Closed	Green LED Flashing
Battery Discharging* [Buffering Mode]	Closed*	Open	Closed	Orange LED Flashing
No Battery Connected	Open	Closed	Open	Red LED On
Output Shutdown	Open	Open	Open	No Light

* With output current 3A to 40A.

Buffering Time

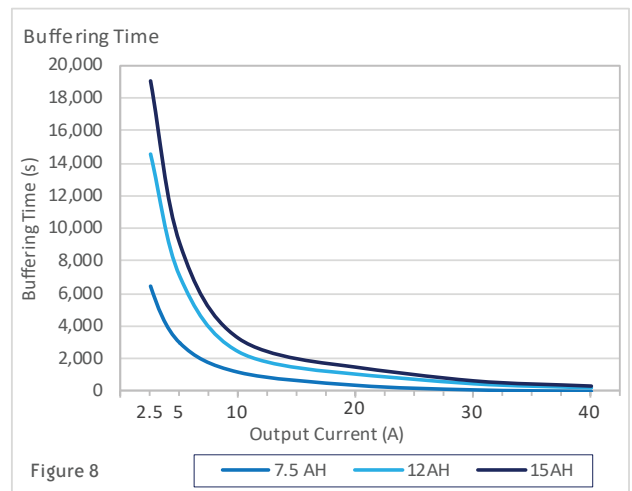

Buffering Time			
Output Current	7.5 AH	12AH	15AH
2.5 A	6,500s	14,500s	19,000s
5A	3,000s	7,000s	9,000s
10A	1,200s	2,400s	3,200s
20A	400s	1,100s	1,500s
30A	120s	450s	600s
40A	25s	200s	280s

Typical application notes

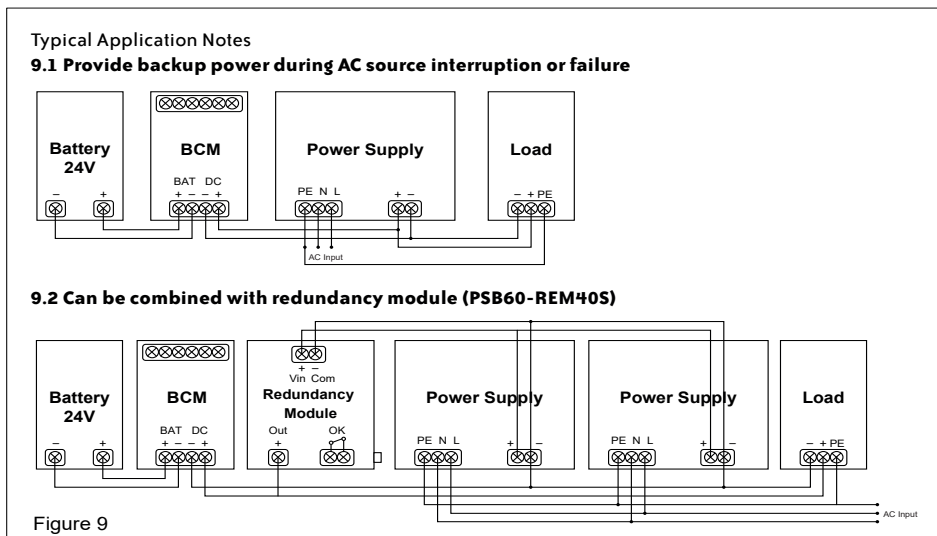





RHINO PSB24-BCM960S Battery Control Module

Technical Specifications	
Input (DC)	
Nominal input voltage	24VDC
Voltage range	24-28VDC
Maximum input voltage	30 ± 0.5 VDC
Input current	Charging Mode: 2.0 ± 1.0 A [25°C], Discharging Mode: 40A Max.
Maximum inrush current (cold start)	< 45A [25°C]
Charging time	< 3 hr ± 1 hr [25°C]
Efficiency	Charging Mode: > 70.0%, Discharging Mode: > 99.0%
Output (DC)	
Nominal output voltage	24VDC typ. [depends on Vin]
Discharging voltage	23-28 VDC
Maximum output voltage	30 ± 0.5 VDC
Output current	40A Max.
Derating	Refer to Fig. 7
Component derating	Vin = 28.0 VDC, Max. load
Short circuit / Overload	No damage
Batteries	
Recommended battery types	24V VRLA or 2 x 12V VRLA
Recommended battery capacity	7.2-15.0 Ah
Battery voltage range	23-28VDC [continuous operating], 30VDC Max [maximum voltage that will not cause damage to the unit] 14VDC Min [voltage level of battery to enable "BAT Fail" function]
Battery fuse	Auto 50A / 80V, FK3 [Littelfuse] or similar in the battery path [protects the wires between the battery and the battery control module]
General Data	
Type of housing	Aluminum
LED signals	Green LED On = Unit is fully charged Green LED Flashing = Unit is charging Orange LED Flashing = Unit is discharging Red LED On = Battery fail (no battery is connected) Orange LED On = Battery 24 V or DC 24 V reverse polarity
Signal relay contacts	DC OK = Contact is closed when battery is fully charged and the unit is ready to discharge/buffer. DISCHARGING = Contact is closed when the unit is discharging/buffering with output current of 3-40 A. BATTERY FAIL = Contact is closed when the battery fails to function.
MTBF	> 500,000 hrs. as per Telcordia
Weight	0.39 kg [14 oz]
Connection method	Screw connection
Stripping length	Input & Output/Battery terminal block connector: 10mm [0.39 in] Signal terminal block connector: 7mm [0.28 in]
Operating temperature (surrounding air temperature)	-20 to 60°C [-4 to 140°F] [Refer to Fig. 7]
Storage temperature	-25 to 85°C [-13 to 185°F]
Humidity at +25°C, no condensation	< 95% RH
Vibration (non-operating)	10Hz to 500Hz @ 30m/S ² [3G peak]; displacement of 0.35mm; 60 min per axis for all X, Y, Z direction. Refer to IEC60068-2-6. Note: all figures quoted are amplitudes [peak values]
Shock (in all directions)	30G [300m/S ²] in all directions according to IEC60068-2-27
Pollution degree	2
Altitude (operating)	3000m

Continued on next page.

RHINO PSB24-BCM960S Battery Control Module

Technical Specifications (continued)

Certification and Standards							
Electrical equipment of machines	IEC60204-1						
Electronic equipment for use in electrical power installations	EN50178 / IEC62103						
Safety entry low voltage	PELV [EN60204], SELV [EN60950]						
Electrical safety (of information technology equipment)	UL/C-UL recognized to UL60950-1 and CSA C22.2 No. 60950-1 File No. E198298, CB scheme to IEC60950-1						
Industrial control equipment	UL/C-UL listed to UL508 and CSA C22.2 No.107.1-01, CSA to CSA C22.2 No.107.1-01 File No. 249074						
Protection against electric shock	DIN57100-410						
CE	In conformance with EMC directive 2014/30/EU and Low Voltage Directive 2014/35/EU						
Component power supply for general use	EN61204-3						
Immunity	EN55024, EN61000-6-2 [EN61000-4-2, 3, 4, 5, 6, 8]						
Emission	EN55032, EN55011						
Agency Approvals	   						
RoHS Compliant	Yes						
Safety and Protection							
Isolation voltage:	<table border="1"> <tr> <td>Input & Output / PE</td> <td>1kVAC</td> </tr> <tr> <td>Signal / PE</td> <td>1kVAC</td> </tr> <tr> <td>Input & Output / Signal</td> <td>1kVAC</td> </tr> </table>	Input & Output / PE	1kVAC	Signal / PE	1kVAC	Input & Output / Signal	1kVAC
Input & Output / PE	1kVAC						
Signal / PE	1kVAC						
Input & Output / Signal	1kVAC						
Polarity protection	Yes						
Protection degree	IP20						
Safety class	Class III						

RHINO PSB24-BCM960S Battery Control Module

Block Diagram

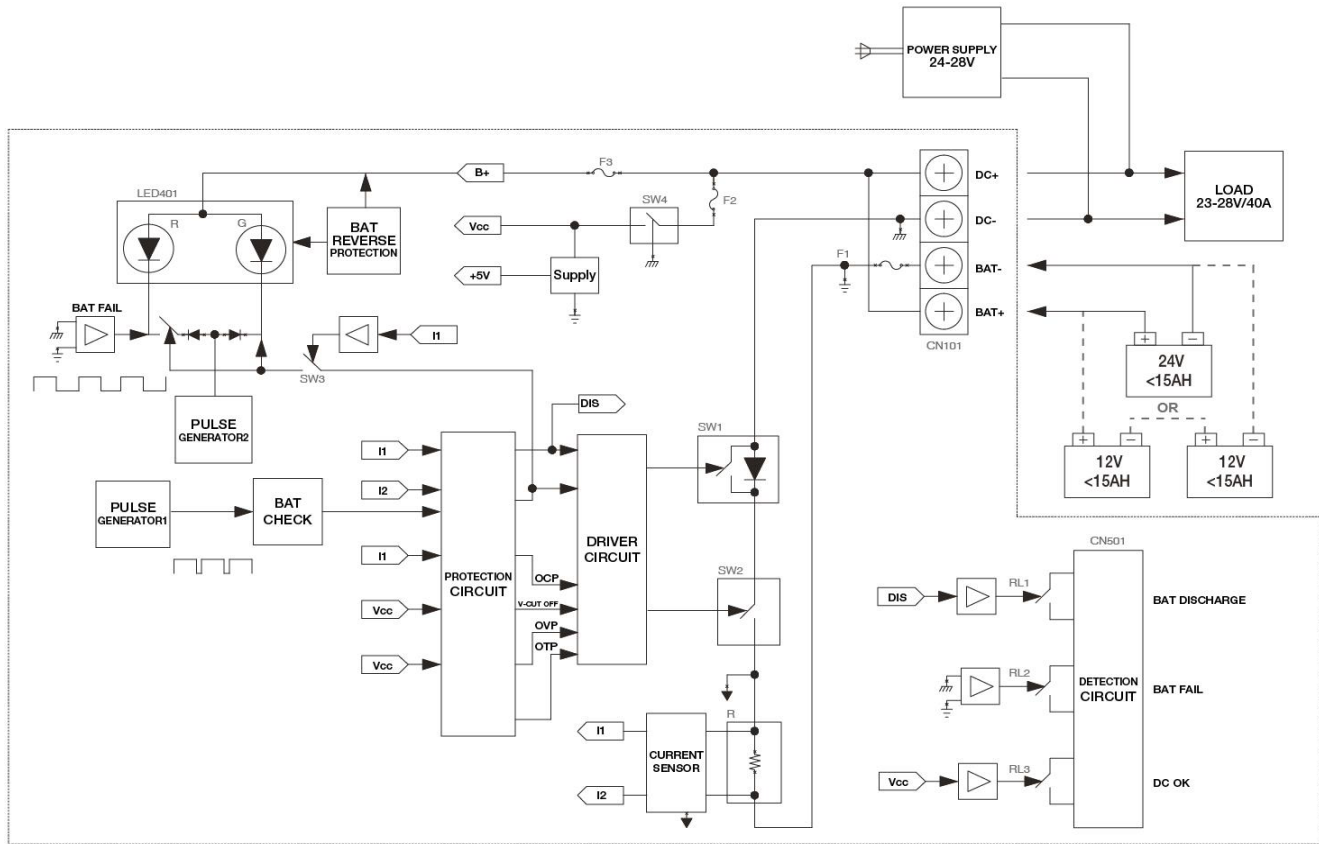

RHINO Battery Control Modules Overview

A battery control module (BCM), in combination with an external sealed lead acid battery, can be added to a DC power supply to create a DC uninterruptible power supply (UPS) that will maintain power to a connected load upon loss of mains power.

The battery control module performs several key functions in the DC UPS system. Under normal conditions, it monitors the status of the DC input power, monitors and controls charging of the external lead acid battery, and provides status/alarm contacts to allow remote monitoring of the state of the UPS.

In the event that the DC power supply voltage drops out, the BCM monitors and supplies power to the load from the battery and monitors the battery during discharge.

Several battery control modules, with a range of features, are available for use with RHINO power supplies. Key differentiating features of the battery control modules are delineated in the following table.

Battery Control Module Selection Guide				
Part Number	<i>PSH-BCM360S</i>	<i>PSB24-BCM960S</i>	<i>PSL-24-BCM240</i>	<i>PSM24-BCM360S</i>
Price	\$242.00	\$66.00	\$34.50	\$196.00
Drawing Link	PDF	PDF	PDF	PDF
Highlights	Most versatile	Highest power Lowest cost/watt Conformal coating	Lowest cost	Legacy
Nominal Output Voltage	24/48 VDC	24 VDC	24 VDC	24 VDC
Amperage Rating	15A at 24 VDC, 7.5 A at 48 VDC	40A	10A	15A
Number of Power Inputs	Redundant inputs for two independent power supplies	One power supply	One power supply	One power supply
Battery Type	12V sealed lead acid	24V sealed lead acid	24V sealed lead acid	24V sealed lead acid
Protection Type	Over voltage, Over current, Deep discharge, Reverse polarity, Battery overcharge, Over temperature			
Battery Temperature Compensation	Yes	No	No	Yes
Compatibility	Universal	Universal	Universal	Requires RHINO PSM24 power supply

