

# pro<sup>sense</sup> FSD Series Flow Switches

Part No. [FSD75-AP-6H](#)Part No. [FSD1-AP-26H](#)

## Overview

The ProSense FSD Series flow switches monitor liquid media and provide reliable flow detection for various flow applications.

The ProSense FSD Series sensing principle ensures extremely fast response time and allows for a more precise setpoint setting. The setpoint can be easily set and locked with a setting screw.

The ProSense FSD Series flow switches are ideal for applications with rapid temperature changes or where fast response time is required, such as:

- Machine tool coolant flow
- HVAC cooling water flow
- Injection molding cooling water flow

## Features

- Monitor 0.26 to 26.4 GPM (gallons per minute) in 2 models
- Immune to rapid temperature changes of media
- Fast response time of 10ms: great for cycling applications with a minimum of 10 million switching cycles
- Easy to set: turn dial to desired setpoint
- Able to be bench set outside the process
- 3/4" or 1" FNPT process connections
- Integrated check valve design allows the sensor to be mounted horizontally or vertically
- 4-pin M12 quick-disconnect
- IP65 / IP67
- LED output status indication
- 2-year warranty



#E320431

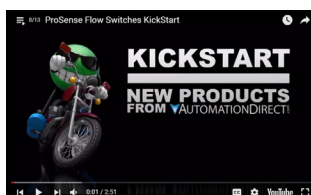

Click on the thumbnail or go to <https://www.automationdirect.com/VID-FL-0001> for a short introductory video on the FSD Series Flow Switches

## ProSense FSD Series Flow Switches

| Part No.                    | Description  | Quantity | Weight (lbs) | Price    |
|-----------------------------|--|----------|--------------|----------|
| <a href="#">FSD75-AP-6H</a> | 24VDC, 0.26 to 6.6 GPM setpoint range, rotating dial adjustment with lock screw, 26.4 GPM max flow rate, nickel-plated brass housing with 3/4 in. FNPT process connections, N.O. DC PNP output. Cable sold separately. | 1        | 1.0          | \$151.00 |
| <a href="#">FSD1-AP-26H</a> | 24VDC, 1.32 to 26.4 GPM setpoint range, rotating dial adjustment with lock screw, 52.8 GPM max flow rate, nickel-plated brass housing with 1 in. FNPT process connections, N.O. DC PNP output. Cable sold separately.  | 1        | 1.6          | \$182.00 |

## ProSense FSD Series Flow Switches Technical Specifications

| Model                       | FSD75-AP-6H   | FSD1-AP-26H     |
|-----------------------------|---|-----------------|
| Operating Voltage           | 20.4 to 26.4 VDC (must use a Class 2 power supply in order to comply with UL508 requirements) |                 |
| Electrical Connection       | M12 (note: tightening torque < 0.6 Nm based on cable)   |                 |
| Connection Pin Material     | Gold-plated   |                 |
| Output Function             | Normally open (PNP)   |                 |
| Output Maximum Load Current | 100mA   |                 |
| Current Consumption         | < 15mA  |                 |
| Voltage Drop                | < 2.5 VDC   |                 |
| Short-Circuit Protection    | YES   |                 |
| Reverse Polarity Protection | YES   |                 |
| Overload Protection         | YES   |                 |
| Switching Cycles Minimum    | 10 million  |                 |
| Response Time               | 10ms  |                 |
| Accuracy*                   | ± 5% of full range  |                 |
| Repeatability               | 0.06 GPM  | 0.26 GPM        |
| Process Connection          | 3/4" FNPT   | 1" FNPT         |
| Medium                      | liquids (water, glycol solutions, oils)   |                 |
| Maximum Viscosity           | <68 centistokes   |                 |
| Maximum Flow Rate           | < 26.4 GPM  | < 52.8 GPM      |
| Setpoint Range              | 0.26 – 6.6 GPM  | 1.32 – 26.4 GPM |
| Hysteresis                  | 0.13 – 0.53 GPM   | 0.8 – 1.58 GPM  |
| Pressure Rating             | 362PSI  |                 |

\*when used with water

# FSD Series Flow Switches

| ProSense FSD Series Flow Switches Environmental Specifications |   |             |
|--|---|-------------|
| Model  | FSD75-AP-6H   | FSD1-AP-26H |
| Housing Material   | Brass chemically nickel plated; aluminum anodized; POM  |             |
| Materials (wetted parts)                                       | Stainless steel (304S15); Brass; brass chemically nickel plated*; PP (Polypropylene); POCAN PBT (Polybutylene terephthalate); O-ring: FPM (Viton) |             |
| Operating Temperature  | 32 to 140°F (0 to 60°C)   |             |
| Medium Temperature   | 32 to 185°F (0 to 85°C)   |             |
| Storage Temperature  | -40 to 212°F (-40 to 100°C)   |             |
| Protection   | IP65 / IP67   |             |
| Protection Class   | III   |             |
| Agency Approvals   | cULus (#E320431), CE, RoHs  |             |

\* The brass contains between 1-2% lead by weight. Not recommended for use in potable water applications.



Note: Check the chemical compatibility of the sensor's wetted parts with the medium to be measured.

## Wiring Diagrams

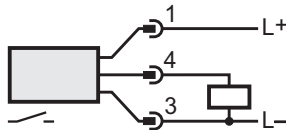
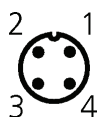

### Cable Assembly Wiring Colors:

- Pin 1 - Brown
- Pin 2 - White
- Pin 3 - Blue
- Pin 4 - Black

Note: Wiring colors are based on AutomationDirect CD12L and CD12M 4-pole cable assemblies.

## LED Functions

The FSD units monitor the flow of liquid media such as: water, glycol solutions, and oils. The LED functions are as follows:

- Output closed (LED = ON), if volumetric flow quantity M setpoint.
- Output open (LED = OFF), if volumetric flow quantity I setpoint.

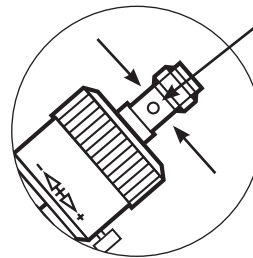

There are 4 LEDs (one on each side) on the top connector for easy visibility regardless of installation orientation.

## Installation\*:

For proper flow switch operation, the sensor should be installed as indicated in the illustrations below (noting the flow direction arrow on the body of the sensor):

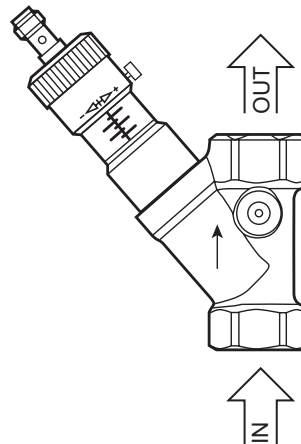
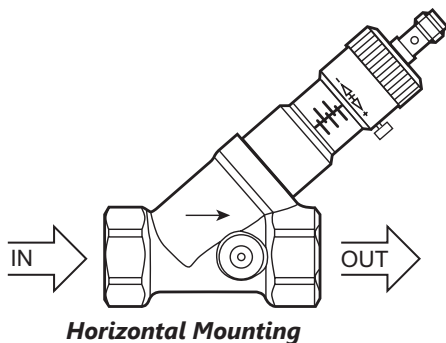

\* Integral check valve design allows the sensor to be mounted in any position (horizontally or vertically).

# FSD Series Flow Switches

## Pressure Loss/Flow Rate\*

### FSA75-42-6H

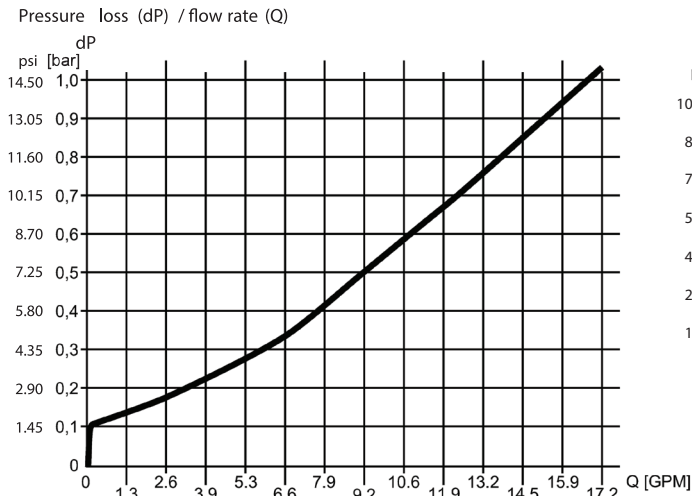

### FSD1-AP-26H

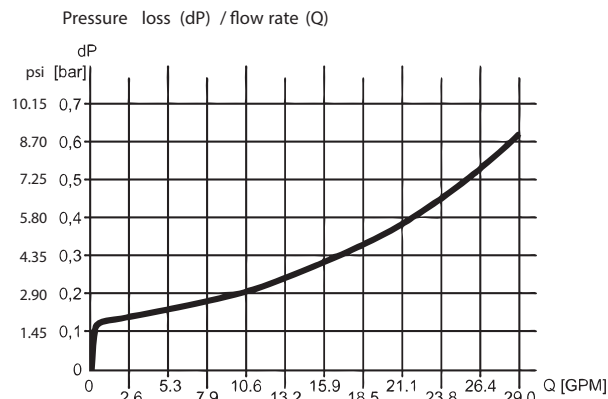

\*when used with water

## Dimensions

mm [inches]

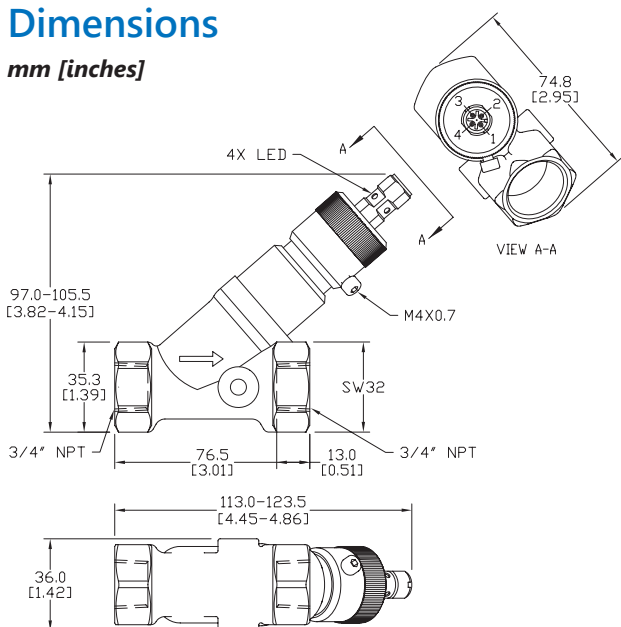

Part No. FSD75-AP-6H



Click or scan the above QR code to be taken to the installation insert for the FSD75 Series Flow Switches

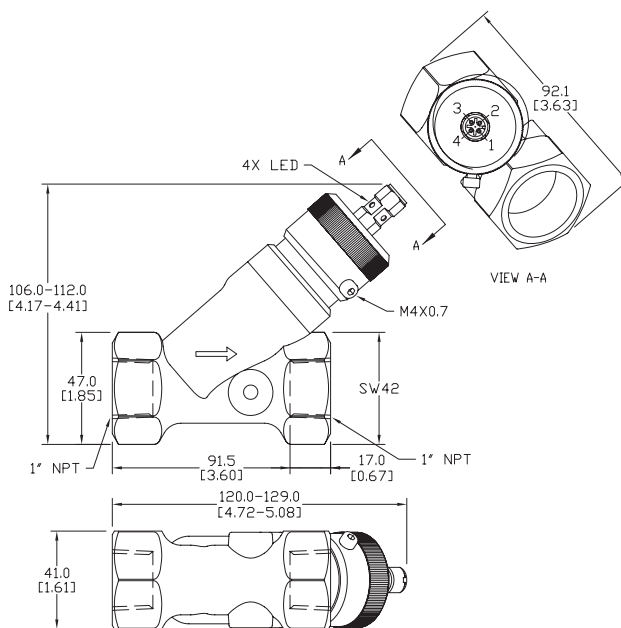

Part No. FSD1-AP-26H



Click or scan the above QR code to be taken to the installation insert for the FSD1 Series Flow Switches

See our website [www.AutomationDirect.com](http://www.AutomationDirect.com) for complete Engineering drawings.

## Operation & Setting

The flow sensor utilizes a spring-supported piston that is lifted by the flowing medium. The piston position is detected via an inductive sensor and is output as a binary signal. The spring resets the piston to its initial position with decreasing flow. This allows the sensor to be mounted in any position (horizontally or vertically) and function as a check valve.

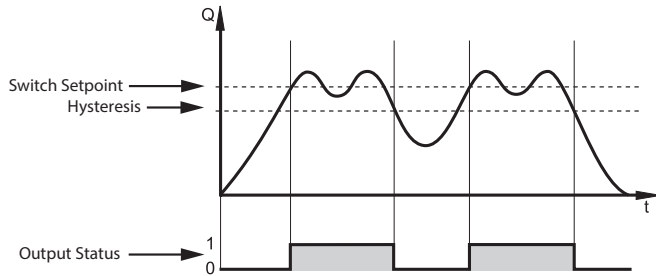

Note: Hysteresis varies based on switch setpoint.



Cutaway View

Setting FSD Series flow switches is quick and easy. There are two ways to set the flow switches - using a desired flow value and adjustment to existing flow.

### Setting the ProSense FSD using a desired flow value

- 1. Loosen the locking screw.
- 2. Set the switching point by rotating the Setpoint dial until the desired flow value just becomes visible on the setting scale.
- 3. Tighten the locking screw.

Example in Figure 1: desired value = 2 GPM

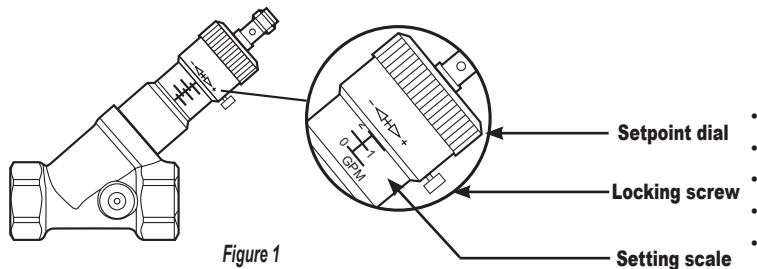

Figure 1

### Adjustment to existing flow

- 1. Let the normal flow circulate in the installation.
- 2. Loosen the locking screw.
- 3. Set the switching point by rotating the Setpoint dial.
  - If the LED lights before setting: turn the Setpoint dial in the direction [+] until the LED goes out. Then turn in the opposite direction [-] until the LED lights.
  - If the LED does not light before setting: turn the Setpoint dial in the direction [-] until the LED lights.
- 4. Tighten the locking screw.

Correlation between the number of turns of the Setpoint dial and the switching point is that one complete turn of the Setpoint dial corresponds to an approximate gallons per minute rate. This is shown in the table below:

| Part Number        | Gallons/Minute | Max. Gallons/Minute* |
|--------------------|----------------|----------------------|
| <b>FSD75-AP-6H</b> | 0.8 GPM        | 6.6 GPM              |
| <b>FSD1-AP-26H</b> | 3.3 GPM        | 26.4 GPM             |



Do not turn the setting screw beyond the maximum value of the setting range to avoid faulty switching.