



Pneumatic Pushbuttons, 22mm

NITRA® pneumatic pushbuttons are all plastic and come with adapters to allow mounting of up to two 3-way valves, or one valve and one to three contact blocks. They fit in a standard 22.5mm hole, just like electrical pushbuttons.

Features

- Plastic bezel and button
- Valve adapters and mounting screws included
- Valves sold separately
- Bases will work with GCX plastic operators and **only** the three ECX Series contact blocks shown below



Pushbutton Specifications	
Operating Temperature	-13 to 158°F (-25 to +70°C)
Storage Temperature	-40 to 176°F (-40 to +80°C)
Mechanical Life	1,000,000 cycles
Switching Cycles	3600 cycles/hr
Mounting (Valve)	(4) M3x5 valve mounting screws included
Protection	IP65 after installation
Approvals	CE

Adapter Block Installation

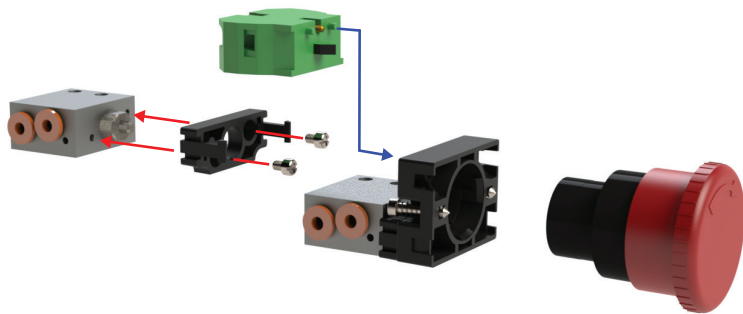
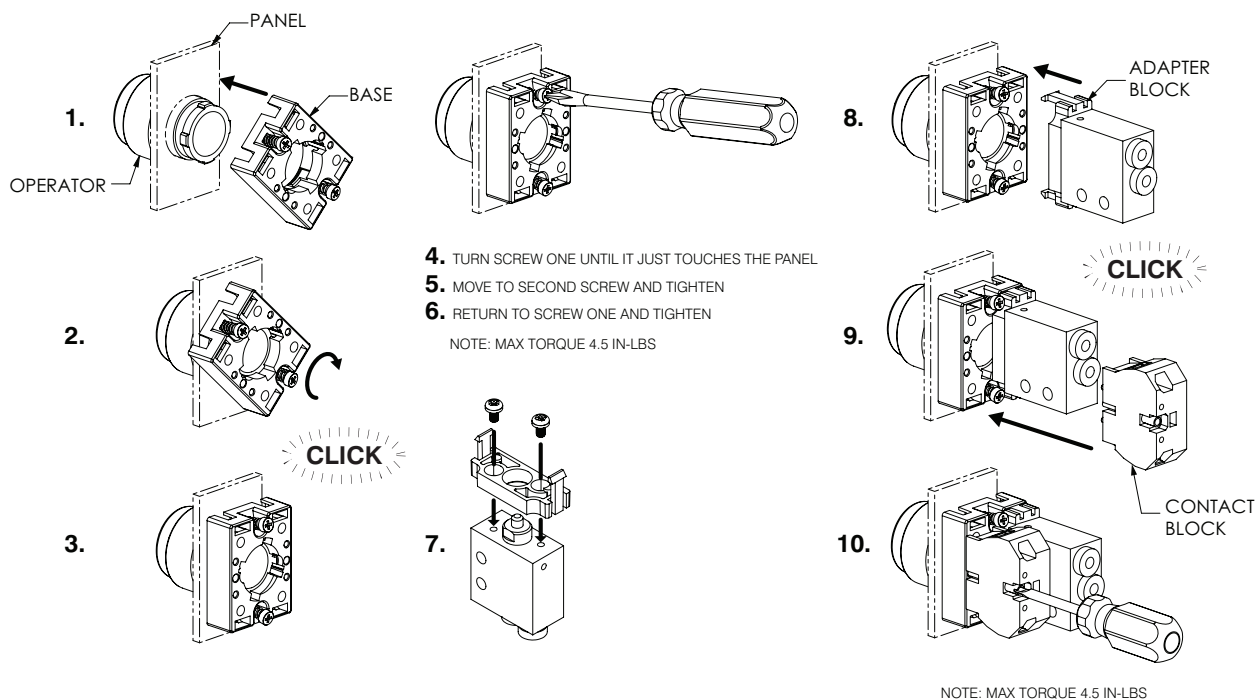

ECX1040-2



ECX1042-2



ECX1030-2