

Photoelectric Sensor

Background suppression

These sensors function in an identical manner to energetic diffuse sensors, but using the angle of incidence, rather than the amount of reflected light. For this reason, the operating distance depends only to a slight extent on the target's size, color, or surface nature. The target can therefore be accurately recognized even on a light background.

Break N.C. (normally closed)

This feature causes load current to flow when a target is not detected and not to flow when a target is detected.

Clearance

The photo sensors must not be mutually influenced. For this reason, a minimum distance between sensors has to be provided. This distance depends strongly upon the model used and the actual sensitivity setting.

Correction factors

The specified operating distance s refers to exactly defined measuring conditions (see sensing distance in specifications tables). Other arrangements generally result in a reduction of the operating distance. When this occurs, a correction factor must be applied.

DC out:

A sensor with two power supply wires and two optically decoupled output terminals. Because of its decoupled static relay, it is capable of offering NPN, PNP, parallel and series configurations as well as interfacing with any input desired. The changeover (make-break) function allows switching from N.O. to N.C. and vice versa by simply reversing the polarity of the power supply leads, allowing complex logical functions.

Diffuse-reflection photosensor

With this type of device, the emitter and receiver form part of the same unit. The optical beams are either parallel or slightly converging. The presence of an object in the optical field causes diffused reflection of the luminous beam. The receiver detects the reflection from the object itself. The reflective properties of the object are important. It is generally possible to reliably detect the presence of any object unless it is perfectly reflective or black. Clear objects with a reflective power of

90% are detected close to the rated operating distance. Dark objects with 18% reflectivity are detected at about half the normal operating distance.

Dual Teach function

Teach 1: With no target present, the operating distance is automatically adjusted to the available background in such a way that the background will not be detected. Thus, with respect to the target, maximum excess light is achieved.

Teach 2: The teach process takes place in two stages; the first on the target, the second on the background. The device subsequently sets the operating distance to an intermediate value. This provides the best results where there is little difference in signal strength between the target and the background. The Adjust mode can be used to manually tune the detection zone or to fine tune after using the either Teach function.

Excess light indication Gain

The excess light indication circuit senses the excess radiation power that falls upon the light incidence surface and is processed by the light receiver. The excess light can decrease in time due to dirt, change in the reflection factor of the object, and aging of the emitter diode, so that reliable operation may no longer be guaranteed. Some of the units are therefore equipped with a second LED (green) which lights up when more than approximately 80% of the available operating distance is used. Given this situation in units without the second green LED, the yellow LED will flash. Models with an excessive light output make the excess light signal available to the user for further processing. Unreliable operating conditions may be checked by the control system.

Inductive-load Protection

Unless otherwise stated, DC sensors are fitted with an inductive-load (surge) protection which consists of a diode or Zener diode.

IR light

IR is the abbreviation for Infrared. This refers to any electromagnetic radiation with a wavelength longer than that of normal visible light (wavelength range approx. 380 to 780 nm). Wavelengths of approx. 780 to 1500 nm are used. IR light cannot be used with plastic fibers due to

their high attenuation in this range. Red light is used instead. Usual polarization filters do not work properly in the IR range, therefore red light is also used for reflex sensors.

Leakage current

The leakage current is the current that passes through the output transistor when it is blocked. This must be taken into account, especially in the case of parallel connection of several sensors.

Load resistance

From the selected supply voltage U_B and the specified maximum output current of the photoelectric sensor, the lowest permissible load resistance for trouble-free operation can be calculated. With a voltage of 24V and a specified maximum output current of 200 mA, the minimum load resistance is 120 Ohms; for 15V, the value is 75 Ohms ($R=V/I$. In this example, $120 \text{ Ohms} = 24V/.2A$).

Make-break or complementary function:

A switching element combination that contains one make function and one break function.

In order to establish a relationship between the two different modes, you must distinguish between type D sensors (light diffusion) and types R and T (light reflection or transmission):

Type	Dark operate	Light operate
Diffuse Reflective	N.C.	N.O.
Retroreflective	N.O.	N.C.
Through-beam	N.O.	N.C.

Photoelectric Sensor

Make N.O. (normally open)

Causes load current to flow when a target is detected and not to flow when a target is not detected.

Open collector

An output transistor is not internally connected to a pull-up or pull-down load in an open collector model. Therefore, it is possible to connect an external load supplied by an external voltage. If the output is not the open-collector type, it is possible for the load to be supplied by an external voltage using a blocking diode in series with the output. This solution increments the output voltage drop.

Optical fibers

An optical fiber consists of:

- A core through which the light is transmitted
- A lining that ensures reflection of the light and keeps it within the core
- A sheath that protects the actual fiber from the outside environment

The light travelling inside the fiber is reflected by the surface separating the core from the lining. This is because the refractive index of the core is greater than that of the lining. In order for a light ray to enter the fiber, it must reach the surface of the fiber with an angle of incidence lower than the critical angle limit, which is the angle beyond which the rays enter the lining and are scattered onto the protective covering.

Standard: OF Series, "uncuttable" fiber, with special connection for MSF amplifier.

Acceptance angle

The acceptance angle is the angle inside which a light ray is accepted by the fiber. It is also the angle with which the light is discharged from the fiber. This angle produces the size of the spot generated by a fiber photocell.

For plastic fibers, the opening angle is 60°; for glass fibers, it is 70°.

Attenuation

Attenuation is the reduction in signal power caused by the length of the fiber. This parameter must be considered if using fibers with length greater than the standard size.

Installation

- Do not subject the fibers to a tractive force exceeding 3 kg.
- Keep the radius of curvature as wide as possible.
- Do not bend near the amplifier or termination.
- Secure the fibers using nylon fairleads or cable clamps to avoid causing pressure that could deform the fiber.
- Adjust the ring nut using the following maximum torque wrench settings:
 - M7: 4.5 Nm (39.83 lb-in)
 - M6: 1.2 Nm (10.62 lb-in)
 - M4: 0.8 Nm (7.08 lb-in)
 - M3: 0.8 Nm (7.08 lb-in)
- Set the smooth terminations of the optical fiber using a dowel following the maximum torque wrench settings:
- \varnothing (diameter) = 3 mm: 0.25 Nm (2.2 lb-in)
- \varnothing (diameter) > 3 mm: 0.5 Nm (4.43 lb-in)
- Insert the fiber in the amplifier:

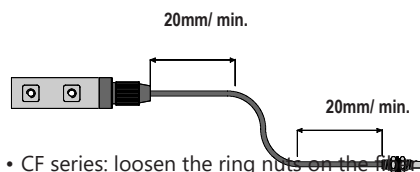

- CF series: loosen the ring nuts on the fiber carriers, insert the two optical fibers in their special seats, push down in order to overcome the resistance of the internal O-ring, then tighten the ring nuts securely.

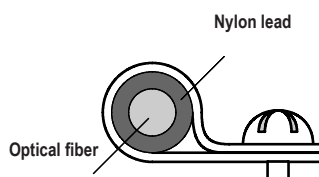

- OF Series: insert the special termination in the fiber-carrier seat of the MSF amplifier and tighten the ring nut securely.

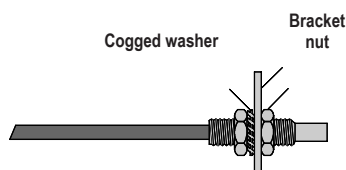

Please note:

It is important that the minimum radius of curvature be followed to avoid performance loss or breakage of bendable fiber terminations:

- Plastic fiber with core diameter 0.5 mm: Rmin = 5 mm
- Plastic fiber with core diameter 1 mm: min = 10 mm

Overvoltage protection

When an inductive load is switched off, the output voltage (when there is no protection circuit present) rises to such a high value that the output transistor may be destroyed. For this reason, our photo sensors feature a built-in Zener diode at the output, which limits the output voltage to a safe value (3-wire types). When connecting an inductive load with a current greater than 100 mA, and a switching frequency exceeding 10 Hz, the addition of a protective diode placed directly at the load terminal is recommended to limit the power loss of the built-in Zener diode.

Polarity reversal protection

All our photo sensors are protected against polarity reversal at all terminals. However, operation is only possible if the sensor is connected the right way.

Protection degree

For information on how to define your IP Rating, see the Appendix section of this desk reference.

Polarized reflective photoelectric sensor

This is a variant of the reflective photo sensor. A polarizing filter is placed in the emitter's optical path. A polarizing filter in the receiver is oriented at a right angle to the filter in the emitter. This results in the elimination of reflections from surfaces other than the reflector. The light from the reflector possesses a component that is strongly polarized in a perpendicular direction to the incident light. It becomes the only recognizable reflected-light source.

Photoelectric Sensor

Reflective photoelectric sensor

The emitter and receiver form part of the same unit. The optical beams are parallel. The emitter's luminous beam hits a reflector and is redirected toward the receiver. Detection occurs when the path of the beam is interrupted by the presence of an opaque object. Operating distance mainly depends on the quality of the reflector used and on the optical-beam angle.

Shock

In accordance with IEC 68-2-27:

- Pulse shape: half-sine
- Peak acceleration: 30g
- Pulse duration: 11ms

Short circuit protection

All DC devices feature a built-in protection circuit against short-circuits and overloads. Short-circuits between the output and both power supply terminals do not damage the switch and may be applied permanently. The same applies for overloads. During a short-circuit condition, the LEDs do not operate.

Status indicators

The LED indicators can be classified according to color:

Continuous green: Power on

Continuous yellow: Output on

Continuous red: Fault — When there is only one LED, it is usually red and indicates the output state.

Switching element functions

Dark operate

Allows current to flow when the path of the light beam does not reach receiver and will prevent flow when the path of the light beam does reach receiver.

Light operate

Allows current to flow when the path of the light beam reaches receiver and will prevent flow when the path of the light beam does not reach receiver.

Tightening torque

Over-tightening of the nuts can mechanically damage the photoelectric sensor. The following tightening torques should therefore not be exceeded:

M5 x 1 1.5 Nm

M18 x 1 20 Nm

M30 x 1.5 40 Nm

Through-beam photoelectric sensor

Emitter and receiver are housed in separate units and are installed adjacent to one another and carefully aligned. Detection occurs when the path of the beam is interrupted by the presence of an object.

Fork (or 'Slot') style photoelectric sensor

Fork sensors (sometimes referred to as "Slot" sensors) are a unique variety of through-beam sensors that incorporate both the emitter and receiver components in a u-shaped housing which simplifies mounting and cabling, and eliminates the need for alignment. Detection occurs when the path of the beam is interrupted by the presence of an object.

Types of output and load connections

3-wire NPN

There are two power wires and one output wire. The switching element is connected between the output wire and the negative terminal, and the load is connected between the output wire and the positive terminal. In the ON state, the current sinks from the load into the switching element.

3-wire PNP

There are two power wires and one output wire. The switching element is connected between the output wire and the positive terminal, and the load is connected between the output wire and the negative terminal. In the ON state, the current flows from the switching element into the load.

4-wire NPN or PNP

(Programmable output state)

There are two power wires, one N.O./N.C. selection input and one output wire. The output state is programmable, connecting the input wire to one of the power supply lines.

4-wire NPN or PNP

(Complementary outputs)

There are two power wires, one N.O. output and one N.C. output.

4-wire NPN and PNP

There are two power wires and the output type is wiring programmable. The NPN output is available by connecting the PNP terminal to the negative power supply line. The PNP output is available by connecting the NPN terminal to the positive power supply line.

2-wire AC

The two leads make up the switching element itself. In the ON state, with one terminal connected to the phase and the other to the load, current is drawn from the phase line and supplied to the load through the output terminal. The other load terminal is connected to the neutral line.

3-wire AC

These models have two power supply wires and one output. The switching element is connected between output terminal and phase line. In the ON state, current is drawn from the phase line and supplied to the load through the output terminal. The other load terminal is connected to the neutral line.

Vibration

In accordance with IEC 68-2-6:

- Frequency Range: 10-55 Hz
- Amplitude: 1 mm
- Sweep cycle duration: 5 min.
- Duration of endurance at 55 Hz: 30 min. in each of the three axis directions

Photoelectric Sensor

Field Device Examples - 3 Wire Connections

NPN (Sinking)
Field Device Example

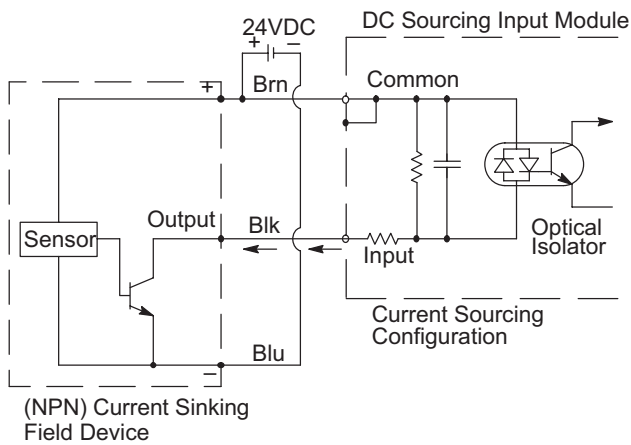

PNP (Sourcing)
Field Device Example

