

# 20W to 150W Touch-Safe PTC Heaters



06401.0-00

## Applications

Compact heater for the protection of electrical and electronic components in enclosures. Its design ensures great convection resulting in excellent heat dissipation. A touch-safe plastic cover provides for low surface temperatures on the side of the device. The practical push-in clamping terminal enables quick and easy electrical connection. The heaters are designed for continuous operation.

## Features

- DIN rail clips and pressure clamps for quick mounting
- Low surface temperature
- Wide voltage range
- Insulated plastic casing
- Loop-design heater body for optimal temperature distribution
- Shock- and vibration-proof



## 20W to 150W Touch-Safe PTC Heaters

Part Number	Price	Heating Capacity <sup>1</sup>	Operating Voltage	Max. current (inrush)	Recommended Fuse T	Weight (approx.)	Drawing Links
<a href="#">06401.0-00</a>	\$37.00	20W	120-240 VAC/VDC	2.0 A	4.0 A	7 oz [0.2 kg]	<a href="#">PDF</a>
<a href="#">06402.0-00</a>	\$41.50	30W					<a href="#">PDF</a>
<a href="#">06403.0-00</a>	\$57.00	40W		4.0 A	6.0 A	14.1 oz [0.4kg]	<a href="#">PDF</a>
<a href="#">06500.0-00</a>	\$59.00	50W					<a href="#">PDF</a>
<a href="#">06503.0-00</a>	\$88.00	100W		6.0 A	8.0 A	26.5 oz [0.75kg]	<a href="#">PDF</a>
<a href="#">06504.0-00</a>	\$113.00	150W		8.0 A	10.0 A		<a href="#">PDF</a>

1. At 68°F [20°C] ambient temperature

## 20W to 150W Touch-Safe PTC Heaters Specifications

<b>Heating Element</b>	PTC Resistor - Temperature limiting
<b>Connection</b>	(2) pressure clamps for stranded wire 0.5 - 1.5 mm <sup>2</sup> [20-16 AWG] (with wire end ferrule) and rigid wire 0.5 - 2.5 mm <sup>2</sup> [20-14 AWG]
<b>Housing</b>	Plastic according to UL94 V-0, black and white
<b>Mounting</b>	Clip for 35 mm DIN rail, EN 60715
<b>Mounting Position</b>	Vertical airflow (air outlet up, connection on bottom)
<b>Surface Temperature</b>	<+176 °F [ $<+80$ °C], except upper protective grille
<b>Operating/Storage Temperature</b>	-49 - 158°F [-45 - 70°C]
<b>Operating/Storage Humidity</b>	Max. 90% RH (non-condensing)
<b>Protection Class</b>	II (double insulated)
<b>Protection Type</b>	IP20
<b>Approvals*</b>	VDE, UL File No. E234324, EAC, DIN EN 60068-2-27:2010-02, DIN EN 60068-2-64:2009-04, in connection with DIN EN IEC 61373:2011-04, Cat. 1 B

\*To obtain the most current agency approval information, see the Agency Approval Checklist section on the specific part number's web page at [www.automationdirect.com](http://www.automationdirect.com)

## Wiring Diagram

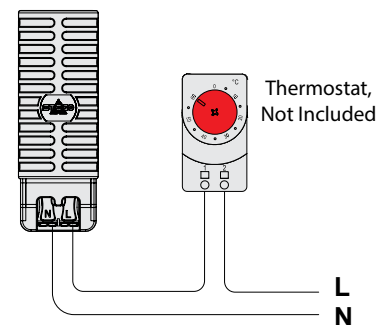

# 50W to 150W Touch-Safe PTC Heaters with Fixed Thermostat



06510.0-00

## Applications

Compact heater with PTC heating elements for heating enclosures. The heater prevents low temperature and thus condensation. Its aluminium profile is designed to achieve an optimized chimney effect, which ensures great convection resulting in excellent heat dissipation in the enclosure. The practical push-in clamping terminal enables quick and easy electrical connection. The heaters are designed for continuous operation.

## Features

- DIN rail clips and pressure clamps for quick mounting
- Low surface temperature
- Wide voltage range
- Insulated plastic casing
- Integrated Thermostat
- Loop-design heater body for optimal temperature distribution
- Shock- and vibration-proof



## 50W to 150W Touch-Safe PTC Heaters with Fixed Thermostat

Part Number	Price	Heating Capacity <sup>1</sup>	Operating Voltage	Max. current (inrush)	Recommended Fuse T	Switch-Off Temperature <sup>2</sup>	Switch-On Temperature <sup>2</sup>	Weight (approx.)	Drawing Links
<a href="#">06510.0-00</a>	\$71.00	50W	120-240 VAC/VDC	4.0 A	6.0 A	59°F [15°C]	41°F [5°C]	14.1 oz [0.4kg]	<a href="#">PDF</a>
<a href="#">06513.0-00</a>	\$97.00	100W		6.0 A	8.0 A	59°F [15°C]	41°F [5°C]	26.5 oz [0.75kg]	<a href="#">PDF</a>
<a href="#">06514.0-00</a>	\$124.00	150W		8.0 A	10.0 A	59°F [15°C]	41°F [5°C]		<a href="#">PDF</a>
<a href="#">06520.0-00</a>	\$71.00	50W		4.0 A	6.0 A	77°F [25°C]	59°F [15°C]	14.1 oz [0.4kg]	<a href="#">PDF</a>
<a href="#">06524.0-00</a>	\$124.00	150W		8.0 A	10.0 A	77°F [25°C]	59°F [15°C]	26.5 oz [0.75kg]	<a href="#">PDF</a>

1. At 68°F [20°C] ambient temperature
2. Tolerance of ±9°F [±5K]

## 50W to 150W Touch-Safe PTC Heaters with Fixed Thermostat Specifications

<b>Heating Element</b>	PTC Resistor - Temperature limiting
<b>Connection</b>	(2) pressure clamps for stranded wire 0.5 - 1.5 mm <sup>2</sup> [20-16 AWG] (with wire end ferrule) and rigid wire 0.5 - 2.5 mm <sup>2</sup> [20-14 AWG]
<b>Housing</b>	Plastic according to UL94 V-0, black and white
<b>Mounting</b>	Clip for 35mm DIN rail, EN 60715
<b>Mounting Position</b>	Vertical airflow (air outlet up, connection on bottom)
<b>Surface Temperature</b>	<+176 °F [ $\leq$ +80 °C], except upper protective grille
<b>Operating/Storage Temperature</b>	-49 - 158°F [-45 - 70°C]
<b>Operating/Storage Humidity</b>	Max. 90% RH (non-condensing)
<b>Protection Class</b>	II (double insulated)
<b>Protection Type</b>	IP20
<b>Approvals*</b>	VDE, UL File No. E234324, EAC, DIN EN 60068-2-27:2010-02, DIN EN 60068-2-64:2009-04, in connection with DIN EN IEC 61373:2011-04, Cat. 1 B

\*To obtain the most current agency approval information, see the Agency Approval Checklist section on the specific part number's web page at [www.automationdirect.com](http://www.automationdirect.com)

## Wiring Diagram

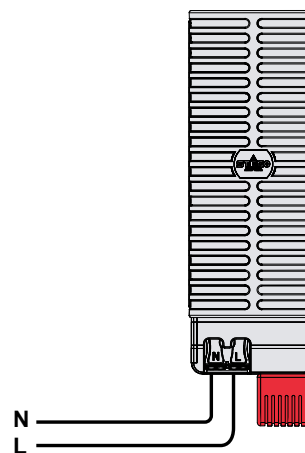

# 10W to 50W PTC Heaters



16400.9-00

## Applications

Compact heater with PTC heating elements for heating enclosures with electrical or electronic components. The heater prevents too-low temperatures and thus condensation harming the components. The design of the aluminium profile creates a chimney effect, which ensures even temperature distribution within the enclosure. The heaters are designed for continuous operation.

## Features

- DIN rail clips for quick mounting
- Wide voltage range
- Loop-design heater body for optimal temperature distribution
- Shock- and vibration-proof



10W to 50W PTC Heaters							
Part Number	Price	Heating Capacity <sup>1</sup>	Operating Voltage	Max. current (inrush)	Recommended Fuse T	Weight (approx.)	Drawing Links
<a href="#">16400.9-00</a>	\$35.50	10W	120-240 VAC/VDC	2.0 A	4.0 A	7 oz [0.2 kg]	<a href="#">PDF</a>
<a href="#">16401.9-00</a>	\$41.00	20W					<a href="#">PDF</a>
<a href="#">16402.9-00</a>	\$41.50	30W		<a href="#">PDF</a>			
<a href="#">16403.9-00</a>	\$55.00	40W		<a href="#">PDF</a>			
<a href="#">16404.9-00</a>	\$78.00	50W		4.0 A	6.0 A		<a href="#">PDF</a>

1. At 68°F [20°C] ambient temperature

10W to 50W PTC Heaters Specifications	
Heating Element	PTC Resistor - Temperature limiting
Connection	(3) 0.5 mm <sup>2</sup> x 300 mm stranded wire
Housing	Anodized Aluminum
Mounting	Clip for 35 mm DIN rail, EN 60715
Mounting Position	Vertical airflow (air outlet up, connection on bottom)
Operating/Storage Temperature	-49 – 158°F [-45 – 70°C]
Operating/Storage Humidity	Max. 90% RH (non-condensing)
Max Surface Temperature	320°F [170°C]
Protection Class	I (insulated)
Protection Type	IP20
Approvals*	CE, UL Recognized File No. E234324

\*To obtain the most current agency approval information, see the Agency Approval Checklist section on the specific part number's web page at [www.automationdirect.com](http://www.automationdirect.com)

## Wiring Diagram

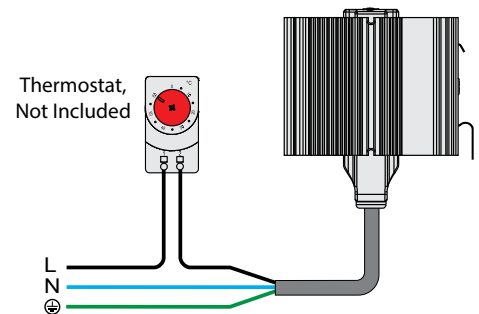

# 60W to 150W PTC Heaters



16501.0-00

## Applications

Compact heater with PTC heating elements for heating enclosures with electrical or electronic components. The heater prevents too-low temperatures and thus condensation harming the components. The design of the aluminium profile creates a chimney effect, which ensures great convection resulting in excellent heat dissipation within the enclosure. The practical push-in clamping terminal ensures quick and easy electrical connection. The heaters are designed for continuous operation.

## Features

- DIN rail clips and pressure clamps for quick mounting
- Wide voltage range
- Loop-design heater body for optimal temperature distribution



60W to 150W PTC Heaters							
Part Number	Price	Heating Capacity <sup>1</sup>	Operating Voltage	Max. current (inrush)	Recommended Fuse T	Weight (approx.)	Drawing Links
16501.0-00	\$78.00	60W	120-240 VAC/VDC	4.0 A	6.0 A	10.6 oz [0.3kg]	<a href="#">PDF</a>
16502.0-00	\$82.00	75W		6.0 A	8.0 A	17.6 oz [0.5kg]	<a href="#">PDF</a>
16503.0-00	\$89.00	100W		8.0 A	10.0 A		<a href="#">PDF</a>
16504.0-00	\$113.00	150W					<a href="#">PDF</a>

1. At 68°F [20°C] ambient temperature

60W to 150W PTC Heaters Specifications	
Heating Element	PTC Resistor - Temperature limiting
Connection	(3) pressure clamps for stranded wire 0.5 - 1.5 mm <sup>2</sup> [20-16 AWG] (with wire end ferrule) and rigid wire 0.5 - 2.5 mm <sup>2</sup> [20-14 AWG]
Housing	Body: Anodized Aluminum Connection Casing: plastic according to UL94 V-0, black
Mounting	Clip for 35 mm DIN rail, EN 60715
Mounting Position	Vertical airflow (air outlet up, connection on bottom)
Operating/Storage Temperature	-49 - 158°F [-45 - 70°C]
Operating/Storage Humidity	Max. 90% RH (non-condensing)
Max Surface Temperature	320°F [170°C]
Protection Class	I (insulated)
Protection Type	IP20
Approvals*	VDE, UL File No. 234324, EAC

\*To obtain the most current agency approval information, see the Agency Approval Checklist section on the specific part number's web page at [www.automationdirect.com](http://www.automationdirect.com)

## Wiring Diagram

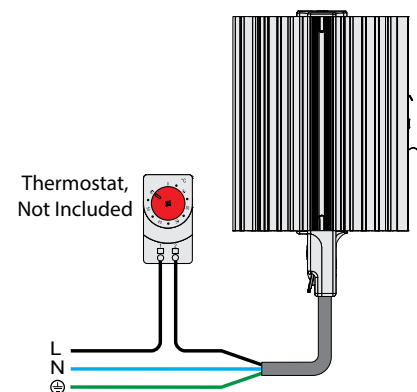

# Enclosure Heating and Heater Selection

## Why Heat an Enclosure?

Today's miniaturization of enclosure components results in high packing densities, which in turn results in higher temperatures within the enclosure. These high temperatures are harmful to electronic components. In response, cooling systems have become standard in many applications. However, just as critical and widely underestimated, are failures caused by the formation of moisture.

Under certain climatic conditions, moisture can build up not only in outdoor or poorly insulated enclosures, but also in highly protected and well-sealed enclosures.

## Moisture and Failure

Moisture, especially when combined with aggressive gases and dust, causes atmospheric corrosion and can result in the failure of components such as circuit breakers, busbars, relays, integrated circuit boards and transformers. The greatest danger lies in conditions where electronic equipment is exposed to relatively high air humidity or extreme variations in temperature, such as day-and-night operation or outdoor installation. Failure of components in such cases is usually caused by changing contact resistances, flashovers, creepage currents or reduced insulation properties.

## Eliminate Moisture

Moisture and corrosion will remain low if relative air humidity stays below 60%. However, relative humidity above 65% will significantly increase moisture and corrosion problems. This can be prevented by keeping the environment inside an enclosure at a temperature as little as 9°F (5°C) higher than that of the ambient air. Constant temperatures are a necessity to guarantee optimal operating conditions. Continuous temperature changes not only create condensation but they reduce the life expectancy of electronic components significantly. Electronic components can be protected by cooling during the day and heating at night.

## Thermal Management

Modern enclosure heaters are designed to protect against condensation. They heat the air inside enclosures, preventing water vapor from condensing on components while providing the greatest possible air circulation and low energy consumption.

Other heating element technology improvements include:

- Longer operating life
- Greater energy efficiencies
- Quick wiring options
- Easier mounting
- Fan heaters should be considered for larger enclosures to ensure that the entire enclosure is heated uniformly

## Heater Location

Ideally, most heaters will perform optimally when mounted near the bottom of an enclosure and used in conjunction with a control device, thermostat, and/or hygrostat. The control device may be a separate device, or it may be integral to the heater. With the controller located in an area of the cabinet that is representative of the average temperature or humidity requirement, the heater should then be placed in a position near the bottom of the enclosure. If a separate control device is used, the heater should not be located directly beneath the controller to ensure that the controller is not influenced by direct heat from the heater.

## Heater Calculation

Follow Steps 1-5 to determine the heating requirement of an enclosure (US units - left column, metric - right)

STEP 1: Determine the Surface Area (A) of your enclosure which is exposed to open air.

Enclosure Dimensions:

height = \_\_\_\_\_ feet \_\_\_\_\_ meters

width = \_\_\_\_\_ feet \_\_\_\_\_ meters

depth = \_\_\_\_\_ feet \_\_\_\_\_ meters

Choose Mounting Option from next page, and calculate the surface area as indicated

A = \_\_\_\_\_ ft<sup>2</sup> or \_\_\_\_\_ m<sup>2</sup>

STEP 2: Choose the Heat Transmission Coefficient (k) for your enclosure's material of construction.

painted steel = 0.511 W/(ft<sup>2</sup>K) 5.5 W/(m<sup>2</sup>K)

stainless steel = 0.344 W/(ft<sup>2</sup>K) 3.7 W/(m<sup>2</sup>K)

aluminum = 1.115 W/(ft<sup>2</sup>K) 12 W/(m<sup>2</sup>K)

plastic or insulated stainless = 0.325 W/(ft<sup>2</sup>K) 3.5 W/(m<sup>2</sup>K)

k = \_\_\_\_\_ W/(ft<sup>2</sup>K) or \_\_\_\_\_ W/(m<sup>2</sup>K)

STEP 3: Determine the Temperature Differential (ΔT).

A. Desired enclosure interior temp. = \_\_\_\_°F \_\_\_\_°C

B. Lowest ambient (outside) temp. = \_\_\_\_°F \_\_\_\_°C

Subtract B from A = Temp. diff. (ΔT) = \_\_\_\_°F \_\_\_\_°C

For these calculations, ΔT must be in° Kelvin (K). Therefore, divide ΔT (°F) by 1.8. ΔT = \_\_\_\_\_ K

STEP 4: Determine Heating Power (PV), if any (generated from existing components, i.e. transformer).

PV = \_\_\_\_\_ W or \_\_\_\_\_ W

STEP 5: Calculate the Required Heating Power (PH) for your enclosure based on the above values.

If enclosure is located inside:

PH = (A x k x ΔT) - PV = \_\_\_\_\_ W

If enclosure is located outside:

PH = 2 x (A x k x ΔT) - PV = \_\_\_\_\_ W

# Enclosure Mounting Types and Surface Area Calculations

## 1. Free-Standing

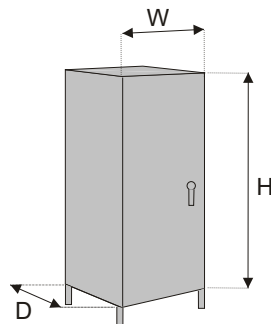

$$\text{Area (A)} = 1.8\text{ft}^2 [0.05\text{m}^2] (H \times W) + 1.8 (H \times D) + 1.8\text{ft}^2 [0.05\text{m}^2] (W \times D)$$

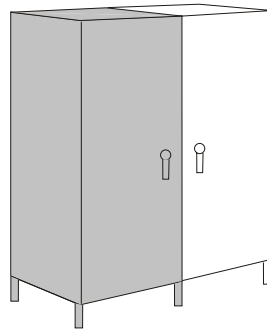

$$\text{Area (A)} = 1.8\text{ft}^2 [0.05\text{m}^2] (H \times W) + 1.4 (H \times D) + 1.8\text{ft}^2 [0.05\text{m}^2] (W \times D)$$

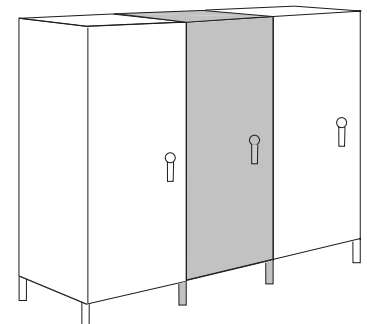

$$\text{Area (A)} = 1.8\text{ft}^2 [0.05\text{m}^2] (H \times W) + (H \times D) + 1.8\text{ft}^2 [0.05\text{m}^2] (W \times D)$$

## 2. Wall-Mounted

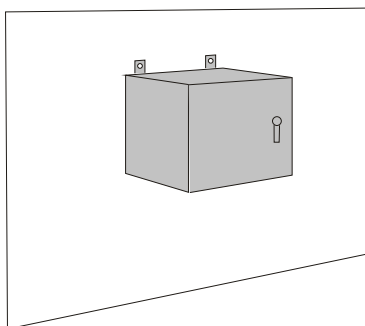

$$\text{Area (A)} = 1.4\text{ft}^2 [0.04\text{m}^2] (H \times W) + 1.8 (H \times D) + 1.8\text{ft}^2 [0.05\text{m}^2] (W \times D)$$

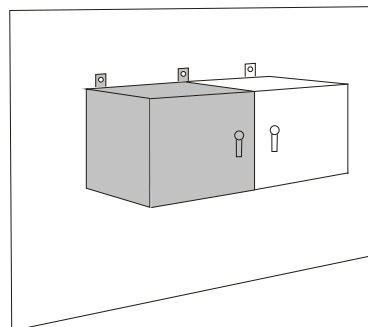

$$\text{Area (A)} = 1.4\text{ft}^2 [0.04\text{m}^2] (H \times W) + 1.4 (H \times D) + 1.8\text{ft}^2 [0.05\text{m}^2] (W \times D)$$

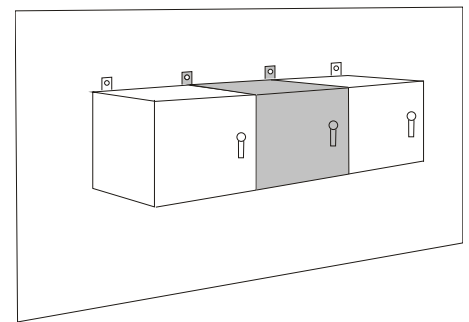

$$\text{Area (A)} = 1.4\text{ft}^2 [0.04\text{m}^2] (H \times W) + (H \times D) + 1.8\text{ft}^2 [0.05\text{m}^2] (W \times D)$$

## 3. Ground

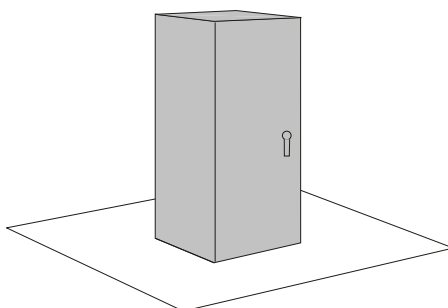

$$\text{Area (A)} = 1.8\text{ft}^2 [0.05\text{m}^2] (H \times W) + 1.8 (H \times D) + 1.4\text{ft}^2 [0.04\text{m}^2] (W \times D)$$

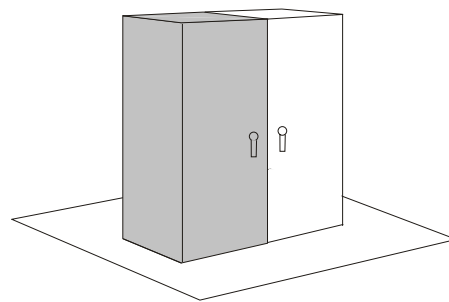

$$\text{Area (A)} = 1.8\text{ft}^2 [0.05\text{m}^2] (H \times W) + 1.4 (H \times D) + 1.4\text{ft}^2 [0.04\text{m}^2] (W \times D)$$

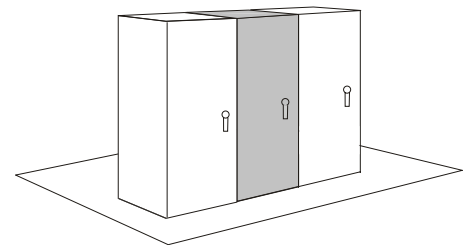

$$\text{Area (A)} = 1.8\text{ft}^2 [0.05\text{m}^2] (H \times W) + (H \times D) + 1.4\text{ft}^2 [0.04\text{m}^2] (W \times D)$$

## 4. Ground and Wall

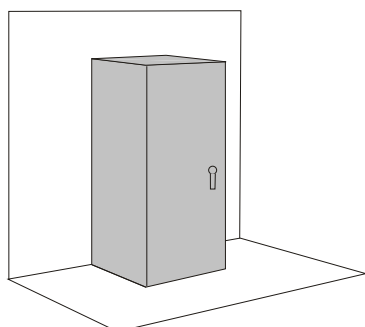

$$\text{Area (A)} = 1.4\text{ft}^2 [0.04\text{m}^2] (H \times W) + 1.8 (H \times D) + 1.4\text{ft}^2 [0.04\text{m}^2] (W \times D)$$

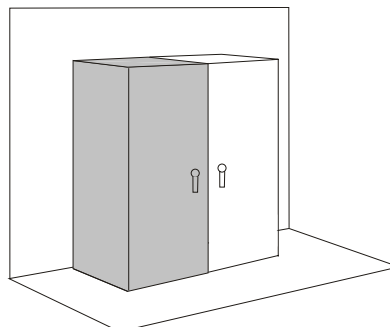

$$\text{Area (A)} = 1.4\text{ft}^2 [0.04\text{m}^2] (H \times W) + 1.4 (H \times D) + 1.4\text{ft}^2 [0.04\text{m}^2] (W \times D)$$

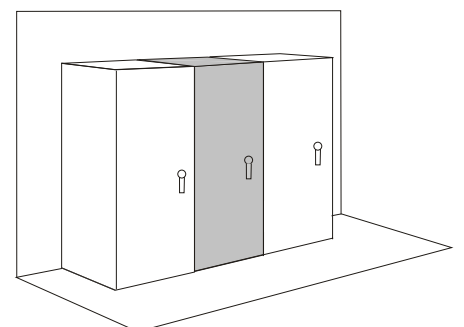

$$\text{Area (A)} = 1.4\text{ft}^2 [0.04\text{m}^2] (H \times W) + (H \times D) + 1.4\text{ft}^2 [0.04\text{m}^2] (W \times D)$$