



Stepping System Overview

High-performance microstepping drives with high-torque stepping motors

SureStep stepping systems provide simple and accurate control of position and speed. Pulses (or “step” and “direction” signals) from an AutomationDirect PLC or other indexer and motion controller are “translated” by the microstepping drive into precise movement of the stepping motor shaft. The SureStep stepping motors use 2-phase technology with 200 full steps per revolution or 1.8° per full step. Older type stepping motor drives, which operate stepping motors in full step mode, can result in stalling or lost motion due to potential problems with low speed mechanical vibration (usually between 100 to 200 RPM). To minimize this vibration problem, the SureStep microstepping drives use advanced microstepping technology to smooth the motor motion and stepping response. The SureStep family has options for open loop control (no encoder), position monitoring (external encoder feedback), and inclusive position verification (integrated motor/drives with internal encoder). Inclusive position verification provides for stall prevention and detection along with position completion after a temporary stall.

SureStep stepper drives support a wide range of selectable microstep resolutions, from 200 steps per revolution (full step) to 51,200 (full step ÷ 256) steps per revolution, depending on model.

The advanced drives can operate with traditional high-speed inputs, but can also be commanded via 0–5V analog input. They have an internal indexer that can accomplish point-to-point moves controlled via ASCII communication.

FREE configuration software!

SureMotion Pro software is available that makes setting parameters a snap for the advanced drives and advanced integrated motor/drives! SureMotion Pro replaces SureStep Pro configuration software. Download free from our website:

<https://support.automationdirect.com/products/surestep.html>

Standards and Agency Approvals

How fast can my system go?

Maximum Potential Speed Chart (rpm) *					
PLC		SureStep Drive Steps/Rev Selection **			
Model	Max Output (kHz)	400 Steps/Rev	1000 Steps/Rev	2000 Steps/Rev	10,000 Steps/Rev
DL05, DL105	7	1,050	420	210	42
DL06	10	1,500	600	300	60
H0/H2/H4/T1H-CTRIO	25	>2,500***	1,500	750	150
H2-CTRIO2	250	>2,500***			1,500
P2-HSO	1000	>2,500***			
P3-HSO	1000	>2,500***			
BRX	2000	>2,500***			

* These speeds are theoretical maximums. See torque curves of specific motors for their rpm limits.

** Full step (200 steps/rev) will allow higher top speed. Full stepping, however, can create vibration at low speed.

*** Typical stepper systems do not run faster than 2500 rpm.

Stepping Motor RPM = (A ÷ B) x (60 seconds/minute)

Where: A = PLC output frequency (pulses per second)
 B = microstepping resolution selection (steps/revolution)

Maximum RPM = $\frac{\text{Steps/Sec A}}{\text{Steps/Rev B}} \times \text{Sec/Min}$

Example 1: $1,500 = \frac{10,000}{400} \times 60$
 DL06 with 10 kHz Built-in Pulse Output

Example 2: $3,750 = \frac{25,000}{400} \times 60$
 Hx-CTRIO with 25 kHz Pulse Output

Stepping System Overview

Two or Four components to make a complete system

Choose an integrated motor/drive and power supply

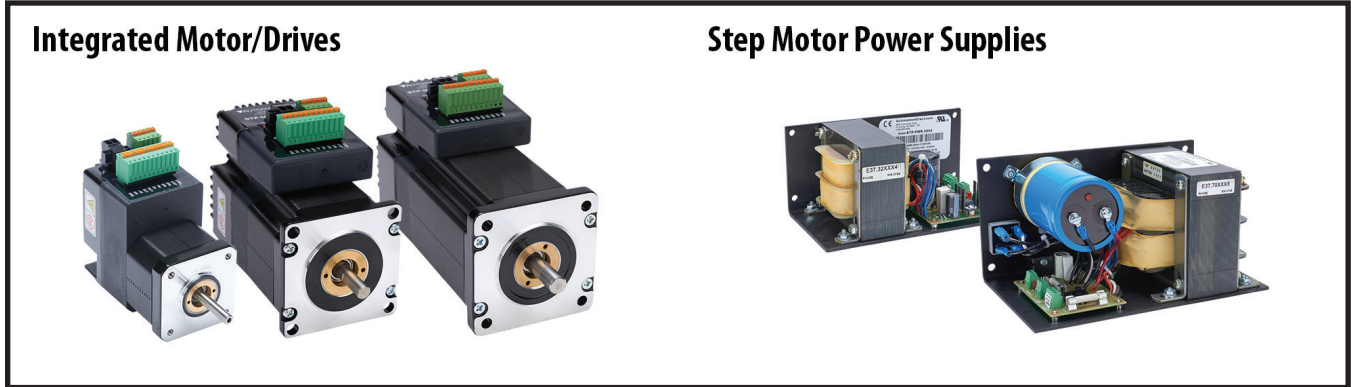

OR ...

Choose a separate drive, motor, motor extension cable and power supply

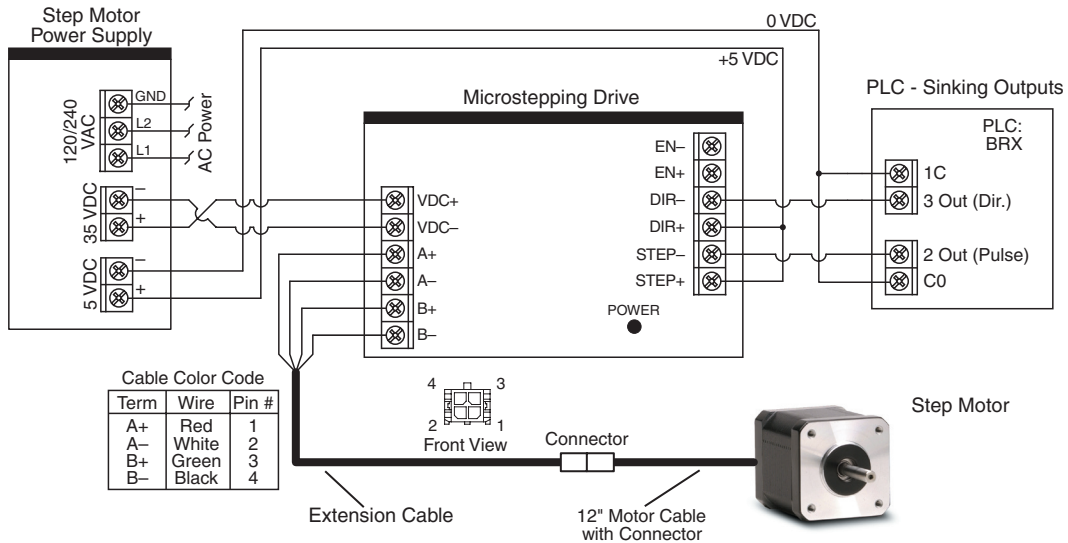
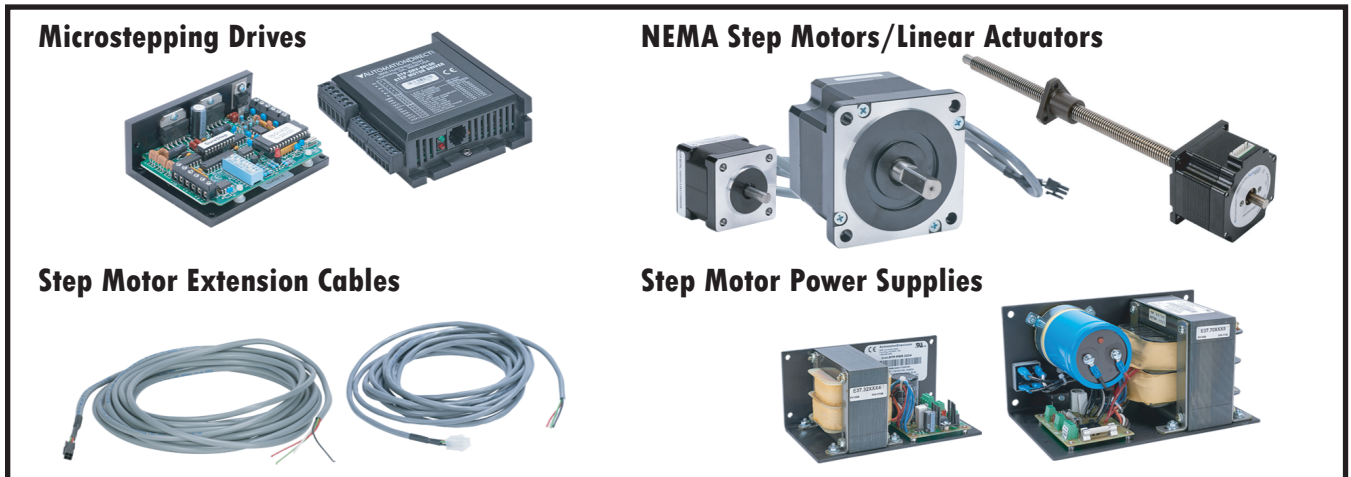



Stepping System Overview

NEMA frame stepping motors

The SureStep stepping family has a wide variety of high-torque motors to handle a wide range of automation applications such as woodworking, assembly, and test machines. The motors are available in both single-shaft and dual-shaft configurations, with or without an encoder. Our square frame or "high-torque" style stepping motors are the latest in bipolar technology, resulting in very high torque to volume ratios. We have NEMA 14, 17, 23, 34, and 42 size motors with holding torque ranging from 8 to 4532 oz-in. Wash down "W" motors (IP65) are also available. Optional 6, 10, or 20-foot extension cables with locking connectors are available to interface any of the stepping motors to the microstepping drive, except the NEMA 23 and NEMA 34 STP-MTRAC-x motors. Those MTRAC motors have an integrated 10-foot pigtail cable. The

extension cables can be easily cut to length, if desired. Integrated motor/drives and separate motors with an "E" in their part number include an encoder for position feedback. The MTRAC motors are designed to work with 115 or 230 VAC powered drives and can withstand high voltages. This allows higher torque, especially at higher speeds.

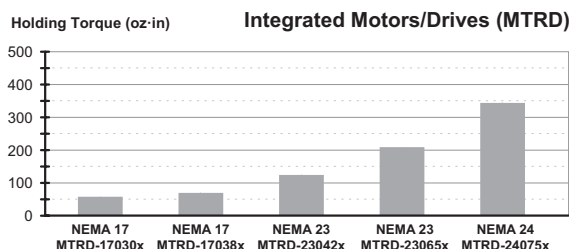
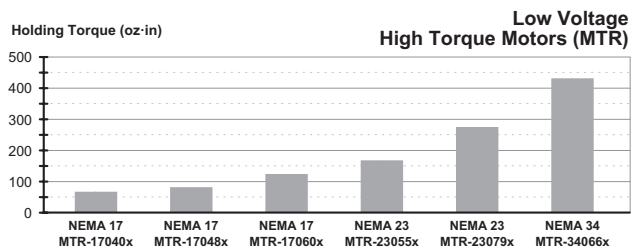
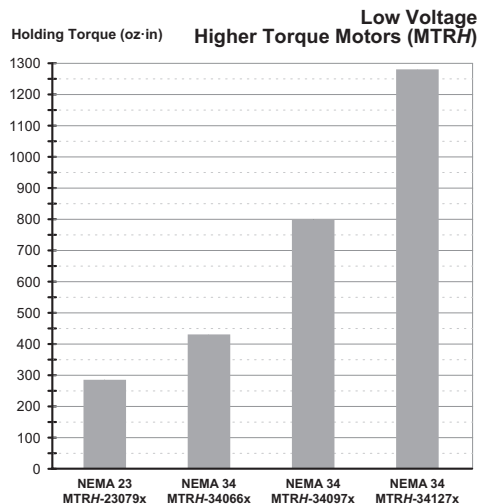
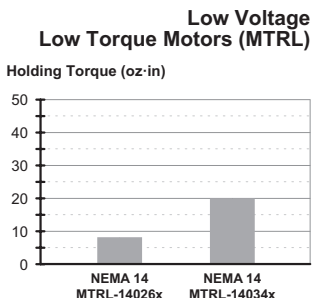

Note that the integrated motor/drive systems have a lower maximum torque due to heat constraints with the drive connected to the motor. For solutions requiring the highest torque, use the systems with our NEMA MTRH (low voltage, higher torque) or MTRAC (high voltage, high torque) motors.

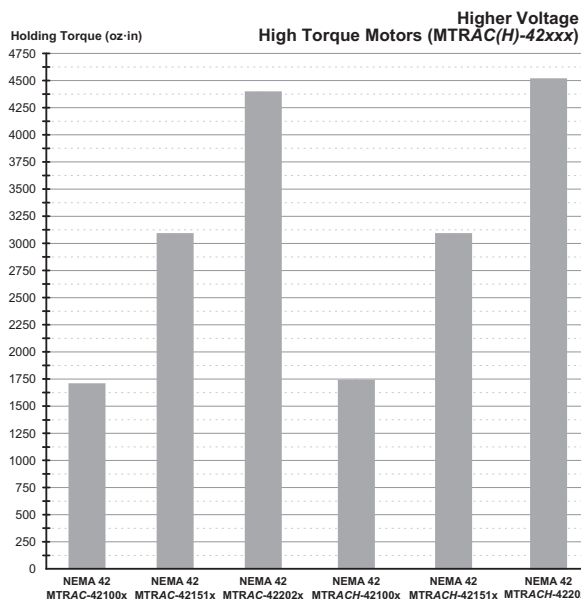
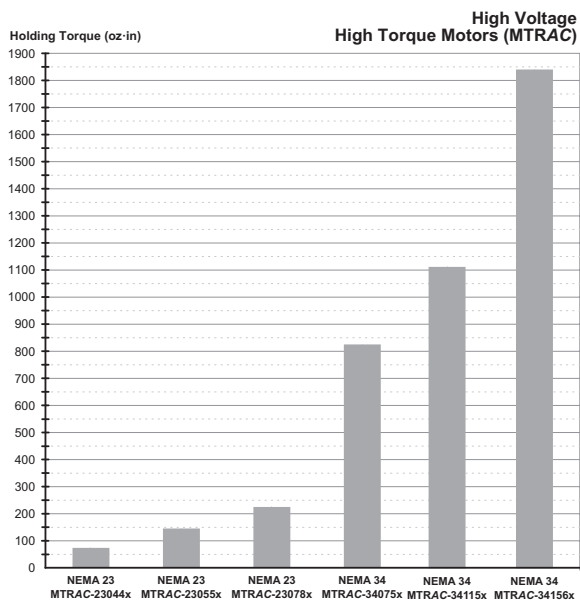

Note: While possessing similar holding torques, the MTRACH motors have much higher torque at high speeds than the MTRAC motors.



Stepping System Overview

NEMA frame stepping motors, continued

SureStep Stepper Linear Actuators combine all the great features of our stepper motors with a lead screw as the motor's shaft. NEMA 17 and 23 frame size motors are available with leads from 1.25mm/rev to 1inch/rev.

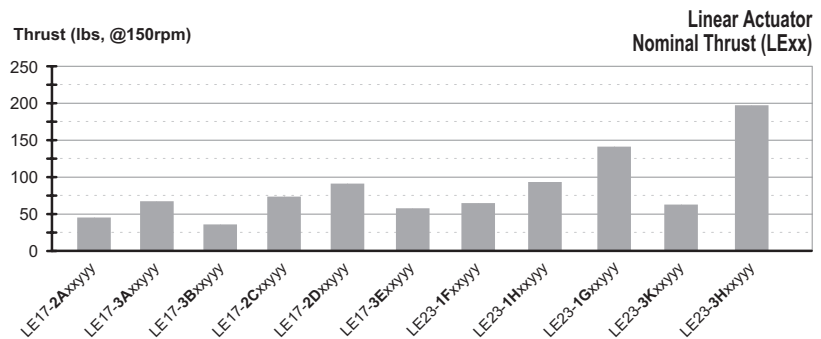

High-performance microstepping drives

SureStep microstepping drives

(STP-DRV-4035, -4830, -4845, -6575, & STP-MTRD-x)

- Standard high-speed pulse input (pulse and direction)
- On-board or removable screw terminals for easy hook-up
- Optically-isolated inputs ready for +5VDC logic from AutomationDirect PLCs, or 5–24 VDC (depending on model)
- No software or add-on resistors required for drive configuration; dipswitch and/or rotary-dial setup
- Dipswitch used for built-in self-test, microstep resolution selection, current level selection, and optional idle current reduction.
- Optional external encoder feedback for integrated models

SureStep high bus voltage microstepping drives

(STP-DRVAC-24025)

- Auto-setup measures motor parameters and configures motor current control and anti-resonance gain settings
- Uses universal AC input 90 to 240 VAC, AC input voltage must be selected by switch
- Switch selectable microstep resolution, 16 settings from 200 to 25600 steps/rev
- Switch configurable running current, anti-resonance, input signal filter, step smoothing filter, and self test
- Motor selection via 16-bit rotary switch

SureStep advanced microstepping drives

(STP-DRV-4850, STP-DRV-80100, & STP-MTRD-xR)

All the features of the standard high-performance drive, plus:

- Software configurable
- 200 - 51,200 microsteps (software selectable)
- High-speed pulse input (Quadrature, cw/ccw, pulse/direction)
- Analog velocity mode (0-5v or potentiometer)
- Internal indexer (point-to-point moves via ASCII command)
- AB quadrature/encoder following for all advanced models
- Advanced "E" integrated models contain a built-in encoder (encoder is not accessible and not available for signaling outside the drive)

Power supplies

- SureStep linear power supplies, 32V @ 4A, 48V @ 5A, 48V @ 10A, 70V @ 5A
- Input and output fuses included on power supplies
- Includes 5 VDC Logic supply for all low voltage signals
- Switching power supplies also available (12V, 24V, 48V)



Choose your SureStep System

1. Choose a motor

Determine the torque and speed required by your application. Then look at the motor speed-torque curves in the Motors and Standard Integrated and Advanced Integrated sections of this catalog chapter, or the thrust-speed curves for Linear Actuators. Choose a standalone or integrated motor or linear actuator that can run your application with plenty of speed and torque/thrust reserve (most stepper systems should have a 100% safety margin for torque/thrust). If encoder feedback is desired, be sure to choose a "D" or "E" model motor, or "ADJ" model actuator. If an IP65 rating is desired, choose a "W" motor (no IP65 linear actuator models available at this time).

Note: If you chose an Integrated motor/drive, you can skip to "Choose a Power Supply". If you chose an STP-MTRAC-23xxx or -34xxx motor, you are done. These motors use the STP-DRVAC-24025 drive, have no motor extension cable (10' leads on the motor), and require no power supply (the drive uses AC input power).

Note: The STP-MTRAC-42xxx motors cannot use the STP-DRVAC-24025 drive as it doesn't provide enough current.

NEMA 14, 17, 23, 34, and 42 mounting flanges

Variety of bipolar step motors to cover a wide range of applications

Holding torque ranges from 8 to 4532 oz-in

Single-shaft, Dual-shaft, IP65, high bus voltage, and encoder-mounted models available (Linear series does not have high bus voltage or IP65 models)

1-ft cable with locking connector on the end (not for linear actuators) (NEMA 23/34 MTRAC motors have 10' leads)



Square frame style produces high torque and achieves best torque-to-volume ratio

NEMA 17, 23 and 24 integrated motor/drives

NEMA 17 and 23 linear actuators

NEMA 42 MTRAC(H)

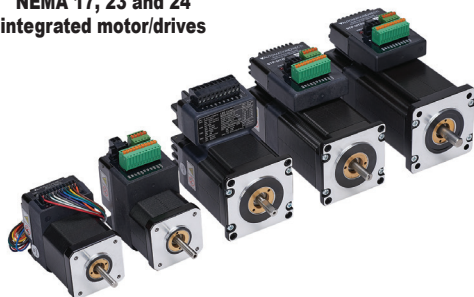

2. Choose a motor extension cable

[If you chose an Integrated motor/drive in Step 1, skip to "Choose a Power Supply"; an extension cable is not required.]

Our 6-, 10-, and 20-ft motor extension cables have a locking connector that mates up to the motor cable. The extension cables allow you to quickly connect the motor to the drive without having to splice wires or cut any cables.

Note: All NEMA 23/34 STP-MTRAC-x motors have integrated 10-foot cables and don't need an extension cable.

20-foot extension cable with locking connector



SureStep Motor / Cable Compatibility	
Motor	Cable
STP-LE17 series linear actuator	STP-LA-EXT17-xx
STP-LE23 series linear actuator	STP-LA-EXT23-xx
STP-MTR-xxxx	STP-EXT-0xx
STP-MTR-xxxxW	STP-EXTW-0xx
STP-MTRAC-23xxx/34xxx	None
STP-MTRAC-42xxx	STP-EXT42-0xx
STP-MTRACH-42xxx	STP-EXT42H-0xx
STP-MTRH-xxxx	STP-EXTH-0xx
STP-MTRH-xxxxW	STP-EXTHW-0xx
STP-MTRL-xxxx	STP-EXTL-0xx

3. Choose a drive

Note: If you chose an Integrated motor/drive in Step 1, skip to "Choose a Power Supply" . . . you have already chosen your drive. If you chose STP-MTRAC-23xxx or STP-MTRAC-34xxx, you are done - these motors use the STP-DRVAC-24025 drive and don't require an extension cable or DC power supply.

Note: The STP-MTRAC-42xxx motors cannot use the STP-DRVAC-24025 drive as it doesn't provide enough current.

The chart below is a quick selection guide. For a full list of features, check out the Technical Info later in this chapter. The requirements for what you will need from a drive are determined by your applications. Deciding whether you plan to operate the drive via high-speed pulses, analog control, encoder following, or communication commands is an important factor. The voltage supplied to the drive as determined by the speed torque curves is another important factor to consider when choosing a drive. If you need to select a drive based on RMS step motor phase current, please see the next page.

- Standard and Advanced Drives and Integrated Motor/Drives can accept high-speed pulse input control.
- Advanced Drives and some Integrated Motor/Drives can also accept serial communication control.
- STP-MTRAC-23xxx and -34xxx and STP-DRVAC motors and drives are designed for use with high voltages. These components are not designed to work at low voltages (12V, 32V, 48V, 70V).

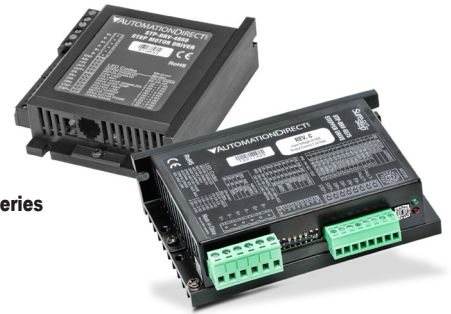

STP-DRV Series

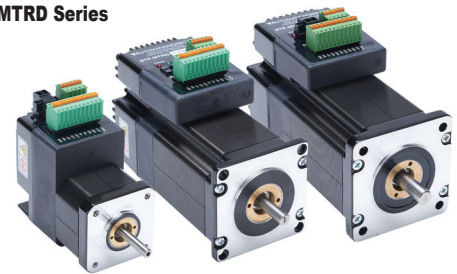

STP-MTRD Series

What you need	STP-DRV-4035	STP-DRV-4845	STP-DRV-4850	STP-DRV-6575	STP-DRV-80100	STP-MTRD-17x(E)	STP-MTRD-23x(E)	STP-MTRD-17xR(E)	STP-MTRD-23xR(E)	STP-MTRD-24xRV(E)
12V Speed-Torque Curve (from Step 1)	-	-	-	-	-	✓	✓	✓	✓	✓
32V Speed-Torque Curve (from Step 1)	✓	✓	✓	✓	✓	✓	✓	✓	✓	✓
48V Speed-Torque Curve (from Step 1)	-	✓	✓	✓	✓	-	✓	-	✓	✓
70V Speed-Torque Curve (from Step 1)	-	-	-	-	✓	-	✓	-	✓	✓
More than 3.5A/motor phase	-	✓	✓	✓	✓	-	-	-	-	-
More than 5A/motor phase ("H" motors)	-	-	-	✓	✓	-	-	-	-	-
Supply voltage	12-32	24-48	24-48	24-65	24-80	12-48	12-70	12-48	12-70	12-70
Digital Input Voltage	5V (12V*, 24V*)	5-24V	5V (12V*, 24V*)	5-24V	5V (12V*, 24V*)	5-24V	5-24V	5-24V	5-24V	5-24V
Internal Indexing (Drive can move from point A to point B with a serial communication command)	-	-	✓	-	✓	-	-	✓	✓	✓
High-speed pulse input	✓	✓	✓	✓	✓	✓	✓	✓	✓	✓
Analog Velocity input	-	-	✓	-	✓	-	-	✓	✓	✓
Position Verification (internal encoder)	-	-	-	-	-	-	-	E models only	E models only	E models only
External encoder	-	-	-	-	-	E models only	E models only	-	-	-
RS-232 communication (ASCII)	-	-	✓	-	✓	-	-	-	-	-
RS-485 communication (ASCII)	-	-	-	-	-	-	-	✓	✓	✓
Variable I/O (I/O can be either a digital input or digital output)	-	-	-	-	-	-	-	-	-	✓

* External dropping resistor required for 12V and 24V I/O use. See Product Data Sheet for wiring details and resistor values.



Choose your SureStep System

3a. Using RMS Step Motor Phase Current to Select an Appropriate Stepper Drive Rated in Peak Phase Current

$$(\text{Drive Amps})_{\text{peak}} = 1.2 \times (\text{Motor Amps})_{\text{RMS}}$$

Generic stepper drives usually have output current specified in peak phase current while stepper motors will have their phase current specified in RMS phase current. This can cause sub-optimal drive to motor pairing unless this is understood. There is no need to understand this difference if you are selecting a system that uses the SureStep drives that are tuned for specific SureStep motors. These drives will have a rotary switch setting (STP-DRV-6575 and STP-DRVAC-24025) or a motor selection in the SureMotion Pro software (STP-DRV-4850 and STP-DRV-80100). These drives when properly paired with a SureStep motor will output 1.2 times the motor rated phase current.

When choosing a drive that only has current selections instead of motor specific selections you will want to select a peak current that is 1.2 times the motor's listed RMS current. The true peak drive current value would be 1.4 times the RMS motor value but this amount of current will cause a lot of motor heating and the torque at higher speeds will actually suffer with due to higher back electro-magnetic force caused by the inductive field of the coils changing polarity quickly.

Example of a SureStep matched stepper system

To use an STP-MTR-23055 motor with a STP-DRV-6575 drive, the drive's rotary switch should be positioned to selection 9 (STP-MTR-23055x). The STP-MTR-23055 has a phase current of 2.8 A (RMS), so the drive will actually output $1.2 \times 2.8 \text{ A (RMS)} = 3.36 \text{ A (peak)}$. You do not need to calculate peak or RMS current with a pre-configured SureStep motor and drive system.

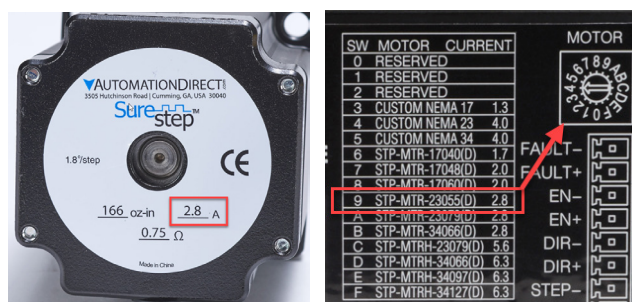

Matched stepper system

Example of an adjustable current stepper drive

To use an STP-MTR-23055 motor with a STP-DRV-4845 drive, you should calculate the correct phase current setting for the drive. The motor phase current is 2.8 A (RMS).

- If you do not understand peak vs RMS current, you would select phase current position #8, the 2.8 A selection on the drive (blue box). This setting will work (and the motor will run very cool) but will provide slightly less than the motor's rated torque.
- If a true peak current value is selected ($1.4 \times 2.8 \text{ A} = 3.92 \text{ A}$) then the rotary switch selection would be set to the C position (red box). This will cause excessive motor heating and a lack of performance at higher speeds.
- The optimal phase current selection for stepper motors is 1.2 times the motor RMS phase current ($1.2 \times 2.8 \text{ A (RMS)} = 3.36 \text{ A (peak)}$). This will be the rotary switch selection A (green box)

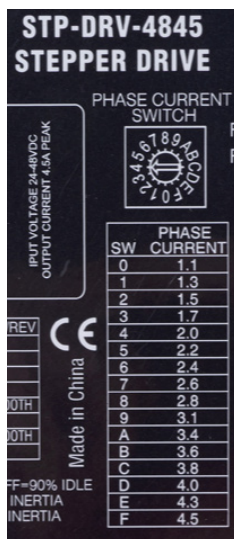

STP-DRV-4845 Motor Selection Table (A/Phase)(Peak of Sine A)			
Rotary Switch Position	SW1 & SW2 @100%	SW1 & SW2 @90%	SW1 & SW2 @80%
0	1.1	1.0	0.9
1	1.3	1.2	1.0
2	1.5	1.4	1.2
3	1.7	1.5	1.4
4	2.0	1.8	1.6
5	2.2	2.0	1.8
6	2.4	2.2	1.9
7	2.6	2.3	2.1
8	2.8	2.5	2.2
9	3.1	2.8	2.5
A	3.4	3.1	2.7
B	3.6	3.2	2.9
C	3.8	3.4	3.0
D	4.0	3.6	3.2
E	4.3	3.9	3.4
F	4.5	4.1	3.6

Matching an adjustable stepper drive with any step motor



Choose your SureStep System

4. Choose a power supply

Since all low voltage SureStep (non-integrated) motors can operate at 32V, 48V, and 70V, the selection of a power supply is dependent on the selected speed-torque curve of the motor and on the selection of drive. If using an integrated motor/drive, then the power supply is dictated by the specifications of the integrated product. If using an STP-MTRAC-23xxx or -34xxx drive, no DC power supply is needed since the drive is powered directly from 115 to 230 VAC. Choose a power supply that matches the desired speed-

torque curve and stays within the voltage limit of the selected drive. Each SureStep linear power supply has incoming AC and outgoing DC fusing. The linear supplies have an electronic overload protected 5V supply for all your logic needs. Stepper applications without large fluctuations in load, without aggressive deceleration, and without regeneration (where the load pushes the motor) can often use a switching power supply instead.

Permissible Drive/Power Supply Combinations

DC Powered Drive	Linear Power Supply				Switching Power Supply		
	<i>STP-PWR-3204</i>	<i>STP-PWR-4805</i>	<i>STP-PWR-4810</i>	<i>STP-PWR-7005</i>	<i>PSB12-xxxS</i>	<i>PSB24-xxxS</i>	<i>PSB48-xxxS</i>
STP-DRV-4830 12-48 VDC input (53V max)	√	√	√	-	√	√	√
STP-DRV-4845 24-48 VDC input (60V max)	√	√	√	-	-	√	√
STP-DRV-4850 24-48 VDC input (53V max)	√	√	√	-	-	√	√
STP-DRV-6575 24-65 VDC input (85V max)	√	√	√	-	-	√	√
STP-DRV-80100 24-80 VDC input (88V max)	√	√	√	√	-	√	√
STP-MTRD-17 series 12-48 VDC input (55V max)	√	√	√	-	√	√	√
STP-MTRD-23, -24 series 12-70 VDC input (75V max)	√	√	√	√	√	√	√
Supply current calculation	For systems that use multiple steppers and only one power supply, the power supply current must be at least the sum of 2/3rds of the combined motor currents: $I(ps) \geq 2/3 \times (I_{motor1} + I_{motor2} + I_{motor3} + \dots)$						

Linear Power Supply

120 or 240 VAC, 50/60 Hz power input (switch selectable)

Screw terminal AC input and DC output connections

32V, 48V and 70V linear supplies

Power ON LEDs

unregulated linear supplies perfect for stepper systems

Input and output fusing included



5 VDC ±5% at 500 mA regulated logic power

Switching Power Supply

85-264 VAC (DC input range 120-375 VDC)

Rugged plastic or aluminum housings with integral 35mm DIN rail mounting adapters

Adjustable output voltage



Output voltage status LED

DC Output Overload and Short-Circuit Protected

Note: For detailed information on the switching power supplies, please see: <https://cdn.automationdirect.com/static/specs/rhinopsbc1d2.pdf>

Linear Actuators

SureStep® Linear Actuators

SureStep Linear Actuators consist of Surestep NEMA 17 or NEMA 23 stepper motors that incorporate a stainless steel lead screw as the rotor. This translates the motor's torque into linear thrust. No maintenance, non-lubricated PTFE-infused polymer lead screw nuts allow for a long life. Triangular nuts come standard on the actuators. Replacement triangular nuts and spare round nuts are available. The motors in these actuators are from the same family of motors as the other SureStep stepper motors. The linear actuators come in 6, 9, and 12 inch lengths. A 1-ft motor power cable ships with the actuator and plugs into the motor's integrated connectors. Longer motor power cables are available in 6, 10, and 20 foot lengths.

Linear actuators ending in "ANN" are the most cost effective. Actuators ending in "ADJ" have a journal machined at the end of the screw to accept a bearing for mounting. There is also a groove cut into the journal for a retaining clip. See the SureStep User Manual for more details and bearing/clip specifications. The "ADJ" actuators also feature a rear motor shaft and encoder mounting holes pre-drilled and tapped. See our line of CUI stepper motor encoders for a complete line of available encoders that can mount onto the linear actuators.



ADJ series journal end

SureStep Series Part Numbers – Linear Actuators											
Linear Actuator	Price	Screw End Machining	NEMA Frame Size	Lead Screw Length	Lead Screw Material	Lead (in/rev or mm/rev)	Linear Travel (per 1.8° rotation)		Nominal Thrust (lbs)	Motor Weight (lbs)	Drawing
							in/step	mm/step			
STP-LE17-2A06ANN	\$104.00	None	17	6"	Stainless Steel	0.25"	0.00125	0.03175	45	0.7	PDF
STP-LE17-2C06ANN	\$105.00					3mm	0.00059	0.015	73	0.7	PDF
STP-LE17-2D06ANN	\$107.00					1.25 mm	0.00025	0.00625	87	0.8	PDF
STP-LE17-3A06ANN	\$118.00					0.25"	0.00125	0.03175	69	0.9	PDF
STP-LE17-3B06ANN	\$118.00					0.5"	0.0025	0.0635	38	0.9	PDF
STP-LE17-3E06ANN	\$116.00					8mm	0.0016	0.04	55	1.0	PDF
STP-LE17-2A06ADJ	\$121.00	Journal and groove	17	6"	Stainless Steel	0.25"	0.00125	0.03175	45	0.7	PDF
STP-LE17-2C06ADJ	\$119.00					3mm	0.00059	0.015	73	0.7	PDF
STP-LE17-2D06ADJ	\$120.00					1.25 mm	0.00025	0.00625	87	0.8	PDF
STP-LE17-3A06ADJ	\$131.00					0.25"	0.00125	0.03175	69	0.9	PDF
STP-LE17-3B06ADJ	\$132.00					0.5"	0.0025	0.0635	38	0.9	PDF
STP-LE17-3E06ADJ	\$130.00					8mm	0.0016	0.04	55	1.0	PDF
STP-LE23-1F06ANN	\$140.00	None	23	6"	Stainless Steel	10.5 mm	0.0021	0.0525	63	1.4	PDF
STP-LE23-1H06ANN	\$153.00					6mm	0.0012	0.03	87	1.4	PDF
STP-LE23-1G06ANN	\$154.00					2mm	0.0004	0.01	137	1.4	PDF
STP-LE23-3K06ANN	\$202.00					1"	0.005	0.127	62	2.7	PDF
STP-LE23-3H06ANN	\$189.00					6mm	0.0012	0.03	193	2.7	PDF
STP-LE23-1F06ADJ	\$163.00					10.5 mm	0.0021	0.0525	63	1.4	PDF
STP-LE23-1H06ADJ	\$177.00	Journal and groove	23	6"	Stainless Steel	6mm	0.0012	0.03	87	1.4	PDF
STP-LE23-1G06ADJ	\$179.00					2mm	0.0004	0.01	137	1.4	PDF
STP-LE23-3K06ADJ	\$215.00					1"	0.005	0.127	62	2.7	PDF
STP-LE23-3H06ADJ	\$204.00					6mm	0.0012	0.03	193	2.7	PDF

Motors listing continued on next page





Linear Actuators

SureStep® Linear Actuators



STP-LE23-1G09ADJ

SureStep Series Part Numbers – Linear Actuators (Cont'd)															
Linear Actuators	Price	Screw End Machining	NEMA Frame Size	Lead Screw Length	Lead Screw Material	Lead (in/rev or mm/rev)	Linear Travel (per 1.8° rot.)		Nominal Thrust (lbs)	Motor Weight (lbs)	Drawing				
							in/step	mm/step							
STP-LE17-2A09ANN	\$110.00	None	17	9"	Stainless Steel	0.25"	0.00125	0.03175	45	0.8	PDF				
STP-LE17-2C09ANN	\$107.00					3mm	0.00059	0.015	73	0.8	PDF				
STP-LE17-2D09ANN	\$109.00					1.25 mm	0.00025	0.00625	87	0.9	PDF				
STP-LE17-3A09ANN	\$121.00					0.25"	0.00125	0.03175	69	1.1	PDF				
STP-LE17-3B09ANN	\$121.00					0.5"	0.0025	0.0635	38	1.1	PDF				
STP-LE17-3E09ANN	\$119.00					8mm	0.0016	0.04	55	1.2	PDF				
STP-LE17-2A09ADJ	\$125.00					Journal and groove	17	9"	Stainless Steel	0.25"	0.00125	0.03175	45	0.8	PDF
STP-LE17-2C09ADJ	\$120.00									3mm	0.00059	0.015	73	0.8	PDF
STP-LE17-2D09ADJ	\$124.00									1.25 mm	0.00025	0.00625	87	0.9	PDF
STP-LE17-3A09ADJ	\$134.00									0.25"	0.00125	0.03175	69	1.1	PDF
STP-LE17-3B09ADJ	\$134.00									0.5"	0.0025	0.0635	38	1.1	PDF
STP-LE17-3E09ADJ	\$133.00									8mm	0.0016	0.04	55	1.2	PDF
STP-LE23-1F09ANN	\$155.00	None	23	9"	Stainless Steel	10.5 mm	0.0021	0.0525	63	1.6	PDF				
STP-LE23-1H09ANN	\$167.00					6mm	0.0012	0.03	87	1.7	PDF				
STP-LE23-1G09ANN	\$170.00					2mm	0.0004	0.01	137	1.7	PDF				
STP-LE23-3K09ANN	\$211.00					1"	0.005	0.127	62	3.0	PDF				
STP-LE23-3H09ANN	\$194.00					6mm	0.0012	0.03	193	3.0	PDF				
STP-LE23-1F09ADJ	\$167.00					Journal and groove	23	9"	Stainless Steel	10.5 mm	0.0021	0.0525	63	1.6	PDF
STP-LE23-1H09ADJ	\$182.00	6mm	0.0012	0.03	87					1.7	PDF				
STP-LE23-1G09ADJ	\$184.00	2mm	0.0004	0.01	137					1.7	PDF				
STP-LE23-3K09ADJ	\$214.00	1"	0.005	0.127	62					3.0	PDF				
STP-LE23-3H09ADJ	\$209.00	6mm	0.0012	0.03	193					3.0	PDF				
STP-LE17-2A12ANN	\$113.00	None	17	12"	Stainless Steel					0.25"	0.00125	0.03175	45	0.9	PDF
STP-LE17-2C12ANN	\$109.00					3mm	0.00059	0.015	73	0.9	PDF				
STP-LE17-2D12ANN	\$111.00					1.25 mm	0.00025	0.00625	87	1.0	PDF				
STP-LE17-3A12ANN	\$125.00					0.25"	0.00125	0.03175	69	1.3	PDF				
STP-LE17-3B12ANN	\$125.00					0.5"	0.0025	0.0635	38	1.3	PDF				
STP-LE17-3E12ANN	\$123.00					8mm	0.0016	0.04	55	1.4	PDF				
STP-LE17-2A12ADJ	\$128.00					Journal and groove	17	12"	Stainless Steel	0.25"	0.00125	0.03175	45	0.9	PDF
STP-LE17-2C12ADJ	\$123.00									3mm	0.00059	0.015	73	0.9	PDF
STP-LE17-2D12ADJ	\$126.00									1.25 mm	0.00025	0.00625	87	1.0	PDF
STP-LE17-3A12ADJ	\$137.00									0.25"	0.00125	0.03175	69	1.3	PDF
STP-LE17-3B12ADJ	\$137.00									0.5"	0.0025	0.0635	38	1.3	PDF
STP-LE17-3E12ADJ	\$135.00									8mm	0.0016	0.04	55	1.4	PDF
STP-LE23-1F12ANN	\$158.00	None	23	12"	Stainless Steel	10.5 mm	0.0021	0.0525	63	1.8	PDF				
STP-LE23-1H12ANN	\$173.00					6mm	0.0012	0.03	87	2.0	PDF				
STP-LE23-1G12ANN	\$177.00					2mm	0.0004	0.01	137	2.0	PDF				
STP-LE23-3K12ANN	\$220.00					1"	0.005	0.127	62	3.3	PDF				
STP-LE23-3H12ANN	\$200.00					6mm	0.0012	0.03	193	3.3	PDF				
STP-LE23-1F12ADJ	\$172.00					Journal and groove	23	12"	Stainless Steel	10.5 mm	0.0021	0.0525	63	1.8	PDF
STP-LE23-1H12ADJ	\$186.00	6mm	0.0012	0.03	87					2.0	PDF				
STP-LE23-1G12ADJ	\$189.00	2mm	0.0004	0.01	137					2.0	PDF				
STP-LE23-3K12ADJ	\$218.00	1"	0.005	0.127	62					3.3	PDF				
STP-LE23-3H12ADJ	\$213.00	6mm	0.0012	0.03	193					3.3	PDF				

SureStep® Linear Actuators Specifications

SureStep Series Specifications – NEMA 17 Linear Actuators						
Linear Actuator Motors	STP-LE17-2Axxxx	STP-LE17-2Cxxxx	STP-LE17-2Dxxxx	STP-LE17-3Axxxx	STP-LE17-3Bxxxx	STP-LE17-3Exxxx
NEMA Frame Size	17					
Phases	2					
Rated Current	2A					
Phase Resistance	1.04 Ω ± 10% (@20°C)			1.25 Ω ± 15% (@20°C)		
Phase Inductance	2.5 mH ± 20% (1kHz 1V rms)			2.8 mH ± 20% (1kHz 1V rms)		
Rotor Inertia	57 g·cm ²			82 g·cm ²		
Rotational Shaft Holding Torque	0.46 N·m (65.14 oz-in)			0.63 N·m (89.21 oz-in)		
No. of Motor Stacks	2			3		
Motor Length	39.8 mm			48.3 mm		
Lead Screw Material	SUS303Cu (cold-finished stainless steel)					
Nut Material	TECAFORM AD AF (PTFE-infused polymer)					
Lead	0.25"/rev	3 mm/rev	1.25 mm/rev	0.25"/rev	0.5"/rev	8mm/rev
Linear Travel/Step (per 1.8° rotation)	0.00125 in/step	0.015 mm/step	0.00625 mm/step	0.00125 in/step	0.0025 in/step	0.04 mm/step
Linear Speed (@150rpm)¹	0.625 in/sec	7.5 mm/sec	3.125 mm/sec	0.625 in/sec	1.25 in/sec	20 mm/sec
Thrust (@150rpm)	45lbs	73lbs	87lbs	69lbs	38lbs	55lbs
Load Limit (lbs)²	75	75	80	75	75	80
Radial Deflection (Max)³	6" lead screw: 0.015" 9" lead screw: 0.0225" 12" lead screw 0.03"					
Ambient Operating Temperature	-20-50°C					
Insulation Class	B (130°C)					
Screw Diameter	0.25"	6.5 mm	8mm	0.25"	0.25"	8mm
Agency Approvals	CE					

1 To determine your linear speed as it relates to RPM use the following formula: Linear Speed = RPM x (Lead/60 sec)
2 The load limit indicates max load before the nut begins to have its lifespan negatively impacted, not what the linear actuator can move.
3 Calculated deflection is the deflection value measured at the end of the lead screw.
Note: For dual-shaft motors (STP-LExx-xxxxADJ series) the sum of the front and rear torque loads, radial loads, and thrust loads must not exceed the applicable torque, radial and thrust load ratings of the motor.

SureStep® Linear Actuators Specifications

SureStep Series Specifications – NEMA 23 Linear Actuators					
Linear Actuator Motors	STP-LE23-1Fxyyy	STP-LE23-1Hxyyy	STP-LE23-1Gxyyy	STP-LE23-3Kxyyy	STP-LE23-3Hxyyy
NEMA Frame Size	23				
Phases	2				
Rated Current	2.1 A			3A	
Phase Resistance	1.6 Ω ± 10% (@20°C)			1.1 Ω ± 10% (@20°C)	
Phase Inductance	3.9 mH ± 20% (1kHz 1V rms)			5.0 mH ± 20% (1kHz 1V rms)	
Rotor Inertia	180 g·cm ²			460 g·cm ²	
Rotational Shaft Holding Torque	0.9 N·m (127.45 oz-in)			2.3 N·m (325.70 oz-in)	
No. of Motor Stacks	1			3	
Motor Length	45mm			79mm	
Lead Screw Material	SUS303Cu (cold-finished stainless steel)				
Nut Material	TECAFORM AD AF (PTFE-infused polymer)				
Lead	10.5 mm/rev	6mm/rev	2mm/rev	1"/rev	6mm/rev
Linear Travel/Step (per 1.8° rotation)	0.0525 mm/step	0.03 mm/step	0.01 mm/step	0.005 in/step	0.03 mm/step
Linear Speed (@150rpm)¹	26.25 mm/sec	15 mm/sec	5 mm/sec	2.5 in/sec	15 mm/sec
Thrust (@150rpm)	63lbs	87lbs	137 lbs	62 lbs	193 lbs
Load Limit (lbs)²	100	175	175	175	175
Radial Deflection (Max)³	6" lead screw: 0.015" 9" lead screw: 0.0225" 12" lead screw 0.03"				
Ambient Operating Temperature	-20-50°C				
Insulation Class	B (130°C)				
Screw Diameter	10mm	12mm	12mm	0.5"	12mm
Agency Approvals	CE				

¹ To determine your linear speed as it relates to RPM use the following formula: Linear Speed = RPM x (Lead/60 sec)

² The load limit indicates max load before the nut begins to have its lifespan negatively impacted, not what the linear actuator can move.

³ Calculated deflection is the deflection value measured at the end of the lead screw.

Note: For dual-shaft motors (STP-LExx-xxxxADJ series) the sum of the front and rear torque loads, radial loads, and thrust loads must not exceed the applicable torque, radial and thrust load ratings of the motor.

SureStep® Linear Actuator Thrust vs. Speed Charts

The charts below detail the thrust output by the motor depending on the linear speed of the motor. The highest thrust is achievable at the lowest speeds. Note that for some motors, the output thrust (solid lines) can exceed the load tolerance (horizontal dashed lines) of the nut on the shaft. **Allow sufficient time to accelerate the load and size the step motor with a 100% thrust safety factor (i.e.: design the system using a maximum of 50% of the motor's thrust).**

STP-LE17-2xxxx NEMA 17 Step Motor Linear Actuators (Double-stack motors)

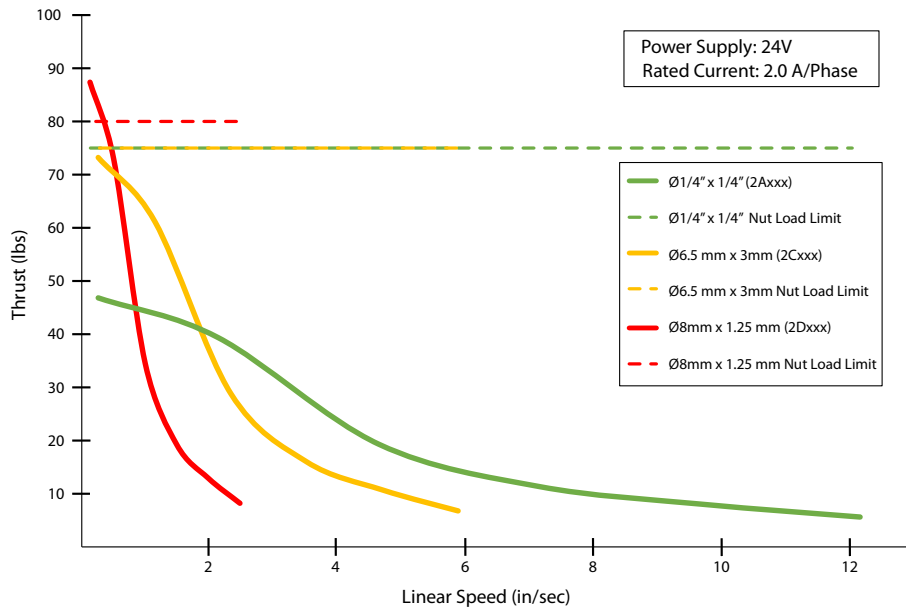

STP-LE17-3xxxx NEMA 17 Step Motor Linear Actuators (Triple-stack motors)

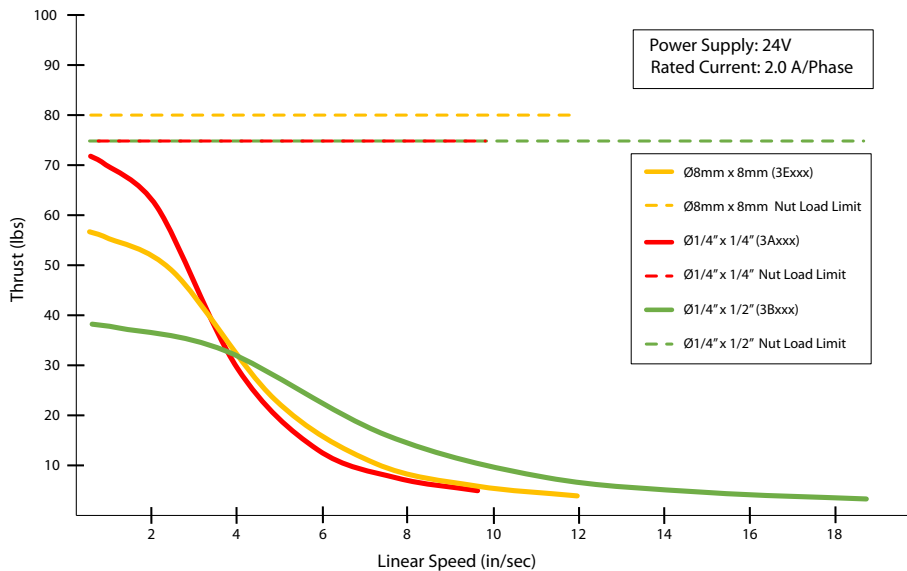

SureStep® Linear Actuator Thrust vs. Speed Charts, continued

STP-LE23-1xxxx NEMA 23 Step Motor Linear Actuators (Single-stack motors)

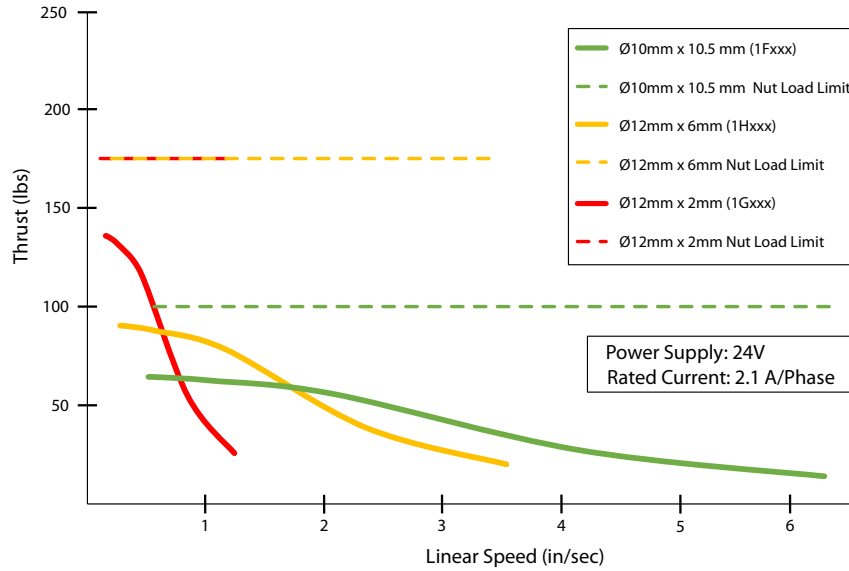

STP-LE23-3xxxx NEMA 23 Step Motor Linear Actuators (Triple-stack motors)

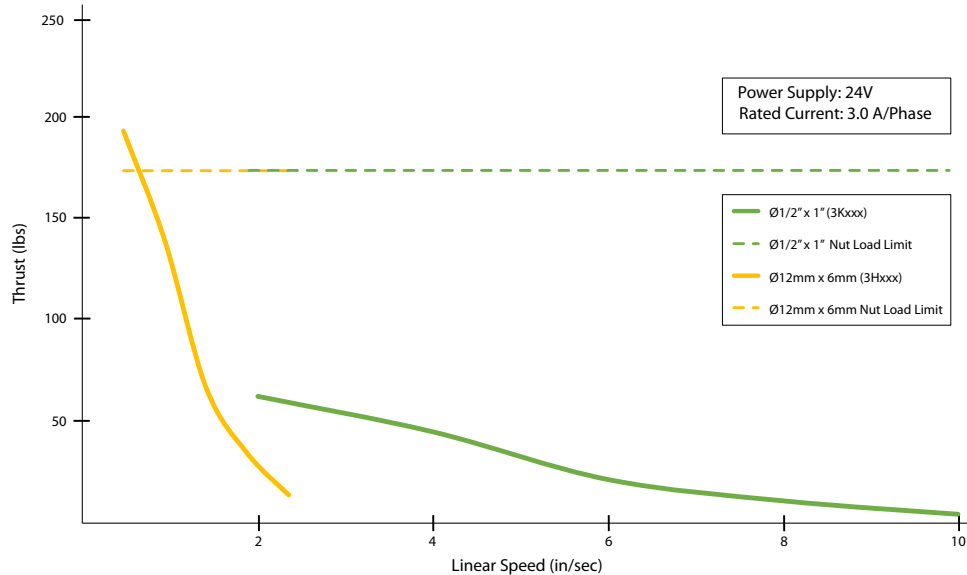



Linear Actuators

SureStep® Linear Actuator Dimensions and Cabling

STP-LE17-xxxxANN Motors

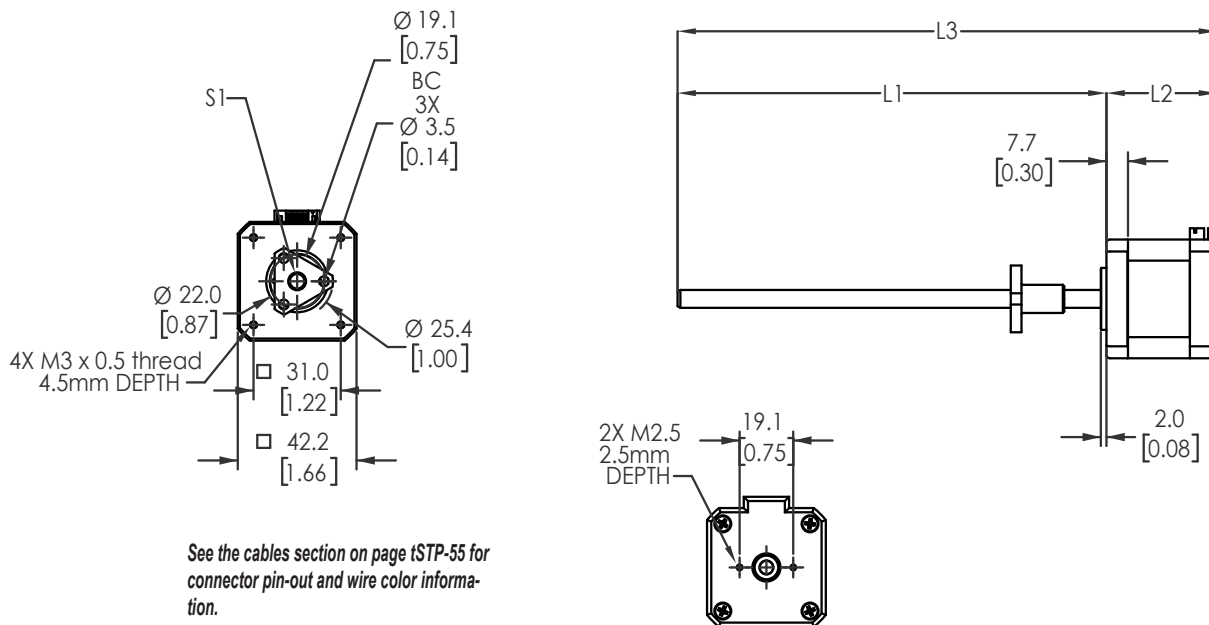

STP-LE17-xxxxANN Dimensions (mm [inch])				
Part #	L1	L2	L3	S1
<u>STP-LE17-2A06ANN</u>	152.4 [6.00]	39.3 [1.55]	191.7 [7.55]	6.4 [0.25] 0.25" Lead
<u>STP-LE17-2A09ANN</u>	228.6 [9.00]	39.3 [1.55]	267.9 [10.55]	6.4 [0.25] 0.25" Lead
<u>STP-LE17-2A12ANN</u>	304.8 [12.00]	39.3 [1.55]	344.1 [13.55]	6.4 [0.25] 0.25" Lead
<u>STP-LE17-2C06ANN</u>	152.4 [6.00]	39.3 [1.55]	191.7 [7.55]	6.5 [0.47] 3.0 mm Lead
<u>STP-LE17-2C09ANN</u>	228.6 [9.00]	39.3 [1.55]	267.9 [10.55]	6.5 [0.47] 3.0 mm Lead
<u>STP-LE17-2C12ANN</u>	304.8 [12.00]	39.3 [1.55]	344.1 [13.55]	6.5 [0.47] 3.0 mm Lead
<u>STP-LE17-2D06ANN</u>	152.4 [6.00]	39.3 [1.55]	191.7 [7.55]	8.0 [0.31] 1.25 mm Lead
<u>STP-LE17-2D09ANN</u>	228.6 [9.00]	39.3 [1.55]	267.9 [10.55]	8.0 [0.31] 1.25 mm Lead
<u>STP-LE17-2D12ANN</u>	304.8 [12.00]	39.3 [1.55]	344.1 [13.55]	8.0 [0.31] 1.25 mm Lead
<u>STP-LE17-3A06ANN</u>	152.4 [6.00]	47.8 [1.88]	200.2 [7.88]	6.4 [0.25] 0.25" Lead
<u>STP-LE17-3A09ANN</u>	228.6 [9.00]	47.8 [1.88]	276.4 [10.88]	6.4 [0.25] 0.25" Lead
<u>STP-LE17-3A12ANN</u>	304.8 [12.00]	47.8 [1.88]	352.6 [13.88]	6.4 [0.25] 0.25" Lead
<u>STP-LE17-3B06ANN</u>	152.4 [6.00]	47.8 [1.88]	200.2 [7.88]	6.4 [0.25] 0.5" Lead
<u>STP-LE17-3B09ANN</u>	228.6 [9.00]	47.8 [1.88]	276.4 [10.88]	6.4 [0.25] 0.5" Lead
<u>STP-LE17-3B12ANN</u>	304.8 [12.00]	47.8 [1.88]	352.6 [13.88]	6.4 [0.25] 0.5" Lead
<u>STP-LE17-3E06ANN</u>	152.4 [6.00]	47.8 [1.88]	200.2 [7.88]	8.0 [0.31] 8.0 mm Lead
<u>STP-LE17-3E09ANN</u>	228.6 [9.00]	47.8 [1.88]	276.4 [10.88]	8.0 [0.31] 8.0 mm Lead
<u>STP-LE17-3E12ANN</u>	304.8 [12.00]	47.8 [1.88]	352.6 [13.88]	8.0 [0.31] 8.0 mm Lead



Linear Actuators

SureStep® Linear Actuator Dimensions and Cabling

STP-LE17-xxxxADJ Motors

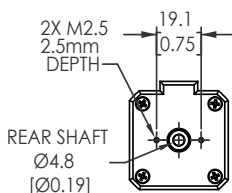
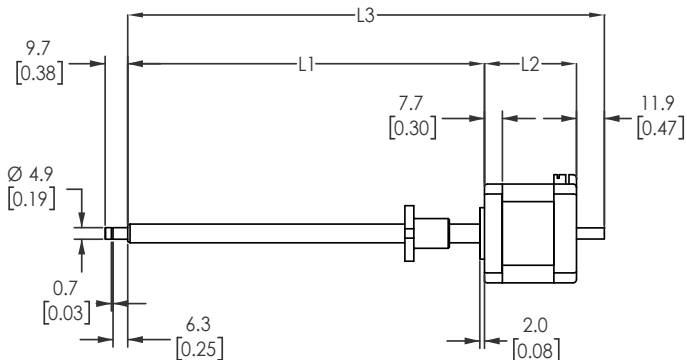
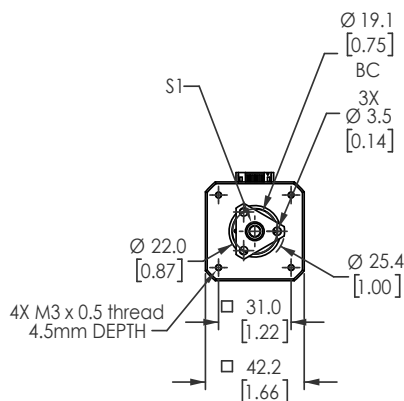

NOTE: On some screw codes, the journals are not machined completely smooth in order to keep from machining the screw to too small of a diameter. Some threads are still visible. This is intentional and will not affect bearing performance.



See the encoder compatibility section on page tSTP-56 for a list of compatible encoders.

See the cables section on page tSTP-55 for connector pin-out and wire color information.

STP-LE17-xxxxADJ Dimensions (mm [inch])				
Part #	L1	L2	L3	S1
STP-LE17-2A06ADJ	152.4 [6.00]	39.3 [1.55]	203.6 [8.02]	6.4 [0.25] 0.25" Lead
STP-LE17-2A09ADJ	228.6 [9.00]	39.3 [1.55]	279.8 [11.02]	6.4 [0.25] 0.25" Lead
STP-LE17-2A12ADJ	304.8 [12.00]	39.3 [1.55]	356.0 [14.02]	6.4 [0.25] 0.25" Lead
STP-LE17-2C06ADJ	152.4 [6.00]	39.3 [1.55]	203.6 [8.02]	6.5 [0.47] 3.0 mm Lead
STP-LE17-2C09ADJ	228.6 [9.00]	39.3 [1.55]	279.8 [11.02]	6.5 [0.47] 3.0 mm Lead
STP-LE17-2C12ADJ	304.8 [12.00]	39.3 [1.55]	356.0 [14.02]	6.5 [0.47] 3.0 mm Lead
STP-LE17-2D06ADJ	152.4 [6.00]	39.3 [1.55]	203.6 [8.02]	8.0 [0.31] 1.25 mm Lead
STP-LE17-2D09ADJ	228.6 [9.00]	39.3 [1.55]	279.8 [11.02]	8.0 [0.31] 1.25 mm Lead
STP-LE17-2D12ADJ	304.8 [12.00]	39.3 [1.55]	356.0 [14.02]	8.0 [0.31] 1.25 mm Lead
STP-LE17-3A06ADJ	152.4 [6.00]	47.8 [1.88]	212.1 [8.35]	6.4 [0.25] 0.25" Lead
STP-LE17-3A09ADJ	228.6 [9.00]	47.8 [1.88]	288.3 [11.35]	6.4 [0.25] 0.25" Lead
STP-LE17-3A12ADJ	304.8 [12.00]	47.8 [1.88]	364.5 [15.35]	6.4 [0.25] 0.25" Lead
STP-LE17-3B06ADJ	152.4 [6.00]	47.8 [1.88]	212.1 [8.35]	6.4 [0.25] 0.5" Lead
STP-LE17-3B09ADJ	228.6 [9.00]	47.8 [1.88]	288.3 [11.35]	6.4 [0.25] 0.5" Lead
STP-LE17-3B12ADJ	304.8 [12.00]	47.8 [1.88]	364.5 [15.35]	6.4 [0.25] 0.5" Lead
STP-LE17-3E06ADJ	152.4 [6.00]	47.8 [1.88]	212.1 [8.35]	8.0 [0.31] 8.0 mm Lead
STP-LE17-3E09ADJ	228.6 [9.00]	47.8 [1.88]	288.3 [11.35]	8.0 [0.31] 8.0 mm Lead
STP-LE17-3E12ADJ	304.8 [12.00]	47.8 [1.88]	364.5 [15.35]	8.0 [0.31] 8.0 mm Lead



Linear Actuators

SureStep® Linear Actuator Dimensions and Cabling

STP-LE23-xxxxANN Motors

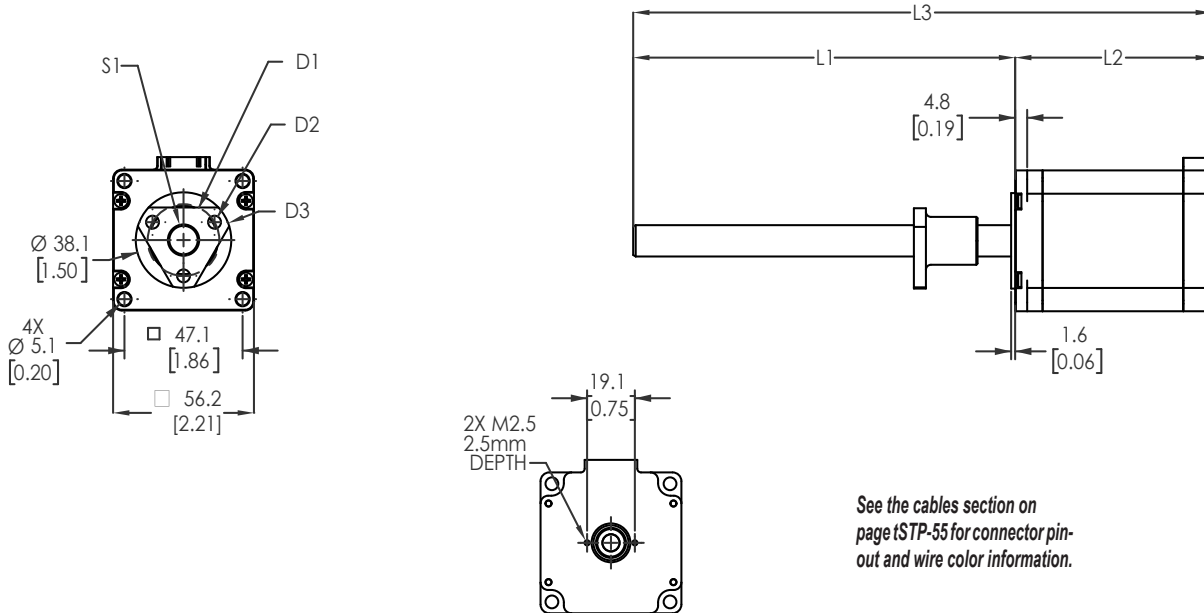

See the cables section on page tSTP-55 for connector pin-out and wire color information.

STP-LE23-xxxxANN Dimensions (mm [inch])							
Part #	L1	L2	L3	D1	D2	D3	S1
STP-LE23-1F06ANN	152.4 [6.00]	44.5 [1.75]	196.9 [7.75]	Ø22.2 [0.87] BC	3x Ø3.56 [0.14]	Ø29.5 [1.16]	10.0 [0.39] 10.5 mm Lead
STP-LE23-1F09ANN	228.6 [9.00]	44.5 [1.75]	273.1 [10.75]	Ø22.2 [0.87] BC	3x Ø3.56 [0.14]	Ø29.5 [1.16]	10.0 [0.39] 10.5 mm Lead
STP-LE23-1F12ANN	304.8 [12.00]	44.5 [1.75]	349.3 [13.75]	Ø22.2 [0.87] BC	3x Ø3.56 [0.14]	Ø29.5 [1.16]	10.0 [0.39] 10.5 mm Lead
STP-LE23-1G06ANN	152.4 [6.00]	44.5 [1.75]	196.9 [7.75]	Ø28.58 [1.13] BC	3x Ø5.2 [0.20]	Ø38.1 [1.50]	12.0 [0.47] 2.0 mm Lead
STP-LE23-1G09ANN	228.6 [9.00]	44.5 [1.75]	273.1 [10.75]	Ø28.58 [1.13] BC	3x Ø5.2 [0.20]	Ø38.1 [1.50]	12.0 [0.47] 2.0 mm Lead
STP-LE23-1G12ANN	304.8 [12.00]	44.5 [1.75]	349.3 [13.75]	Ø28.58 [1.13] BC	3x Ø5.2 [0.20]	Ø38.1 [1.50]	12.0 [0.47] 2.0 mm Lead
STP-LE23-1H06ANN	152.4 [6.00]	44.5 [1.75]	196.9 [7.75]	Ø28.58 [1.13] BC	3x Ø5.2 [0.20]	Ø38.1 [1.50]	12.0 [0.47] 6.0 mm Lead
STP-LE23-1H09ANN	228.6 [9.00]	44.5 [1.75]	273.1 [10.75]	Ø28.58 [1.13] BC	3x Ø5.2 [0.20]	Ø38.1 [1.50]	12.0 [0.47] 6.0 mm Lead
STP-LE23-1H12ANN	304.8 [12.00]	44.5 [1.75]	349.3 [13.75]	Ø28.58 [1.13] BC	3x Ø5.2 [0.20]	Ø38.1 [1.50]	12.0 [0.47] 6.0 mm Lead
STP-LE23-3H06ANN	152.4 [6.00]	78.5 [3.09]	230.9 [9.09]	Ø28.58 [1.13] BC	3x Ø5.2 [0.20]	Ø38.1 [1.50]	12.0 [0.47] 6.0 mm Lead
STP-LE23-3H09ANN	228.6 [9.00]	78.5 [3.09]	307.1 [12.09]	Ø28.58 [1.13] BC	3x Ø5.2 [0.20]	Ø38.1 [1.50]	12.0 [0.47] 6.0 mm Lead
STP-LE23-3H12ANN	304.8 [12.00]	78.5 [3.09]	383.3 [15.09]	Ø28.58 [1.13] BC	3x Ø5.2 [0.20]	Ø38.1 [1.50]	12.0 [0.47] 6.0 mm Lead
STP-LE23-3K06ANN	152.4 [6.00]	78.5 [3.09]	230.9 [9.09]	Ø28.58 [1.13] BC	3x Ø5.2 [0.20]	Ø38.1 [1.50]	12.5 [0.50] 1in Lead
STP-LE23-3K09ANN	228.6 [9.00]	78.5 [3.09]	307.1 [12.09]	Ø28.58 [1.13] BC	3x Ø5.2 [0.20]	Ø38.1 [1.50]	12.5 [0.50] 1in Lead
STP-LE23-3K12ANN	304.8 [12.00]	78.5 [3.09]	383.3 [15.09]	Ø28.58 [1.13] BC	3x Ø5.2 [0.20]	Ø38.1 [1.50]	12.5 [0.50] 1in Lead

SureStep® Linear Actuator Dimensions and Cabling

STP-LE23-xxxxADJ Motors

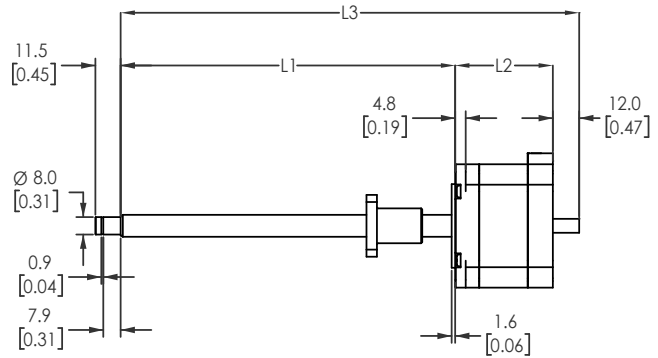
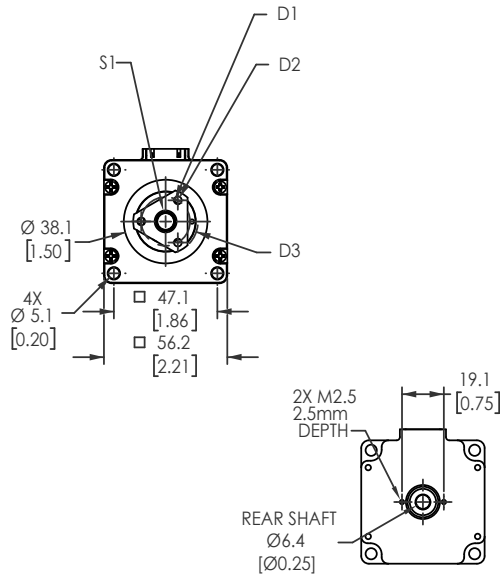

See the cables section on page tSTP-55 for connector pin-out and wire color information.

See the encoder compatibility section on page tSTP-56 for a list of compatible encoders.

STP-LE23-xxxxADJ Dimensions (mm [inch])							
Part #	L1	L2	L3	D1	D2	D3	S1
STP-LE23-1F06ADJ	152.4 [6.00]	44.5 [1.75]	208.9 [8.22]	Ø22.2 [0.87] BC	3x Ø3.56 [0.14]	Ø29.5 [1.16]	10.0 [0.39] 10.5 mm Lead
STP-LE23-1F09ADJ	228.6 [9.00]	44.5 [1.75]	285.1 [11.22]	Ø22.2 [0.87] BC	3x Ø3.56 [0.14]	Ø29.5 [1.16]	10.0 [0.39] 10.5 mm Lead
STP-LE23-1F12ADJ	304.8 [12.00]	44.5 [1.75]	361.3 [14.22]	Ø22.2 [0.87] BC	3x Ø3.56 [0.14]	Ø29.5 [1.16]	10.0 [0.39] 10.5 mm Lead
STP-LE23-1G06ADJ	152.4 [6.00]	44.5 [1.75]	208.9 [8.22]	Ø28.58 [1.13] BC	3x Ø5.2 [0.20]	Ø38.1 [1.50]	12.0 [0.47] 2.0 mm Lead
STP-LE23-1G09ADJ	228.6 [9.00]	44.5 [1.75]	285.1 [11.22]	Ø28.58 [1.13] BC	3x Ø5.2 [0.20]	Ø38.1 [1.50]	12.0 [0.47] 2.0 mm Lead
STP-LE23-1G12ADJ	304.8 [12.00]	44.5 [1.75]	361.3 [14.22]	Ø28.58 [1.13] BC	3x Ø5.2 [0.20]	Ø38.1 [1.50]	12.0 [0.47] 2.0 mm Lead
STP-LE23-1H06ADJ	152.4 [6.00]	44.5 [1.75]	208.9 [8.22]	Ø28.58 [1.13] BC	3x Ø5.2 [0.20]	Ø38.1 [1.50]	12.0 [0.47] 6.0 mm Lead
STP-LE23-1H09ADJ	228.6 [9.00]	44.5 [1.75]	285.1 [11.22]	Ø28.58 [1.13] BC	3x Ø5.2 [0.20]	Ø38.1 [1.50]	12.0 [0.47] 6.0 mm Lead
STP-LE23-1H12ADJ	304.8 [12.00]	44.5 [1.75]	361.3 [14.22]	Ø28.58 [1.13] BC	3x Ø5.2 [0.20]	Ø38.1 [1.50]	12.0 [0.47] 6.0 mm Lead
STP-LE23-3H06ADJ	152.4 [6.00]	78.5 [3.09]	242.9 [9.06]	Ø28.58 [1.13] BC	3x Ø5.2 [0.20]	Ø38.1 [1.50]	12.0 [0.47] 6.0 mm Lead
STP-LE23-3H09ADJ	228.6 [9.00]	78.5 [3.09]	319.1 [12.56]	Ø28.58 [1.13] BC	3x Ø5.2 [0.20]	Ø38.1 [1.50]	12.0 [0.47] 6.0 mm Lead
STP-LE23-3H12ADJ	304.8 [12.00]	78.5 [3.09]	395.3 [15.56]	Ø28.58 [1.13] BC	3x Ø5.2 [0.20]	Ø38.1 [1.50]	12.0 [0.47] 6.0 mm Lead
STP-LE23-3K06ADJ	152.4 [6.00]	78.5 [3.09]	242.9 [9.06]	Ø28.58 [1.13] BC	3x Ø5.2 [0.20]	Ø38.1 [1.50]	12.5 [0.50] 1in Lead
STP-LE23-3K09ADJ	228.6 [9.00]	78.5 [3.09]	319.1 [12.56]	Ø28.58 [1.13] BC	3x Ø5.2 [0.20]	Ø38.1 [1.50]	12.5 [0.50] 1in Lead
STP-LE23-3K12ADJ	304.8 [12.00]	78.5 [3.09]	395.3 [15.56]	Ø28.58 [1.13] BC	3x Ø5.2 [0.20]	Ø38.1 [1.50]	12.5 [0.50] 1in Lead

SureStep® Linear Actuators Cables

Cables for SureStep Series Linear Actuators			
Part Number	Price	Description	Drawing
STP-LA-EXT17-006	\$25.00	SureStep extension cable, 6-pin (4-wire) connector to pigtail, 6ft cable length. For use with SureStep NEMA 17 STP-LE series linear actuators.	PDF
STP-LA-EXT17-010	\$32.00	SureStep extension cable, 6-pin (4-wire) connector to pigtail, 10ft cable length. For use with SureStep NEMA 17 STP-LE series linear actuators.	PDF
STP-LA-EXT17-020	\$53.00	SureStep extension cable, 6-pin (4-wire) connector to pigtail, 20ft cable length. For use with SureStep NEMA 17 STP-LE series linear actuators.	PDF
STP-LA-EXT23-006	\$28.00	SureStep extension cable, 6-pin (4-wire) connector to pigtail, 6ft cable length. For use with SureStep NEMA 23 STP-LE series linear actuators.	PDF
STP-LA-EXT23-010	\$37.00	SureStep extension cable, 6-pin (4-wire) connector to pigtail, 10ft cable length. For use with SureStep NEMA 23 STP-LE series linear actuators.	PDF
STP-LA-EXT23-020	\$57.00	SureStep extension cable, 6-pin (4-wire) connector to pigtail, 20ft cable length. For use with SureStep NEMA 23 STP-LE series linear actuators.	PDF

STP-LA-EXT17-0xx Dimensions (mm [in])

CONNECTOR
JST # PHR-6
PIN JST # SPH-002T-P0.5

CABLE
ALHPAWIRE # 1604
(24AWG/4C)
OR EQUIVALENT

PINOUT CHART		
PIN #	COLOR	WIRE
1	RED	A+
2	N/A	
3	YELLOW	A-
4	GREEN	B+
5	N/A	
6	BLACK	B-

CABLES		
CABLE PART #	LENGTH L (IN)	LENGTH L (mm)
STP-LA-EXT17-006	72	1828
STP-LA-EXT17-010	120	3048
STP-LA-EXT17-020	240	6096

VIEW FROM WIRE ENTRANCE

STP-LA-EXT17-006

STP-LA-EXT23-0xx Dimensions (mm [in])

CONNECTOR
JST # XHP-6
PIN JST # SXH-001T-P0.6

CABLE
BELDEN # 8444
(22AWG/4C)
OR EQUIVALENT

PINOUT CHART		
PIN #	COLOR	WIRE
1	RED	A+
2	N/A	
3	WHITE	A-
4	GREEN	B+
5	N/A	
6	BLACK	B-

CABLES		
CABLE PART #	LENGTH L (IN)	LENGTH L (mm)
STP-LA-EXT23-006	72	1828
STP-LA-EXT23-010	120	3048
STP-LA-EXT23-020	240	6096

VIEW FROM WIRE ENTRANCE

STP-LA-EXT23-006

Linear Actuators

SureStep® Linear Actuators Accessories

Replacement Parts for SureStep Series Linear Actuators			
Part Number	Price	Description	Drawing
STP-LA-NTFA	\$21.00	SureStep lead screw flange nut, replacement, triangular, 0.25 in/rev, 0.25 inch lead screw diameter. For use with SureStep STP-LE series screw code A linear actuators.	PDF
STP-LA-NTFB	\$21.00	SureStep lead screw flange nut, replacement, triangular, 0.5 in/rev, 0.25 inch lead screw diameter. For use with SureStep STP-LE series screw code B linear actuators.	PDF
STP-LA-NTFC	\$21.00	SureStep lead screw flange nut, replacement, triangular, 3mm/rev, 6.5 mm lead screw diameter. For use with SureStep STP-LE series screw code C linear actuators.	PDF
STP-LA-NTFD	\$21.00	SureStep lead screw flange nut, replacement, triangular, 1.25 mm/rev, 8mm lead screw diameter. For use with SureStep STP-LE series screw code D linear actuators.	PDF
STP-LA-NTFE	\$21.00	SureStep lead screw flange nut, replacement, triangular, 8mm/rev, 8mm lead screw diameter. For use with SureStep STP-LE series screw code E linear actuators.	PDF
STP-LA-NTFF	\$24.00	SureStep lead screw flange nut, replacement, triangular, 10.5 mm/rev, 10mm lead screw diameter. For use with SureStep STP-LE series screw code F linear actuators.	PDF
STP-LA-NTFG	\$37.00	SureStep lead screw flange nut, replacement, triangular, 2mm/rev, 12mm lead screw diameter. For use with SureStep STP-LE series screw code G linear actuators.	PDF
STP-LA-NTFH	\$37.00	SureStep lead screw flange nut, replacement, triangular, 6mm/rev, 12mm lead screw diameter. For use with SureStep STP-LE series screw code H linear actuators.	PDF
STP-LA-NTFK	\$37.00	SureStep lead screw flange nut, replacement, triangular, 1in/rev, 0.5 inch lead screw diameter. For use with SureStep STP-LE series screw code K linear actuators.	PDF
STP-LA-NRFA	\$21.00	SureStep lead screw flange nut, round, 0.25 in/rev, 0.25 inch lead screw diameter. For use with SureStep STP-LE series screw code A linear actuators.	PDF
STP-LA-NRFB	\$21.00	SureStep lead screw flange nut, round, 0.5 in/rev, 0.25 in lead screw diameter. For use with SureStep STP-LE series screw code B linear actuators.	PDF
STP-LA-NRFC	\$21.00	SureStep lead screw flange nut, round, 3mm/rev, 6.5 mm lead screw diameter. For use with SureStep STP-LE series screw code C linear actuators.	PDF
STP-LA-NRFD	\$21.00	SureStep lead screw flange nut, round, 1.25 mm/rev, 8mm lead screw diameter. For use with SureStep STP-LE series screw code D linear actuators.	PDF
STP-LA-NRFE	\$21.00	SureStep lead screw flange nut, round, 8mm/rev, 8mm lead screw diameter. For use with SureStep STP-LE series screw code E linear actuators.	PDF
STP-LA-NRFF	\$24.00	SureStep lead screw flange nut, round, 10.5 mm/rev, 10mm lead screw diameter. For use with SureStep STP-LE series screw code F linear actuators.	PDF
STP-LA-NRFG	\$37.00	SureStep lead screw flange nut, round, 2mm/rev, 12mm lead screw diameter. For use with SureStep STP-LE series screw code G linear actuators.	PDF
STP-LA-NRFH	\$37.00	SureStep lead screw flange nut, round, 6mm/rev, 12mm lead screw diameter. For use with SureStep STP-LE series screw code H linear actuators.	PDF
STP-LA-NRFK	\$37.00	SureStep lead screw flange nut, round, 1in/rev, 0.5 inch lead screw diameter. For use with SureStep STP-LE series screw code K linear actuators.	PDF

All STP-LA series nuts are formed from TECAFORM AD AF (a PTFE-infused polymer) and require no lubrication. Using any sort of lubricant is not recommended as it will eventually dry out and contaminate the screw.

SureStep Linear Actuators have a "Screw Code" built into the part number. Each screw has a specific diameter and lead (pitch). The "Y" variable in the Linear Actuator part numbers below represents the Screw Code:

STP-LE17-xYxxxxx

STP-LE23-xYxxxxx

To find a compatible nut, match the actuator's Screw Code to the nut screw code ("Y" below):

STP-LA-xxxY

Example: An [STP-LA-NTFB](#) nut will fit onto an [STP-LE17-3B06ADJ](#) actuator.



[STP-LA-NTFA](#)



[STP-LA-NRFK](#)

NEMA 17 Linear Actuator Compatible Encoders

NEMA 17 Compatible Encoders	
CUI Devices Configurable Encoders	SureStep Encoders
AMT102-V (config. ppr, Push-pull)	STP-MTRA-ENC1 (1000ppr, Line Driver)
AMT103-V (config. ppr, Push-pull)	STP-MTRA-ENC3 (400ppr, Line Driver)
AMT112S-V (config. ppr, Push-pull)	STP-MTRA-ENC2 (1000ppr, Push-pull)
AMT112Q-V (config. ppr, Line Driver)	STP-MTRA-ENC4 (400ppr, Push-pull)
AMT312D-V (config. ppr, Line Driver)	STP-MTRA-ENC9 (config. ppr, Line Driver)
AMT312S-V (config. ppr, Push-pull)	STP-MTRA-ENC10 (config. ppr, Push-pull)

NEMA 23 Linear Actuator Compatible Encoders

NEMA 23 Compatible Encoders	
CUI Devices Configurable Encoders	SureStep Encoders
AMT102-V (config. ppr, Push-pull)	STP-MTRA-ENC5 (1000ppr, Line Driver)
AMT103-V (config. ppr, Push-pull)	STP-MTRA-ENC7 (400ppr, Line Driver)
AMT112S-V (config. ppr, Push-pull)	STP-MTRA-ENC6 (1000ppr, Push-pull)
AMT112Q-V (config. ppr, Line Driver)	STP-MTRA-ENC8 (400ppr, Push-pull)
AMT312D-V (config. ppr, Line Driver)	STP-MTRA-ENC9 (config. ppr, Line Driver)
AMT312S-V (config. ppr, Push-pull)	STP-MTRA-ENC10 (config. ppr, Push-pull)



Stepping System Accessories

AMT Series Stepping System Encoders

AMT Series Encoder Compatibility							
Part Number	Max PPR	Bore Diameter	Output Type	PLC Compatibility	Encoder Cable	Configuration Cable	Motor Compatibility
AMT102-V	2048	2mm, 3mm, 1/8", 4mm, 3/16", 5mm, 6mm, 1/4", 8mm	push-pull (totem) (radial connector)	BRX ¹ , CLICK C0-1xDxE-D2	CUI-3131-x CUI-3132-1FT	n/a	NEMA 14, 17, 23 dual-shaft
AMT103-V²	2048		push-pull (totem) (axial connector)		CUI-435-x CUI-3934-6FT		
AMT112S-V	4096		push-pull (totem)		AMT-17C-1-x		
AMT112Q-V	4096		line driver (differential)	P2-HSI, P3-HSI, BRX ¹ , CLICK C0-1xDxE-D2	AMT-17C-1-x	AMT-PGRM-17C	
AMT312D-V	4096		line driver (differential) encoder+commutation	P2-HSI, P3-HSI, BRX ¹ , CLICK C0-1xDxE-D2	AMT-17C-1-x	AMT-PGRM-17C	
AMT312S-V	4096		push-pull (totem) encoder+commutation	BRX ¹ , CLICK C0-1xDxE-D2	AMT-17C-1-x		
AMT132S-V	4096		push-pull (totem)		AMT-18C-3-x		
AMT132Q-V	4096	9mm, 3/8", 10mm, 11mm, 12mm, 1/2", 13mm, 14mm, 5/8"	line driver (differential)	P2-HSI, P3-HSI, BRX ¹ , CLICK C0-1xDxE-D2	AMT-18C-3-x	AMT-PGRM-18C	NEMA 34 and 42 ³ dual-shaft (Does not fit STP-MTRAC-34 motors)
AMT332S-V	4096		push-pull (totem) encoder+commutation	BRX ¹ , CLICK C0-1xDxE-D2	AMT-18C-3-x		
AMT332D-V	4096		line driver (differential) encoder+commutation	P2-HSI, P3-HSI, BRX ¹ , CLICK C0-1xDxE-D2	AMT-18C-3-x		

Note: For specific AutomationDirect PLC and step motor model compatibility, please see Appendix A in the SureStep User Manual.
 1 - Requires FC-ISO-C (see wiring diagrams for DIP switch settings).
 2 - For AMT103-V to maintain NEMA23 compatibility, CUI-KIT-2 must be purchased to use the standard wide base for mounting.
 3 - For STP-MTRAC(H)-42 series motors, encoder mounting kit STP-MTRA-42ENC is required.

AMT Series Encoder Signal Cables			
Part Number	Price	Description	Drawing
CUI-3132-1FT	\$5.00	CUI Devices encoder cable, 5-pin connector to pigtail, 1ft cable length. For use with CUI Devices AMT102 encoders.	PDF
CUI-3131-6FT	\$10.50	CUI Devices encoder cable, 5-pin connector to pigtail, shielded, twisted pair, 6ft cable length. For use with CUI Devices AMT102 encoders.	PDF
CUI-3131-10FT	\$30.00	CUI Devices encoder cable, 5-pin connector to pigtail, shielded, twisted pair, 10ft cable length. For use with CUI Devices AMT102 encoders.	PDF
CUI-3131-20FT	\$49.00	CUI Devices encoder cable, 5-pin connector to pigtail, shielded, twisted pair, 20ft cable length. For use with CUI Devices AMT102 encoders.	PDF
CUI-435-1FT	\$5.50	CUI Devices encoder cable, 5-pin connector to pigtail, 1ft cable length. For use with CUI Devices AMT103 encoders.	PDF
CUI-3934-6FT	\$26.50	CUI Devices encoder cable, 5-pin connector to pigtail, shielded, twisted pair, 6ft cable length. For use with CUI Devices AMT103 encoders.	PDF
CUI-435-10FT	\$22.00	CUI Devices encoder cable, 5-pin connector to pigtail, 10ft cable length. For use with CUI Devices AMT103 encoders.	PDF
CUI-435-20FT	\$30.00	CUI Devices encoder cable, 5-pin connector to pigtail, 20ft cable length. For use with CUI Devices AMT103 encoders.	PDF

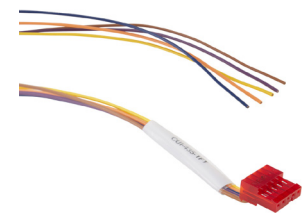

CUI-435-1FT
CUI-435-10FT
CUI-435-20FT



CUI-3131-6FT
CUI-3131-10FT
CUI-3131-20FT

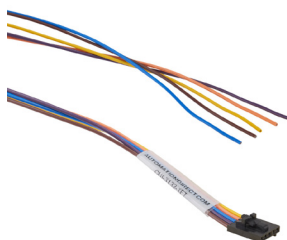

CUI-3132-1FT

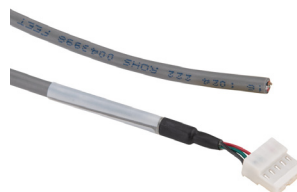

CUI-3934-6FT



Stepping System Accessories

AMT Series Stepping System Encoders

AMT Series Encoder Signal Cables			
Part Number	Price	Description	Drawing
<u>AMT-17C-1-036</u>	\$40.00	CUI Devices encoder cable, 17-pin connector to pigtail, shielded, twisted pair, 3ft cable length. For use with CUI Devices AMT112 and AMT312 encoders.	<u>PDF</u>
<u>AMT-17C-1-072</u>	\$81.00	CUI Devices encoder cable, 17-pin connector to pigtail, shielded, twisted pair, 6ft cable length. For use with CUI Devices AMT112 and AMT312 encoders.	<u>PDF</u>
<u>AMT-17C-1-120</u>	\$121.00	CUI Devices encoder cable, 17-pin connector to pigtail, shielded, twisted pair, 10ft cable length. For use with CUI Devices AMT112 and AMT312 encoders.	<u>PDF</u>
<u>AMT-18C-3-036</u>	\$27.50	CUI Devices encoder cable, 18-pin connector to pigtail, shielded, twisted pair, 3ft cable length. For use with AMT13 and AMT33 encoders.	<u>PDF</u>
<u>AMT-18C-3-072</u>	\$67.00	CUI Devices encoder cable, 18-pin connector to pigtail, shielded, twisted pair, 6ft cable length. For use with AMT13 and AMT33 encoders.	<u>PDF</u>
<u>AMT-18C-3-120</u>	\$96.00	CUI Devices encoder cable, 18-pin connector to pigtail, shielded, twisted pair, 10ft cable length. For use with AMT13 and AMT33 encoders.	<u>PDF</u>

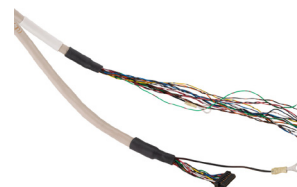

**AMT-17C-1-036
AMT-17C-1-072
AMT-17C-1-120**

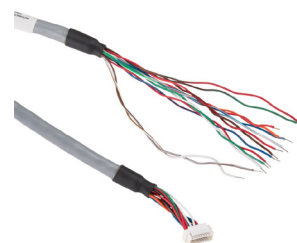

**AMT-18C-3-036
AMT-18C-3-072
AMT-18C-3-120**

AMT Series Encoders Programming Cables		
Part Number	Price	Description
<u>AMT-PGRM-17C</u>	\$27.00	CUI Devices programming cable, miniB-USB to 17-pin connector, 1ft cable length. For use with CUI Devices AMT112 and AMT312 encoders.
<u>AMT-PGRM-18C</u>	\$24.50	CUI Devices programming cable, miniB-USB to 18-pin connector, 1ft cable length. For use with CUI Devices AMT13 and AMT33 encoders.



AMT-PGRM-17C



AMT-PGRM-18C



Stepping System Accessories

SureStep® Stepping System Encoders

Sure Step Series Encoder Compatibility						
Part Number	PPR	Bore Diameter	Output Type	Encoder Cable	PLC Compatibility	Motor Compatibility
<u>STP-MTRA-ENC1</u>	1000	5mm	Line Driver	STP-CBL-EAxx	P2-HSI, P3-HSI, BRX*, CLICK C0-1xDxE-D*	STP-MTRx-14xxxD STP-MTRx-14xxxE STP-MTRx-17xxxD STP-MTRx-17xxxE Standard STP-MTRD-xxxxE
<u>STP-MTRA-ENC2</u>			Push-pull (totem)	STP-CBL-EDxx	BRX*, CLICK C0-1xDxE-D*	
<u>STP-MTRA-ENC3</u>	400		Line Driver	STP-CBL-EAxx	P2-HSI, P3-HSI, BRX*, CLICK C0-1xDxE-D*	
<u>STP-MTRA-ENC4</u>			Push-pull (totem)	STP-CBL-EDxx	BRX*, CLICK C0-1xDxE-D*	
<u>STP-MTRA-ENC5</u>	1000	0.25 inch	Line Driver	STP-CBL-EAxx	P2-HSI, P3-HSI, BRX*, CLICK C0-1xDxE-D*	STP-MTRx-23xxxD STP-MTRx-23xxxE STP-MTRAC-23xxxD
<u>STP-MTRA-ENC6</u>			Push-pull (totem)	STP-CBL-EDxx	BRX*, CLICK C0-1xDxE-D*	
<u>STP-MTRA-ENC7</u>	400		Line Driver	STP-CBL-EAxx	P2-HSI, P3-HSI, BRX*, CLICK C0-1xDxE-D*	
<u>STP-MTRA-ENC8</u>			Push-pull (totem)	STP-CBL-EDxx	BRX*, CLICK C0-1xDxE-D*	
<u>STP-MTRA-ENC11</u>	1000	0.375 inch	Line Driver	STP-CBL-EAxx	P2-HSI, P3-HSI, BRX*, CLICK C0-1xDxE-D*	STP-MTRAC-34xxxD
<u>STP-MTRA-ENC12</u>			Push-pull (totem)	STP-CBL-EDxx	BRX*, CLICK C0-1xDxE-D*	
<u>STP-MTRA-ENC13</u>	400		Line Driver	STP-CBL-EAxx	P2-HSI, P3-HSI, BRX*, CLICK C0-1xDxE-D*	
<u>STP-MTRA-ENC14</u>			Push-pull (totem)	STP-CBL-EDxx	BRX*, CLICK C0-1xDxE-D*	

* Requires FC-ISO-C