



Stepping Drives

Leadshine 2-phase Digital Stepper Drives

Leadshine has been an industry leading motion control supplier since 1997, and is one of the largest stepper drive manufacturers in the world. Leadshine steppers offer high quality products (Leadshine factories are ISO9001 certified) at very affordable prices. Leadshine steppers are simple, easy to use, long-lasting, and reliable.

AutomationDirect sells a wide range of linear and switching power supplies, stepper motors, cables, and PLCs with hi-speed outputs that are compatible with Leadshine stepper drives.

Features

- 2-phase digital stepper drives
- Anti-resonance for optimal torque, extra smooth motion, low motor heating and noise
- Motor auto-config on power up
- All drives support step and direction control, some models support CW/CCW as well
- Micro-stepping for smooth motor movement
- DIP switch configurable
- Wide range of input voltages supported (12-110 VDC, 18-80 VAC)
- Pulse input frequency up to 200kHz
- Soft-start with no "jump" when powered on
- Automatic idle-current reduction
- Protections for over-voltage and over-current
- NEMA 11, 14, 17, 23, 24, 34 and 42 frame size step motors supported



Leadshine Series – Drives Features Comparison ¹								
Drive Model	DM322E	DM542E	DM556E	DM860E	DMA860E	DM805-AI	EM542S	EM556S
Price	\$27.50	\$39.00	\$43.00	\$53.00	\$69.00	\$113.00	\$50.00	\$61.00
Drawing	PDF	PDF	PDF	PDF	PDF	PDF	PDF	PDF
Drive Type	2-phase digital stepper drive							
Supply Voltage	12–30 VDC (24 VDC typical)	20–50 VDC (24–48 VDC typical)		24–74 VDC (48–68 VDC typical)	24–110 VDC (48–90 VDC typical) or 18–80 VAC (36–70 VAC typical)	20–80 VDC (30–60 VDC typical)	20–50 VDC (24–48 VDC typical)	
Pulse Input Type	Single-ended ²	Differential, Single-ended				Single-ended ²	Differential, Single-ended	
Step Input Modes	Step & Direction			Step & Direction, CW & CCW		Step & Direction, Analog input	Step & Direction, CW & CCW	
Digital Input Voltage	5V (add a 1K resistor to accept +12V input, or a 2K resistor to accept +24V input)						DIP switch selectable for 5V or 24V	
PPR Range	400–12800	400–25600		400–51200		200–12800	200–25600	
Motor Output Current Range	0.3–2.2 A peak (0.2–1.6 RMS)	1.0–4.2 A peak (0.7–3.0 RMS)	1.8–5.6 A peak (1.3–4.0 RMS)	2.4–7.2 A peak (1.7–5.1 RMS)		2.6–7.0 A peak (0.3–5.0 RMS)	0.5–4.2A peak (0.4–2.9 RMS)	0.5–5.6A peak (0.4–3.9 RMS)
Digital Output	No						+24VDC (Brake and Fault Detection)	
Self-test Capable	No	No	No	No	No	Yes	Yes	Yes
Special Features	Soft-start, motor auto-config				Accepts a DC or an AC power supply, soft-start, motor auto-config	Built-in pulse generator, command source	Auto-tuning, soft-start, fault and brake outputs, shaft lock	

¹ - Refer to Specifications Tables for detailed specifications.

² - See the User Manual or Quick Start Guide for instructions on wiring Single-Ended drives to a Differential (Line Driver) controller.



Stepping Drives

EM542S, EM556S

The EM542S and EM556S are digital stepper drives capable of pulse and direction as well as CW and CCW operation, with motor auto-configuration on power up and self-test capability. EM542S and EM556S have a built-in current-limiting resistor (on a switch) to allow either 5V or 24V input pulses. They also include a fault and a brake output, and a shaft lock feature. The brake output can be used with an external holding brake to hold the motor in place if power fails or the drive is disabled - you lose power, the brake engages. The shaft lock is set via DIP switch and will lock the motor into position using phase current, but only works when the drive has power.



EM542S

Leadshine EM542S, EM556S Specifications		
Drive Model	EM542S	EM556S
Output Current ¹	0.5-4.2A peak (0.4-2.9 RMS)	0.5-5.6A peak (0.4-3.9 RMS)
Input Voltage	20-50 VDC (24-48 VDC typical)	
Logic Signal Current	7-16 mA (10mA typical)	
Pulse Input Frequency	0-200 kHz	
Minimal Pulse Width	2.5 μs	
Minimal Direction Setup	5.0 μs	
Isolation Resistance	500mΩ	
Connector P1 Functions	PUL+	Pulse signal: 5V or 24V signal (Switch S3 determines voltage), differential input. High input is 4-5V or 22-24V, Low input is 0-0.5 V. Minimum pulse width = 2.5 μs. Switch S3 factory default = 24V position. WARNING! If switch S3 is in the 5V position and 24V is applied, the drive will be damaged. DIR signal: 5V or 24V signal (Switch S3 determines voltage), differential input. High input is 4-5V or 22-24V, Low input is 0-0.5 V. Minimum pulse width = 2.5 μs. Direction Function: requires 5μs setup time. CW/CCW Function: see DIP switch SW14. WARNING! If switch S3 is in the 5V position and 24V is applied, the drive will be damaged. Enable signal: 5V or 24V signal (Switch S3 determines voltage), differential input. High input is 4-5V or 22-24V, Low input is 0-0.5 V. Minimum pulse width = 2.5 μs. Enable Function: Close (pull low) to disable the drive. WARNING! If switch S3 is in the 5V position and 24V is applied, the drive will be damaged.
	PUL-	
	DIR+	
	DIR-	
	ENA+	
	ENA-	
Fault and Brake Output Connector	ALM	Optional output connection. Maximum of 30V/100mA output, sinking or sourcing.
	BR	
	COM-	
Replacement Connectors	Incoming Power = DN-2PLUG; Motor Power = DN-4PLUG; I/O = 6-pin from STP-CON-4	
Cooling	Natural cooling or forced cooling	
Ambient Temperature	0°C to 65°C (32°F to 149°F)	
Humidity	40-90% relative humidity	
Operating Temperature	0°C to 50°C (32°F to 122°F)	
Vibration	10-50 Hz / 0.15 mm	
Storage Temperature	-20°C to 65°C (-4°F to 149°F)	
Self Test	Yes	
Configuration Cable	1.4.4-0409505-B3	
Weight	250g (8.8 oz)	250g (8.8 oz)

1 - Output current ranges are for software settings which allow for a wider current range than DIP switches.

Leadshine Series Drive Cables		
Optional Configuration Cable	Compatible With	Price
1.4.4-0409505-B3	EM542S, EM556S	\$5.50

Note: Configuration cable only required if using optional configuration software. Software configuration not necessary unless DIP switch settings and auto-tuning aren't sufficient for your application. Requires an RS232 port on your PC, or a USB to RS232 converter, like USB-RS232.



1.4.4-0409505-B3



Stepping Drives

EM542S, EM556S Dimensions

Dimensions = in [mm]

EM542S

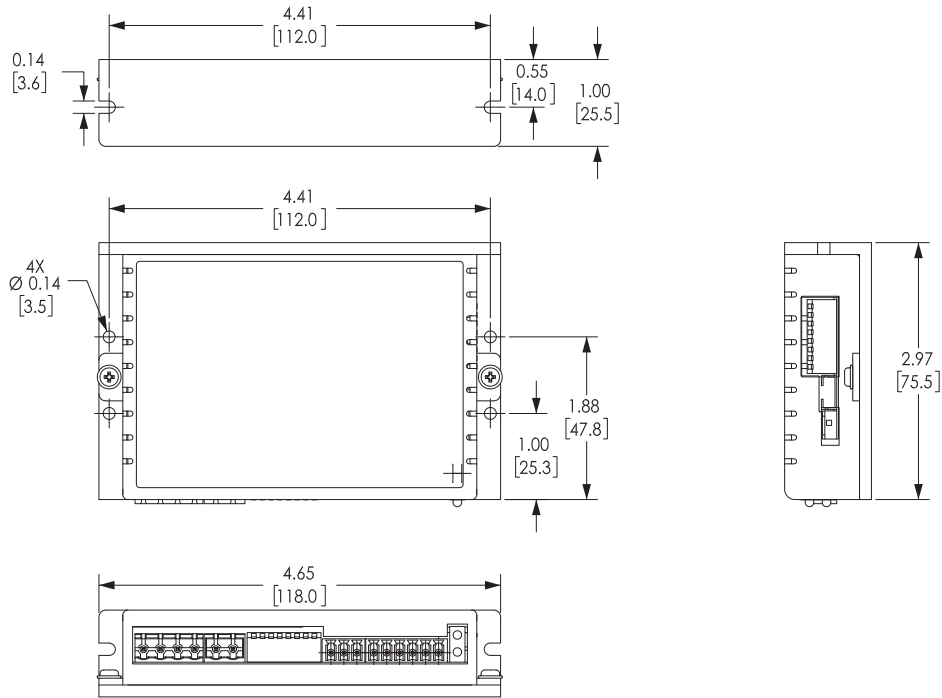

EM556S

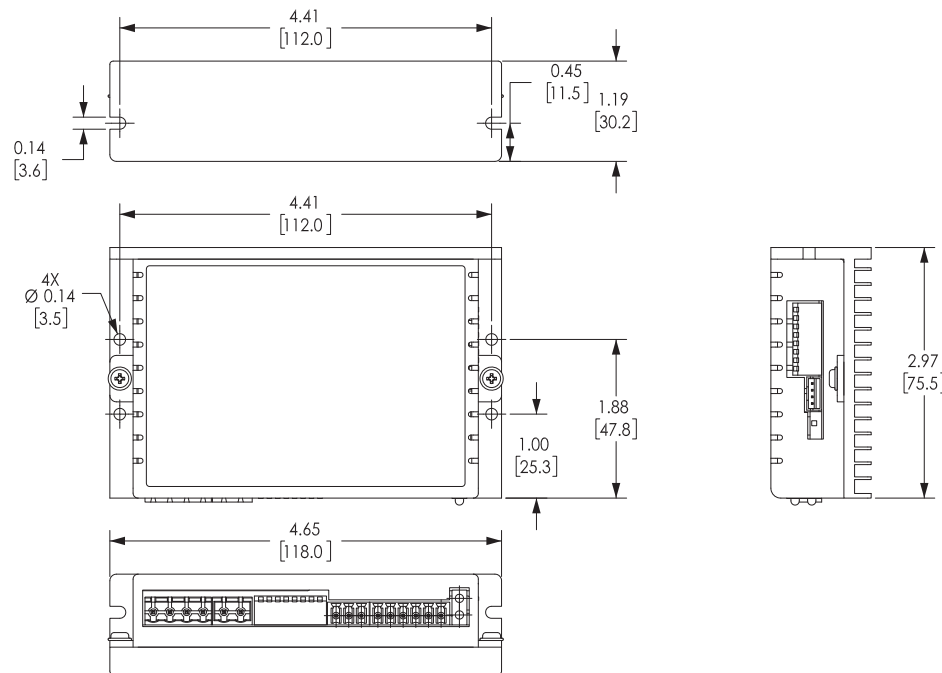



Stepping Drives

EM542S, EM556S Wiring

Note: These drives can accept Vcc of 24V or 5V. Set switch S3 before applying power.

EM542S, EM556S Connection to Open-Collector Signal

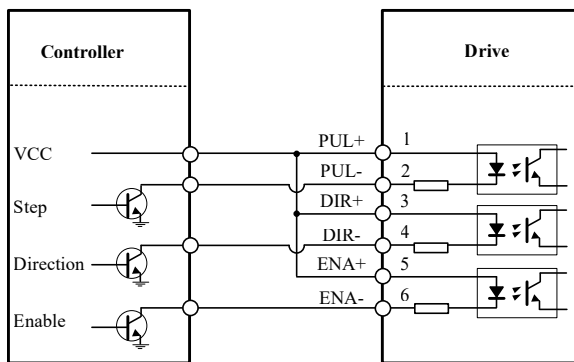

EM542S, EM556S Connection to PNP Signal

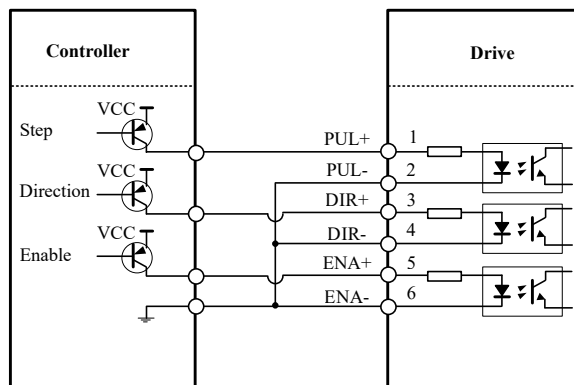

EM542S, EM556S Connection to Differential Signal; Typical Connection with Brake and Fault Outputs

