



igus XYZ Gantries Overview

Features:

- Maintenance and Lubrication free
- Base/Rail material: 6061-T6 Aluminum with hard anodize finish
- Carriage Block Bushing Material: Drylin® iglide®-J
- Drive Type: Belt Drive or Lead Screw
- Adjustable Carriage Block Clearance
- Stackable and easy to assemble
- T-slots enable limit switches to be positioned anywhere
- Up to 1,000 mm Stroke
- Motor mounts for SureServo servo motors and SureStep stepper motors



Configurations

igus linear actuators can be mounted in any orientation. However, overhead provides the best protection against contamination.

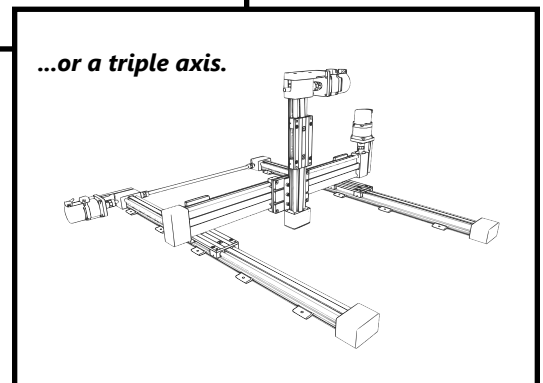
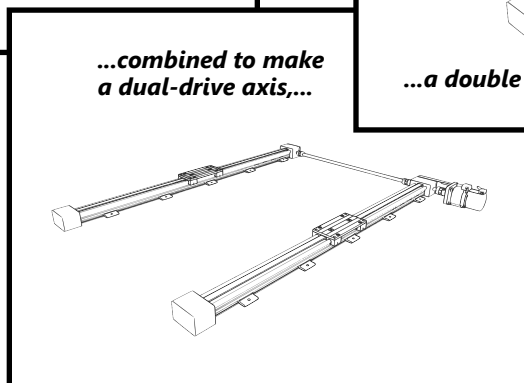
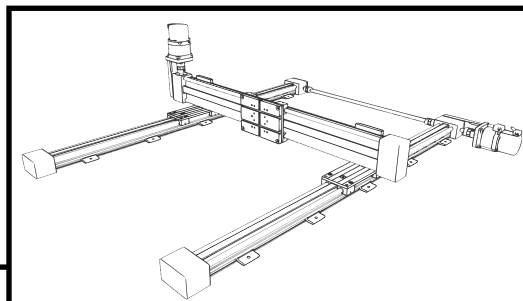
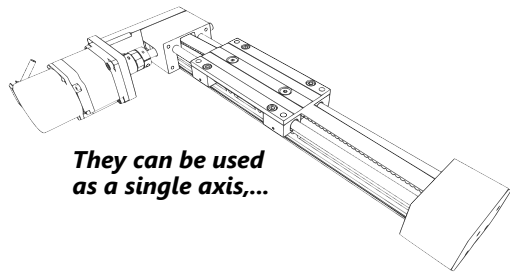



igus XYZ Gantries Overview

Rail Sizes

igus linear actuators are available in 2 rail sizes: W1040 and W1080.

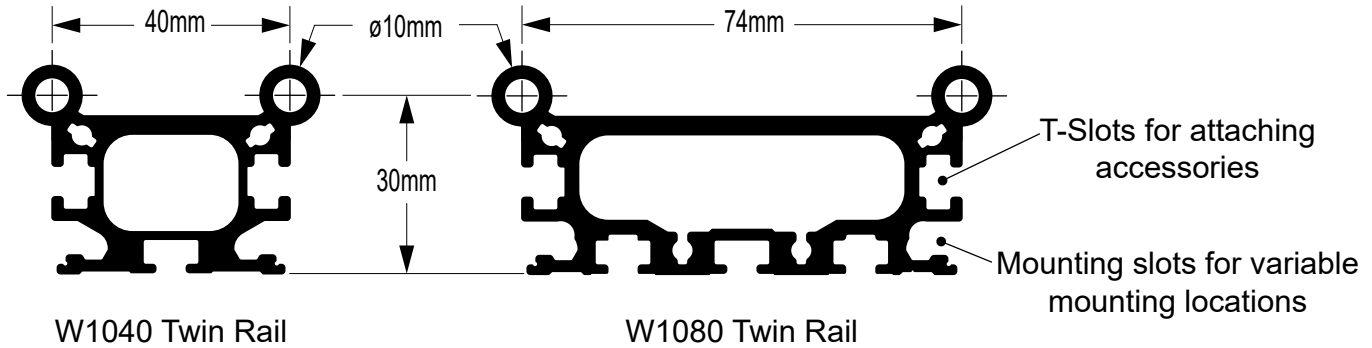

Drive Types

igus linear actuators are available in 2 drive types: ZLW (Belt Driven) and SAW (Lead Screw Driven).



ZLW1040S-2
(Belt Driven)

ZLW1040 & ZLW1080

- Belt Drive
- Max Linear Speed: 1.5 m/s [4.92 ft/s]
- Max Stroke: 1000mm
- Available Accessories
 - Servo Motor Brackets
 - Stepper Motor Brackets
 - XY Plate
 - YZ Plate
 - Dual X connecting Drive Shaft
 - Sensor Bracket
 - Replacement Carriage Block Liners



SAW1040-2-B
(Lead Screw Driven)

SAW1040 & SAW1080

- Lead Screw Drive
- Max Linear Speed: 0.15 m/s [0.49 ft/s]
- Max Stroke: 750mm
- Available Accessories
 - Servo Motor Brackets
 - Stepper Motor Brackets
 - XY Plate
 - YZ Plate
 - Sensor Bracket
 - Replacement Carriage Block Liners
 - Replacement Lead Nut

igus XYZ Gantries

ZLW Series (Belt Driven)

- Rail Material: 6061-T6 Aluminum, with Hard Anodize coating
- Carriage Block Bearing Material: iglide® J
- Belt Material: Polyurethane with steel cords, AT5 x 16mm wide
- ZLW1040 has Dual Input shafts, Ø10 mm
- ZLW1080 has Single Input shaft, Ø10 mm
- Adjustable clearance carriage blocks
- 8 T-slot nuts pre-installed, M5-0.8
- Mounting Clamps included



ZLW1040S-2

ZLW1080S-2

ZLW Series Linear Actuators (Belt Driven)											
Part Number	Price	Stroke (mm)	Mass (kg)	Backlash (in [mm])	Efficiency	Pitch (in/rev [mm/rev])	Max Linear Speed (ft/sec [m/sec])	Linear Position Accuracy (in [mm])	Linear Position Repeatability (in [mm])	Idle Torque (Nm)	Drawing Links
ZLW1040S-10	\$500.00	1,000	1.8	0.008 [0.2]	83%	2.76 [70]	4.92 [1.5]	0.008 [0.2]	0.008 [0.2]	0.3	PDF
ZLW1040S-2	\$422.00	200	1.54								PDF
ZLW1040S-3	\$450.00	300	1.68								PDF
ZLW1040S-4	\$476.00	400	1.82								PDF
ZLW1040S-5	\$450.00	500	1.96								PDF
ZLW1040S-6	\$465.00	600	2.24								PDF
ZLW1040S-8	\$480.00	800	2.52								PDF
ZLW1080S-10	\$665.00	1,000	1.05								0.008 [0.2]
ZLW1080S-2	\$620.00	200	2.01	PDF							
ZLW1080S-3	\$630.00	300	2.22	PDF							
ZLW1080S-4	\$635.00	400	2.43	PDF							
ZLW1080S-5	\$640.00	500	2.64	PDF							
ZLW1080S-6	\$650.00	600	3.06	PDF							
ZLW1080S-8	\$660.00	800	3.48	PDF							

ZLW Series Linear Actuators (Belt Driven) Load Ratings		
Part Number	ZLW1040S-xx	ZLW1080S-xx
Dynamic Load Rating, C (lbf [N])	112.41 [500]	
Static Load Rating, C_o (lbf [N])	1079.14 [4800]	
Reverse Static Load Rating, $-C_o$ (lbf [N])	224.82 [1000]	
Lateral Load Rating, L_T (lbf [N])	1079.14 [4800]	
Axial Load Rating, L_A (lbf [N])	16.86 [75]	
Pitch Moment Rating, M_P (lb-ft [N-m])	213.86 [290]	
Yaw Moment Rating, M_Y (lb-ft [N-m])	125.37 [170]	213.86 [290]
Roll Moment Rating, M_R (lb-ft [N-m])	70.8 [96]	131.27 [178]

Note: The end blocks should not be used as a mechanical stop. A buffer distance of 1 motor shaft revolution is recommended.

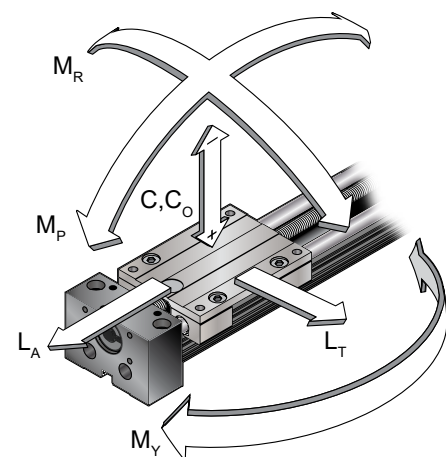

igus XYZ Gantries

SAW Series (Lead Screw Driven)

- Rail Material: 6061-T6 Aluminum, with Hard Anodize coating
- Carriage Block Bearing Material: iglide® J
- Lead Screw Material: 300 series Stainless Steel
- Lead Nut Material: iglide® J
- Adjustable clearance carriage blocks
- 8 T-slot nuts pre-installed, M5-0.8
- Mounting Clamps included



SAW1040-2-B

SAW1080-2-A

SAW Series Linear Actuators (Lead Screw Driven)											
Part Number	Price	Stroke (mm)	Mass (kg)	Backlash (in [mm])	Efficiency	Pitch (in/rev [mm/rev])	Max Linear Speed (ft/sec [m/sec])	Linear Position Accuracy (in [mm])	Linear Position Repeatability (in [mm])	Idle Torque (Nm)	Drawing Links
SAW1040-05-B	\$355.00	50	1.1	0.004 [0.1]	67%	0.98 [25]	1.15 [0.35]	0.004 [0.1]	0.004 [0.1]	0.2	PDF
SAW1040-1.5-B	\$370.00	150	1.2				1.31 [0.4]				PDF
SAW1040-1-B	\$360.00	100	1.15				0.49 [0.15]				PDF
SAW1040-2-B	\$375.00	200	1.3				PDF				
SAW1040-3-B	\$385.00	300	2.9				PDF				
SAW1080-1.5-A	\$638.00	150	3.1	0.004 [0.1]	67%	0.98 [25]	0.49 [0.15]	0.004 [0.1]	0.004 [0.1]	0.3	PDF
SAW1080-1-A	\$630.00	100	3								PDF
SAW1080-2-A	\$637.00	200	3.3								PDF
SAW1080-3-A	\$651.00	300	3.5								PDF
SAW1080-4-A	\$675.00	400	3.7								PDF
SAW1080-5-A	\$700.00	500	3.9								PDF
SAW1080-6-A	\$725.00	600	4.1								PDF
SAW1080-7.5-A	\$750.00	750	4.5								PDF

SAW Series Linear Actuators (Lead Screw Driven) Load Ratings		
Part Number	SAW1080-xx	SAW1040-xx
Dynamic Load Rating, C (lbf [N])	168.62 [750]	
Static Load Rating, C_o (lbf [N])	1079.14 [4800]	
Reverse Static Load Rating, $-C_o$ (lbf [N])	224.82 [1000]	
Lateral Load Rating, L_T (lbf [N])	1079.14 [4800]	
Axial Load Rating, L_A (lbf [N])	44.96 [200]	56.21 [250]
Pitch Moment Rating, M_P (lb-ft [N-m])	213.86 [290]	125.37 [170]
Yaw Moment Rating, M_Y (lb-ft [N-m])	213.86 [290]	125.37 [170]
Roll Moment Rating, M_R (lb-ft [N-m])	131.27 [178]	70.8 [96]

Note: The end blocks should not be used as a mechanical stop. A buffer distance of 1 motor shaft revolution is recommended.

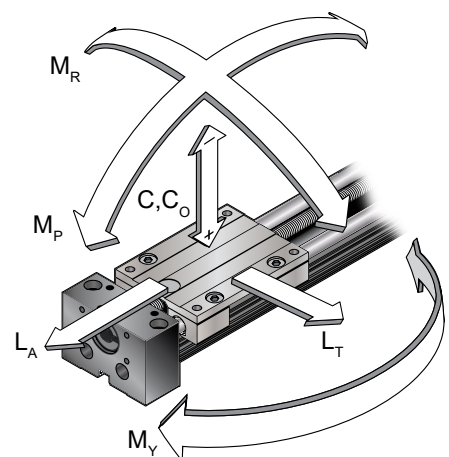

Motor Brackets

- Material: Aluminum
- Open frame for ease of assembly
- Available sizes for Stepper and Server motors

igus ZLW Motor Brackets					
Part Number	Price	Fits Motor	Recommended ADC Coupling Parts*		Drawing Links
			1040	1080	
STP17-ZLW	\$145.00	NEMA 17 stepper motors	SJCA-30C-5 SJCA-30C-10 SJC-30-RD-SLEEVE		PDF
STP23-ZLW	\$145.00	NEMA 23 stepper motors	SJCA-30C-6.35 SJCA-30C-10 SJC-30-RD-SLEEVE		PDF
SVL201-ZLW	\$175.00	SVL-201 SVL-201B SV2L-201B SV2L-201N	SJCA-30C-8 SJCA-30C-10 SJC-30-RD-SLEEVE		PDF
SVL202-ZLW	\$250.00	SVL-202 SVL-202B SV2L-202B SV2L-202N	SJCA-30C-14 SJCA-30C-10 SJC-30-RD-SLEEVE		PDF

Includes Mounting Hardware.

*Drive coupling parts sold separately. 2 coupling jaws and 1 spider required for complete coupling subassembly.



SVL201-ZLW

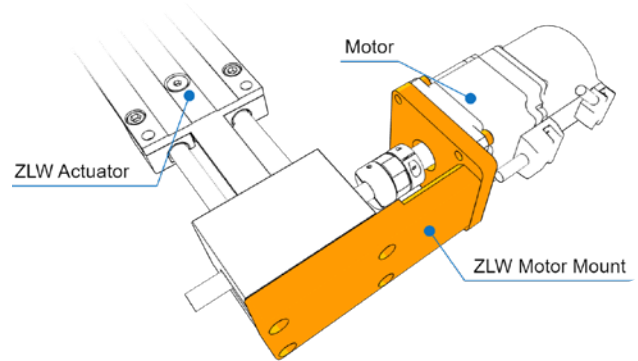

igus SAW Motor Brackets					
Part Number	Price	Fits Motor	Recommended ADC Coupling Parts*		Drawing Links
			1040	1080	
STP17-SAW	\$115.00	NEMA 17 stepper motors	SJCA-30C-5 SJCA-30C-10 SJC-30-RD-SLEEVE	SJCA-30C-5 SJCA-30C-8 SJC-30-RD-SLEEVE	PDF
STP23-SAW	\$115.00	NEMA 23 stepper motors	SJCA-30C-6.35 SJCA-30C-10 SJC-30-RD-SLEEVE	SJCA-30C-6.35 SJCA-30C-8 SJC-30-RD-SLEEVE	PDF
SVL201-SAW	\$140.00	SVL-201 SVL-201B SV2L-201B SV2L-201N	SJCA-30C-8 SJCA-30C-10 SJC-30-RD-SLEEVE	SJCA-30C-8 (x2) SJC-30-RD-SLEEVE	PDF
SVL202-SAW	\$125.00	SVL-202 SVL-202B SV2L-202B SV2L-202N	SJCA-30C-10 SJCA-30C-14 SJC-30-RD-SLEEVE	SJCA-30C-14 SJCA-30C-8 SJC-30-RD-SLEEVE	PDF

Includes Mounting Hardware.

*Drive coupling parts sold separately. 2 coupling jaws and 1 spider required for complete coupling subassembly.



SVL201-SAW

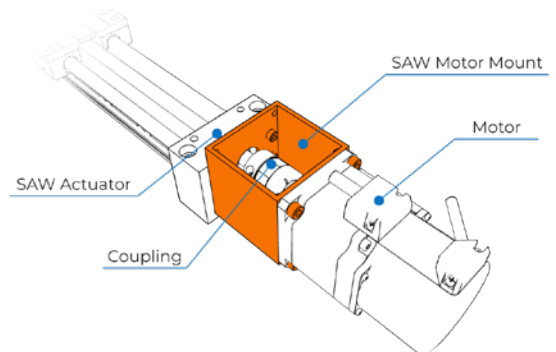

Mounting Brackets

- Material: Aluminum
- Mounts directly to Carriage Plate

igus Mounting Brackets					
Part Number	Price	Description	Holds Linear Actuator	Fits Linear Actuator Carriage Plate	Drawing Links
A-SWY108003150	\$136.00	Y or Z Adapter Plate (Qty. 2)	ZLW1040 and SAW1040	ZLW1080 and SAW1080 series actuators.	PDF
A-AK-0026	\$155.00	Y Mounting Bracket (Qty. 2)	ZLW080 and SAW1080	ZLW1040 and SAW1040 series actuators.	PDF
A-ZSY-104026	\$3.50	Mounting Clamp (Qty. 2)*	All ZLW and SAW series actuators.	All ZLW and SAW series actuators.	PDF

Includes Mounting Hardware.
*Mounts to Y or Z Adapter Plate.



A-SWY108003150



A-AK-0026



A-ZSY-104026

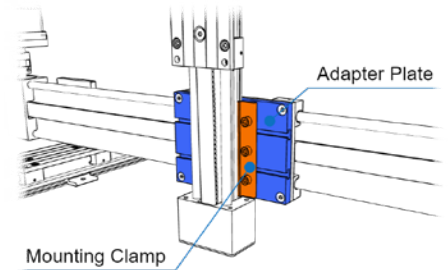
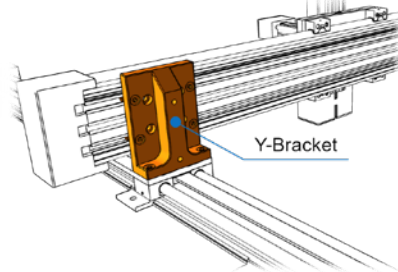
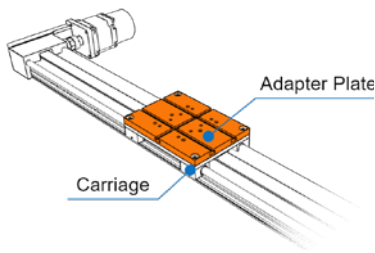



igus XYZ Gantries

Accessories

igus Accessories							
Part Number	Price	Description	Material	For Use With	Qty	Photo	Drawing Links
<u>A-AWM-10-1000</u>	\$33.00	Drylin R Series Shaft: round connecting, 10mm diameter, 1000mm length	6060/6061 aluminum	All ZLW series actuators	1		<u>PDF</u>
<u>A-AWM-10-500</u>	\$15.00	Drylin R Series Shaft: round connecting, 10mm diameter, 500mm length	6060/6061 aluminum	All ZLW series actuators	1		<u>PDF</u>
<u>A-KSTM-10</u>	\$6.00	Igubal K Series Mounted Spherical Bearing: 10mm inside diameter, pillow block	Ball: Type L280 polymer Housing:	Drylin R series 10mm shafts	1		<u>PDF</u>
<u>A-JUME-01-10</u>	\$4.50	Bearing Liner: for ZLW1040 and ZLW1080 series actuators	iglide® J	ZLW1040 and ZLW1080 series actuators	4		N/A
<u>A-NOR-20634</u>	\$2.50	M5 Slot Nut: for all ZLW and SAW series actuators	zinc plated steel	All ZLW and SAW series actuators	8		<u>PDF</u>
<u>IGUS-SENSBKT</u>	\$25.00	Sensor Bracket: for all ZLW and SAW series actuators	anodized aluminum	All ZLW and SAW series actuators Compatible Sensors: <u>P8-AN-2A</u> , <u>P8-AP-2F</u> , <u>P8-CP-2E</u>	1		<u>PDF</u>
<u>NUT1040-25</u>	\$27.00	Lead Nut: for SAW1040 series actuators	iglide® J	SAW1040 series actuators	1		N/A
<u>NUT1080-25</u>	\$65.00	Lead Nut: for SAW1080 series actuators	iglide® J	SAW1080 series actuators	1		N/A

Includes Mounting Hardware.

