

# DL205 High-Speed Counter I/O Module



## Overview

The High-Speed Counter I/O (CTRIO) modules are designed to accept high-speed pulse-type input signals for counting or timing applications, and is designed to provide high-speed pulse-type output signals for stepper motor control, monitoring, alarm or other discrete control functions. The H2-CTRIO2 module offers great flexibility for applications that call for precise counting or timing, based on an input event or for high-speed control output applications.

The CTRIO modules have their own microprocessor and operates asynchronously with respect to the PLC/Controller. This means that the on-board outputs respond in real time to incoming signals so there is no delay waiting for the PLC/Controller to scan I/O.

The H2-CTRIO2 module is designed to work with incremental encoders or other field devices that send pulse outputs.

## H2-CTRIO2 features

The H2-CTRIO2 module offers the following I/O features:

- Eight DC sink/source inputs, 9-30 VDC
- Four isolated sink/source DC outputs, 5-36 VDC, 1A per point

### Inputs supported:

- Two quadrature encoders up to 250 kHz (H2-CTRIO2), or 4 single channel counters up to 250 kHz (H2-CTRIO2) using module terminals Ch1A, Ch1B, Ch2A and Ch2B
- High-speed edge timers, dual edge timers, pulse catch, count reset, count inhibit or count capture or home search limits using module terminals Ch1C, Ch1D, Ch2C or Ch2D

### Outputs supported:

- Four independently configurable high-speed discrete outputs or 2 channels pulse output control (H2-CTRIO2: 20Hz - 250kHz per channel)
- Pulse and direction or cw/ccw pulses supported for pulse output control
- Raw control of a discrete output directly from user control program

## Typical applications

- High-speed cut-to-length operations using encoder input
- Pick-and-place or indexing functions for controlling a stepper or servo drive
- Dynamic registration for web material control
- Accurate frequency counting for speed control with onboard scaling
- PLS (Programmable Limit Switch) functions for high-speed packaging, gluing, or labeling
- Sub 10 usec pulse-catch capability for high-speed product detection
- Functions for level or flow

## Supported systems

Multiple CTRIO modules can reside in the same base provided that the backplane power budget is adequate. Depending which CPU/interface module is used, there may be I/O base slot restrictions for the CTRIO module. Refer to the CTRIO High-Speed Counter Manual (HX-CTRIO-M) for I/O slot restrictions.

### DirectLOGIC DL205 PLC

You can use the H2-CTRIO2 module with the [D2-262](#) CPU (It is not supported in local expansion bases).

### PC-based Ethernet I/O control systems

The H2-CTRIO2 module can be used in PC-based control systems using the H2-EBC100 interface module.

### ERM to EBC systems

The H2-CTRIO2 module is supported in [H2-EBC100](#) Servers in H\*-ERM(100) systems. This includes the supported DL205 CPUs. The CTRIO module consumes 96 inputs and 96 outputs when used in ERM/EBC expansion bases.

## Software Configuration

All scaling and configuration is done via CTRIO Workbench, a Windows software utility program. This eliminates the need for PLC ladder programming or other interface device programming to configure the module.

CTRIO Workbench main configuration screen

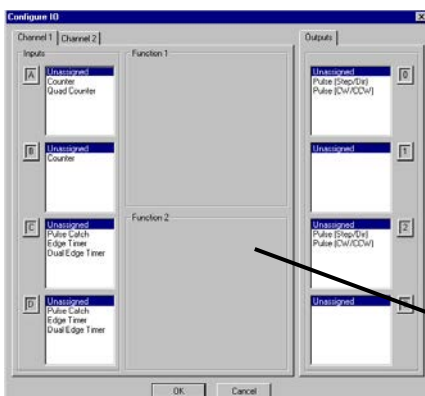
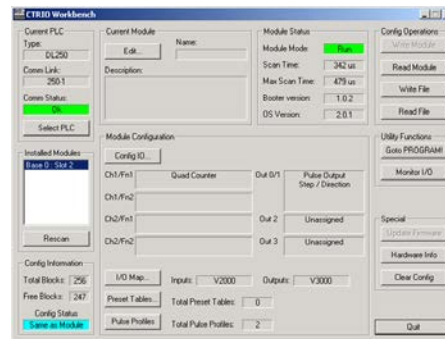

**Note:** CTRIO Workbench Version 2.2.0 is required to use [H2-CTRIO2](#).

Use Configure I/O dialog to assign the CTRIO input and output functions

# DL205 High-Speed Counter

## I/O Specifications

General	
<b>pulse</b>	H2-CTRIO2
<b>Module Type</b>	Intelligent
<b>Modules Per Base</b>	Limited only by power consumption
<b>I/O Points Used</b>	None, I/O map directly in PLC V-memory or PC control access
<b>Field Wiring Connector</b>	Standard removable terminal block
<b>Internal Power Consumption</b>	275 mA Max at +5V from Base Power Supply, Maximum of 6 Watts (All I/O in ON State at Max Voltage/Current)
<b>Operating Environment</b>	32°F to 140°F (0°C to 60°C), Humidity (non-condensing) 5% to 95%
<b>Manufacturer</b>	Host Automation Products, L.L.C.
<b>Isolation</b>	1500V I/O to Logic 1000V among Input Channels and All Outputs

H2-CTRIO2 Output Specifications			
<b>Module</b>	H2-CTRIO2		
<b>Outputs</b>	4 pts, independently isolated, current sourcing or sinking FET Outputs: open drain and source with floating gate drive		
<b>Voltage Range</b>	5–36 VDC		
<b>Maximum Voltage</b>	36VDC		
<b>Output clamp Voltage</b>	60VDC		
<b>Maximum Load Current</b>	1.0 A at 23°C 0.5 A at 60°C		
<b>Maximum Load Voltage</b>	36VDC		
<b>Maximum Leakage Current</b>	100µA		
<b>Inrush Current</b>	2A for 10ms		
<b>OFF to ON Response</b>	Less than 1 µsec		
<b>ON to OFF Response</b>	Less than 1 µsec		
<b>ON State V Drop</b>	0.45 V max.		
<b>External Power Supply</b>	For loop power only, not required for internal module function*		
<b>Overcurrent Protection</b>	15A max		
<b>Thermal Shutdown</b>	Tjunction = 150°C		
<b>Overtemperature Reset</b>	Tjunction = 130°C		
<b>Duty Cycle Range</b>	1% to 99% in 1% increments (default = 50%)		
<b>Configurable Presets</b>	a) each output can be assigned one preset, or b) each output can be assigned one table of presets, one table can contain max. 128 presets, max. predefined tables = 255		
<b>Maximum Output Frequency</b>	Velocity Mode	65 kHz	
	Run to Limit Mode		
	Run to Position Mode		
	Trapezoid		
	S-Curve		
	Symmetrical S-Curve		
	Dynamic Positioning		
	Home Search		
	Free Form		250 kHz
	Dynamic Velocity		
Dynamic Positioning Plus			
Trapezoid Plus			
Trapezoid with Limits			

\* User supplied power source required for stepper drive configuration.

H2-CTRIO2 Input Specifications	
<b>Module</b>	H2-CTRIO2
<b>Inputs</b>	8 pts sink/source 250kHz max.
<b>Minimum Pulse Width</b>	0.5 µsec
<b>Input Voltage Range</b>	9-30 VDC
<b>Maximum Voltage</b>	30VDC
<b>Input Voltage Protection</b>	Zener Clamped at 33VDC
<b>Rated Input Current</b>	8mA typical, 12mA maximum
<b>Minimum ON Voltage</b>	9.0 VDC
<b>Maximum OFF Voltage</b>	2.0 VDC
<b>Minimum ON Current</b>	5.0 mA (9VDC required to guarantee ON state)
<b>Maximum OFF Current</b>	2.0 mA
<b>OFF to ON Response</b>	Less than 0.5 µsec
<b>ON to OFF Response</b>	Less than 0.5 µsec

H2-CTRIO2 Input Resources	
<b>Counter/Timer</b>	4, (2 per 4 input channel group)
<b>Resource Options</b>	1X, 2X, or 4X Quadrature, Up or Down Counter, Edge Timer, Dual Edge Timer, Input Pulse Catch, Reset, Inhibit, Capture
<b>Timer Range / Resolution</b>	4.2 billion (32 bits); 1 µsec
<b>Counter Range</b>	±2.1 billion (32 bits or 31 bits + sign bit)

H2-CTRIO2 Output Resources	
<b>Module</b>	H2-CTRIO2
<b>Pulse output / Discrete outputs</b>	Pulse outputs: 2 channels (2 outputs each channel; 20Hz-250kHz) Discrete outputs: 4 pts.
<b>Resource Options</b>	Pulse outputs: pulse/direction or cw/ccw
	Output Profiles: Trapezoid S-Curve Symmetrical S-Curve Dynamic Positioning Dynamic Velocity Home Search Free Form Dynamic Positioning Plus Trapezoid Plus Trapezoid w/Limits Velocity Mode Run to Limit Mode Run to Position Mode
	Discrete outputs: 4 configurable for set, reset, pulse on, pulse off, toggle, reset count functions (assigned to respond to Timer/Counter input functions)
	Raw mode: Direct access to discrete output from user application program
<b>Target Position Range</b>	±2.1 billion (32 bits or 31 bits + sign bit)

# DL205 High-Speed Counter

## Status Indicators

H2-CTRIO2 LED Descriptions	
<b>OK</b>	Module OK
<b>ER</b>	User Program Error
<b>1A</b>	Channel 1 Status
<b>2A</b>	Channel 2 Status
<b>0-3</b>	Output Status

H2-CTRIO2 LED Diagnostic Definitions		
LED OK	LED ER	Description
Blinking	Blinking	Boot Mode - Used for Field OS Upgrades
Blinking	OFF	Program Mode
OFF	Blinking	Module Self-Diagnostic Failure (Blinks may be coded by counts)
OFF	ON	Module Error Due to Watchdog Timeout
OFF	OFF	No Power to Module
ON	OFF	RUN Mode

H2-CTRIO2 LED Diagnostic Definition	
1A/2A	
Blinking 7 times per second	Input is configured as Counter and is changing
Following state of input	Input is not configured as counter
0-3	
Follow actual output state: ON = output is passing current	

## Installation and Wiring

The H2-CTRIO2 module has two independent input channels, each consisting of 4 optically isolated input points (pts. 1A-1D on common 1M and pts. 2A-2D on common 2M). The inputs can be wired to either sink or source current.

The module has 4 optically isolated output points (pts. Y0-Y3 with isolated commons C0-C3, respectively). The outputs must be wired so positive current flows into Cn terminal and then out of the Yn terminal (see the diagram on the following page).

Remember that the internal jumpers can be used to connect the input commons or outputs/output commons together.

The modules are configured, using CTRIO Workbench, to accommodate the user's application. The function of each input (counting, timing, reset, etc.) and output (pulse output, discrete output, etc.) is defined in the configuration of the module.

See the notes below for further details about power source considerations, circuit polarities, and field devices.

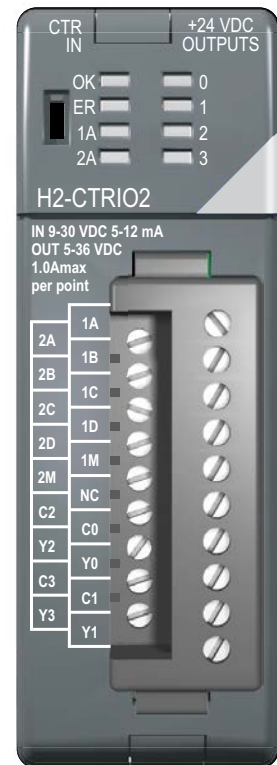

## Wiring Diagram

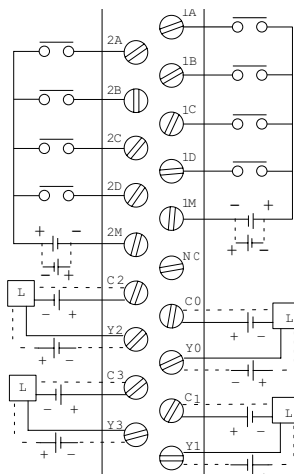

**Notes:**

- Inputs (1A, 1B, 1C, 1D and 2A, 2B, 2C, 2D) require user-provided 9-30 VDC power sources. Terminals 1M and 2M are the commons for Channel 1 and Channel 2 inputs. Maximum current consumption is 12mA per input point.
- Polarity of the input power sources can be reversed. Consideration must be given, however, to the polarity of the field device. Many field devices are designed for only one polarity and can be damaged if power wiring is reversed.
- Outputs have one polarity only and are powered by user-provided 5-36 VDC power sources. The maximum allowable current per output circuit is 1A.

# DL205 High-Speed Counter

## Solid-state Input Wiring Device

DC type field devices are configured to either sink or source current. This affects the wiring of the device to the CTRIO2 module. Refer to the sinking/sourcing appendix in this catalog for a complete explanation of sinking and sourcing concepts.

### NPN Field Device (sink)

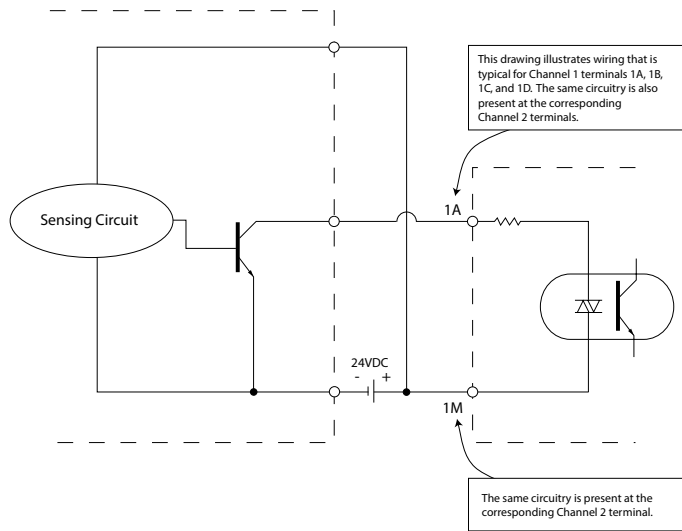

### PNP Field Device (source)

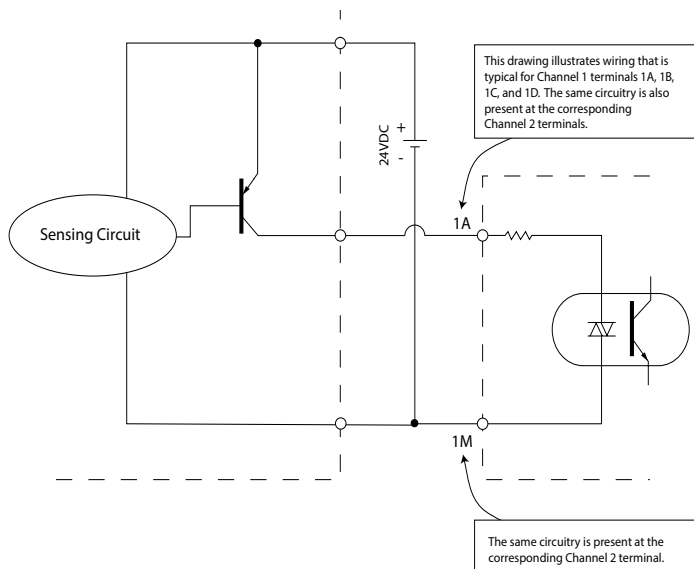

## Pulse Output Schematic

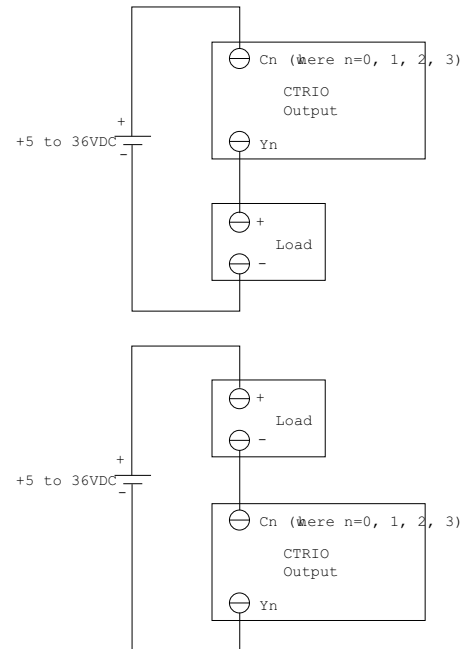

## Stepper/Servo Drive Wiring Example

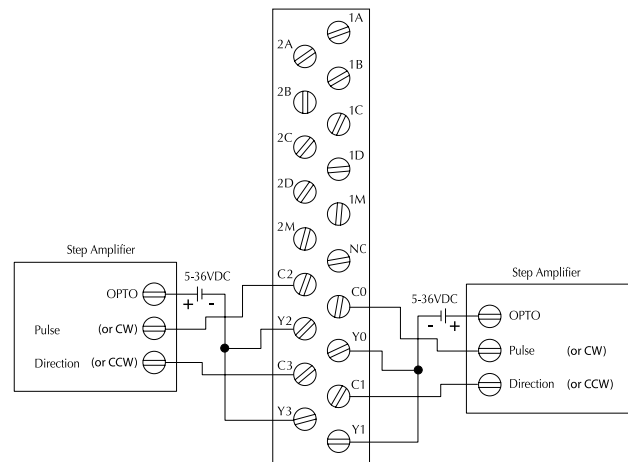

# DL205 High-Speed Counter

## Fill-in-the-blank configuration software

The CTRIO Workbench is the software utility used to configure the CTRIO modules and to scale signals to desired engineering units. Workbench also allows you to perform various other functions, such as switching between the CTRIO's Program mode and Run mode, monitoring I/O status and functions, and diagnostic control of module functions. The latest version of the CTRIO Workbench utility can be downloaded for free at Host Engineering's Web site: [www.hosteng.com](http://www.hosteng.com).

### CTRIO Workbench configure I/O setup

The Configure I/O dialog is the location where input and output functions are assigned to the module. The choice of input and output functions determines which options are available. The input function boxes prompt you with selections for supported functions. The Workbench software automatically disallows any unsupported configurations.



H2-CTRIO2

Configure I/O screen

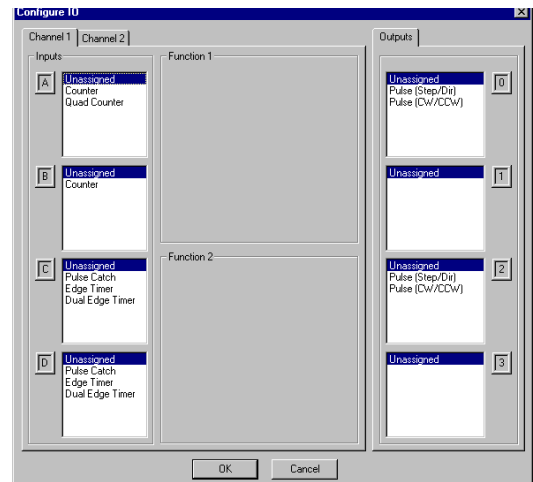
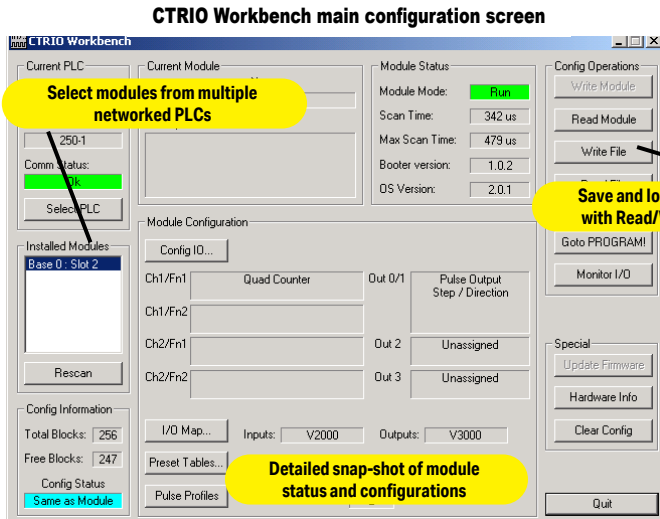

### CTRIO Workbench diagnostics and monitoring

The Monitor I/O dialog is accessible from the main Workbench dialog when the module is in Run Mode. This allows for a convenient way to test and debug your configuration prior to installation. The Monitor I/O dialog is divided into three functional areas: Input Functions, Output Functions and System Functions. The data displayed under the Input Functions tab includes all input Dword parameters, status bits and the current status of each configured input and output function. The fields displayed under the Output Functions tab includes all output (D)word parameters and configuration information that can be altered during runtime and the bits that indicate successful transfers or errors. The System Functions can be used to read from or write to the CTRIO's internal registers.

### CTRIO Workbench on-board scaling

Scaling raw signals to engineering units is accomplished using the Scaling Wizard. The Scaling Wizard options are different for the Counter functions as compared to the Timer functions. "Position" and "Rate" scaling are available when you select a Counter function. "Interval" scaling is available when you select a Timing function.

Monitor I/O screen

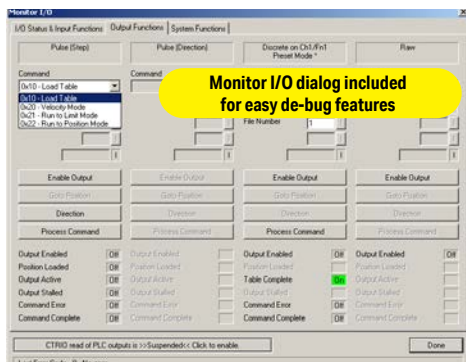

Scaling Wizard screen

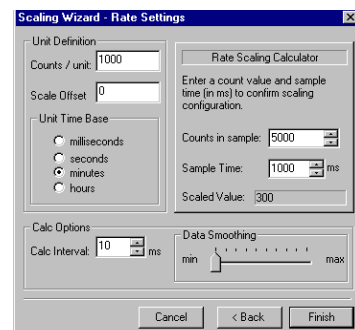



# DL205 High-Speed Counter

## High-speed input operations

The H2-CTRIO2 modules are capable of a wide variety of high-speed input and output operations, all within one module. With flexible 2-channel input and separate 2-channel output design, the H2-CTRIO2 modules can satisfy high-speed counting, timing, and pulse catch operations, along with high-speed discrete output or several profile choices of pulse output operations. Not all combinations of input functions and output functions are possible within the resources of the module, but the following examples are some of the most common applications for the CTRIO modules. Check out these examples and see how they relate to your high speed application needs.

### High-speed timing

The CTRIO2 modules can be configured for timing functions based on both count or rate. Using a common configuration of a proximity switch sensing the teeth on a gear, the module is able to calculate the velocity of the gear based on the rate it receives its counts. This value can be scaled within the module to the engineering units required for the application.

#### High-speed timing application

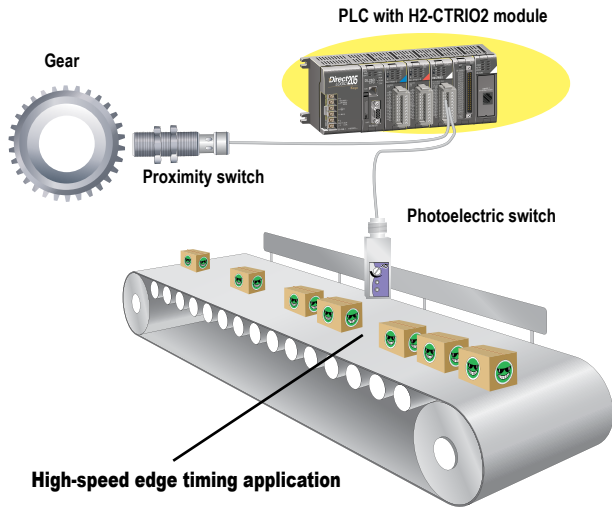

#### High-speed edge timing application

#### Using Configure I/O screen to configure H2-CTRIO2 for high-speed timing

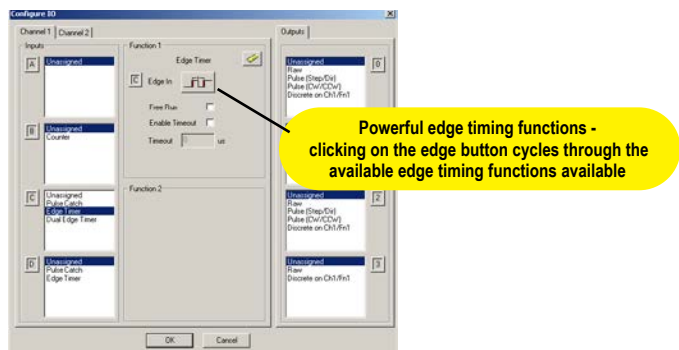

### High-speed counting

The CTRIO2 modules can be configured for counting functions with an encoder input (up to two quadrature encoders per module), with available connections for external reset, capture and inhibit signals. In a simple cut-to-length application as shown, the encoder provides an input position reference for the material to the module. The module's high-speed outputs are wired to the cutting device and to the clutch and/or braking device. When the count from the encoder is equal to a pre-programmed setpoint within the module, the high-speed outputs are activated to stop and cut the material to a repeatable fixed length. Additionally, the clutch/brake signal can be used as an inhibit signal so counts are not accumulated while the material is being cut.

#### High-speed cut-to-length application

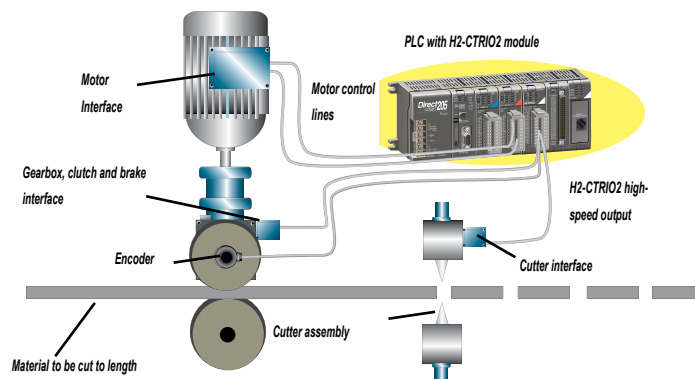

#### Using Configure I/O screen to configure CTRIO2 for high-speed counting

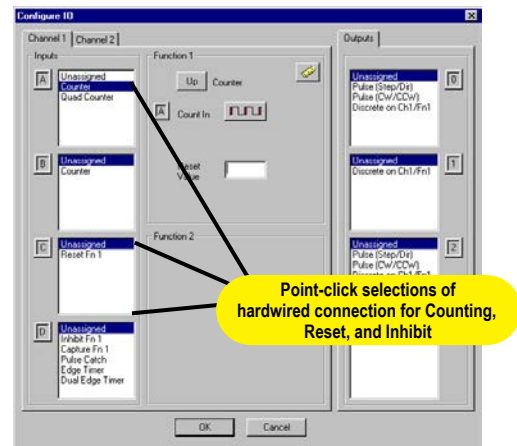

# DL205 High-Speed Counter

## Pulse output operations

### Using Edit Pulse Profile screen to select Trapezoid pulse output profile

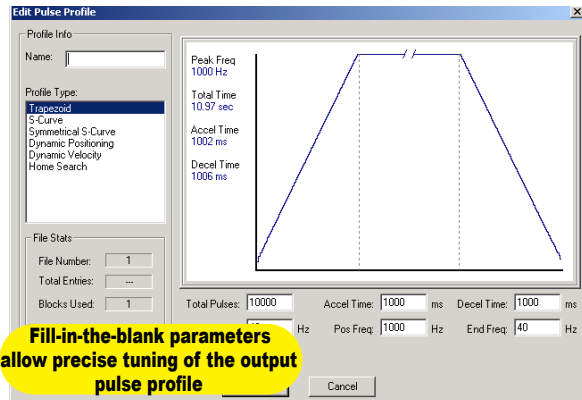

### Pulse output for stepper/servo control

The H2-CTRIO2 module is capable of multiple configurations for pulse output control, most often when connected to a stepper or servo drive system. The H2-CTRIO2 module can deliver a pulse output signal up to a maximum of 250kHz, along with support for pulse-and-direction or CW/CCW pulses. The available profile choices include Trapezoid, S-Curve, Symmetrical S-Curve, Dynamic Positioning, Dynamic Velocity, Home Search, Free Form, Dynamic Positioning Plus, Trapezoid Plus and Trapezoid w/Limits. All profiles can be easily configured using the CTRIO Workbench software with fill-in-the-blank parameter fields and a graphic representation of the selected profile. Three additional profiles are available that are completely controlled by the user program (no CTRIO Workbench profile is configured). They are Velocity Mode, Run to Limit Mode, and Run to Position Mode.

### Example application

In a simple rotary indexing application, as shown above, a fixed Trapezoid profile is chosen. For this application the H2-CTRIO2 module is wired to a stepper drive for pulse-and-direction. The requirement for this application is to provide a smooth movement of the rotary table to allow product to be filled into individual containers an equal distance apart. The predetermined number of pulses required for each movement is entered into the CTRIO Workbench as "Total Pulses" along with the Starting Frequency, Ending Frequency, and Positioning Frequency (speed after acceleration). The Acceleration and Deceleration parameters are entered in units of time, so no ramp-distance calculations are required. After all parameters are entered, a graphical representation of the configured profile is shown automatically. Once the configuration has been downloaded to the module, all that is needed from the PLC CPU is for the Enable Output signal to begin a movement.

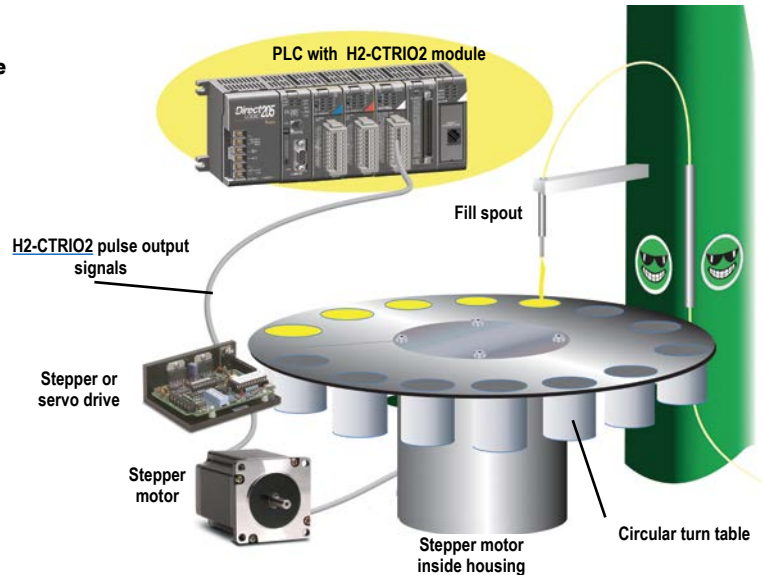

Rotary indexing liquid fill application

### Other common pulse output applications:

- S-Curve accel/decel profile for signaling a stepper or servo drive that needs a curved acceleration and deceleration profile, i.e. for diminishing any initial "jerk" upon movement of static products, boxes on conveyors, liquids in containers on an indexer, printing registrations, etc.
- Dynamic Positioning for any run-to-a-specific-position requirement, either by a pre-programmed count of an external high-speed discrete input wired to the module. This is popular in winding or web control with any dynamic registration mark or variable speed requirement.
- Home search routines to seek a home position based on H2-CTRIO2 discrete input limit(s).

### Example of S-Curve acceleration and deceleration pulse output profile

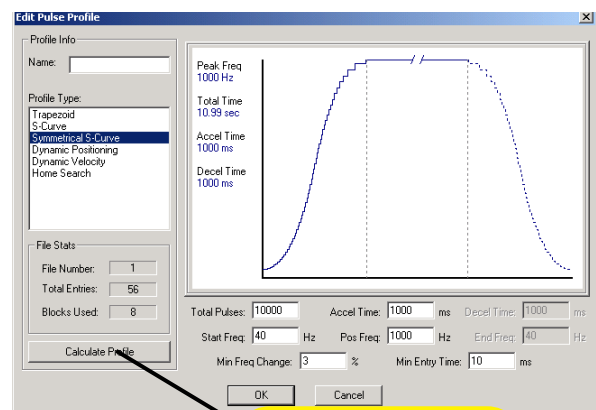

# DL205 High-Speed Counter

## Combining high-speed input and pulse output operations

Using CTRIO Workbench to configure the module for simultaneous high-speed input and high-speed pulse output operation

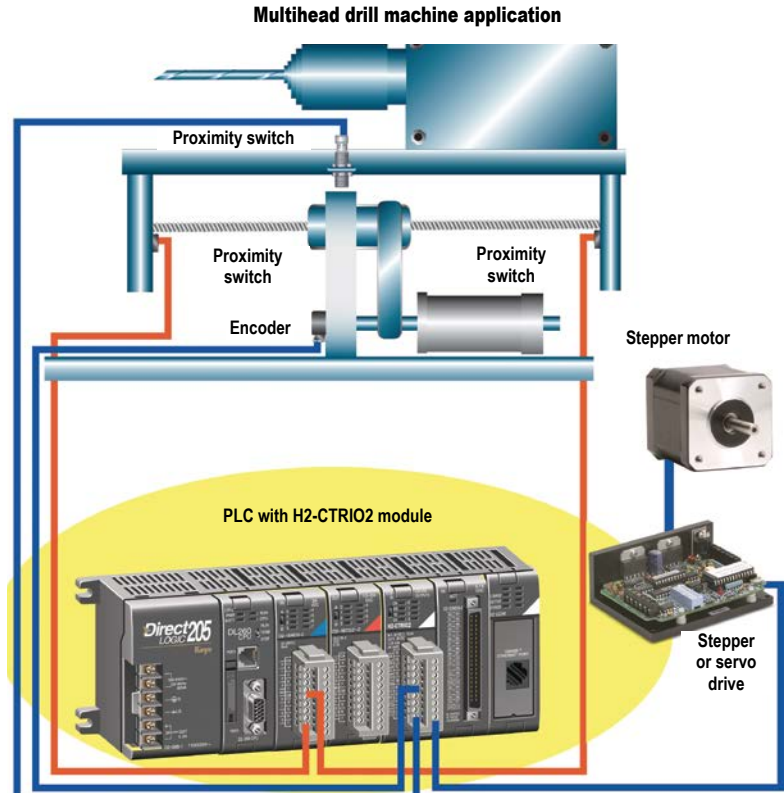
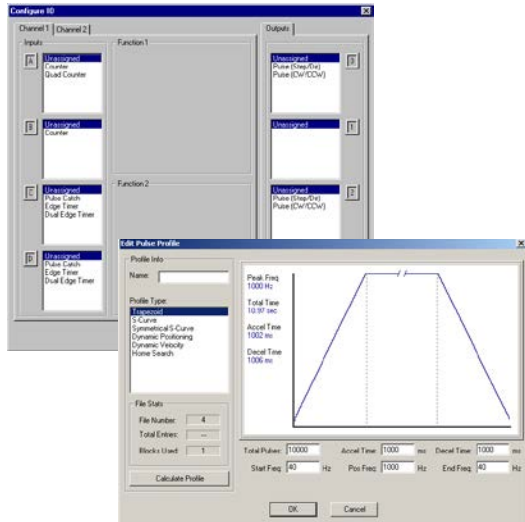

### Use Encoder for Position

Three profiles available only with the CTRIO2 offer the option to Use Encoder for Position. They are Dynamic Position Plus, Trapezoid Plus and Trapezoid w/ Limits. When Use Encoder for Position is enabled, the target positions are specified in units of the encoder and the move is complete when the encoder reaches that position, not when the output has finished generating a certain number of pulses. This functionality is useful for hitting a target position more accurately with a mechanical system that slips or has excessive lash.

### Example application

In the simple drill head application shown above, the H2-CTRIO2 pulse outputs are wired to a stepper or servo drive. The inputs are wired to an encoder attached to the lead screw on the movable portion of the drill head assembly. The CTRIO2 module outputs a pulse train to the drive that allows the motor to spin the lead screw, making the drill move forward into the passing material. The encoder monitors the speed and position of the drill head. Proximity switches at each end act as limit switches ensuring the drill head will not over-travel. A home sensor is positioned in the middle of the assembly which allows the PLC to reset the count.

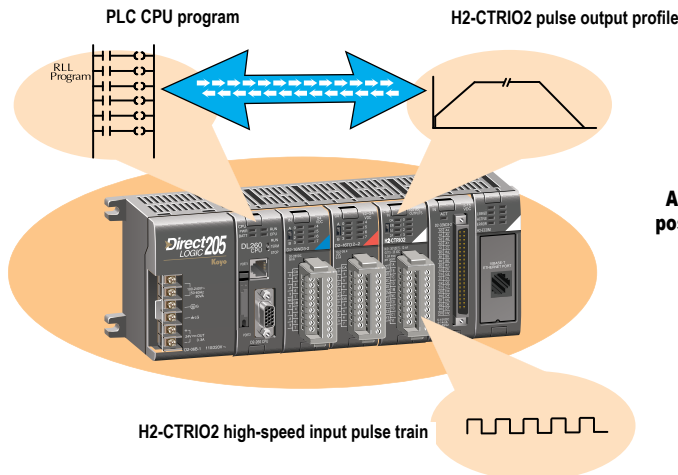

As shown in diagram on left, using an encoder to calculate the appropriate position for a move using H2-CTRIO2 is handled natively on-the-fly when "Use Encoder for Position" is enabled.





# Power Requirements

## These charts help determine your power requirements

This section shows the amount of power supplied by each of the base power supplies and the amount of power consumed by each DL205 device. The Power Consumed charts list how much INTERNAL power from each power source is required for the DL205 devices. Use this information when calculating the power budget for your system.

In addition to the internal power sources, the DL205 bases offer a 24 VDC auxiliary power supply with external power connections. This auxiliary power supply can power external devices.

## Use ZIPLinks to reduce power requirements

If your application requires a lot of relay outputs, consider using the ZIPLink AC or DC relay output modules. These modules can switch high current (10A) loads without putting a load on your base power budget. Refer to the Terminal Blocks and Wiring Solutions section in this catalog for more information.

This logo is placed next to the I/O modules that are supported by the ZIPLink connection systems. See the I/O module specifications at the end of this section.



Power Consumed		
Device	5V(mA)	24V Auxiliary
<b>Operator Interface</b>		
C-more Micro-Graphic	210	0

Power Supplied			
Device	Price	5V(mA)	24V Auxiliary
<b>Bases</b>			
D2-03B-1	\$200.00	2600	300
D2-03BDC1-1	\$249.00	2600	None
D2-04B-1	\$217.00	2600	300
D2-04BDC1-1	\$274.00	2600	None
D2-06B-1	\$268.00	2600	300

Power Consumed		
Device	5V(mA)	24V Auxiliary
<b>CPUs</b>		
D2-262	336	0
<b>DC Input Modules</b>		
D2-08ND3	50	0
D2-16ND3-2	100	0
D2-32ND3	25	0
D2-32ND3-2	25	0
<b>AC Input Modules</b>		
D2-08NA-1	50	0
D2-08NA-2	100	0
D2-16NA	100	0
<b>Input Simulator Module</b>		
F2-08SIM	50	0
<b>DC Output Modules</b>		
D2-04TD1	60	20
D2-08TD1	100	0
D2-08TD2	100	0
D2-16TD1-2	200	80
D2-16TD2-2	200	0
F2-16TD1P	70	50
F2-16TD2P	70	50
D2-32TD1	350	0
D2-32TD2	350	0
<b>AC Output Modules</b>		
D2-08TA	250	0
F2-08TA	250	0
D2-12TA	350	0
<b>Relay Output Modules</b>		
D2-04TRS	250	0
D2-08TR	250	0
F2-08TR(S)	670	0
D2-12TR	450	0
<b>Combination In/Out Module</b>		
D2-08CDR	200	0

Power Supplied			
Device	Price	5V(mA)	24V Auxiliary
<b>Bases</b>			
D2-06BDC1-1	\$304.00	2600	None
D2-06BDC2-1	\$279.00	2600	300
D2-09B-1	\$333.00	2600	300
D2-09BDC1-1	\$360.00	2600	None
D2-09BDC2-1	\$359.00	2600	300

Power Consumed		
Device	5V(mA)	24V Auxiliary
<b>Analog Modules</b>		
F2-04AD-1	100	5
F2-04AD-2	110	5
F2-08AD-1	100	5
F2-08AD-2	100	5
F2-02DA-1	40	60 (note 1)
F2-02DA-2	40	60
F2-02DAS-1	100	50 / channel
F2-02DAS-2	100	60 / channel
F2-08DA-1	30	50 (note 1)
F2-08DA-2	60	140
F2-4AD2DA	60	80 (note 1)
F2-8AD4DA-1	35	100 (note 1)
F2-8AD4DA-2	35	80 (note 1)
F2-04RTD	90	0
F2-04THM	110	60
<b>Specialty Modules</b>		
D2-CTRINT	50*	0
D2-CM / D2-EM	100/130	0
H2-CTRIO2	275	0
D2-DCM	300	0
H2-EBC100	300	0
H2-ECOM100	300	0
F2-CP128	235	0
<b>Remote I/O</b>		
H2-ERM100, (-F)	300, (-F: 450)	0
<b>Programming Devices</b>		
D2-HPP	200	0

\* Requires external 5VDC for outputs

Note 1: Add an additional 20 mA per output loop.



# Dimensions and Installation

Understanding the installation requirements for your DL205 system will help ensure that the DL205 products operate within their environmental and electrical limits.

## Plan for safety

This catalog should never be used as a replacement for the user manual. The user manual, D2-USER-M (downloadable online), contains important safety information that must be followed. The system installation should comply with all appropriate electrical codes and standards.

## Environmental specifications

The Environmental Specifications table at the right lists specifications that apply globally to the DL205 system (CPUs, bases, and I/O modules). Be sure that the DL205 system is operated within these environmental specifications.

## Base dimensions and mounting

Use the diagrams below to make sure the DL205 system can be installed in your application. To ensure proper airflow for cooling purposes, DL205 bases must be mounted horizontally. It is important to check these dimensions against the conditions required for your application. For example, it is recommended that approximately 3" of space is left in front PLC surface for ease of access and cable clearances. Also, check the installation guidelines for recommended cabinet clearances.

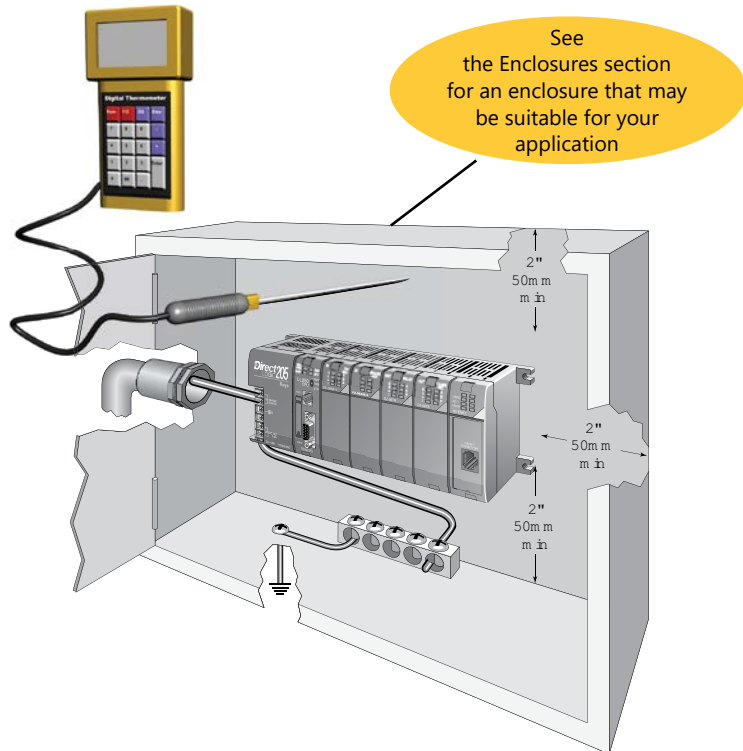

Environmental Specification	Rating
<b>Storage Temperature</b>	-4°F to 158°F (-20°C to 70°C)
<b>Ambient Operating Temperature</b>	32°F to 131°F (0°C to 55°C)
<b>Ambient Humidity</b>	30% to 95% relative humidity (non-condensing)
<b>Vibration Resistance</b>	MIL STD 810C, Method 514.2
<b>Shock Resistance</b>	MIL STD 810C, Method 516.2
<b>Noise Immunity</b>	NEMA (ICS3-304)
<b>Atmosphere</b>	No corrosive gases

Base	A	B	C	D
<b>D2-03B-1, D2-03BDC1-1</b>	6.77" 172mm	6.41" 163mm	5.8" 148mm	7.24" 184mm
<b>D2-04B-1, D2-04BDC1-1</b>	7.99" 203mm	7.63" 194mm	7.04" 179mm	8.46" 215mm
<b>D2-06B-1, D2-06BDC1-1, D2-06BDC2-1</b>	10.43" 265mm	10.07" 256mm	9.48" 241mm	10.90" 277mm
<b>D2-09B-1, D2-09BDC1-1, D2-09BDC2-1</b>	14.09" 358mm	13.74" 349mm	13.14" 334mm	14.56" 370mm

