

# GS/DURAPULSE Drives Accessories – Dynamic Braking Component Selection – GS3

## Braking Component Selection for GS3 DURApulse AC Drives

GS3 AC Drive Braking Component Selection												
Drive Voltage	Motor Power		125% Braking Torque @ 10% Duty cycle**							Max Braking Torque		
			AC Drive Model #	Braking Unit		Braking Resistor		Brake Torque (kg·m)	Total Brake Current (A)	Min Resistor Value (Ω)	Max Total Brake Current (A)	Peak Power (W)
	GS3-	Quantity		Part # GS-	Quantity	Part # GS-						
230V	1	0.7	21P0	0	n/a	1	21P0-BR	0.5	1.9	82	4.6	1.8
	2	1.5	22P0			1	22P0-BR	1.0	3.8	82	4.6	1.8
	3	2.2	23P0			1	23P0-BR	1.5	5.4	82	4.6	1.8
	5	3.7	25P0			1	25P0-BR***	2.5	9.5	33	11.5	4.4
	7.5	5.5	27P5			1	27P5-BR	3.7	12.7	30	12.7	4.8
	10	7.5	2010			1	2010-BR-ENC	5.1	19.0	20	19.0	7.2
	15	11	2015			1	2015-BR-ENC	7.5	27.9	13.6	27.9	10.6
	20	15	2020	1	2DBU	1	2020-BR-ENC	10.2	38.0*	10*	38.0*	14.4*
	25	18	2025	1	2DBU	1	2025-BR-ENC	12.2	47.5*	8*	47.5*	18.1*
	30	22	2030	1	2DBU	1	2030-BR-ENC	14.9	55.9*	6.8*	55.9*	21.2*
	40	30	2040	2	2DBU	2	2040-BR-ENC	20.3	38.0*	10*	38.0*	14.5*
	50	37	2050	2	2DBU	2	2050-BR-ENC	25.1	47.5*	8*	47.5*	18.1*
460V	1	0.7	41P0	0	n/a	1	41P0-BR	0.5	1.0	160	4.8	3.6
	2	1.5	42P0			1	42P0-BR	1.0	1.9	160	4.8	3.6
	3	2.2	43P0			1	43P0-BR	1.5	3.0	160	4.8	3.6
	5	3.7	45P0			1	45P0-BR	2.5	5.1	130	5.8	4.4
	7.5	5.5	47P5			1	47P5-BR	3.7	7.6	91	8.4	6.3
	10	7.5	4010			1	4010-BR	5.1	10.1	62	12.3	9.3
	15	11	4015			1	4015-BR-ENC	7.5	15.2	39	19.5	14.8
	20	15	4020	1	4DBU	1	4020-BR-ENC	10.2	19.0*	40*	19.0*	14.4*
	25	18	4025	1	4DBU	1	4025-BR-ENC	12.2	23.8*	32*	23.8*	18.1*
	30	22	4030	1	4DBU	1	4030-BR-ENC	14.9	27.9*	27.2*	27.9*	21.2*
	40	30	4040	1	4DBU	1	4040-BR-ENC	20.3	38.0*	20*	38.0*	28.9*
	50	40	4050	1	4DBU	1	4050-BR-ENC	25.1	47.5*	16*	47.5*	36.1*
	60	45	4060	1	4DBU	1	4060-BR-ENC	30.5	55.9*	13.6*	55.9*	42.5*
	75	55	4075	2	4DBU	2	4075-BR-ENC	37.2	38.0*	20*	38.0*	28.9*
100	75	4100	2	4DBU	2	4100-BR-ENC	50.8	55.9*	13.6*	55.9*	42.5*	

\* These values are per individual DBU, as seen between DBU terminals B1 and B2.  
 \*\* 10% Duty Cycle with maximum ON (braking) time of 10 seconds.  
 \*\*\* GS-25P0-BR can be also be used with SureServo AC Servo Drive # SVA-2040.

NOTE: For DURAPULSE GS3 series AC drives 20 hp and above, dynamic braking units must be used in conjunction with braking resistors.

# GS4 DURAPULSE Drives Accessories – Dynamic Braking Component Selection

## Dynamic Braking Components

Use the table below to find the appropriate braking resistor and braking unit (if applicable) for your GS4 series AC drive. For more information and installation instructions, please see the GS4 User Manual. All listed resistors are available for purchase at [www.automationdirect.com](http://www.automationdirect.com).

GS4 AC Drive Braking Component Selection																			
Drive Voltage	Motor Power (hp)	Drive Model	Drive Brake Capacity - Max Torque		Braking Unit		125% Braking Torque @ 10% Duty Cycle*												
			Min Resistor Value (Ω)	Max Total Brake Current (A)	Quantity	Part # GS-	Open Type Braking Resistor					NEMA1 Resistors with Thermal Switch							
							Part #	Quantity	Wiring Diagram	Brake Torque (kg·m)	Total Brake Current (A)	Part #	Qty.	Wiring Diagram	Total Brake Current (A)				
230V	1	GS4-21P0	63.3	6	-	n/a	GS-BR-080W200	1	A		0.5	1.9	BR-N1-240W150	1	A	2.6			
	2	GS4-22P0	47.5	8			GS-BR-200W091	1			1.0	4.2	BR-N1-280W50	1		7.8			
	3	GS4-23P0	38.0	10			GS-BR-300W070	1			1.5	5.4	BR-N1-800W25	1		15.6			
	5	GS4-25P0	19.0	20			GS-BR-400W040	1			2.5	9.5	BR-N1-800W18P0	1		21.7			
	7.5	GS4-27P5	14.6	26			GS-BR-1K0W020	1			3.7	19	BR-N1-1K1W15P0	1		26.0			
	10	GS4-2010	14.6	26			GS-BR-1K5W013	1			5.1	29	BR-N1-1K5W14P0	1		27.9			
	15	GS4-2015	12.6	28			GS-BR-1K0W4P3	2S			B	10.2	44	BR-N1-2K2W08P6		1	F	45.3	
	20	GS4-2020	8.3	46			GS-BR-1K0W4P3	2S				12.2		BR-N1-3K0W05P8		1			67.2
	25	GS4-2025	8.3	46			GS-BR-1K5W3P3	2S				14.9		58		BR-N1-1K6W10P0			2 (1/DBU)
	30	GS4-2030	5.8	66			Not offered					BR-N1-2K2W06P8	2 (1/DBU)	116*					
	40	GS4-2040	4.8*	80*			Not offered					BR-N1-3K6W06P8	2 (1/DBU)						
	50	GS4-2050	3.2*	120*			Not offered					BR-N1-3K6W06P8	2 (1/DBU)						
	60	GS4-2060	3.2*	120*			Not offered					BR-N1-2K2W06P8	3 (1/DBU)						
	75	GS4-2075	2.1*	180*			Not offered					BR-N1-2K2W06P8	4 (1/DBU)						
	100	GS4-2100	1.6*	240*			Not offered					BR-N1-240W200	1	4.0					
	460V	1	GS4-41P0	190			4	-	n/a	GS-BR-080W750	1	A		0.5	1	BR-N1-240W150	1	A	5.3
2		GS4-42P0	126.7	6	GS-BR-200W360	1	1			2.1	BR-N1-500W200			1	4.0				
3		GS4-43P0	108.6	7	GS-BR-300W250	1	1.5			3	BR-N1-500W130			1	6.1				
5		GS4-45P0	84.4	9	GS-BR-400W150	1	2.5			5.1	BR-N1-720W85			1	9.3				
7.5		GS4-47P5	54.3	14	GS-BR-1K0W075	1	3.7			10.2	BR-N1-1K2W50			1	15.8				
10		GS4-4010	47.5	16	GS-BR-1K5W043	1	5.1			17.6	BR-N1-1K5W40			1	19.8				
15		GS4-4015	42.2	18	GS-BR-1K0W016	2S	B			10.2	24			BR-N1-1K7W30	1	F	26.3		
20		GS4-4020	26.2	29	GS-BR-1K0W016	2S				12.2				BR-N1-2K3W26	1				30.4
25		GS4-4025	23.0	33	GS-BR-1K5W013	2S				14.9				29	BR-N1-2K8W25				1
30		GS4-4030	23.0	33	GS-BR-1K0W016	4 (2S/2P)	D			20.3	47.5			BR-N1-4K0W16P0	1	49.4			
40		GS4-4040	14.1	54	Not offered					BR-N1-4K7W14P7	1	53.7							
50		GS4-4050	12.7*	60*	Not offered					BR-N1-6K9W13P6	1	58.1							
60		GS4-4060	12.7*	60*	Not offered					BR-N1-3K6W20	2 (1/DBU)	39.5*							
75		GS4-4075	9.5*	80*	Not offered					BR-N1-4K7W14P7	2 (1/DBU)	53.7*							
100		GS4-4100	6.3*	120*	Not offered					BR-N1-6K9W13P6	2 (1/DBU)	58.1*							
125		GS4-4125	6.3*	120*	Not offered					BR-N1-13K0W06P4	1	123.4							
150		GS4-4150	6.0*	126*	Not offered					BR-N1-18K0W03P7	1	213.5							
175		GS4-4175	4.0*	190*	Not offered					BR-N1-18K0W03P7	1	210.8							
200		GS4-4200	4.0*	190*	Not offered					BR-N1-13K0W06P4	2 (1/DBU)	123.4*							
250		GS4-4250	3.4*	225*	Not offered														
300	GS4-4300	3.0*	252*	Not offered															

\* These values are per individual DBU, as seen between DBU terminals B1 and B2.

\*\* 10% Duty Cycle with maximum ON (braking) time of 10 seconds.

# GS/DURAPULSE Drives Accessories – Braking Unit Specifications for GS4 & GS30 DURAPULSE AC Drives

## Braking Units for DURApulse AC Drives

### Overview

Braking units are applied to absorb the motor regeneration energy when the three-phase induction motor stops by deceleration.

GS-xDBU braking units, used with GS series braking resistors, provide optimum braking performance.



Note: Braking units are available ONLY for DURApulse drives.



**WARNING: TO AVOID INJURY OR MECHANICAL DAMAGE, PLEASE REFER TO USER MANUAL GS-DB\_UMP BEFORE WIRING.**



Dynamic Braking Unit Specifications – for GS4 & GS30 DURAPULSE AC Drives							
Braking Unit Part Number	GS-1DBU	GS-2DBU	GS-3DBU	GS-4DBU	GS-5DBU	GS-6DBU	GS-7DBU
Price	\$269.00	\$269.00	\$364.00	\$364.00	\$1,517.00	\$1,578.00	\$1,732.00
Nominal Voltage (VAC)	230			460			
Max Motor Capacity (hp/[kW])	20 [15]	30 [22]	40 [30]	60 [45]	150 [110]	200 [160]	250 [185]
Output Rating	Max Discharge Current (A) @ 10% Duty Cycle*	40	60	40	60	126	225
	Continuous Discharge Current (A)	15	20	15	18	45	100
	Braking Startup Voltage (VDC)	330/345/360/ 380/400/415 ±3V		600/690/720/ 760/800/830 ±6V		618/642/667/690/ 725/750 ±6V	
	Maximum On-Time (s)	10					
Input DC Voltage (VDC)	200–400		400–800		400–750		
Min Equivalent Resistor for Each Braking Unit (Ω)	10	6.8	20	13.6	6	4	3.4
Protection	Power CHARGE Lamp/LED	Comes ON until DC bus voltage (+P – -N) drops below 50VDC			Comes ON when DC bus voltage (DC+ – DC-) rises above 300VDC. Goes OFF when DC bus voltage (DC+ – DC-) drops below 100VDC.		
	Braking ACT Lamp/LED	ON during braking					
	Fault ERR Lamp	ON if a fault has occurred				n/a	
	Overcurrent Level LED (A)	n/a			190	290	340
	Overheat LED	n/a			Comes ON > 176°F [80°C]; Goes OFF < 149°F [65°C]		
	Heat Sink Overheat Temperature	203°F [95°C]			n/a		
Alarm Output Relay Contact	5A @ 120VAC/28VDC (RA,RB,RC)				3A @ 250VAC/28VDC (RA,RC)		
Environment	Installation Location	indoor (no corrosive gases; no metallic dust)					
	Operating Temperature	14°F to 122 °F [-10 to +50 °C]					
	Storage Temperature	-4 to +140 °F [-20 to +60 °C]					
	Humidity	less than 90% RH, non-condensing					
	Vibration	9.8 m/s <sup>2</sup> [1G] under 20Hz ; 2m/s <sup>2</sup> [0.2G] at 20–50 Hz					
Mechanical Configuration	IP50 wall-mount enclosed				IP10 wall-mount enclosed		

\* 10% Duty Cycle with maximum ON (braking) time of 10 seconds

# GS/DURAPULSE Drives Accessories – Braking Unit Basic Wiring for GS4 & GS30 DURAPULSE AC Drives

## Basic Dynamic Braking Wiring Diagram for GS4 & GS30 DURAPULSE AC Drives



Note: Smaller-capacity DURApulse AC Drives can connect directly to braking resistors, and do not require Dynamic Braking Units for braking. Other applications require multiple Resistors and/or multiple Dynamic Braking Units. Refer to “Dynamic Braking Component Selection” to determine which braking components are required for your application(s), and to the DURApulse Drives Dynamic Braking User Manual for complete wiring diagrams.

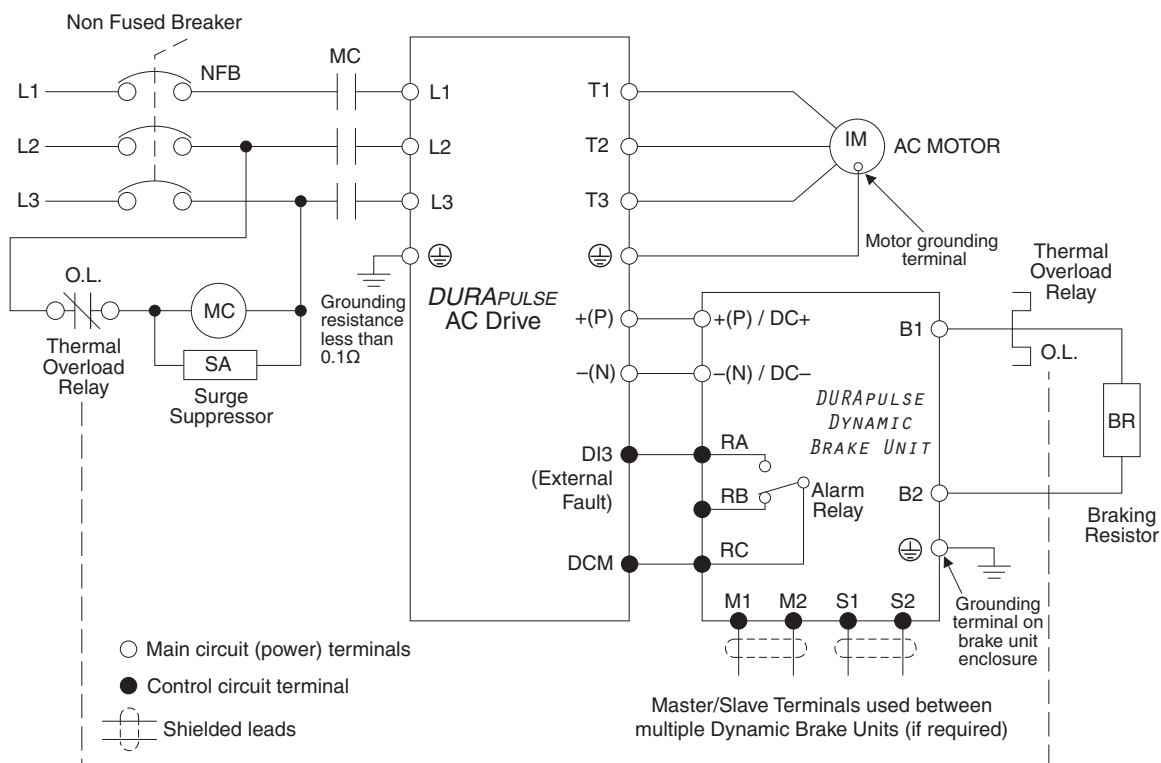

# GS/DURAPULSE Drives Accessories – Braking Unit Dimensions for GS4 & GS30 DURAPULSE AC Drives

## Braking Unit Dimensions ( Dimensions = mm [in] )

See our website: [www.AutomationDirect.com](http://www.AutomationDirect.com) for complete engineering drawings.

### A) DBU ≤ 100hp (GS-1DBU, GS-2DBU, GS-3DBU, GS-4DBU)

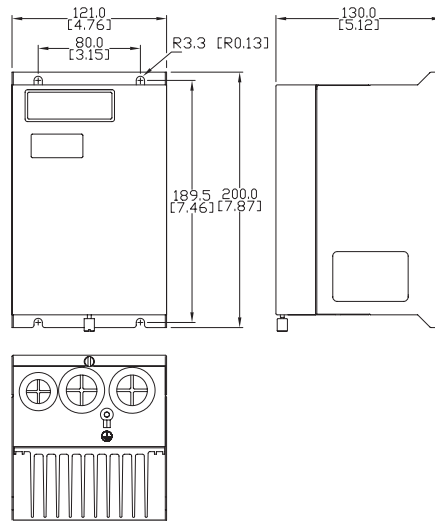

### B) DBU > 100hp (GS-5DBU, GS-6DBU, GS-7DBU)

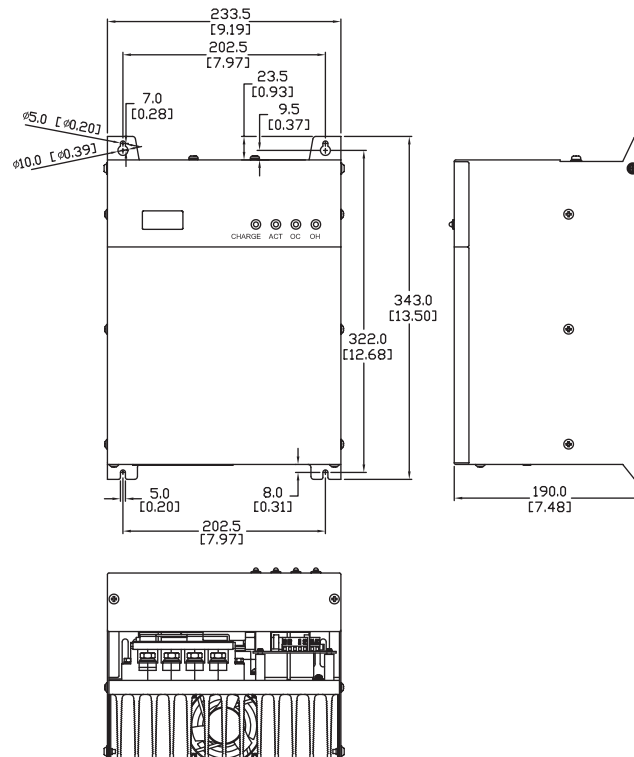

# AC Drives Optional Accessories – Overview

## Drive Accessories

(not all accessories are applicable for every drive model)

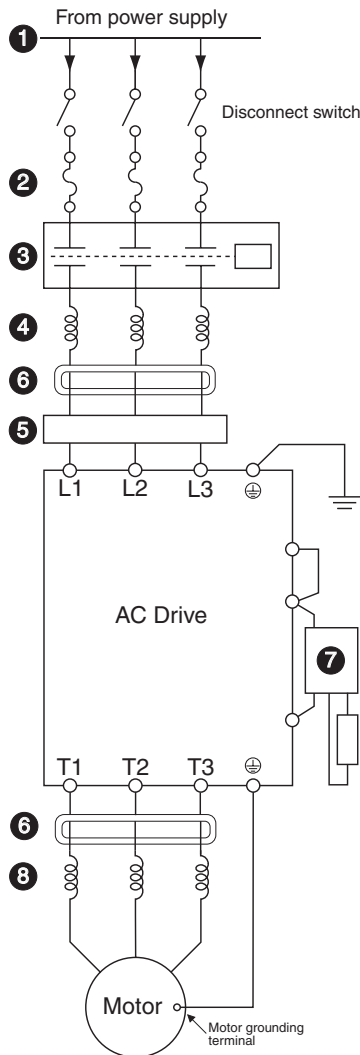

## 1 Power Supply

Please follow the specific power supply requirements as detailed in the specific drive manual.

## 2 Fuses

Input fuses protect the AC drive from excessive input current due to line surges, short circuits, and ground faults. They are recommended for all installations and may be required for UL-listed installations.

## 3 Contactor (Optional)

Do not use a contactor or disconnect switch for run/stop control of the AC drive and motor. This will reduce the operating life cycle of the AC drive. Cycling a power circuit switching device while the AC drive is in run mode should be done only in emergency situations.

## 4 Input Line Reactor (Optional)

See the Line Reactors section at [www.automationdirect.com](http://www.automationdirect.com) for more information.

Input line reactors protect the AC drive from transient overvoltage conditions, typically caused by utility capacitor switching. The input line reactor also reduces the harmonics associated with AC drives. Input line reactors are recommended for all installations.

## 5 EMI filter (Optional)

See the EMI Filters section at [www.automationdirect.com](http://www.automationdirect.com) for more information.

Input EMI filters reduce electromagnetic interference or noise on the input side of the AC drive. They are required for CE compliance and recommended for installations prone to or sensitive to electromagnetic interference.

## 6 RF filter (Optional)

RF filters reduce the radio frequency interference or noise on the input or output side of the inverter.

## 7 Braking Unit and/or Braking Resistor (Optional)

Dynamic braking allows the AC drive to produce additional braking (stopping) torque. AC drives can typically produce between 15% & 20% braking torque without the addition of any external components. The addition of optional braking may be required for applications that require rapid deceleration or high inertia loads.

## 8 Output Load Reactor or Voltage Time (dV/dT) Filter (Optional)

Output line reactors protect the motor insulation against AC drive short circuits and IGBT reflective wave damage, and also "smooth" the motor current waveform, allowing the motor to run cooler. They are **recommended for operating "noninverter-duty" motors and when the length of wiring between the AC drive and motor is less than 100 feet.**

**Voltage Time filters provide enhanced protection for motors with distances up to 1,000 feet.**

Voltage Time filters provide even more protection against wave reflection and reduce common mode noise. They are recommended when the length of wiring between the AC drive and motor is from 100 feet up to 1,000 feet.

See [www.automationdirect.com](http://www.automationdirect.com) for specific product offerings.