

# GS4 DURAPULSE Drives Accessories – Dynamic Braking Component Selection

## Dynamic Braking Components

Use the table below to find the appropriate braking resistor and braking unit (if applicable) for your GS4 series AC drive. For more information and installation instructions, please see the GS4 User Manual. All listed resistors are available for purchase at [www.automationdirect.com](http://www.automationdirect.com).

GS4 AC Drive Braking Component Selection																	
Drive Voltage	Motor Power (hp)	Drive Model	Drive Brake Capacity - Max Torque		Braking Unit		125% Braking Torque @ 10% Duty Cycle*										
			Min Resistor Value (Ω)	Max Total Brake Current (A)	Quantity	Part # GS-	Open Type Braking Resistor				NEMA1 Resistors with Thermal Switch						
							Part #	Quantity	Wiring Diagram	Brake Torque (kg-m)	Total Brake Current (A)	Part #	Qty.	Wiring Diagram	Total Brake Current (A)		
230V	1	GS4-21P0	63.3	6	-	n/a	GS-BR-080W200	1	A	0.5	1.9	BR-N1-240W150	1	A	2.6		
	2	GS4-22P0	47.5	8			GS-BR-200W091	1		1.0	4.2	BR-N1-280W50	1		7.8		
	3	GS4-23P0	38.0	10			GS-BR-300W070	1		1.5	5.4	BR-N1-800W25	1		15.6		
	5	GS4-25P0	19.0	20			GS-BR-400W040	1		2.5	9.5	BR-N1-800W18P0	1		21.7		
	7.5	GS4-27P5	14.6	26			GS-BR-1K0W020	1		3.7	19	BR-N1-1K1W15P0	1		26.0		
	10	GS4-2010	14.6	26			GS-BR-1K5W013	1		5.1	29	BR-N1-1K5W14P0	1		27.9		
	15	GS4-2015	12.6	28			GS-BR-1K0W4P3	2		B	10.2	44	BR-N1-2K2W08P6		1	F	45.3
	20	GS4-2020	8.3	46			GS-BR-1K0W4P3	2			12.2						
	25	GS4-2025	8.3	46			GS-BR-1K5W3P3	2			14.9	58	BR-N1-3K0W05P8		1		67.2
	40	GS4-2040	4.8*	80*			2	1DBU		Not offered					BR-N1-1K6W10P0		2 (1/DBU)
	50	GS4-2050	3.2*	120*			2	2DBU	BR-N1-2K2W06P8						2 (1/DBU)		116*
	60	GS4-2060	3.2*	120*			2	2DBU	BR-N1-3K6W06P8						2 (1/DBU)		
	75	GS4-2075	2.1*	180*			3	2DBU	BR-N1-2K2W06P8						3 (1/DBU)		
	100	GS4-2100	1.6*	240*			4	2DBU	BR-N1-2K2W06P8						4 (1/DBU)		
460V	1	GS4-41P0	190	4	-	n/a	GS-BR-080W750	1	A	0.5	1	BR-N1-240W200	1	A	4.0		
	2	GS4-42P0	126.7	6			GS-BR-200W360	1		1	2.1	BR-N1-240W150	1		5.3		
	3	GS4-43P0	108.6	7			GS-BR-300W250	1		1.5	3	BR-N1-500W200	1		4.0		
	5	GS4-45P0	84.4	9			GS-BR-400W150	1		2.5	5.1	BR-N1-500W130	1		6.1		
	7.5	GS4-47P5	54.3	14			GS-BR-1K0W075	1		3.7	10.2	BR-N1-720W85	1		9.3		
	10	GS4-4010	47.5	16			GS-BR-1K5W043	1		5.1	17.6	BR-N1-1K2W50	1		15.8		
	15	GS4-4015	42.2	18			GS-BR-1K0W016	2		B	10.2	24	BR-N1-1K5W40		1	19.8	
	20	GS4-4020	26.2	29			GS-BR-1K0W016	2			12.2						
	25	GS4-4025	23.0	33			GS-BR-1K5W013	2			14.9	29	BR-N1-1K7W30		1	26.3	
	30	GS4-4030	23.0	33			GS-BR-1K0W016	4		D	20.3	47.5	BR-N1-2K3W26		1	30.4	
	40	GS4-4040	14.1	54			Not offered				BR-N1-2K8W25	1	31.6				
	50	GS4-4050	12.7*	60*							1	4DBU	BR-N1-4K0W16P0		1	49.4	
	60	GS4-4060	12.7*	60*							1	4DBU	BR-N1-4K7W14P7		1	53.7	
	75	GS4-4075	9.5*	80*							2	3DBU	BR-N1-6K9W13P6		1	58.1	
	100	GS4-4100	6.3*	120*							2	4DBU	BR-N1-3K6W20		2 (1/DBU)	39.5*	
	125	GS4-4125	6.3*	120*			2	4DBU	BR-N1-4K7W14P7	2 (1/DBU)	53.7*						
	150	GS4-4150	6.0*	126*			1	5DBU	BR-N1-6K9W13P6	2 (1/DBU)	58.1*						
	175	GS4-4175	4.0*	190*			1	6DBU	BR-N1-13K0W06P4	1	123.4						
	200	GS4-4200	4.0*	190*			1	6DBU	BR-N1-18K0W03P7	1	213.5						
	250	GS4-4250	3.4*	225*			1	7DBU	BR-N1-13K0W06P4	1	210.8						
300	GS4-4300	3.0*	252*	2	5DBU	BR-N1-13K0W06P4	2 (1/DBU)	123.4*									

\* These values are per individual DBU, as seen between DBU terminals B1 and B2.

\*\* 10% Duty Cycle with maximum ON (braking) time of 10 seconds.

# GSxx DURAPULSE Drives Accessories – Dynamic Braking Component Selection

## Brake Wiring

Use your drive's Braking Component Selection table to determine the appropriate brake resistor model and configuration for your drive. Refer to the diagrams below for examples on how to wire each possible configuration

**Diagram A (Drive + 1 Resistor or NEMA1 Resistor):**

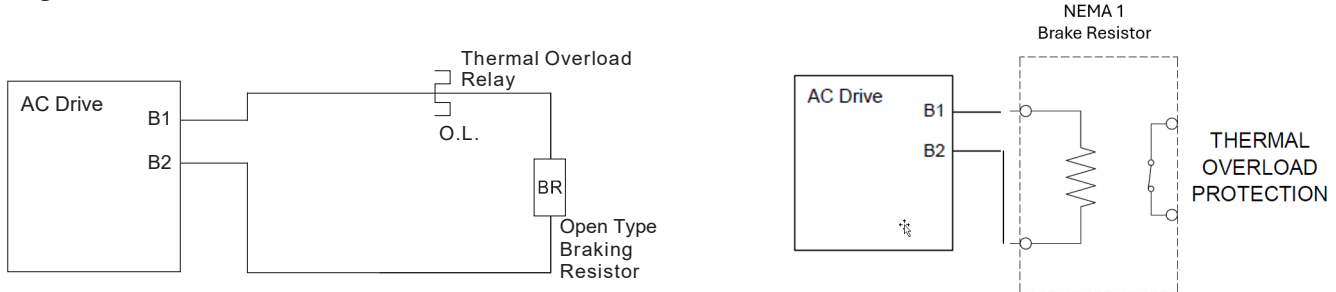

**Diagram B (Drive + 2 Series Resistors):**

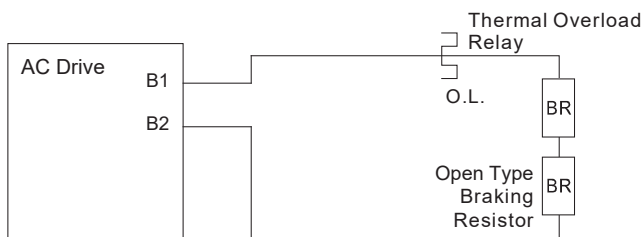

**Diagram C (Drive + 2 Parallel Resistors):**

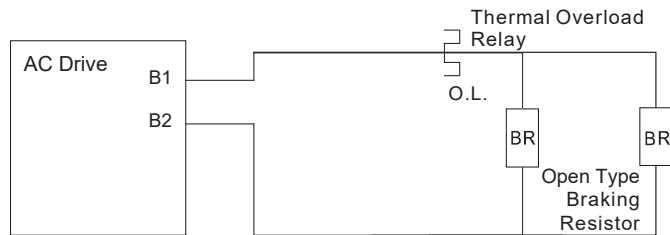

**Diagram D (drive + 2 Series and 2 Parallel Resistors):**

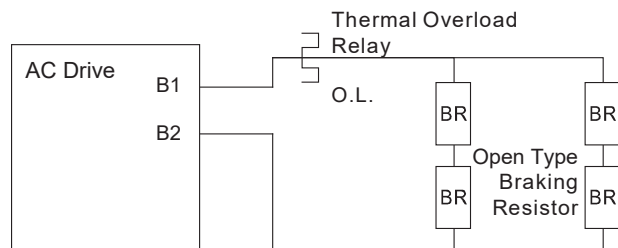

# GSxx DURAPULSE Drives Accessories – Dynamic Braking Component Selection

## Brake Wiring, *continued*

**Diagram E (Drive + 1 DBU with 1 NEMA1 Resistor):**

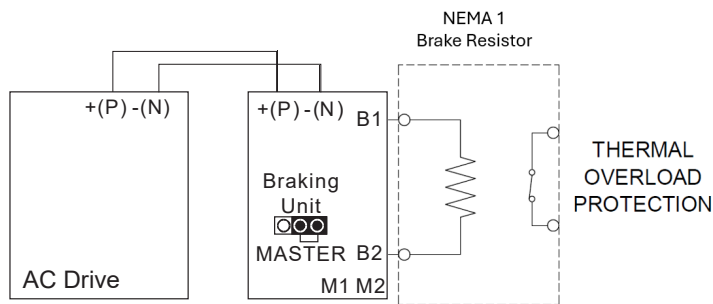

**Diagram F (Drive + DBUs with 1 Resistor or NEMA1 Resistor per DBU):**

