

PZ34 Series Linear Potentiometers With Cylindrical Case



Features

- PZ34 models feature a 0.75 in [19.05 mm] cylindrical housing
- Rod eye mounting system adds versatility for a wide range of applications
- Designed for easy installation thanks to an absence of electrical signal variation in output
- Ideal for applications such as wood and glass working, finishing machinery, and car test benches
- All potentiometers are individually tested at the manufacturer, and an individualized Linearity Error Chart is included with each unit

PZ34 Series Linear Potentiometers Selection Chart

Part Number	Price	Drawing Link	Useful Electrical Stroke (CEU) mm [in]	Theoretical Electrical Stroke (CET) mm [in]	Resistance (CET)	Mechanical Stroke (CM) mm [in]	Case Length (A) mm [in]	Minimum Distance Between Rod Eyes (C) mm [in]
PZ34-A-0025-L	\$198.00	PDF	25 [0.98]	26 [1.02]	1KΩ	30 [1.18]	110 [4.33]	163 [6.42]
PZ34-A-0050-L	\$207.00	PDF	50 [1.97]	51 [2.01]	2KΩ	55 [2.17]	135 [5.31]	188 [7.40]
PZ34-A-0075-L	\$210.00	PDF	75 [2.95]	76 [2.99]	3KΩ	80 [3.15]	160 [6.30]	213 [8.39]
PZ34-A-0100-L	\$215.00	PDF	100 [3.94]	101 [3.98]	4KΩ	105 [4.13]	185 [7.28]	238 [9.37]
PZ34-A-0125-L	\$218.00	PDF	125 [4.92]	126 [4.96]	5KΩ	130 [5.12]	210 [8.27]	263 [10.35]
PZ34-A-0150-L	\$221.00	PDF	150 [5.91]	151 [5.94]	6KΩ	155 [6.10]	235 [9.25]	288 [11.34]
PZ34-A-0200-L	\$225.00	PDF	200 [7.87]	201 [7.91]	7KΩ	205 [8.07]	285 [11.22]	338 [13.31]
PZ34-A-0250-L	\$235.00	PDF	250 [9.84]	251 [9.88]	8KΩ	255 [10.04]	335 [13.19]	388 [15.28]

PZ34 Series Linear Potentiometers Specifications

Model PZ34-A-xxxx-L	0025	0050	0075	0100	0125	0150	0200	0250
Independent Linearity (Within CEU)	± 0.2%	± 0.1%	± 0.1%	± 0.1%	± 0.05%	± 0.05%	± 0.05%	± 0.05%
Resolution	Infinite							
Repeatability	-							
Electrical Connections	PVC, 1m [3.28 ft] 3-wire axial cable, 24AWG (0.25 mm ²)							
Displacement Speed	≤ 10 m/s [32.81 ft/s]							
Protection Level	IP60							
Life	> 25x10 ⁶ strokes or > 100x10 ⁶ maneuvers, whichever is less (within CEU)							
Displacement Force	≤ 0.5 N							
Vibrations	5-2000 Hz: A _{max} =0.75 mm [0.03 in], a _{max} =20g							
Shock	50g, 11ms							
Acceleration	-							
Tolerance on Resistance	±20%							
Recommended Cursor Current	< 0.1 μA							
Maximum Cursor Current	10mA							
Maximum Applicable Voltage	20V	40V	60V	60V	60V	60V	60V	60V
Electrical Isolation	>100MΩ at 500V=, 1bar, 2s							
Dielectric Strength	< 100μA at 500V~, 50Hz, 2s, 1bar							
Dissipation at 40 °C [104 °F] (0W at 120 °C [248 °F])	0.8 W	1.6 W	2.6 W	3W	3W	3W	3W	3W
Thermal Coefficient of Resistance	-							
Actual Temperature Coefficient of Output Voltage	≤ 1.5 ppm/°C							
Working Temperature	-30 to +100°C [-22 to +212°F]							
Storage Temperature	-50 to +120°C [-58 to 248°F]							
Case Material	Anodized aluminum, Nylon 66							
Shaft Material	Stainless steel AISI 303							
Mounting	Self-aligning rod eyes							

PZ34 Series Linear Potentiometers With Cylindrical Case

Electrical Connections

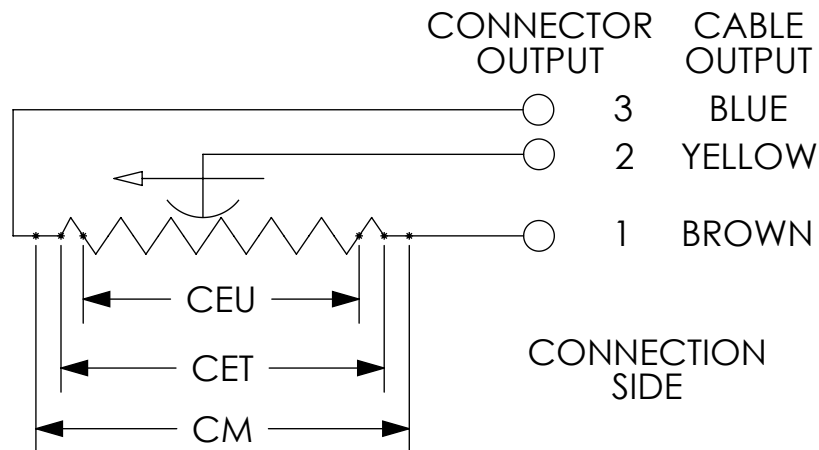

When choosing a transducer, it is important to remember that three different strokes exist:

- Mechanical Stroke (CM): The actual shift that the transducer's cursor (wiper) is able to make.
- Useful Electrical Stroke (CEU): The part of the mechanical stroke in which transducer linearity is guaranteed.
- Theoretical Electrical Stroke (CET): Stroke expressed in mm or angular degrees between the electrical zero ($V_{out}=0$) and the electrical limit switch ($V_{out}=V_s$), which physically is equal to the distance between the silver pitches at the ends of the resistive track.

Therefore, when designing an application, you should choose a transducer with a useful electrical stroke that is equal to or greater than the maximum displacement carried out by the moving part.