

PY2 Series Linear Potentiometers With Ball Tip

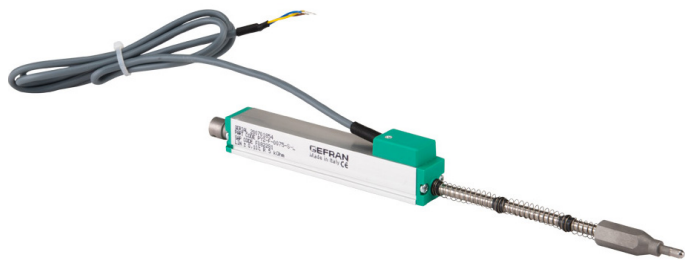

Features

- Excellent reliability under all conditions
- Mechanical linkage joint (M5 thread) takes up play
- Designed for easy installation thanks to an absence of electrical signal variation in output
- Mounting grooves provide a good alternative to fastening with brackets
- Typical applications include plastic injection presses, vertical presses, and many other types of processing machinery
- Grade of protection: IP40
- All potentiometers are individually tested at the manufacturer, and an individualized Linearity Error Chart is included with each unit

PY2 Series Linear Potentiometers Selection Chart

Part Number	Price	Drawing Link	Useful Electrical Stroke (CEU) mm [in]	Theoretical Electrical Stroke (CET) mm [in]	Resistance	Mechanical Stroke (CM) mm [in]	Case Length (A) mm [in]	Tip Length (B) mm [in]	Total Length (C) mm [in]	Mechanical Stop (Quote) (D) mm [in]
PY2-F-0010-S-L	\$168.00	PDF	10 [0.39]	11 [0.43]	1KΩ	15 [0.59]	48 [1.89]	32 [1.26]	108 [4.25]	–
PY2-F-0025-S-L	\$174.00	PDF	25 [0.98]	26 [1.02]	1KΩ	30 [1.18]	63 [2.48]	32 [1.26]	138 [5.43]	–
PY2-F-0050-S-L	\$180.00	PDF	50 [1.97]	51 [2.01]	5KΩ	55 [2.16]	88 [3.46]	40 [1.57]	196 [7.72]	–
PY2-F-0075-S-L	\$185.00	PDF	76 [2.99]	76 [2.99]	5KΩ	81 [3.19]	114 [4.49]	40 [1.57]	251 [9.88]	5 [0.20]
PY2-F-0100-S-L	\$189.00	PDF	101 [3.98]	101 [3.98]	5KΩ	106 [4.17]	139 [5.47]	40 [1.57]	307 [12.09]	11 [0.43]

PY2 Series Linear Potentiometers Specifications

Model PY2-F-xxxx-S-L	0010	0025	0050	0075	0100
Independent Linearity (Within CEU)	± 0.3%	± 0.2%	± 0.1%	± 0.1%	± 0.1%
Resolution	Infinite				
Repeatability	–				
Electrical Connections (LTM)	PVC, 1m [3.28 ft] 3-wire axial cable, 24AWG [0.25 mm ²]				
Displacement Speed	Standard ≤ 10 m/s [32.81 ft/s]				
Protection Level	IP40				
Life	> 25x10 ⁶ strokes or > 100x10 ⁶ maneuvers, whichever is less (within CEU)				
Displacement Force	≤ 4N				
Vibrations	5-2000 Hz: Amax=0.75 mm [0.03 in], amax=20g				
Shock	50g, 11ms				
Acceleration	–				
Tolerance on Resistance	±20%				
Recommended Cursor Current	< 0.1 μA				
Maximum Cursor Current	10mA				
Maximum Applicable Voltage	14V	25V	60V	60V	60V
Electrical Isolation	>100MΩ at 500V~, 1bar, 2s				
Dielectric Strength	< 100μA at 500V~, 50Hz, 2s, 1bar				
Dissipation at 40 °C [104 °F] (0W at 120 °C [248 °F])	0.2 W	0.6 W	1.2 W	1.8 W	2.4 W
Thermal Coefficient of Resistance	-200 to +200 ppm/°C				
Actual Temperature Coefficient of Output Voltage	≤ 1.5 ppm/°C				
Working Temperature	-30 to +100°C [-22 to +212°F]				
Storage Temperature	-50 to +120°C [-58 to 248°F]				
Case Material	Anodized aluminum, Nylon 66				
Shaft Material	Stainless steel AISI 303				
Mounting	Brackets with variable longitudinal axis				

PY2 Series Linear Potentiometers With Ball Tip

Electrical Connections

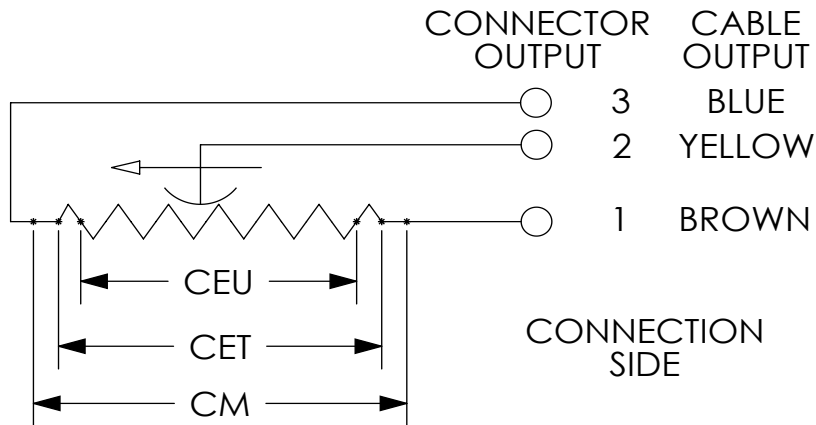

When choosing a transducer, it is important to remember that three different strokes exist:

- Mechanical Stroke (CM): The actual shift that the transducer's cursor (wiper) is able to make.
- Useful Electrical Stroke (CEU): The part of the mechanical stroke in which transducer linearity is guaranteed.
- Theoretical Electrical Stroke (CET): Stroke expressed in mm or angular degrees between the electrical zero ($V_{out}=0$) and the electrical limit switch ($V_{out}=V_s$), which physically is equal to the distance between the silver pitches at the ends of the resistive track.

Therefore, when designing an application, you should choose a transducer with a useful electrical stroke that is equal to or greater than the maximum displacement carried out by the moving part.