

Dold UF6925 Series

2-Channel Emergency Stop and Safety Gates



Designed to protect people and machines in applications with E-stop buttons and safety gates.

- 17.5 mm (0.69 in) slim housing
- Supply voltage 8-36 VDC
- Outputs: N.O. contacts (all models) plus 1 N.C. contact on UF6925-22-DC8-36
- Overvoltage and short-circuit protection
- Monitored restart
- LED indicators for power and state of operation

Safety Data – Values per EN ISO 13849-1	
Category	4
Performance level	e
MTTF_d	284.6 years
DC_{avg}	99%
Safety Data – Values per IEC/EN 62061 /IEC/EN 61508	
SIL CL	3
SIL	3
HFT (Hardware Failure Tolerance)	1
DC_{avg}	99%
PFH_D	8.30e-11

Safety Relays Selection Chart

Part Number	Price	Marking Type	Voltage	Outputs
UF6925-03-DC8-36	\$156.00	2-channel E-STOP / GATE	8-36 VDC	3 N.O.
UF6925-22-DC8-36	\$156.00			2 N.O. and 1 N.C.
UF6925-02-DC8-36	\$134.00			2 N.O.

UF6925 Controllers Safety Relay Specification Table

General Specifications	
Temperature	Storage: -25°C to 85°C (-13°F to 185°F)
Altitude	< 2,000m (6562ft)
Vibration Resistance	IEC/EN 60-068-2-6
Degree of Protection	Housing: IP40; Terminals IP20
Housing	UL 94V-0 Thermoplastic; DIN mount 35mm (1.38 in) x 7.5 mm (0.30 in)
Weight	140g (4.94 oz)
Agency Approvals and Standards	CSA, cULus file E107778, CE, RoHS, TUV
Terminal Designation per EN 50 005 Wire Connections	Min. 60°C copper conductors 28-14 AWG
Wire Fixing	Fixed spring clamp terminals
Input Specifications	
Nominal Voltage	8-36 VDC
Voltage Range	0.8-1.1 VDC
Maximum Consumption	< 1.6 W at 24VDC; < 2.2 W at 8-36 VDC
Nominal Frequency	-
Minimum Off-time	150ms
Control Voltage on S11 At UN	23VDC
Control Current Typ. Over S12, S22	30mA at UN
Min. Voltage on S12, S22 (relay activated)	19VDC
Short Circuit Protection	Internal with PTC (Positive Temperature Coefficient resistor)
Overvoltage Protection	Internal VDR (Voltage Dependent Resistor)
Output Specifications	
Electrical Contact Life	AC 15 at 8A, 230VAC; > 1.0x10 ⁵ switching cycles
Mechanical Life	> 40x10 ⁶ switching cycles
Contact Type	UF6925.02: 2 N.O. contacts – UF6925.03: 3 N.O. contacts UF6925.22: 2 N.O. contacts, 1 N.C. contact positively driven, N.O. contacts are safety contacts
Operating time at UN	< 350ms
Release Delay	< 90ms at 8-36 VDC – Disconnecting S12, S22: DC units: < 25ms
Nominal Output Voltage	AC: 230V; DC: See continuous current limit curve in installation manual.
Thermal Current (I_{th})	Max. 8A. See continuous current limit curve in installation manual.
Short Circuit Strength	Max. fuse rating: 8A gL (IEC/EN 60 947-5-1); Line circuit breaker: B 6A
Switching Capacity (IEC/EN 60 947-5-1)	AC15 N.O. contact: 3A / 230VAC; N.C. contact 1A / 230VAC DC13 N.O. contact: 2A / 24VDC; N.C. contact: 2A / 24VDC DC13 N.O. contact: 4A / 24VDC at 0.1 Hz; N.C. contact: 4A / 24VDC at 0.1 Hz
Switching Frequency	Max. 1200 switching cycles/hr

Dold UF6925 Series 2-Channel Emergency Stop and Safety Gates



Block Diagrams

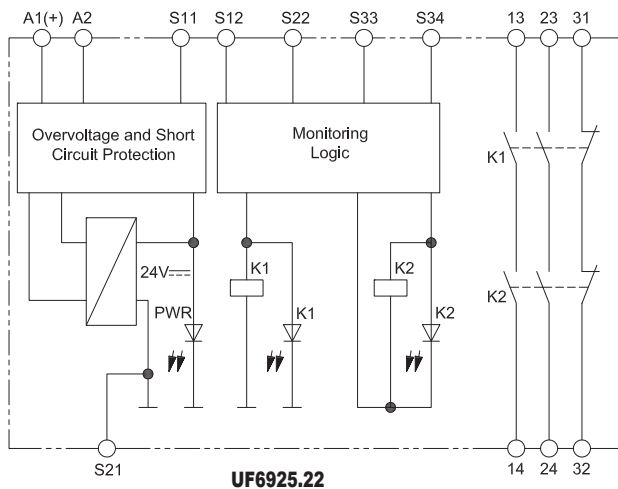
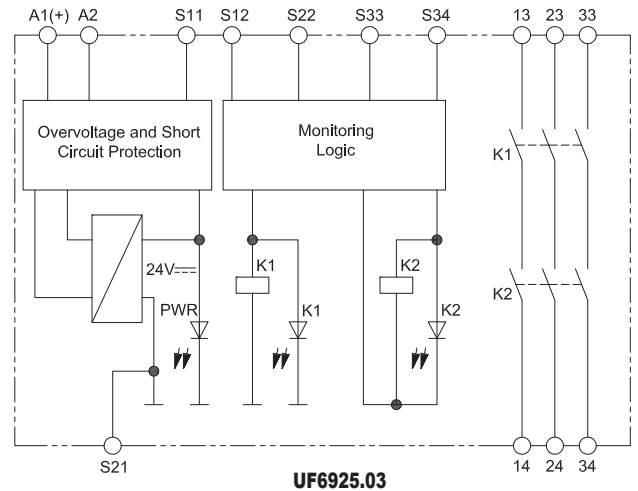
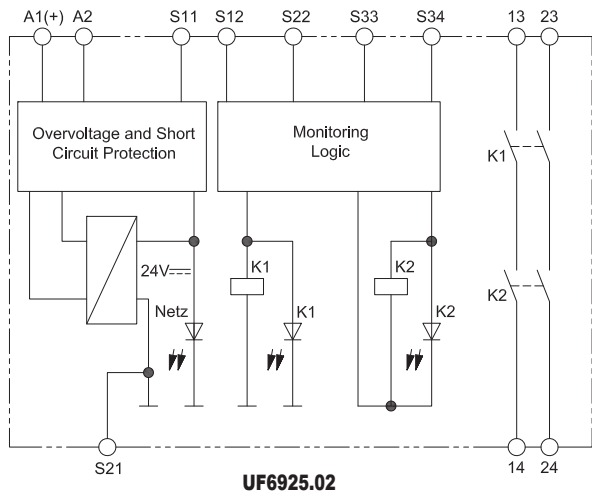

Dimensions

mm [in]

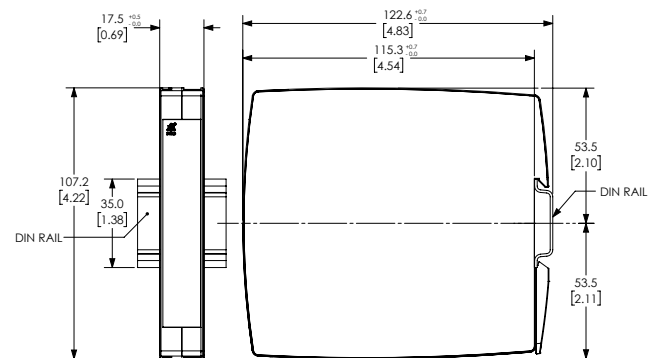

S1 and S2 Switch Setting Instructions

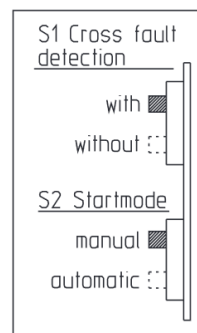
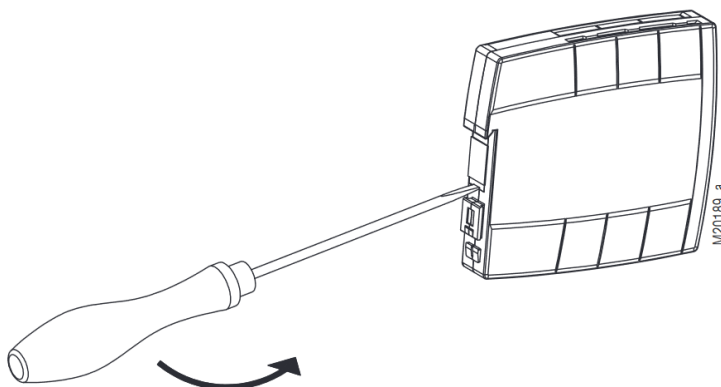

The selection of the functions auto start, manual start, with or without cross fault monitoring, is done with switches S1 and S2. These switches are located behind a cover at the back of the device. The setting of S1 and S2 must be made before starting the device.

Disconnect unit before setting S1 and S2.

Drawing shows setting as delivered to the customer.

M11589_a

Dold UF6925 Series 2-Channel Emergency Stop and Safety Gates



Application Examples

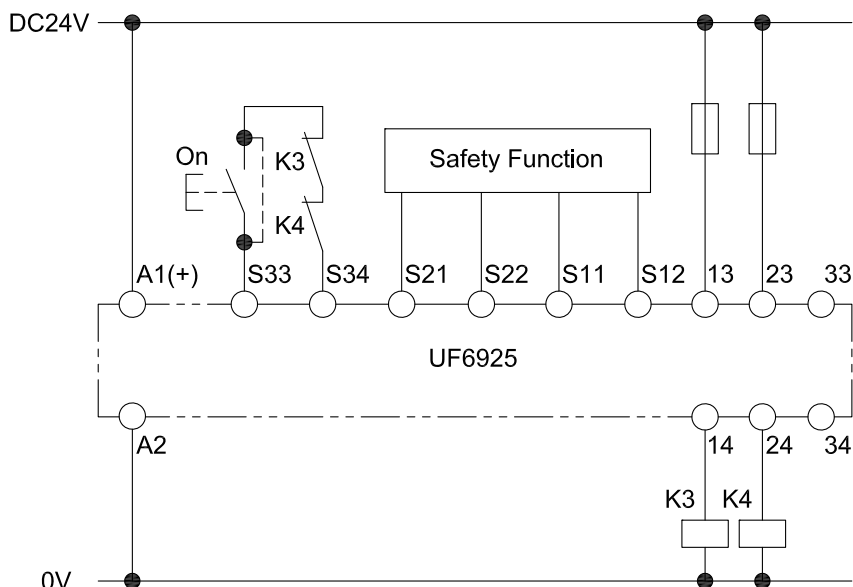

A jumper must be fitted at S33-S34 for the automatic ON function. The ON pushbutton is not required. The required start function has to be selected on switch S1 before starting the device. See "Unit Programming."

Safety function for units with cross fault detection (pay attention to "Unit Programming"!)



Safety function for units without cross fault detection (pay attention to "Unit Programming"!)

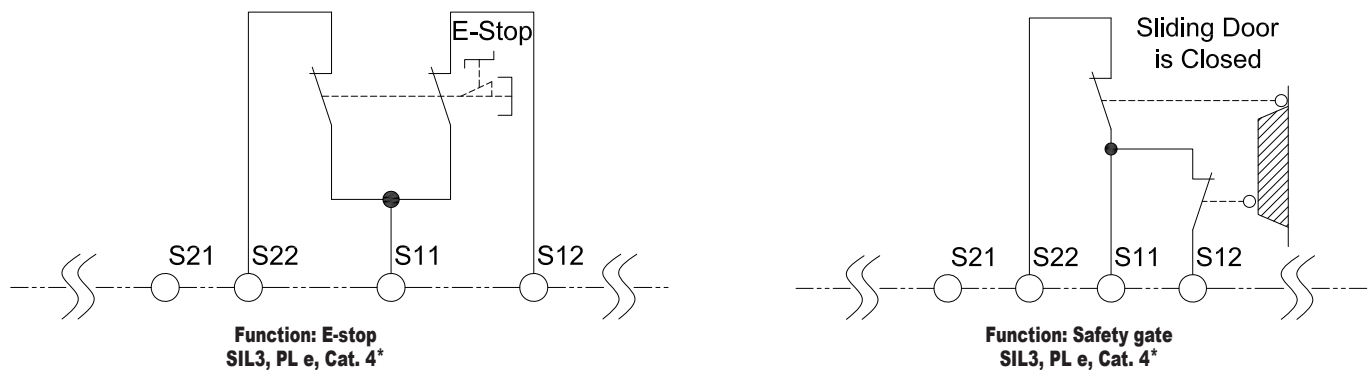

* To achieve the safety classification, cross fault wiring must be installed.

Safety Products



Warning: Safety products sold by AutomationDirect are Safety components only. The purchaser/installer is solely responsible for the application of these components and ensuring all necessary steps have been taken to assure each application and use meets all performance and applicable safety requirements and/or local, national and/or international safety codes as required by the application. AutomationDirect cannot certify that our products, used solely or in conjunction with other AutomationDirect or other vendors' products, will assure safety for any application. Any person using or applying any products sold by AutomationDirect is responsible for learning the safety requirements for their individual application and applying them, and therefore assumes all risks, and accepts full and complete responsibility, for the selection and suitability of the product for their respective application.

AutomationDirect does not provide design or consulting services, and cannot advise whether any specific application or use of our products would ensure compliance with the safety requirements for any application.