

DL405 Programming Tools and Cables

Select a programming device

There are two tools for programming the DL405 CPUs: DirectSOFT PC-based programming software and the D4-HPP-1 handheld programmer.

DirectSOFT programming software

Our powerful Windows-based programming packages make it easy for you to program and monitor your DL405 PLC system. The version of the software that supports the DL405 CPUs is described in the table below. See the DirectLOGIC Overview Section DL in this catalog for detailed information on DirectSOFT.

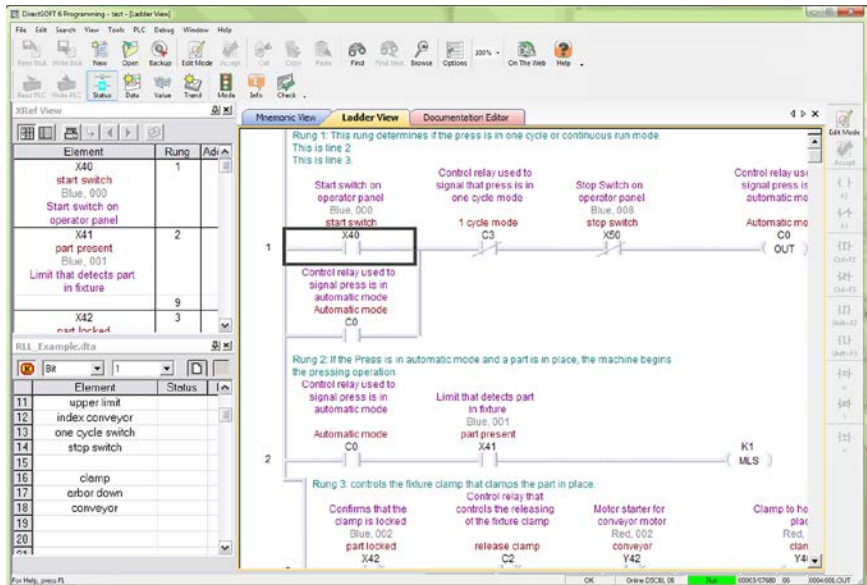

Direct Soft Part Number	Price	Description
D4-HPP-1	Retired	Handheld Programmer
PC-D5OFT6	\$462.00	Programs all PLC families DL05/06/105/205/305/405
PC-DS100	Free	Free version of DirectSOFT; programs all DirectLOGIC PLC CPUs; limited to 100 word program

DL405 programming cables

Choose the proper cable to connect the DL405 CPU to your PC running DirectSOFT.

CPU	Price	Port	Cable	Price
D4-454	\$1,071.00	Top port (15 pin)	D4-DSCBL	\$74.00
		Lower port (25pin)	D3-DSCBL-2	\$66.00
		Phone jack (RJ12)	D2-DSCBL	\$35.00

Pin labeling conforms to IBM DTE and DCE standards

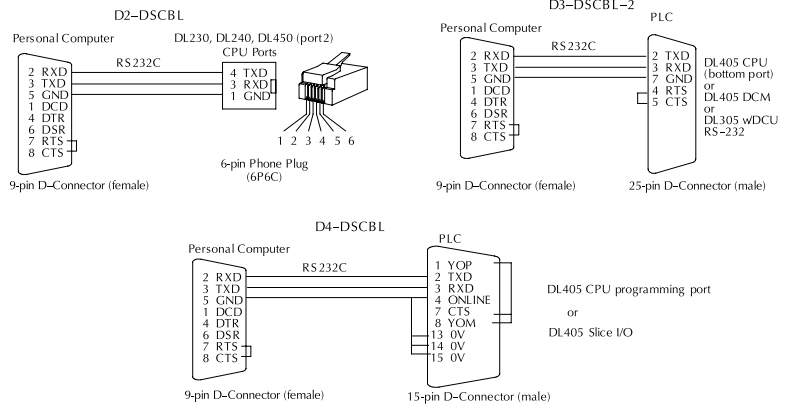

Handheld programmer

The D4-HPP-1 handheld programmer connects to the 15-pin port on any of the DL405 CPUs. A memory cartridge is located on the side of the handheld programmer. This slot allows you to copy memory cartridges (including UV PROMs) and transfer data/programs between the CPU and a memory cartridge.

