

Counter Interface Module

COUNTER INTERFACE MODULE

D2-CTRINT \$150.00



Note: D2-262 does not support the D2-CTRINT

Overview

The D2-CTRINT offers several modes of operation that can be used to solve simple motion and high-speed machine control applications.

The operating modes and module configuration are explained in detail in the D2-CTRIF-M High Speed Counter Manual. The high-speed input features cannot be used if the pulse output features are in use, and vice versa. Only one D2-CTRINT can be used per CPU and the module must reside in slot 0, next to the CPU. A brief description of each high-speed mode is listed below:

Mode 10: Up to two 5kHz high-speed counters offer 24 presets each. When the preset is reached, a CPU interrupt routine is executed.

Mode 20: Quadrature encoder input (up/down) for clockwise and counterclockwise position control (max. pulse range: -8,388,608 to 8,388,607).

Mode 30: Pulse outputs are programmable to follow a predetermined profile. An external interrupt can be used in conjunction with separate acceleration and deceleration profiles for positioning and velocity control supported by D2-250-1 (max. pulse range: -8,388,608 to 8,388,607 at 5K pulses per second max).

Mode 40: Four external interrupt inputs can be used for an immediate response for high-priority events.

Mode 50: Pulse catch feature allows the CPU to read 4 inputs, each having a pulse width as small as 0.1 ms. When an input pulse is detected, the input is set ON for the next scan and then resets.

Counter Interface Module Features					
Mode	Module Points				
	Input 0	Input 1	Input 2	Input 3	Input 4
Mode 10: Two High Speed Up Counters	Up counter 1	Up counter 2 Filtered input	Reset counter 1	Reset counter 2	Not used
Mode 20: One Up/Down or Quadrature cntr	Phase A input (up count)	Phase B input (down count)	Counter reset	Filtered input	Not used
Mode 30: Pulse Output	Filtered input	Filtered input	Not used	CW pulse output (or Pulse output)	CCW pulse out (or Direction)
Mode 40: External Interrupts	Interrupt input (not available when using timed interrupt)	Interrupt input	Interrupt input	Interrupt input	Not used
Mode 50: Pulse Catch Inputs	Pulse input	Pulse input	Pulse input	Pulse input	Not used
Mode 60: Filtered Input	Filtered input	Filtered input	Filtered input	Filtered input	Not used

The high-speed input features cannot be used if the pulse output features are in use, and vice versa.

Input Specifications

Input	4 pts. sink/source 5 kHz max.
Minimum pulse width	100µs
Input Voltage Range	12 or 24 VDC ±15%
Maximum voltage	30VDC
Rated input current	10mA Typical 13mA Maximum
Minimum ON voltage	8.0 VDC
Maximum OFF voltage	1.0 VDC
Minimum ON Current	8.0 mA
Maximum OFF Current	1.0 mA
OFF to ON Response	Less than 30µs
ON to OFF Response	Less than 30µs

Mode 60: Input filters are configurable (0-99ms) to ensure input signal integrity. The default input mode is a 10ms filter.

Mode 40 option - A Timed interrupt can be configured for time critical events. Interrupt 0 can be scheduled on a 3ms-999ms cycle. See the next page for more information on the timed interrupt.

Output Specifications

Output	2 pts., current sinking 5kHz Max
Voltage range	5.0 VDC±15%
Maximum voltage	5.5 VDC
Maximum load current	30mA
Minimum load voltage	4.5 VDC
Leakage current	Less than 0.1 mA at 5.5 VDC
Inrush current	0.5 A (10ms)
OFF to ON Response	Less than 30µs
On to OFF Response	Less than 30µs
External power supply	5.0 VDC ±10%

General Specifications

Module Type	Discrete
Modules per CPU	One only in slot adjacent to CPU
I/O Points Used	8 inputs, 8 outputs
Field Wiring Connector	Standard 8 pt. removable terminal block
Internal Power Consumption	50mA from 5VDC max., (supplied by the CPU base power supply)
Operating Environment	32°F to 140°F (0°C to 60°C) humidity (non-condensing) 5% to 95%
Manufacturer	Koyo Electronics

Counter Interface Module

Wiring Diagram for Modes 10, 20, 40, 50 and 60

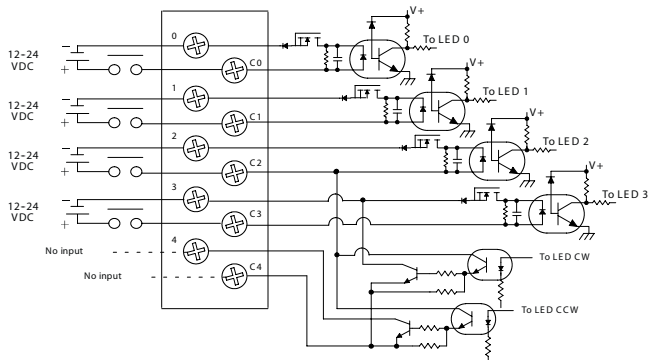

Wiring Diagram for Mode 30

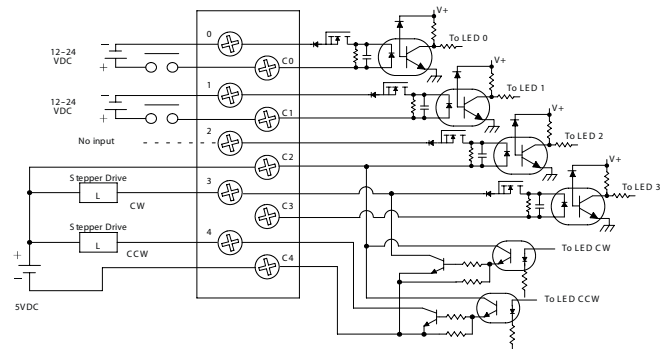

Timed Interrupt feature

There is an internal timed interrupt feature available in the D2-262 CPU. You do not need the Counter Interface module to use the timed interrupt. This cyclical interrupt allows you to easily program a time-based interrupt that occurs on a scheduled basis. The CPU's timed interrupt operates in a similar manner to the external interrupt input, but instead of the interrupt subroutine being triggered by an external event, it is now triggered by a cyclical interval of time. This interval can be programmed from 3ms to 999ms. Whenever the programmed time elapses, the CPU immediately suspends its routine scan cycle and jumps to interrupt subroutine INT0. As with the other modes, when the subroutine execution is complete, the CPU automatically resumes its routine scan cycle starting at the exact location where it was interrupted. Since the CPU scan time and the interrupt time interval are different, the program gets interrupted at various points in the execution over time. The CPU returns to the point where it left to resume the program execution.

If you use a timed interrupt and the Counter Interface module, Input 0 cannot be used on the Counter Interface module. If you're using the timed interrupt and a standard discrete input module, then there are no limitations.

Timed Interrupt Specifications	
Timed interrupts	One (internal to CPU)
Time interval	3ms to 999ms (1ms increments)
Interrupt Subroutine	INT0

Timed interrupt operation

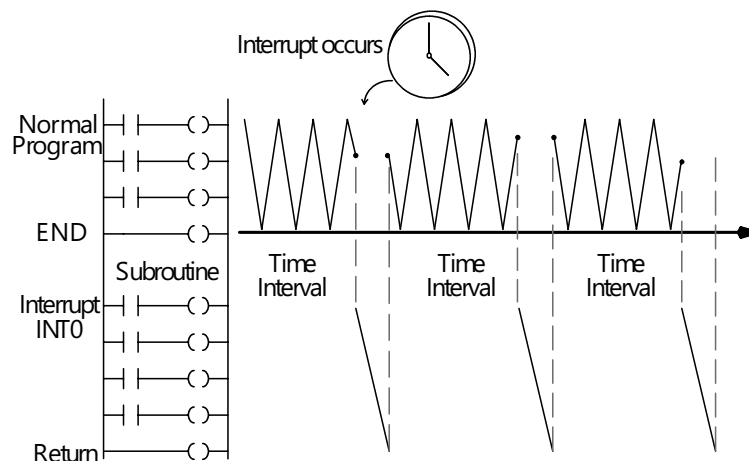



Dimensions and Installation

Understanding the installation requirements for your DL205 system will help ensure that the DL205 products operate within their environmental and electrical limits.

Plan for safety

This catalog should never be used as a replacement for the user manual. The user manual, D2-USER-M (downloadable online), contains important safety information that must be followed. The system installation should comply with all appropriate electrical codes and standards.

Environmental specifications

The Environmental Specifications table at the right lists specifications that apply globally to the DL205 system (CPUs, bases, and I/O modules). Be sure that the DL205 system is operated within these environmental specifications.

Base dimensions and mounting

Use the diagrams below to make sure the DL205 system can be installed in your application. To ensure proper airflow for cooling purposes, DL205 bases must be mounted horizontally. It is important to check these dimensions against the conditions required for your application. For example, it is recommended that approximately 3" of space is left in front PLC surface for ease of access and cable clearances. Also, check the installation guidelines for recommended cabinet clearances.

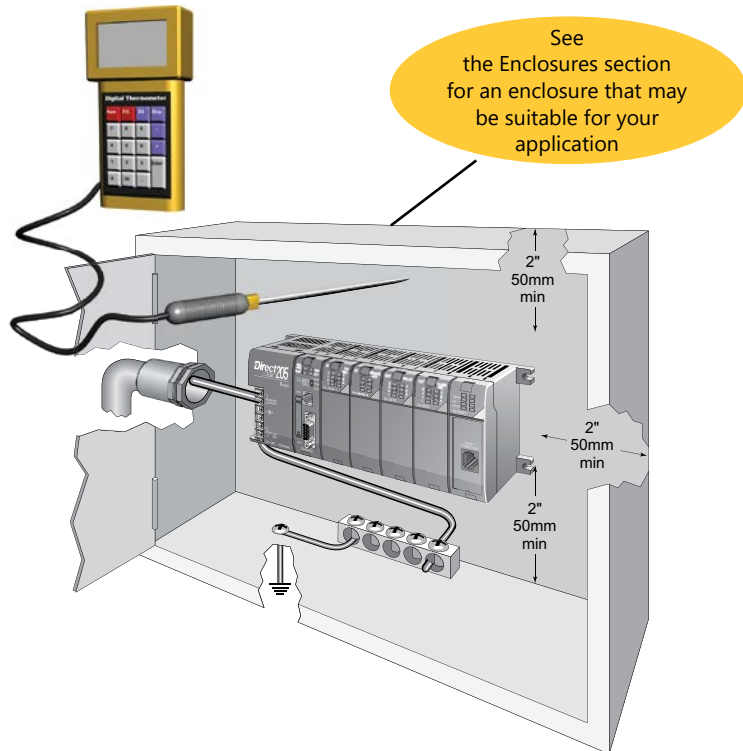

Environmental Specification	Rating
Storage Temperature	-4°F to 158°F (-20°C to 70°C)
Ambient Operating Temperature	32°F to 131°F (0°C to 55°C)
Ambient Humidity	30% to 95% relative humidity (non-condensing)
Vibration Resistance	MIL STD 810C, Method 514.2
Shock Resistance	MIL STD 810C, Method 516.2
Noise Immunity	NEMA (ICS3-304)
Atmosphere	No corrosive gases

Base	A	B	C	D
D2-03B-1, D2-03BDC1-1	6.77" 172mm	6.41" 163mm	5.8" 148mm	7.24" 184mm
D2-04B-1, D2-04BDC1-1	7.99" 203mm	7.63" 194mm	7.04" 179mm	8.46" 215mm
D2-06B-1, D2-06BDC1-1, D2-06BDC2-1	10.43" 265mm	10.07" 256mm	9.48" 241mm	10.90" 277mm
D2-09B-1, D2-09BDC1-1, D2-09BDC2-1	14.09" 358mm	13.74" 349mm	13.14" 334mm	14.56" 370mm

