



PLC I/O Modules to ZIPLink Connector Modules - DL05/06

DL05/06 PLC Input Module ZIPLink Selector				
PLC		ZIPLink		
Input Module	# of Terms	Component	Module Part No.	Cable Part No.
D0-10ND3	13	Feedthrough	ZL-RTB20	ZL-D0-CBL13
D0-10ND3F	13	Feedthrough		
D0-16ND3	24	Feedthrough	ZL-LTB16-24-1	ZL-D0-CBL24-L
		Sensor		ZL-D0-CBL24-1L
F0-08NA-1	10	See Note 2		

DL05/06 PLC Output Module ZIPLink Selector				
PLC		ZIPLink		
Output Module	# of Terms	Component	Module Part No.	Cable Part No.
D0-10TD1	13	Feedthrough	ZL-RTB20	ZL-D0-CBL13
		Feedthrough	ZL-RTB20	ZL-D0-CBL24 *
D0-16TD1	24	Fuse	ZL-RFU20 ³	ZL-D0-CBL24 *
		Relay (sinking)	ZL-RRL16-24-1	ZL-D0-CBL24 *
		Relay (sourcing)	ZL-RRL16-24-2	ZL-D0-CBL24 *
D0-10TD2	13	Feedthrough	ZL-RTB20	ZL-D0-CBL13
D0-16TD2	24	Feedthrough	ZL-RTB20	ZL-D0-CBL24 *
		Fuse	ZL-RFU20 ³	ZL-D0-CBL24 *
		Relay (sourcing)	ZL-RRL16-24-2	ZL-D0-CBL24 *
D0-08TR	10	See Note 2		
F0-04TRS¹	13	Feedthrough	ZL-RTB20	ZL-D0-CBL13

DL05/06 PLC Combo In/Out Module ZIPLink Selector				
PLC		ZIPLink		
Combo Module	# of Terms	Component	Module Part No.	Cable Part No.
D0-07CDR	10	See Note 2		
D0-08CDD1	13	Feedthrough	ZL-RTB20	ZL-D0-CBL13

DL05/06 PLC Fixed I/O ZIPLink Selector				
PLC		ZIPLink		
PLC	# of Terms	Component	Module Part No.	Cable Part No.
DL05	18	See Note 2		
DL06	20 (Input side only)	Feedthrough	ZL-RTB20	ZL-D06X-CBL20
	20 (Output side only)	Feedthrough	ZL-RTB20	ZL-D06Y-CBL20

DL05/06 PLC Analog Module ZIPLink Selector				
PLC		ZIPLink		
Analog Module	# of Terms	Component	Module	Cable
F0-04AD-1	8	See Note 2		
F0-04AD-2	8			
F0-08ADH-1	13	Feedthrough	ZL-RTB20	ZL-D0-CBL13
F0-08ADH-2	13			
F0-04DAH-1	13			
F0-08DAH-1	13			
F0-04DAH-2	13			
F0-08DAH-2	13			
F0-2AD2DA-2	8			
F0-4AD2DA-1	8			
F0-4AD2DA-2	8			
F0-04RTD	Matched Only			
F0-04THM	Matched Only			

* Select the cable length by replacing the * with: Blank = 0.5 m, -1 = 1.0 m, or -2 = 2.0 m.
¹ Caution: The F0-04TRS relay outputs are derated not to exceed 2A per point when used with the ZIPLink wiring system.
² These modules are not supported by the ZIPLink wiring system.
³ Note: Fuses (5 x 20 mm) are not included. See Edison Electronic Fuse section for (5 x 20 mm) fuse. S500 and GMA electronic circuit protection for fast-acting maximum protection. S506 and GMC electronic circuit protection for time-delay performance. Ideal for inductive circuits.
 To ensure proper operation, do not exceed the voltage and current rating of ZIPLink module. ZL-RFU20 = 2A per circuit; ZL-RFU40 = 400mA per circuit.



Note: ZIPLink Connector Modules and ZIPLink Cables specifications are in the ZIPLink catalog section.





Wiring Solutions

Wiring Solutions using the ZIPLink Wiring System

ZIPLinks eliminate the normally tedious process of wiring between devices by utilizing prewired cables and DIN rail mount connector modules. It's as simple as plugging in a cable connector at either end or terminating wires at only one end. Prewired cables keep installation clean and efficient, using half the space at a fraction of the cost of standard terminal blocks. There are several wiring solutions available when using the **ZIPLink** System ranging from

PLC I/O-to-**ZIPLink** Connector Modules that are ready for field termination, options for connecting to third party devices, GS, DuraPulse and SureServo Drives, and specialty relay, transorb and communications modules. Pre-printed I/O-specific adhesive label strips for quick marking of **ZIPLink** modules are provided with **ZIPLink** cables. See the following solutions to help determine the best **ZIPLink** system for your application.

Solution 1: DirectLOGIC I/O Modules to ZIPLink Connector Modules

When looking for quick and easy I/O-to-field termination, a **ZIPLink** connector module used in conjunction with a prewired **ZIPLink** cable, consisting of an I/O terminal block at one end and a multi-pin connector at the other end, is the best solution.

Using the PLC I/O Modules to **ZIPLink** Connector Modules selector tables located in this section,

1. Locate your I/O module/PLC.
2. Select a **ZIPLink** module.
3. Select a corresponding **ZIPLink** cable.



Solution 2: DirectLOGIC I/O Modules to 3rd Party Devices

For connecting I/O to another device within close proximity of the I/O modules, no extra terminal blocks are necessary when using the **ZIPLink** Pigtail Cables. **ZIPLink** Pigtail Cables are prewired to an I/O terminal block with color-coded pigtail with soldered-tip wires on the other end.

Using the I/O Modules to 3rd Party Devices selector tables located in this section,

1. Locate your PLC I/O module.
2. Select a **ZIPLink** pigtail cable that is compatible with your 3rd party device.



Solution 3: GS Series and DuraPulse Drives Communication Cables

Need to communicate via Modbus RTU to a drive or a network of drives?

ZIPLink cables are available in a wide range of configurations for connecting to PLCs and SureServo, SureStep, Stellar soft starters and AC drives. Add a **ZIPLink** communications module to quickly and easily set up a multi-device network.

Using the Drives Communication selector tables located in this section,

1. Locate your drive and type of communications.
2. Select a **ZIPLink** cable and other associated hardware.





Wiring Solutions

Solution 4: Serial Communications Cables

ZIPLink offers communications cables for use with DirectLOGIC, CLICK, and Productivity3000 CPUs, that can also be used with other communications devices. Connections include a 6-pin RJ12 or 9-pin, 15-pin and 25-pin D-sub connectors which can be used in conjunction with the RJ12 or D-Sub Feedthrough modules.

Using the Serial Communications Cables selector table located in this section,

1. Locate your connector type.
2. Select a cable.



Solution 5: Specialty ZIPLink Modules

For additional application solutions, **ZIPLink** modules are available in a variety of configurations including stand-alone relays, 24VDC and 120VAC transorb modules, D-sub and RJ12 feedthrough modules, communication port adapter and distribution modules, and SureServo 50-pin I/O interface connection.

Using the **ZIPLink** Specialty Modules selector table located in this section,

1. Locate the type of application.
2. Select a **ZIPLink** module.



Solution 6: ZIPLink Connector Modules to 3rd Party Devices

If you need a way to connect your device to terminal blocks without all that wiring time, then our pigtail cables with color-coded soldered-tip wires are a good solution. Used in conjunction with any compatible **ZIPLink** connector modules, a pigtail cable keeps wiring clean and easy and reduces troubleshooting time.

Using the Universal Connector Modules and Pigtail Cables table located in this section,

1. Select module type.
2. Select the number of pins.
3. Select cable.



DL05/06 Option Modules

F0-04AD-1 **\$139.00**

4-channel analog current input module

F0-04AD-1 Input Specifications	
Number of Channels	4, single ended (one common)
Input Range	0 to 20 mA or 4 to 20 mA (jumper selectable)
Resolution	12 bit (1 in 4096)
Step Response	25.0 ms (typ.) to 95% of full step change
Crosstalk	1/2 count max (-80db)*
Active Low-pass Filtering	-3dB at 40Hz (-12dB per octave)
Input Impedance	125Ω ±0.1%, 1/8 watt
Absolute Max Ratings	-30mA to +30mA, current input
Converter Type	Successive approximation
Linearity Error (end to end)	±2 counts
Input Stability	±1 count*
Full-scale Calibration Error	±10 counts max. @ 20mA*
Offset Calibration Error	±5 counts max. @ 4mA*
Max Inaccuracy	±0.4% at 25-C (77°F) ±0.85% at 0 to 60°C (32 to 140°F)
Accuracy vs. Temperature	±100 ppm/-C typical
Terminal Type (Included)	Removable: F0-IOCON
Recommended Fuse	0.032 A, series 217 fast-acting, current inputs

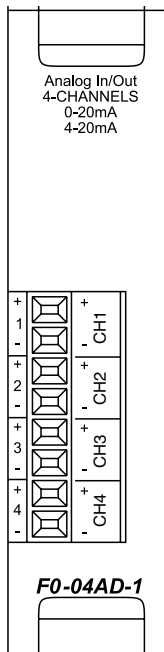

See [Wiring Solutions](#) for part numbers of ZIPLINK cables and connection modules compatible with this I/O module.

* One count in the specification table is equal to one least significant bit of the analog data value (1 in 4096)

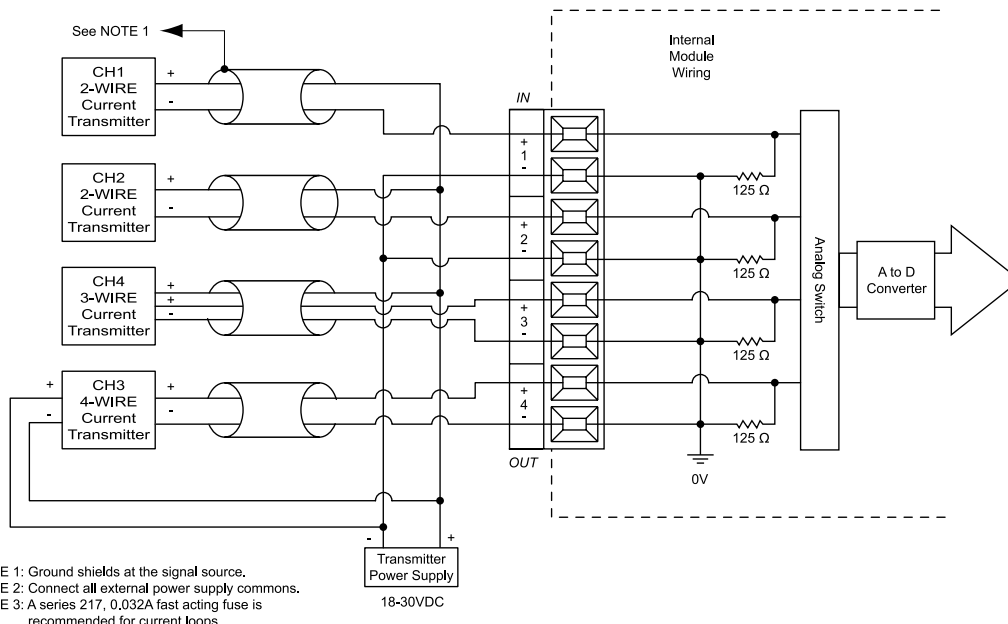

DL05/06 I/O Option Modules

F0-04AD-2 **\$204.00**

4-channel analog voltage input module

F0-04AD-2 Input Specifications	
Number of Channels	4, single ended (one common)
Input Range	0 to 5 VDC or 0 to 10 VDC (jumper selectable)
Resolution	12 bit (1 in 4096)
Step Response	10.0 ms to 95% of full step change
Crosstalk	1/2 count max (-80db)*
Active Low-pass Filtering	-3dB at 300Hz (-12dB per octave)
Input Impedance	L20kΩ
Absolute Max Ratings	±15V
Linearity Error (end to end)	±2 count (0.025% of full scale) max*
Input Stability	w1 count*
Gain Error	±6 counts max*
Offset Error	±2 counts max*
Terminal Type (Included)	Removable: F0-IOCON
Max Inaccuracy	±0.3% at 25-C (77-F)
	±0.6% at 0 to 60°C (32 to 140°F)
Accuracy vs. Temperature	±100 ppm/°C typical

CPU	Firmware Required	DirectSOFT32 Required
DL05	Version 4.60 or later	Version 3.0c or later
DL06	Version 1.40 or later	Version 4.0, Build 16 or later



See Wiring Solutions for part numbers of ZIPLink cables and connection modules compatible with this I/O module.

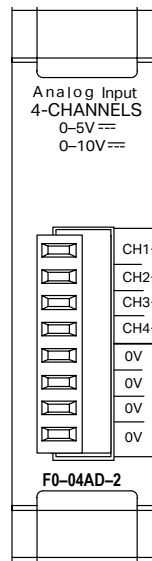

* One count in the specification table is equal to one least significant bit of the analog data value (1 in 4096)

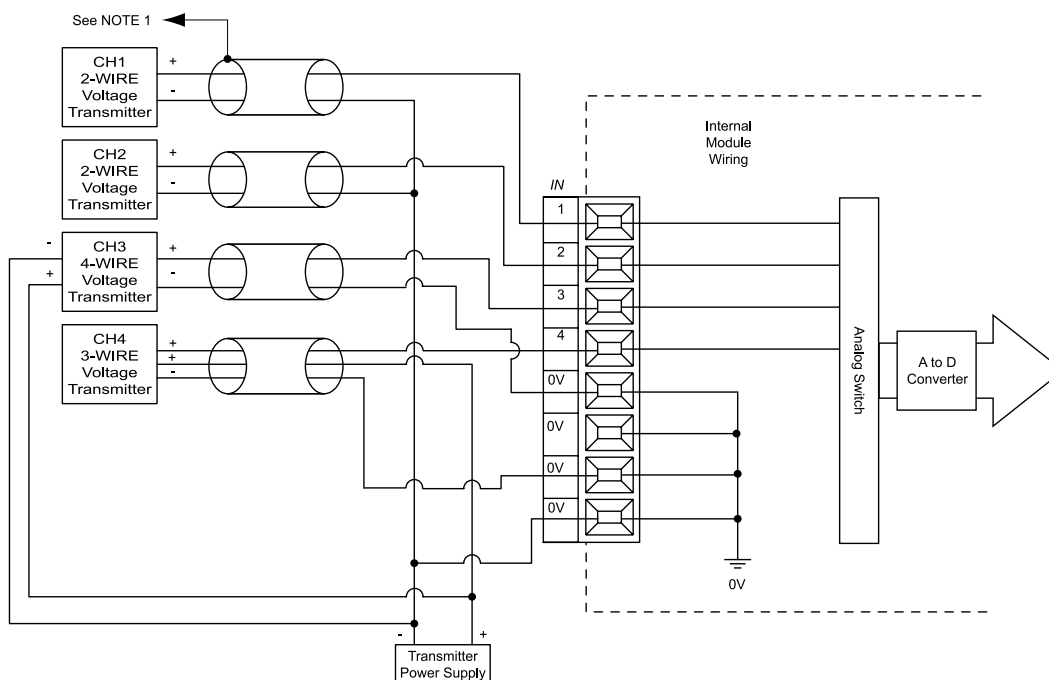

NOTE 1: Ground shields at the signal source.
NOTE 2: Connect all external power supply commons.

DL05/06 Option Modules

F0-08ADH-1 **\$235.00**

8-channel analog current input module, high resolution

Input Specifications	
Number of Channels	8
Input Range	0-20 mA
Resolution	16-bit, 0.305 μ A/bit
Input Type	Single Ended (one common)
Maximum Cont. Overload	\pm 31mA
Input Impedance	100 ohms, 1/10 W, current input
Filter Characteristics	Low pass, -3dB @ 60Hz
PLC Data Format	16-bit, Unsigned Int., 0-FFFF (binary) or 0-65535 (BCD) (Both require 2 words of V-memory)
Sample Duration Time	10.2 ms (time to 95% of full step change / channel)
All Channel Update Rate	81.6 ms
Open Circuit Detection Time	Zero reading within 1s
Conversion Method	Successive Approximation
Accuracy vs. Temperature	\pm 50PPM/ $^{\circ}$ C Max.
Maximum Inaccuracy	0.2% of range (including temp. changes)
Linearity Error (End to End)	\pm 10 count max.; Monotonic with no missing codes
Input Stability and Repeatability	\pm 10 count max.
Full Scale Calibration Error	\pm 10 count max.
Offset Calibration Error	\pm 10 count max.
Maximum Crosstalk at DC, 50 Hz and 60 Hz	\pm 10 count max.
External 24VDC Power Required	25mA
Base Power Required (5.0V)	25mA
Terminal Type (Included)	Removable: D0-ACC-4
Recommended Fuse	Littelfuse Series 217, 0.032 A fuse



See Wiring Solutions for part numbers of ZIPLink cables and connection modules compatible with this I/O module.

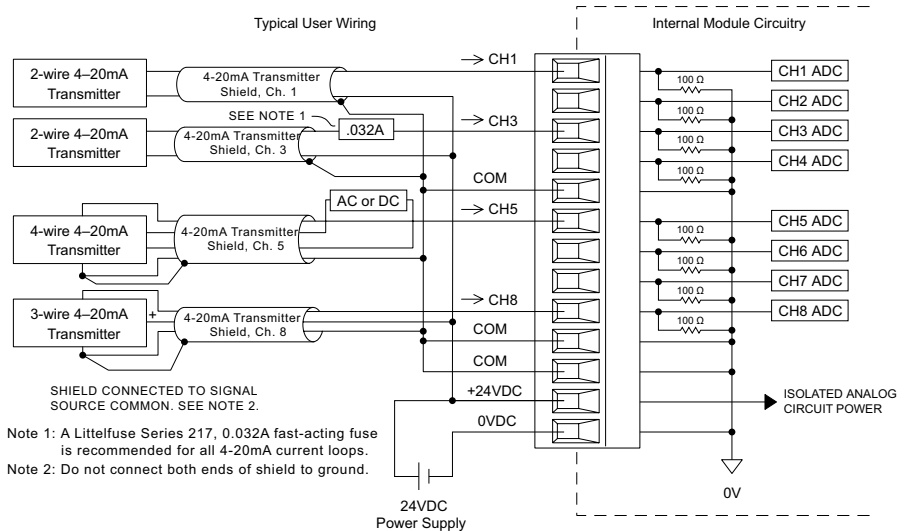
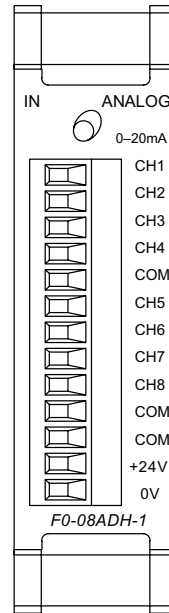

CPU	Firmware Required	DirectSOFT Required
DL05	Version 5.20 or later	DirectSOFT32 Version 3.0c or later
DL06	Version 2.30 or later	DirectSOFT32 Version 4.0, Build 16 or later

DL05/06 I/O Option Modules

F0-08ADH-2 **\$248.00**

8-channel analog voltage input module, high resolution

Input Specifications	
Number of Channels	8
Input Range	0-5 VDC or 0-10 VDC (Jumper select)
Resolution	16-bit, 76µV/bit or 152µV/bit
Input Type	Single Ended (one common)
Maximum Cont. Overload	±100V
Input Impedance	>200kΩ
Filter Characteristics	Low pass, -3dB @ 60Hz
PLC Data Format	16-bit, Unsigned Int., 0-FFFF (binary) or 0-65535 (BCD) (Both require 2 words of V-memory)
Sample Duration Time	10.2 ms
All Channel Update Rate	81.6 ms
Conversion Method	Successive Approximation
Accuracy vs. Temperature	±50PPM / °C Maximum
Maximum Inaccuracy	0.2% of range (including temp. drift)
Linearity Error (End to End)	±10 count max. Monotonic with no missing codes
Input Stability and Repeatability	±10 count (after 10 min. warm up)
Full Scale Calibration Error (including Offset)	±10 counts max.
Offset Calibration Error	±10 count max.
Maximum Crosstalk at DC, 50 Hz and 60 Hz	±10 count max.
External 24VDC Power Required	25mA
Base Power Required (5.0V)	25mA

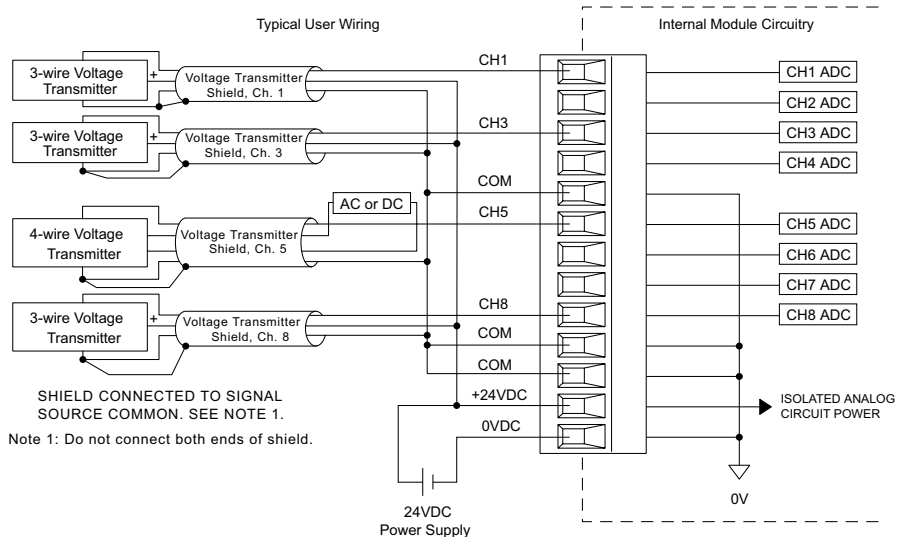
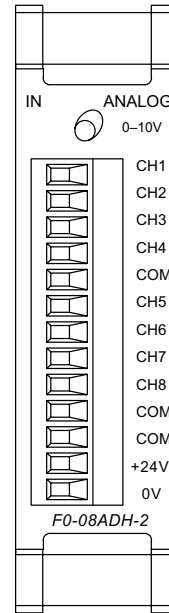

CPU	Firmware Required	DirectSOFT Required
DL05	Version 5.20 or later	DirectSOFT32 Version 3.0c or later
DL06	Version 2.30 or later	DirectSOFT32 Version 4.0, Build 16 or later



See *Wiring Solutions* for part numbers of ZIPLink cables and connection modules compatible with this I/O module.

DL05/06 I/O Option Modules

FO-04THM \$364.00

4-channel thermocouple input module

FO-04THM 4-Channel Thermocouple Input	
General Specifications	
Number of Channels	4, differential
Common Mode Range	-1.3 VDC to +3.8 VDC
Common Mode Rejection	100dB min. @ VDC 50–60 Hz.
Input Impedance	5M Ω
Absolute Maximum Ratings	Fault-protected inputs to \pm 50VDC
Accuracy vs. Temperature (Max. Full Scale Error)	\pm 15ppm/ $^{\circ}$ C maximum 0 - 1.25V \pm 35ppm/ $^{\circ}$ C maximum (Including maximum offset change)
PLC Update Rate	4 channels per scan
Digital Inputs	None; uses special V-memory location based on slot
Base Power Required	30mA @ 5VDC supplied by base
Operating Temperature	32 $^{\circ}$ to 140 $^{\circ}$ F (0 $^{\circ}$ to 60 $^{\circ}$ C)
Storage Temperature	-4 $^{\circ}$ to 158 $^{\circ}$ F (-20 $^{\circ}$ to 70 $^{\circ}$ C)
Relative Humidity	5 to 95% (non-condensing)
Environmental Air	No corrosive gases permitted
Vibration	MIL STD 810C 514.2
Shock	MIL STD 810C 516.2
Noise Immunity	NEMA ICS3-304
Terminal Block Replacement	FO-IOCON-THM (comes with CJC)

Thermocouple Specifications		
Input Ranges	Type J -190 to 760 $^{\circ}$ C	-310 to 1400 $^{\circ}$ F
	Type E -210 to 1000 $^{\circ}$ C	-346 to 1832 $^{\circ}$ F
	Type K -150 to 1372 $^{\circ}$ C	-238 to 2502 $^{\circ}$ F
	Type R 65 to 1768 $^{\circ}$ C	149 to 3214 $^{\circ}$ F
	Type S 65 to 1768 $^{\circ}$ C	149 to 3214 $^{\circ}$ F
	Type T -230 to 400 $^{\circ}$ C	-382 to 752 $^{\circ}$ F
	Type B 529 to 1820 $^{\circ}$ C	984 to 3308 $^{\circ}$ F
	Type N -70 to 1300 $^{\circ}$ C	-94 to 2372 $^{\circ}$ F
	Type C 65 to 2320 $^{\circ}$ C	149 to 4208 $^{\circ}$ F
	Display Resolution	\pm 0.1 $^{\circ}$ C or \pm 0.1 $^{\circ}$ F
Cold Junction Compensation	Automatic	
Conversion Time	270ms per channel	
Warm-Up Time	30 minutes typically \pm 1 $^{\circ}$ C repeatability	
Linearity Error (End to End)	\pm 1 $^{\circ}$ C maximum, \pm 0.5 $^{\circ}$ C typical	
Maximum Inaccuracy	\pm 3 $^{\circ}$ C (excluding thermocouple error)	

CPU	Firmware Required	DirectSOFT Required
DL05	Version 4.60 or later	DirectSOFT32 Version 3.0c or later
DL06	Version 1.40 or later	DirectSOFT32 Version 4.0, Build 16 or later

Voltage Input Specifications	
Voltage Ranges	0-39.0625mV, \pm 39.0625mV, \pm 78.125mV, 0-156.25mV, \pm 156.25mVDC, 0-1.25V
Resolution	16 bit (1 in 65535)
Max. Offset Error (All Input Ranges)	0.05% @ 0-60 $^{\circ}$ C; Typical: 0.04% @ 25 $^{\circ}$ C
Linearity Error (All Input Ranges)	0.05% @ 0-60 $^{\circ}$ C; Typical: 0.03% @ 25 $^{\circ}$ C
Maximum Inaccuracy	0-39.0625mV, \pm 39.0625mV, \pm 78.125mV ranges: 0.1% @ 0-60 $^{\circ}$ C; Typical: 0.04% @ 25 $^{\circ}$ C 0-156.25mV, \pm 156.25mVDC, 0-1.25V ranges: 0.05% @ 0-60 $^{\circ}$ C; Typical: 0.04% @ 25 $^{\circ}$ C

Thermocouple Input wiring diagram

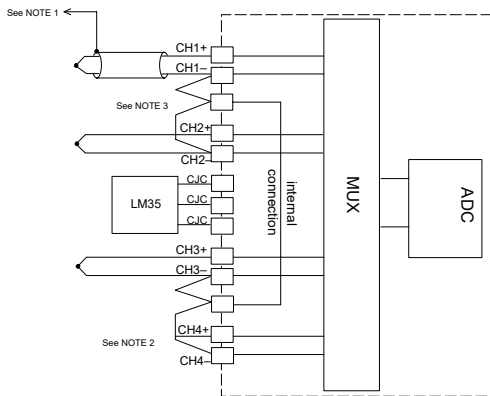

Voltage Input wiring diagram

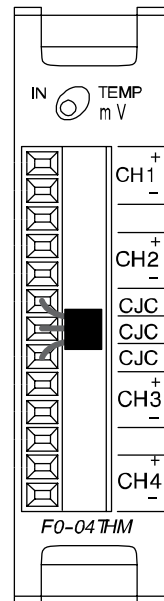
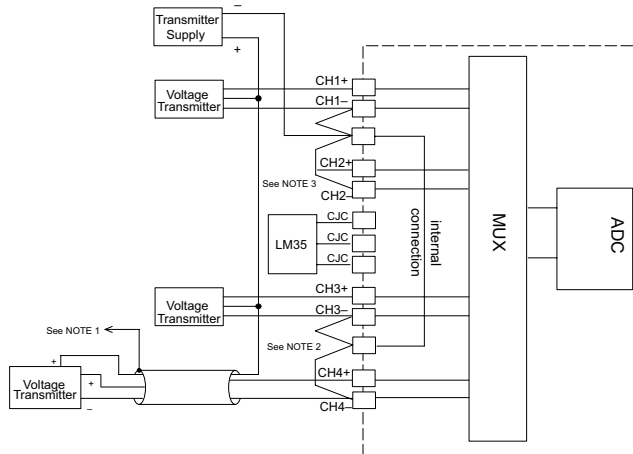

- Notes:
1. Shields should be grounded at the PLC power source only.
 2. Unused channels should have a shorting wire (jumper) installed from CH+ to CH-.
 3. All CH- terminals must be connected together.
 4. This module is not compatible with the ZIPLink wiring system.

DL05/06 Option Modules

F0-04RTD \$345.00

4-channel RTD input module

F0-04RTD Input Specifications	
Number of Channels	4
Input Ranges	Type Pt100: -200.0/850.0°C, -328/1562°F Type Pt1000: -200.0/595.0°C, -328/1103°F Type jPt100: -38.0/450.0°C, -36/842°F Type CU-10/25: -200.0/260.0°C, -328/500°F Type NI-120: -80.0/260.0°C, -112/500°F
Resolution	16 bit (1 in 65535)
Display Resolution	±0.1°C, ±0.1°F (±3276.7)
RTD Excitation Current	200µA
Notch Filter	> 50 db notches at 50/60 Hz
Maximum Setting Time	100ms (full-scale step input)
Common Mode Range	0-5 VDC
Absolute Maximum Ratings	Fault protected inputs to ±50VDC
Sampling Rate	140ms per channel

F0-04RTD Input Specifications (cont'd)	
Terminal Type (included)	Removable: D0-ACC-4
Converter Type	Charge Balancing
Linearity Error	±.05°C maximum, ±.01°C typical
Maximum Inaccuracy	±1°C
PLC Update Rate	4 channel/scan
Digital Input Points Required	None; uses special V-memory location based on slot
Base Power Required 5VDC	70mA
Operating Temperature	32° to 140°F (0° to 60°C)
Storage Temperature	-4° to 158°F (-20° to 70°C)
Temperature Drift	15ppm / °C max
Relative Humidity	5 to 95% (non-condensing)
Environmental Air	No corrosive gases permitted
Vibration	MIL STD 810C 514.2
Shock	MIL STD 810C 516.2
Noise Immunity	NEMA ICS3-304

CPU	Firmware Required	DirectSOFT Required
DL05	Version 4.70 or later	DirectSOFT32 Version 3.0c or later
DL06	Version 1.50 or later	DirectSOFT32 Version 4.0, Build 16 or later

Notes:

1. The three wires connecting the RTD to the module must be the same type and length. Do not use the shield or drain wire for the third connection.
2. Unused channels require shorting wires (jumpers) installed from terminals CH+ to CH- to COM to prevent possible noise from influencing active channels. This should be done even if the unused channel is not enabled in the V-memory configuration.
3. If an RTD sensor has four wires, the plus sense wire should be left unconnected as shown.
4. This module is not compatible with the ZIPLink wiring system.

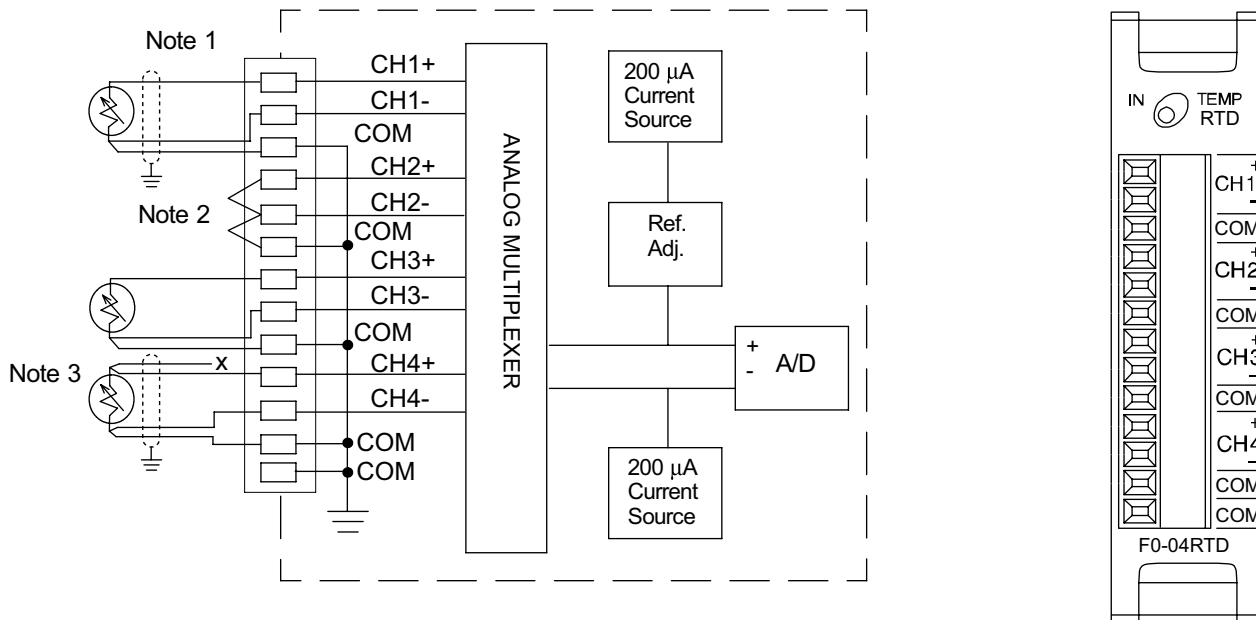

DL05/06 Option Modules

F0-04DAH-1 **\$251.00**

4-channel analog current output module, high resolution

Output Specifications	
Number of Channels	4
Output Range	4-20 mA
Resolution	16-bit, .244µA/bit
Output Type	Current sourcing at 20mA max.
PLC Data Format	16-bit, Unsigned Int., 0-FFFF (binary) or 0-65535 (BCD) (Both require 2 words of V-memory)
Output value in program mode	4mA
Load Impedance	250-750 Ohms
Maximum Inductive Load	1mH
Allowed load type	Grounded
Maximum Inaccuracy	0.2% of range
Maximum Full Scale Calibration Error (not including offset error)	±0.025% of range max.
Maximum Offset Calibration Error	±0.025% of range max.
Accuracy vs. Temperature	±50 ppm/ °C max. full scale calibration change
Maximum Crosstalk	±10 counts
Linearity Error (End to End)	±16 count maximum (±0.025% of full scale) Monotonic with no missing codes
Output Stability and Repeatability	±10 LSB after 10 min. warm-up typical
Output Ripple	0.05% of Full Scale
Output Settling Time	0.5 ms max., 5 µs min. (full scale change)
All Channel Update Rate	100µs
Maximum Continuous Overload	Outputs open circuit protected
Type of Output Protection	Electronically current limited to 20mA or less
Output signal at power-up and power-down	4mA
Terminal Type (Included)	Removable: D0-ACC-4
External 24VDC Power Required	150mA
Base Power Required (5.0V)	25mA

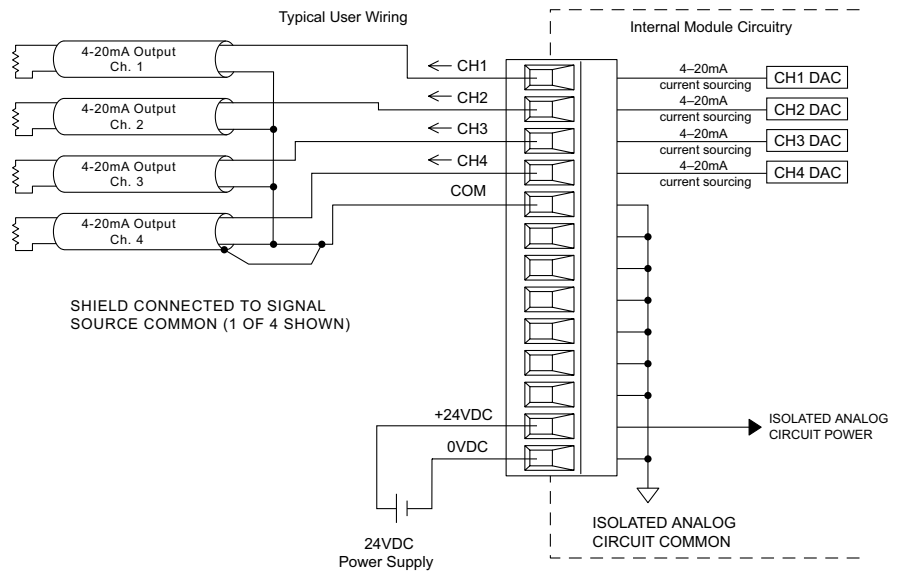
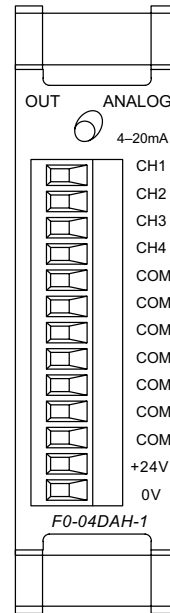

CPU	Firmware Required	DirectSOFT Required
DL05	Version 5.20 or later	DirectSOFT32 Version 3.0c or later
DL06	Version 2.30 or later	DirectSOFT32 Version 4.0, Build 16 or later



See *Wiring Solutions* for part numbers of ZIPLink cables and connection modules compatible with this I/O module.

DL05/06 I/O Option Modules

F0-08DAH-1 \$330.00

8-channel analog current output module, high resolution

Output Specifications	
Number of Channels	8
Output Range	4-20 mA
Resolution	16-bit, 0.244 μ A/bit
Output Type	Current sourcing at 20mA max.
PLC Data Format	16-bit, Unsigned Int., 0-FFFF (binary) or 0-65535 (BCD) (Both require 2 words of V-memory)
Output value in program mode	4mA
Load Impedance	250-750 Ohms
Maximum Inductive Load	1mH
Allowed load type	Grounded
Maximum Inaccuracy	0.2% of range
Maximum Full Scale Calibration Error (not including offset error)	$\pm 0.025\%$ of range maximum
Maximum Offset Calibration Error	$\pm 0.025\%$ of range maximum
Accuracy vs. Temperature	± 50 ppm/ $^{\circ}$ C maximum full scale calibration change
Maximum Crosstalk	± 10 counts
Linearity Error (End to End)	± 16 count maximum ($\pm 0.025\%$ of full scale) Monotonic with no missing codes
Output Stability and Repeatability	± 10 counts after 10 min. warm-up typical
Output Ripple	0.05% of Full Scale
Output Settling Time	0.5 ms max., 5 μ s min. (full scale change)
All Channel Update Rate	100 μ s
Maximum Continuous Overload	Outputs open circuit protected
Type of Output Protection	Electronically current limited to 20mA or less
Output signal at power-up and power-down	4mA
Terminal Type (Included)	Removable: D0-ACC-4
External 24VDC Power Required	220mA
Base Power Required (5.0V)	25mA

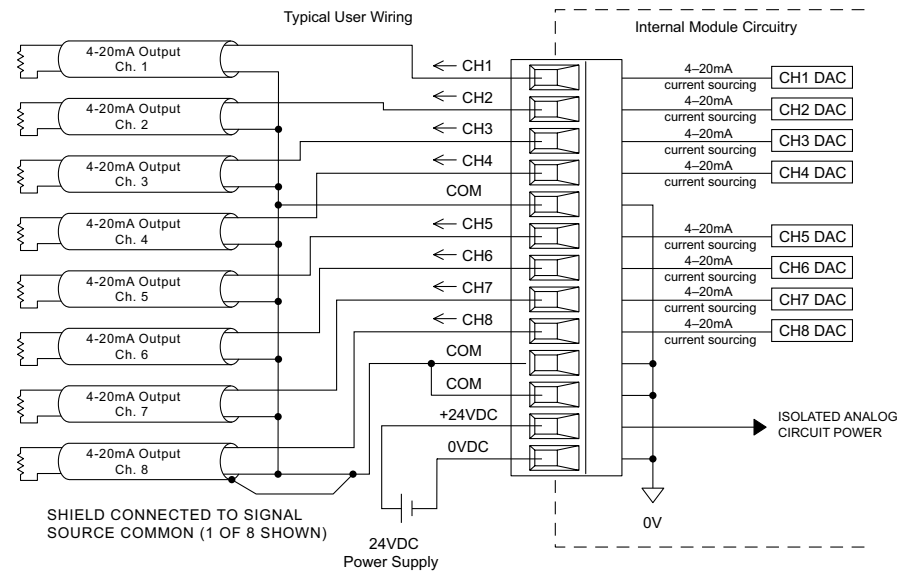
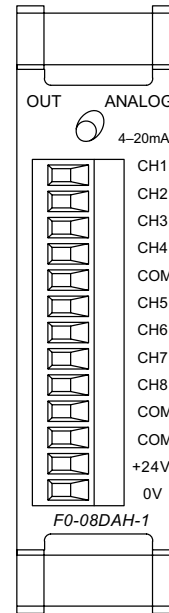

CPU	Firmware Required	DirectSOFT Required
DL05	Version 5.20 or later	DirectSOFT32 Version 3.0c or later
DL06	Version 2.30 or later	DirectSOFT32 Version 4.0, Build 16 or later



See Wiring Solutions for part numbers of ZIPLink cables and connection modules compatible with this I/O module.

DL05/06 Option Modules

F0-04DAH-2 **\$236.00**

4-channel analog voltage output module, high resolution

Output Specifications	
Number of Channels	4
Output Range	0-10 VDC
Resolution	16-bit, 152µV/bit
Output Type	Voltage sourcing/sinking at 5mA max.
PLC Data Format	16-bit, Unsigned Int., 0-FFFF (binary) or 0-65535 (BCD) (Both require 2 words of V-memory)
Output value in program mode	0V
Output Impedance	0.5 Ohms typical
Load Impedance	>2000Ω
Maximum Capacitive Load	0.01 µF maximum
Allowed load type	Grounded
Maximum Inaccuracy	0.2% of range (including temperature changes)
Maximum Full Scale Calibration Error (including offset error)	±.025% of range max.
Maximum Offset Calibration Error	±.025% of range max.
Accuracy vs. Temperature	±50 ppm/ °C max. full scale calibration change
Maximum Crosstalk	±10 counts
Linearity Error (End to End)	±16 count max. (±0.025% of full scale) Monotonic with no missing codes
Output Stability and Repeatability	±10 counts after 10 min. warm-up typical
Output Ripple	0.05% of Full Scale
Output Settling Time	0.05 ms max., 5µs min. (full scale change)
All Channel Update Rate	100µs
Maximum Continuous Overload	Outputs current limited to 40mA typical. A continuous short circuit will damage the output.
Type of Output Protection	24VDC Peak Output Voltage (capacitor transient voltage suppressor)
Output signal at power-up and power-down	0V
Terminal Type (Included)	Removable: D0-ACC-4
External 24VDC Power Required	30mA
Base Power Required (5.0V)	25mA

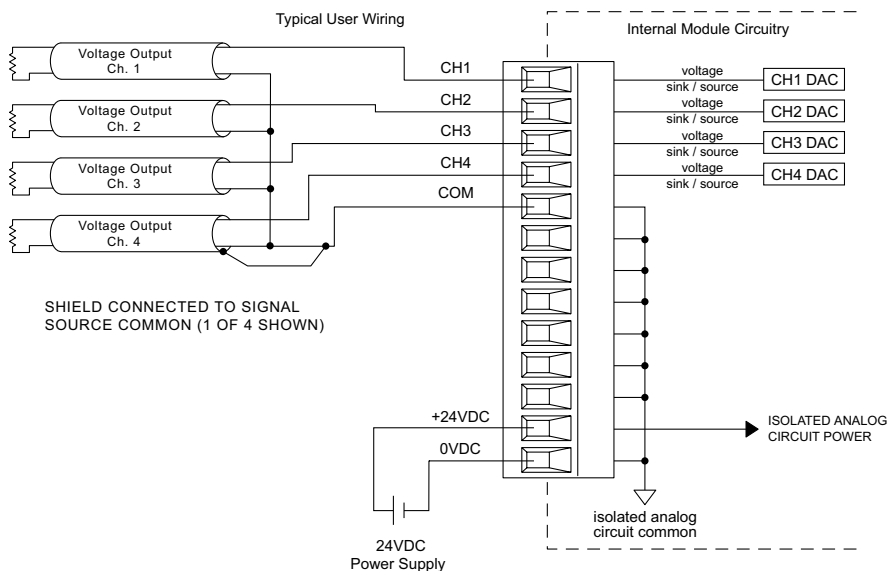
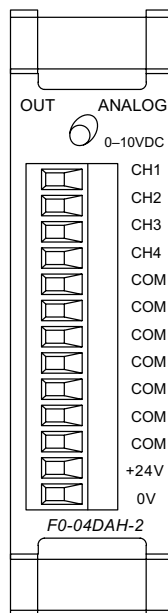

See **Wiring Solutions** for part numbers of **ZIPLink** cables and connection modules compatible with this I/O module.

CPU	Firmware Required	DirectSOFT Required
DL05	Version 5.20 or later	DirectSOFT32 Version 3.0c or later
DL06	Version 2.30 or later	DirectSOFT32 Version 4.0, Build 16 or later

DL05/06 I/O Option Modules

F0-08DAH-2 **\$314.00**

8-channel analog voltage output module, high resolution

Output Specifications	
Number of Channels	8
Output Range	0-10 VDC
Resolution	16-bit, 152µV/bit
Output Type	Voltage sourcing/sinking at 5mA max.
PLC Data Format	16-bit, Unsigned Int., 0-FFFF (binary) or 0-65535 (BCD) (Both require 2 words of V-memory)
Output value in program mode	0V
Output Impedance	0.5 Ohms typical
Load Impedance	>2000Ω
Maximum Capacitive Load	0.01 µF maximum
Allowed load type	Grounded
Maximum Inaccuracy	0.2% of range (including temperature changes)
Maximum Full Scale Calibration Error (including offset error)	±0.25% of range maximum
Maximum Offset Calibration Error	±0.25% of range maximum
Accuracy vs. Temperature	±50 ppm/ °C maximum full scale calibration change
Maximum Crosstalk	10 counts
Linearity Error (End to End)	±16 count maximum (±0.025% of full scale) Monotonic with no missing codes
Output Stability and Repeatability	±10 counts after 10 min. warm-up typical
Output Ripple	0.05% of Full Scale
Output Settling Time	0.5 ms max., 5µs min. (full scale change)
All Channel Update Rate	100µs
Maximum Continuous Overload	Outputs current limited to 40mA typical. A continuous short circuit will damage the output.
Type of Output Protection	24VDC Peak Output Voltage (capacitor transient voltage suppressor)
Output signal at power-up and power-down	0V
Terminal Type (Included)	Removable: D0-ACC-4
External 24VDC Power Required	30mA
Base Power Required (5.0V)	25mA

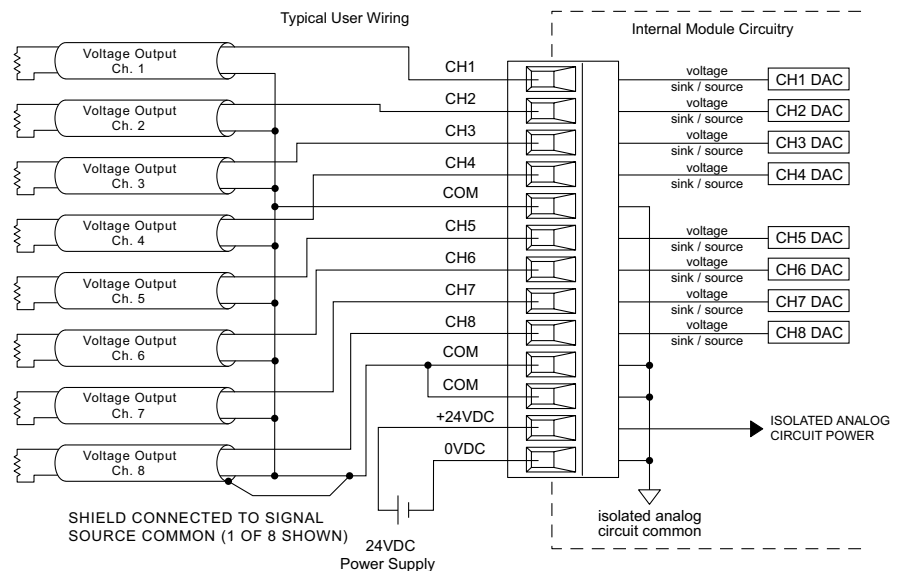
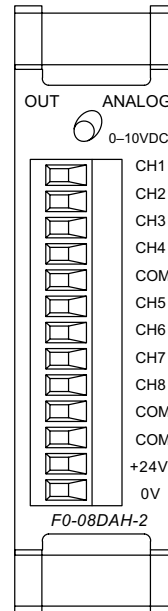

See Wiring Solutions for part numbers of ZIPLink cables and connection modules compatible with this I/O module.

CPU	Firmware Required	DirectSOFT Required
DL05	Version 5.20 or later	DirectSOFT32 Version 3.0c or later
DL06	Version 2.30 or later	DirectSOFT32 Version 4.0, Build 16 or later

DL05/06 Option Modules

F0-2AD2DA-2 \$264.00

2-channel analog voltage input and
2-channel analog voltage output module

F0-2AD2DA-2 Input Specifications	
Number of Channels	2, single ended (one common)
Input Range	0 to 5 VDC or 0 to 10 VDC (jumper selectable)
Resolution	12-bit (1 in 4096)
Step Response	10.0 ms to 95% of full step change
Crosstalk	1/2 count max (-80db)*
Active Low-pass Filtering	-3dB at 300Hz (-12dB per octave)
Input Impedance	>20kΩ
Absolute Max Ratings	±15V
Linearity Error (end to end)	±2 counts (0.025% of full scale) max*
Input Stability	±1 count*
Gain Error	±6 counts max*
Offset Error	±2 counts max*
Max Inaccuracy	±0.3% at 25-C (77-F)
	±0.6% at 0 to 60--C (32 to 140-F)
Accuracy vs. Temperature	±100 ppm/-C typical

F0-2AD2DA-2 Output Specifications	
Number of Channels	2, single ended (one common)
Output Range	0 to 5 VDC or 0 to 10 VDC (jumper selectable)
Resolution	12-bit (1 in 4096)
Conversion Settling Time	50µs for full scale change
Crosstalk	1/2 count max (-80db)*
Peak Output Voltage	±supply limited)
Offset Error	0.1% of range
Gain Error	0.4% of range
Linearity Error (end to end)	±1 counts (0.075% of full scale) max*
Output Stability	±2 counts*
Load Impedance	2kΩ min
Load Capacitance	0.01 µF max
Terminal Type (Included)	Removable: F0-IOCON
Accuracy vs. Temperature	±50ppm /°C typical

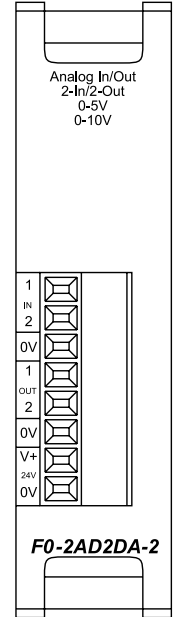

* One count in the specification table is equal to one least significant bit of the analog data value (1 in 4096)



See Wiring Solutions for part numbers of ZIPLink cables and connection modules compatible with this I/O module.

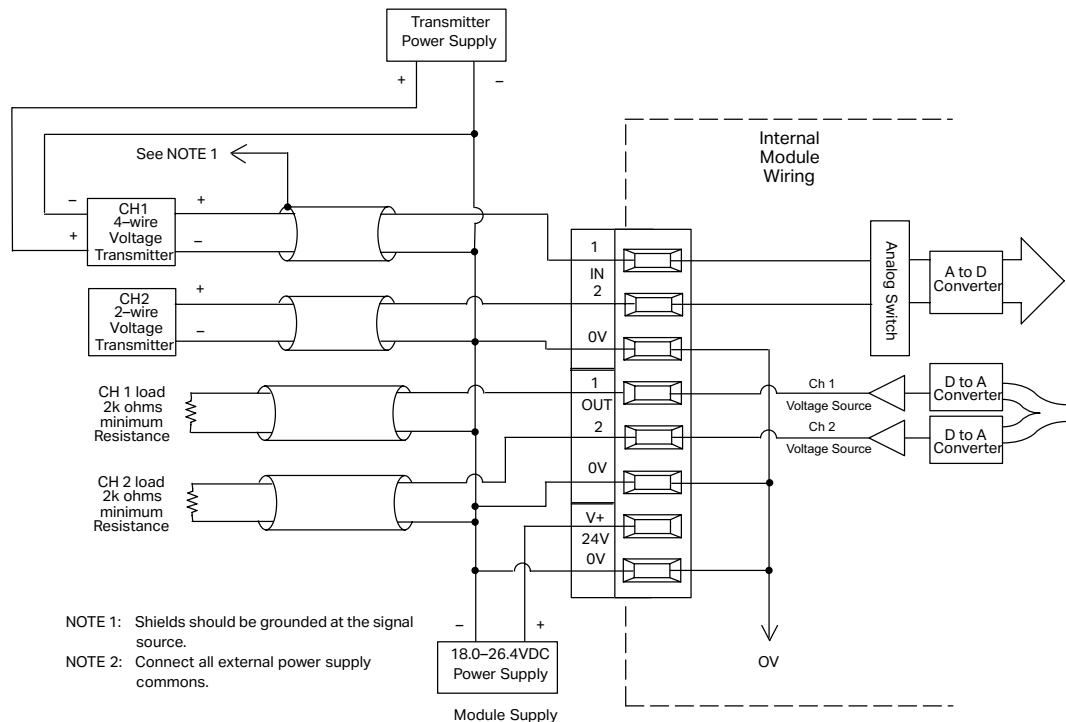

DL05/06 Option Modules

F0-4AD2DA-1 \$336.00

4-channel analog current input and 2-channel analog current output module

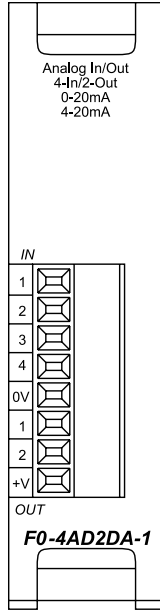

F0-4AD2DA-1 Input Specifications	
Number of Channels	4, single ended (one common)
Input Range	0 to 20 mA or 4 to 20 mA (jumper selectable)
Resolution	12 bit (1 in 4096)
Step Response	25.0 ms (typ.) to 95% of full step change
Crosstalk	1/2 count max (-80db)*
Active Low-pass Filtering	-3 dB at 40 Hz (-12dB per octave)
Input Impedance	125h ±0.1%, 1/8 watt
Absolute Max Ratings	-30mA to +30mA, current input
Converter Type	Successive approximation
Linearity Error (end to end)	±2 counts
Input Stability	±1 count*
Full-scale Calibr. Error	±10 counts max. @ 20mA*
Offset Calibration Error	±5 counts max. @ 0 mA*
Max Inaccuracy	±0.4% at 25-C (77°F) ±0.85% at 0 to 60°C (32 to 140°F)
Accuracy vs. Temp.	±100 ppm/°C typ.
Recommended Fuse	0.032 A, series 217 fast-acting, current inputs

F0-4AD2DA-1 Output Specifications	
Number of Channels	2, single ended (one common)
Output Range	0 to 20 mA or 4 to 20 mA (jumper selectable)
Output Type	Current sourcing
Resolution	12-bit (1 in 4096)
Max. Loop Voltage	30VDC
Load/loop Power Supply	0-300 Ω / 18-30 VDC
Linearity Error (end to end)	±2 counts (0.050% of full scale) max.*
Conversion Settling Time	400µs max. for full scale change
Full-scale Calibration Error	±26 counts max. @ 300 Ω load ±18 counts max. @ 250 Ω load ±12 counts max. @ 125 Ω load
Offset Calibration Error	±10 counts max. @ 300 Ω load ±8 counts max. @ 250 Ω load ±6 counts max. @ 125 Ω load
Terminal Type (Included)	Removable: F0-IOCON
Max.Full-scale Inaccuracy (all errors included)	300 Ω load 0.4%. @ 60°C 250 Ω load 0.3%. @ 60°C 125 Ω load 0.2%. @ 60°C

* One count in the specification table is equal to one least significant bit of the analog data value (1 in 4096)



See Wiring Solutions for part numbers of ZIPLink cables and connection modules compatible with this I/O module.

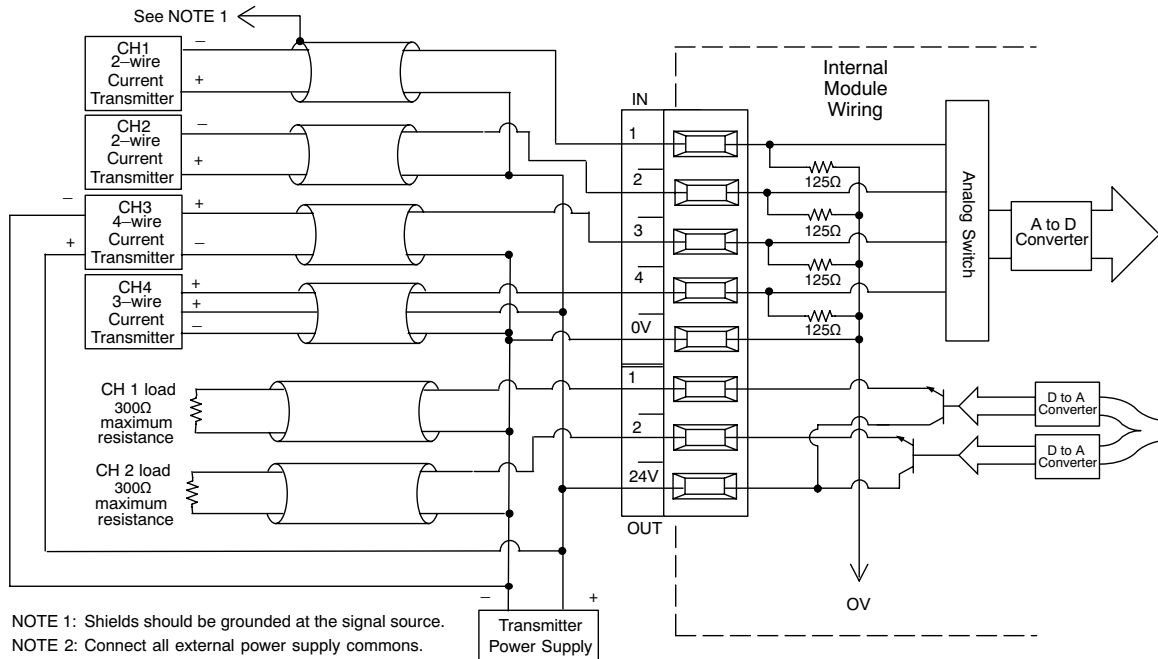

NOTE 1: Shields should be grounded at the signal source.
NOTE 2: Connect all external power supply commons.

DL05/06 Option Modules

F0-4AD2DA-2 \$372.00

4-channel analog voltage input
2-channel analog voltage output module

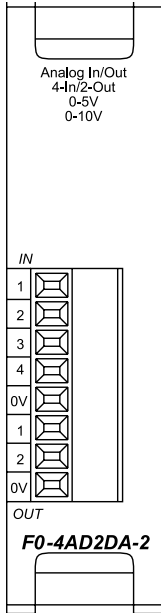

F0-4AD2DA-2 Input Specifications	
Number of Channels	4, single ended (one common)
Input Range	0 to 5 VDC or 0 to 10 VDC (jumper selectable)
Resolution	12-bit (1 in 4096)
Step Response	10.0 ms to 95% of full step change
Crosstalk	1/2 count max (-80db)*
Active Low-pass Filtering	-3dB at 300Hz (-12dB per octave)
Input Impedance	>20kΩ
Absolute Max Ratings	±15V
Linearity Error (end to end)	±2 count (0.025% of full scale) max*
Input Stability	±1 count*
Gain Error	±6 counts max*
Offset Error	±2 counts max*
Max Inaccuracy	±0.3% at 25°C (77°F)
	±0.6% at 0 to 60°C (32 to 140°F)
Accuracy vs. Temperature	±100 ppm/°C typical
Terminal Type (Included)	Removable: F0-IOCON

F0-4AD2DA-2 Output Specifications	
Number of Channels	2, single ended (one common)
Output Range	0 to 5 VDC or 0 to 10 VDC (jumper selectable)
Resolution	12-bit (1 in 4096)
Conversion Settling Time	50µs for full scale change
Crosstalk	1/2 count max (-80db)*
Peak Output Voltage	±15VDC (power supply limited)
Offset Error	0.1% of range
Gain Error	0.4% of range
Linearity Error (end to end)	±1 counts (0.075% of full scale) max*
Output Stability	±2 counts*
Load Impedance	2kΩ minimum
Load Capacitance	0.01 µF max
Accuracy vs. Temperature	±50 ppm/°C typical

* One count in the specification table is equal to one least significant bit of the analog data value (1 in 4096)



See *Wiring Solutions* for part numbers of ZIPLINK cables and connection modules compatible with this I/O module.

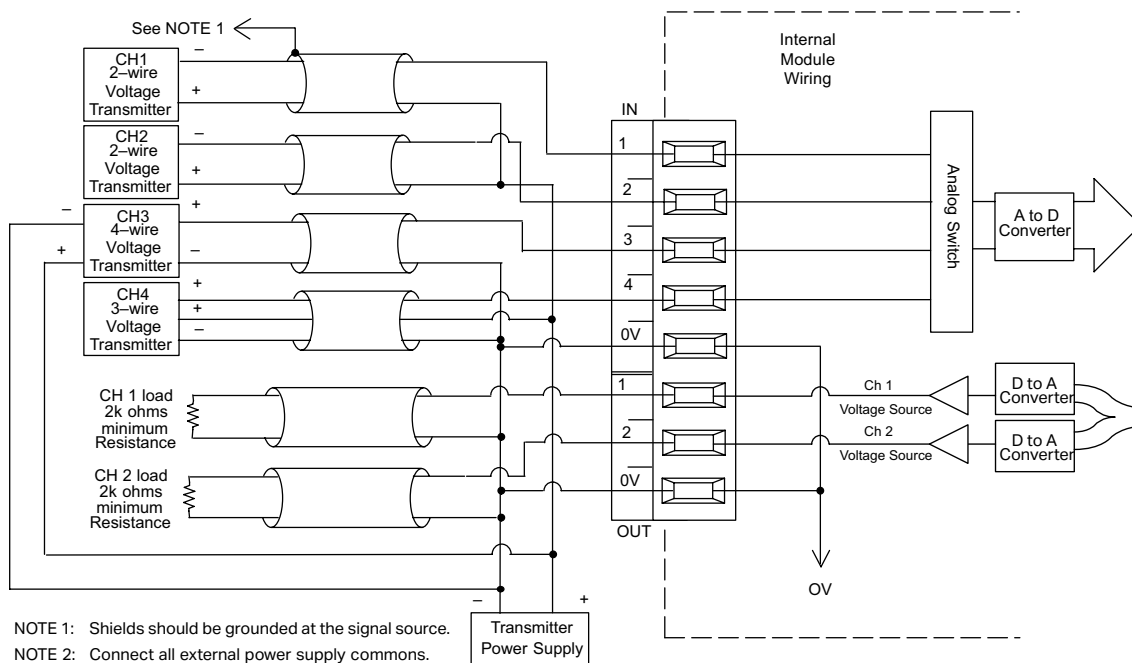

Power Budgeting for the DL06

The DL06 has four option module slots. To determine whether the combination of modules you select will have sufficient power, you will need to perform a power budget calculation.

Power supplied

Power is supplied from two sources: the internal base unit power supply and, if required, an external supply (customer furnished). The D0-06xx (AC powered) PLCs supply a limited amount of 24VDC power. The 24VDC output can be used to power external devices.

For power budgeting, start by considering the power supplied by the base unit. All DL06 PLCs supply the same amount of 5VDC power. Only the AC units offer 24VDC auxiliary power.

Be aware of the trade-off between 5VDC power and 24VDC power. The amount of 5 VDC power available depends on the amount of 24VDC power being used, and the amount of 24VDC power available depends on the amount of 5VDC power consumed. Determine the amount of internally supplied power from the table to the right.

Power required by base unit

Because of the different I/O configurations available in the DL06 family, the power consumed by the base unit itself varies from model to model. Subtract the amount of power required by the base unit from the amount of power supplied by the base unit. Be sure to subtract 5VDC and 24VDC amounts.

Power required by option modules

Next, subtract the amount of power required by the option modules you are planning to use. Again, remember to subtract both 5VDC and 24VDC.

If your power budget analysis shows surplus power available, you should have a workable configuration.

DL06 Power Supplied by Base Units		
Part Number	5 VDC (mA)	24 VDC (mA)
D0-06xx	1500mA	300mA
	2000mA	200mA
D0-06xx-D	1500mA	none

DL06 Base Unit Power Required		
Part Number	5 VDC (mA)	24 VDC (mA)
D0-06AA	800mA	none
D0-06AR	900mA	none
D0-06DA	800mA	none
D0-06DD1	600mA	280mA*
D0-06DD2	600mA	none
D0-06DR	950mA	none
D0-06DD1-D	600mA	none
D0-06DD2-D	600mA	none
D0-06DR-D	950mA	none

* Only if auxiliary 24VDC power is connected to V+ terminal.

DL06 Power Consumed by Other Devices		
Part Number	5 VDC (mA)	24 VDC (mA)
D0-06LCD	50mA	none
D2-HPP	200mA	none
DV-1000	150mA	none
C-more Micro-Graphic	210mA	none

Power Budgeting Example			
Power Source		5VDC power (mA)	24VDC power (mA)
D0-06DD1 (select row A or B)	A	1500mA	300mA
	B	2000mA	200mA
Current Required		5VDC power (mA)	24VDC power (mA)
D0-06DD1		600mA	280mA*
D0-16ND3		35mA	0
D0-10TD1		150mA	0
D0-08TR		280mA	0
F0-4AD2DA-1		100mA	0
D0-06LCD		50mA	0
Total Used		1215mA	280mA
Remaining	A	285mA	20mA
	B	785mA	note 1

* Auxiliary 24 VDC used to power V+ terminal of D0-06DD1 sinking outputs.

Note 1: If the PLC's auxiliary 24 VDC power source is used to power the sinking outputs, use power choice A, above.

DL05/06 Power Consumed by Option Modules		
Part Number	5 VDC (mA)	24 VDC (mA)
D0-07CDR	130mA	none
D0-08CDD1	100mA	none
D0-08TR	280mA	none
D0-10ND3	35mA	none
D0-10ND3F	35mA	none
D0-10TD1	150mA	none
D0-10TD2	150mA	none
D0-16ND3	35mA	none
D0-16TD1	200mA	none
D0-16TD2	200mA	none
F0-04TRS	250mA	none
F0-08NA-1	5mA	none
F0-04AD-1	50mA	none
F0-04AD-2	75mA	none
F0-08ADH-1	25mA	25mA
F0-08ADH-2	25mA	25mA
F0-04DAH-1	25mA	150mA
F0-08DAH-1	25mA	220mA
F0-04DAH-2	25mA	30mA
F0-08DAH-2	25mA	30mA
F0-2AD2DA-2	50mA	30mA
F0-4AD2DA-1	100mA	40mA
F0-4AD2DA-2	100mA	none
F0-04RTD	70mA	none
F0-04THM	30mA	none
D0-DEVNETS	45mA	none
H0-CTRIO2	250mA	none
H0-ECOM100	300mA	none
F0-08SIM	1mA	none
D0-DCM	250 mA	none
F0-CP128	150 mA	none
F0-08SIM	1 mA	none